

# 16 Megabit (1M x 16-Bit) Multi-Purpose Flash

## SST39VF160Q / SST39VF160



Advance Information

### FEATURES:

- **Organized as 1 M X 16**
- **Single 2.7V-only Read and Write Operations**
- **V<sub>DDQ</sub> Power Supply to Support 5V I/O for SST39VF160Q**
  - V<sub>DDQ</sub> not available on SST39VF160
- **Superior Reliability**
  - Endurance: 100,000 Cycles (typical)
  - Greater than 100 years Data Retention
- **Low Power Consumption:**
  - Active Current: 15 mA (typical)
  - Standby Current: 3  $\mu$ A (typical)
  - Auto Low Power Mode: 3  $\mu$ A (typical)
- **Small Sector Erase Capability (512 sectors)**
  - Uniform 2 KWord sectors
- **Block Erase Capability (32 blocks)**
  - Uniform 32 KWord blocks
- **Fast Read Access Time:**
  - 70 and 90 ns
- **Latched Address and Data**
- **Fast Sector Erase and Word Program:**
  - Sector Erase Time: 3 ms typical
  - Block Erase Time: 7 ms typical
  - Chip Erase Time: 15 ms typical
  - Word Program time: 7  $\mu$ s typical
  - Chip Rewrite Time: 7 seconds
- **Automatic Write Timing**
  - Internal V<sub>pp</sub> Generation
- **End of Write Detection**
  - Toggle Bit
  - Data# Polling
- **CMOS I/O Compatibility**
- **JEDEC Standard**
  - EEPROM Pinouts and command set
- **Packages Available**
  - 48-Pin TSOP (12mm x 20mm)
  - 6 x 8 Ball TFBGA

### PRODUCT DESCRIPTION

The SST39VF160Q/VF160 devices are 1M x 16 CMOS Multi-Purpose Flash (MPF) manufactured with SST's proprietary, high performance CMOS SuperFlash technology. The split-gate cell design and thick oxide tunneling injector attain better reliability and manufacturability compared with alternate approaches. The SST39VF160Q/VF160 write (Program or Erase) with a 2.7V-only power supply. The SST39VF160Q/VF160 conform to JEDEC standard pinouts for x16 memories.

Featuring high performance word program, the SST39VF160Q/VF160 devices provide a maximum word-program time of 10  $\mu$ sec. The entire memory can typically be erased and programmed word by word in 7 seconds, when using interface features such as Toggle Bit or Data# Polling to indicate the completion of Program operation. To protect against inadvertent write, the SST39VF160Q/VF160 have on-chip hardware and software data protection schemes. Designed, manufactured, and tested for a wide spectrum of applications, the SST39VF160Q/VF160 are offered with a guaranteed endurance of 10,000 cycles. Data retention is rated at greater than 100 years.

The SST39VF160Q/VF160 devices are suited for applications that require convenient and economical updating of program, configuration, or data memory. For all system applications, the SST39VF160Q/VF160 significantly improve performance and reliability, while lowering power consumption. The SST39VF160Q/VF160 inherently use less energy during Erase and Program than

alternative flash technologies. The total energy consumed is a function of the applied voltage, current, and time of application. Since for any given voltage range, the SuperFlash technology uses less current to program and has a shorter erase time, the total energy consumed during any Erase or Program operation is less than alternative flash technologies. The SST39VF160Q/VF160 also improve flexibility while lowering the cost for program, data, and configuration storage applications.

The SuperFlash technology provides fixed Erase and Program times, independent of the number of endurance cycles that have occurred. Therefore the system software or hardware does not have to be modified or de-rated as is necessary with alternative flash technologies, whose erase and program times increase with accumulated endurance cycles.

To meet high density, surface mount requirements, the SST39VF160Q/VF160 are offered in 48-pin TSOP and 48-pin TFBGA packages. See Figures 1 and 2 for pinouts.

### Device Operation

Commands are used to initiate the memory operation functions of the device. Commands are written to the device using standard microprocessor write sequences. A command is written by asserting WE# low while keeping CE# low. The address bus is latched on the falling edge of WE# or CE#, whichever occurs last. The data bus is latched on the rising edge of WE# or CE#, whichever occurs first.



The SST39VF160Q/VF160 also have the **Auto Low Power** mode which puts the device in a near standby mode after data has been accessed with a valid read operation. This reduces the  $I_{DD}$  active read current from typically 15 mA to typically 3  $\mu$ A. The Auto Low Power mode reduces the typical  $I_{DD}$  active read current to the range of 1 mA/MHz of read cycle time. The device exits the Auto Low Power mode with any address transition or control signal transition used to initiate another read cycle, with no access time penalty.

## Read

The Read operation of the SST39VF160Q/VF160 is controlled by CE# and OE#, both have to be low for the system to obtain data from the outputs. CE# is used for device selection. When CE# is high, the chip is deselected and only standby power is consumed. OE# is the output control and is used to gate data from the output pins. The data bus is in high impedance state when either CE# or OE# is high. Refer to the Read cycle timing diagram for further details (Figure 3).

## Word Program Operation

The SST39VF160Q/VF160 are programmed on a word-by-word basis. The Program operation consists of three steps. The first step is the three-byte-load sequence for Software Data Protection. The second step is to load word address and word data. During the word Program operation, the addresses are latched on the falling edge of either CE# or WE#, whichever occurs last. The data is latched on the rising edge of either CE# or WE#, whichever occurs first. The third step is the internal Program operation which is initiated after the rising edge of the fourth WE# or CE#, whichever occurs first. The Program operation, once initiated, will be completed within 10  $\mu$ s. See Figures 4 and 5 for WE# and CE# controlled Program operation timing diagrams and Figure 15 for flowcharts. During the Program operation, the only valid reads are Data# Polling and Toggle Bit. During the internal Program operation, the host is free to perform additional tasks. Any commands issued during the internal Program operation are ignored.

## Sector/Block Erase Operation

The Sector/Block Erase operation allows the system to erase the device on a sector-by-sector (or block-by-block) basis. The SST39VF160Q/VF160 offer both small Sector Erase and Block Erase mode. The sector architecture is based on uniform sector size of 2 KWord. The Block Erase mode is based on uniform block size of 32 KWord. The Sector Erase operation is initiated by executing a six-byte-command sequence with Sector Erase command (30H) and sector address (SA) in the last bus cycle. The address lines A11-A19 are used to determine the sector address. The Block Erase operation is initiated by executing a six-

byte-command sequence with Block Erase command (50H) and block address (BA) in the last bus cycle. The address lines A15-A19 are used to determine the block address. The sector or block address is latched on the falling edge of the sixth WE# pulse, while the command (30H or 50H) is latched on the rising edge of the sixth WE# pulse. The internal Erase operation begins after the sixth WE# pulse. The end of Erase operation can be determined using either Data# Polling or Toggle Bit methods. See Figures 8 and 9 for timing waveforms. Any commands issued during the Sector or Block Erase operation are ignored.

## Chip-Erase Operation

The SST39VF160Q/VF160 provide a Chip Erase operation, which allows the user to erase the entire memory array to the "1" state. This is useful when the entire device must be quickly erased.

The Chip Erase operation is initiated by executing a six byte command sequence with Chip Erase command (10H) at address 5555H in the last byte sequence. The Erase operation begins with the rising edge of the sixth WE# or CE#, whichever occurs first. During the Erase operation, the only valid read is Toggle Bit or Data# Polling. See Table 4 for the command sequence, Figure 8 for timing diagram, and Figure 19 for the flowchart. Any commands issued during the chip erase operation are ignored.

## Write Operation Status Detection

The SST39VF160Q/VF160 provide two software means to detect the completion of a Write (Program or Erase) cycle, in order to optimize the system write cycle time. The software detection includes two status bits: Data# Polling (DQ<sub>7</sub>) and Toggle Bit (DQ<sub>6</sub>). The end of write detection mode is enabled after the rising edge of WE#, which initiates the internal program or erase operation.

The actual completion of the nonvolatile write is asynchronous with the system; therefore, either a Data# Polling or Toggle Bit read may be simultaneous with the completion of the write cycle. If this occurs, the system may possibly get an erroneous result, i.e., valid data may appear to conflict with either DQ<sub>7</sub> or DQ<sub>6</sub>. In order to prevent spurious rejection, if an erroneous result occurs, the software routine should include a loop to read the accessed location an additional two (2) times. If both reads are valid, then the device has completed the write cycle, otherwise the rejection is valid.

## Data# Polling (DQ<sub>7</sub>)

When the SST39VF160Q/VF160 are in the internal Program operation, any attempt to read DQ<sub>7</sub> will produce the complement of the true data. Once the Program operation is completed, DQ<sub>7</sub> will produce true data. The device is



# 16 Megabit Multi-Purpose Flash SST39VF160Q / SST39VF160

## Advance Information

then ready for the next operation. During internal Erase operation, any attempt to read DQ7 will produce a '0'. Once the internal Erase operation is completed, DQ7 will produce a '1'. The Data# Polling is valid after the rising edge of fourth WE# (or CE#) pulse for Program operation. For Sector or Chip Erase, the Data# Polling is valid after the rising edge of sixth WE# (or CE#) pulse. See Figure 6 for Data# Polling timing diagram and Figure 17 for a flowchart.

### Toggle Bit (DQ6)

During the internal Program or Erase operation, any consecutive attempts to read DQ6 will produce alternating 1's and 0's, i.e., toggling between 1 and 0. The toggle bit will begin with '1'. When the internal Program or Erase operation is completed, the DQ6 bit will stop toggling. The device is then ready for the next operation. The Toggle Bit is valid after the rising edge of fourth WE# (or CE#) pulse for Program operation. For Sector or Chip Erase, the Toggle Bit is valid after the rising edge of sixth WE# (or CE#) pulse. See Figure 7 for Toggle Bit timing diagram and Figure 18 for a flowchart.

### Data Protection

The SST39VF160Q/VF160 provide both hardware and software features to protect nonvolatile data from inadvertent writes.

#### Hardware Data Protection

Noise/Glitch Protection: A WE# or CE# pulse of less than 5 ns will not initiate a write cycle.

V<sub>DD</sub> Power Up/Down Detection: The Write operation is inhibited when V<sub>DD</sub> is less than 1.5V.

Write Inhibit Mode: Forcing OE# low, CE# high, or WE# high will inhibit the Write operation. This prevents inadvertent writes during power-up or power-down.

#### Software Data Protection (SDP)

The SST39VF160Q/VF160 provide the JEDEC approved Software Data Protection scheme for all data alteration operations, i.e., Program and Erase. Any Program operation requires the inclusion of the three byte sequence. The three byte-load sequence is used to initiate the Program operation, providing optimal protection from inadvertent Write operations, e.g., during the system power-up or power-down. Any Erase operation requires the inclusion of six byte sequence. The SST39VF160Q/VF160 device is shipped with the software data protection permanently enabled. See Table 4 for the specific software command codes. During SDP command sequence, invalid commands will abort the device to read mode within T<sub>RC</sub>. The contents of DQ<sub>15</sub>-DQ<sub>8</sub> are "Don't Care" during any SDP command sequence.

### Common Flash Memory Interface (CFI)

The SST39VF160Q/VF160 also contain the CFI information to describe the characteristics of the device. In order to enter the CFI query mode, the system must write 3 byte sequence, same as product ID entry command with 98H (CFI query command) to address 5555H in the last byte sequence. Once the device enters the CFI query mode, the system can read CFI data at the addresses given in tables 5 through 8. The system must write the reset command to return to read mode from the CFI query mode.

### Product Identification

The Product Identification mode identifies the devices as the SST39VF160Q, SST39VF160 and manufacturer as SST. This mode may be accessed by hardware or software operations. The hardware operation is typically used by a programmer to identify the correct algorithm for the SST39VF160Q/VF160. Users may wish to use the software product identification operation to identify the part (i.e., using the device code) when using multiple manufacturers in the same socket. For details, see Table 3 for hardware operation or Table 4 for software operation, Figure 9 for the software ID entry and read timing diagram and Figure 18 for the ID entry command sequence flowchart.

TABLE 1: PRODUCT IDENTIFICATION TABLE

	Address	Data
Manufacturer's Code	0000H	00BFH
Device Code	0001H	2782H

329 PGM T1.1

### Product Identification Mode Exit/CFI Mode Exit

In order to return to the standard Read mode, the Software Product Identification mode must be exited. Exit is accomplished by issuing the Software Exit ID command sequence, which returns the device to the Read operation. This command may also be used to reset the device to the read mode after any inadvertent transient condition that apparently causes the device to behave abnormally, e.g., not read correctly. Please note that the software reset command is ignored during an internal Program or Erase operation. See Table 4 for software command codes, Figure 13 for timing waveform and Figure 18 for a flowchart.

### V<sub>DDQ</sub> - I/O Power Supply

This feature is available only on the SST39VF160Q. This pin functions as power supply pin for input/output buffers. It should be tied to V<sub>DD</sub> (2.7V - 3.6V) in a 3.0V-only system. It should be tied to a 5.0V±10% (4.5V - 5.5V) power supply in a mixed voltage system environment where flash memory has to be interfaced with 5V system chips. The V<sub>DDQ</sub> pin is not offered on the SST39VF160, instead it is a No Connect pin.



# 16 Megabit Multi-Purpose Flash SST39VF160Q / SST39VF160

Advance Information

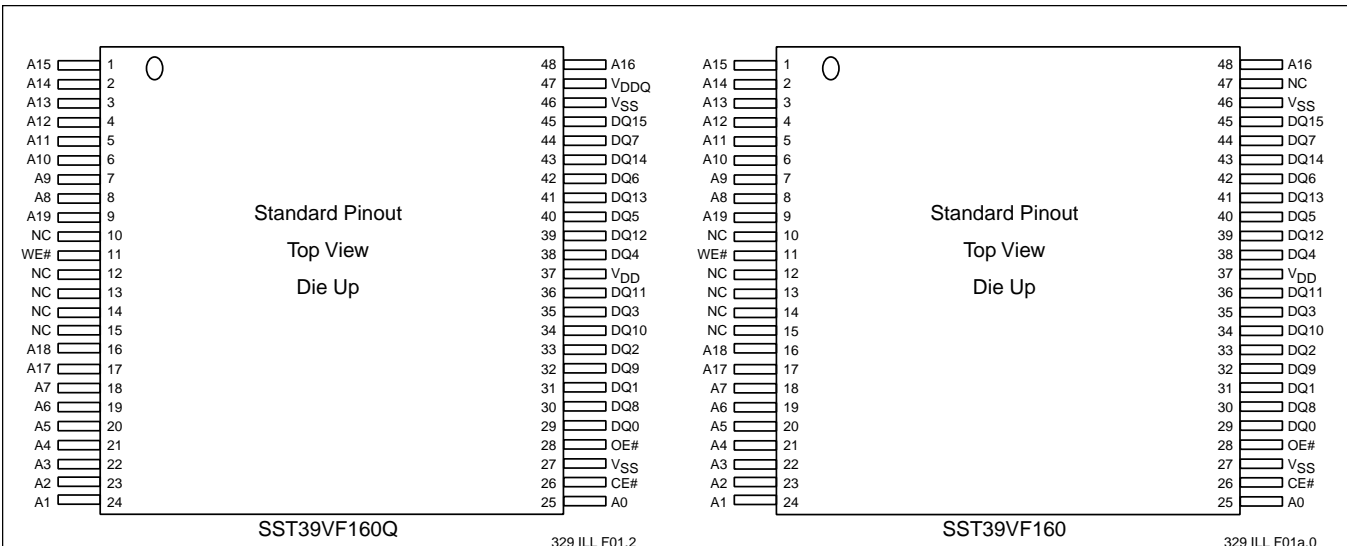
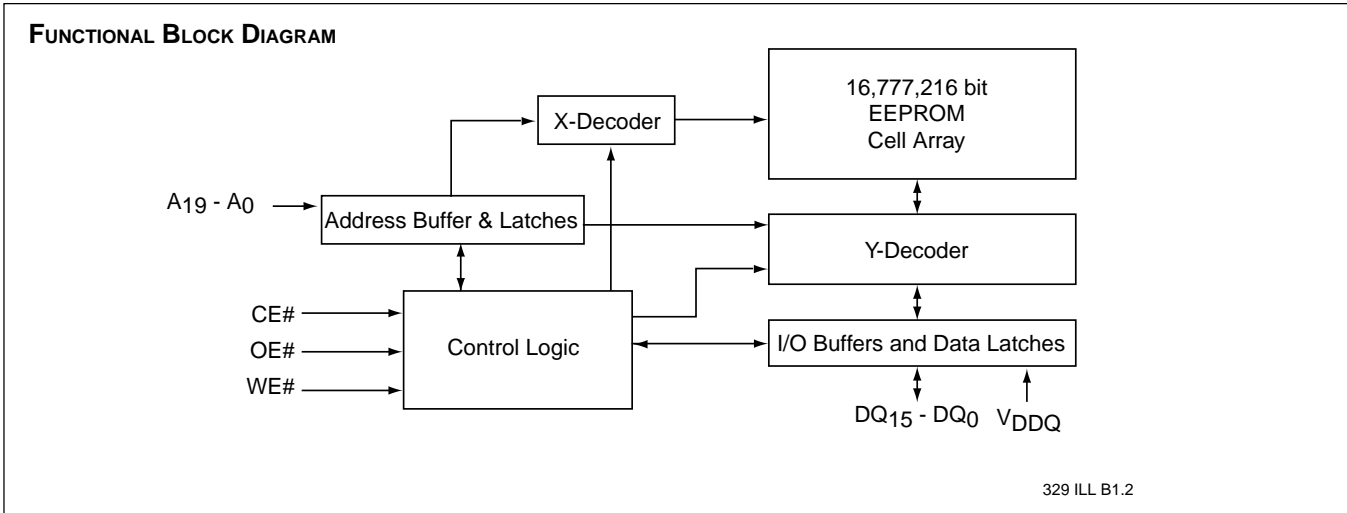

**FIGURE 1: PIN ASSIGNMENTS FOR 48-PIN TSOP PACKAGES**

	1	2	3	4	5	6		1	2	3	4	5	6
<b>A</b>	A3	A7	NC	WE#	A9	A13	<b>A</b>	A3	A7	NC	WE#	A9	A13
<b>B</b>	A4	A17	NC	NC	A8	A12	<b>B</b>	A4	A17	NC	NC	A8	A12
<b>C</b>	A2	A6	A18	NC	A10	A14	<b>C</b>	A2	A6	A18	NC	A10	A14
<b>D</b>	A1	A5	NC	A19	A11	A15	<b>D</b>	A1	A5	NC	A19	A11	A15
<b>E</b>	A0	DQ0	DQ2	DQ5	DQ7	A16	<b>E</b>	A0	DQ0	DQ2	DQ5	DQ7	A16
<b>F</b>	CE#	DQ8	DQ10	DQ12	DQ14	VDDQ	<b>F</b>	CE#	DQ8	DQ10	DQ12	DQ14	NC
<b>G</b>	OE#	DQ9	DQ11	VDD	DQ13	DQ15	<b>G</b>	OE#	DQ9	DQ11	VDD	DQ13	DQ15
<b>H</b>	VSS	DQ1	DQ3	DQ4	DQ6	VSS	<b>H</b>	VSS	DQ1	DQ3	DQ4	DQ6	VSS

SST39VF160Q 329 ILL F02.4
SST39VF160 329 ILL F02a.0

**FIGURE 2: PIN ASSIGNMENTS FOR 48-PIN TFBGA**



# 16 Megabit Multi-Purpose Flash SST39VF160Q / SST39VF160

## Advance Information

**TABLE 2: PIN DESCRIPTION**

Symbol	Pin Name	Functions
A <sub>19</sub> -A <sub>0</sub>	Address Inputs	To provide memory addresses. During sector erase A <sub>19</sub> -A <sub>11</sub> address lines will select the sector. During block erase A <sub>19</sub> -A <sub>15</sub> address lines will select the block.
DQ <sub>15</sub> -DQ <sub>0</sub>	Data Input/output	To output data during read cycles and receive input data during write cycles. Data is internally latched during a write cycle. The outputs are in tri-state when OE# or CE# is high.
CE#	Chip Enable	To activate the device when CE# is low.
OE#	Output Enable	To gate the data output buffers.
WE#	Write Enable	To control the write operations.
V <sub>DD</sub>	Power Supply	To provide 3-volt supply (2.7-3.6V)
V <sub>DDQ</sub>	I/O Power Supply	Supplies power for input/output buffers. It should be either tied to V <sub>DD</sub> (2.7 - 3.6V) for 3V I/O or to a 5.0V (4.5V - 5.5V) power supply to support 5V I/O. (Not offered on SST39VF160 device, instead it is a NC)
V <sub>SS</sub>	Ground	
NC	No Connection	Unconnected pins.

329 PGM T2.6

**TABLE 3: OPERATION MODES SELECTION**

Mode	CE#	OE#	WE#	A <sub>9</sub>	DQ	Address
Read	V <sub>IL</sub>	V <sub>IL</sub>	V <sub>IH</sub>	A <sub>IN</sub>	D <sub>OUT</sub>	A <sub>IN</sub>
Program	V <sub>IL</sub>	V <sub>IH</sub>	V <sub>IL</sub>	A <sub>IN</sub>	D <sub>IN</sub>	A <sub>IN</sub>
Erase	V <sub>IL</sub>	V <sub>IH</sub>	V <sub>IL</sub>	X	X	Sector or block address, XXh for chip erase
Standby	V <sub>IH</sub>	X	X	X	High Z	X
Write Inhibit	X	V <sub>IL</sub>	X	X	High Z/ D <sub>OUT</sub>	X
Write Inhibit	X	X	V <sub>IH</sub>	X	High Z/ D <sub>OUT</sub>	X
Product Identification						
Hardware Mode	V <sub>IL</sub>	V <sub>IL</sub>	V <sub>IH</sub>	V <sub>H</sub>	Manufacturer Code (00BF) Device Code (2782)	A <sub>19</sub> - A <sub>1</sub> = V <sub>IL</sub> , A <sub>0</sub> = V <sub>IL</sub> A <sub>19</sub> - A <sub>1</sub> = V <sub>IL</sub> , A <sub>0</sub> = V <sub>IH</sub>
Software Mode	V <sub>IL</sub>	V <sub>IL</sub>	V <sub>IH</sub>	A <sub>IN</sub>		See Table 4

329 PGM T3.2





# 16 Megabit Multi-Purpose Flash SST39VF160Q / SST39VF160

Advance Information

**TABLE 4: SOFTWARE COMMAND SEQUENCE**

Command Sequence	1st Bus Write Cycle		2nd Bus Write Cycle		3rd Bus Write Cycle		4th Bus Write Cycle		5th Bus Write Cycle		6th Bus Write Cycle	
	Addr <sup>(1)</sup>	Data	Addr <sup>(1)</sup>	Data	Addr <sup>(1)</sup>	Data	Addr <sup>(1)</sup>	Data	Addr <sup>(1)</sup>	Data	Addr <sup>(1)</sup>	Data
Word Program	5555H	AAH	2AAAH	55H	5555H	A0H	WA <sup>(3)</sup>	Data				
Sector Erase	5555H	AAH	2AAAH	55H	5555H	80H	5555H	AAH	2AAAH	55H	SA <sub>x</sub> <sup>(2)</sup>	30H
Block Erase	5555H	AAH	2AAAH	55H	5555H	80H	5555H	AAH	2AAAH	55H	BA <sub>x</sub> <sup>(2)</sup>	50H
Chip Erase	5555H	AAH	2AAAH	55H	5555H	80H	5555H	AAH	2AAAH	55H	5555H	10H
Software ID Entry	5555H	AAH	2AAAH	55H	5555H	90H						
CFI Query Entry	5555H	AAH	2AAAH	55H	5555H	98H						
Software ID Exit/ CFI Exit	XXH	F0H										
Software ID Exit/ CFI Exit	5555H	AAH	2AAAH	55H	5555H	F0H						

329 PGM T4.2

- Notes:**
- (1) Address format A<sub>14</sub>-A<sub>0</sub> (Hex), Addresses A<sub>15</sub>, A<sub>16</sub>, A<sub>17</sub>, A<sub>18</sub> and A<sub>19</sub> are "Don't Care" for Command sequence.
  - (2) SA<sub>x</sub> for sector erase; uses A<sub>19</sub>-A<sub>11</sub> address lines  
BA<sub>x</sub>, for block erase; uses A<sub>19</sub>-A<sub>15</sub> address lines
  - (3) WA = Program word address
  - (4) Both Software ID Exit operations are equivalent
  - (5) DQ<sub>15</sub> - DQ<sub>8</sub> are "Don't Care" for Command sequence

**Notes for Software ID Entry Command Sequence**

1. With A<sub>19</sub>-A<sub>1</sub>=0; SST Manufacturer Code = 00BFH, is read with A<sub>0</sub> = 0,  
SST39VF160Q/VF160 Device Code = 2782H, is read with A<sub>0</sub> = 1.
2. The device does not remain in Software Product ID Mode if powered down.

**TABLE 5: CFI QUERY IDENTIFICATION STRING**

Address	Data	Data
10H 11H 12H	0051H 0052H 0059H	Query Unique ASCII string "QRY"
13H 14H	0001H 0007H	Primary OEM command set
15H 16H	0000H 0000H	Address for Primary Extended Table
17H 18H	0000H 0000H	Alternate OEM command set (00H = none exists)
19H 1AH	0000H 0000H	Address for Alternate OEM extended Table (00H = none exists)

329 PGM T5.2



# 16 Megabit Multi-Purpose Flash SST39VF160Q / SST39VF160

Advance Information

**TABLE 6: SYSTEM INTERFACE INFORMATION**

Address	Data	Data
1BH	0027H	Vdd Min. (Program/erase) DQ4-DQ7: Volts, DQ3-DQ0: millivolts
1CH	0036H	Vdd Max. (Program/erase) DQ4-DQ7: Volts, DQ3-DQ0: millivolts
1DH	0000H	Vpp min. (00H = no Vpp pin)
1EH	0000H	Vpp max. (00H = no Vpp pin)
1FH	0003H	Typical time out for word program $2^N$ $\mu$ s
20H	0000H	Typical time out for min. size buffer program $2^N$ $\mu$ s (00H = not supported)
21H	0001H	Typical time out for individual sector erase $2^N$ ms
22H	0009H	Typical time out for chip erase $2^N$ ms
23H	0001H	Maximum time out for word program $2^N$ times typical
24H	0000H	Maximum time out for buffer program $2^N$ times typical
25H	0001H	Maximum time out for individual sector erase $2^N$ times typical
26H	0001H	Maximum time out for chip erase $2^N$ times typical

329 PGM T6.2

**TABLE 7: DEVICE GEOMETRY INFORMATION**

Address	Data	Data
27H	0015H	Device size = $2^N$ byte
28H	0001H	Flash Device Interface description (Refer to CFI publication 100)
29H	0000H	
2AH	0000H	Maximum number of byte in multi-byte write = $2^N$ (00H = not supported)
2BH	0000H	
2CH	0002H	Number of Erase Block Regions within device
2DH	00FFH	Erase Block Region 1 Information (refer to the CFI specification or publication 100) y = 511 + 1 = 512 sectors (01FF = 511) z = 16 x 256 bytes = 4K bytes/sector (0010H = 16)
2EH	0001H	
2FH	0010H	
30H	0000H	
31H	001FH	Erase Block Region 2 Information (refer to the CFI specification or publication 100) y = 31 + 1 = 32 blocks (001F = 31) z = 256 x 256 bytes = 64K bytes/block (0100H = 256)
32H	0000H	
33H	0000H	
34H	0001H	
35H	0000H	Erase Block Region 3 Information (refer to the CFI specification or publication 100)
36H	0000H	
37H	0000H	
38H	0000H	
39H	0000H	Erase Block Region 3 Information (refer to the CFI specification or publication 100)
3AH	0000H	
3BH	0000H	
3CH	0000H	

329 PGM T7.3



# 16 Megabit Multi-Purpose Flash SST39VF160Q / SST39VF160

Advance Information

**Absolute Maximum Stress Ratings** (Applied conditions greater than those listed under “Absolute Maximum Stress Ratings” may cause permanent damage to the device. This is a stress rating only and functional operation of the device at these conditions or conditions greater than those defined in the operational sections of this data sheet is not implied. Exposure to absolute maximum stress rating conditions may affect device reliability.)

Temperature Under Bias .....	-55°C to +125°C
Storage Temperature .....	-65°C to +150°C
D. C. Voltage on Any Pin to Ground Potential .....	-0.5V to $V_{DDQ}^{(2)} + 0.5V$
Transient Voltage (<20 ns) on Any Pin to Ground Potential .....	-1.0V to $V_{DDQ}^{(2)} + 1.0V$
Voltage on A <sub>9</sub> Pin to Ground Potential .....	-0.5V to 13.2V
Package Power Dissipation Capability (Ta = 25°C) .....	1.0W
Surface Mount Lead Soldering Temperature (3 Seconds) .....	240°C
Output Short Circuit Current <sup>(1)</sup> .....	50 mA

**Note:** <sup>(1)</sup> Outputs shorted for no more than one second. No more than one output shorted at a time.  
<sup>(2)</sup> The absolute maximum stress ratings for SST39VF160 are referenced to  $V_{DD}$ .

### OPERATING RANGE

Range	Ambient Temp	$V_{DD}$	$V_{DDQ}$
Commercial	0 °C to +70 °C	2.7V - 3.6V	$V_{DD}$ or 4.5V - 5.5V
Industrial	-40 °C to +85 °C	2.7V - 3.6V	$V_{DD}$ or 4.5V - 5.5V

### AC CONDITIONS OF TEST

Input Rise/Fall Time .....	10 ns
Output Load .....	1 TTL Gate and $C_L = 100$ pF
See Figures 14 and 15	





# 16 Megabit Multi-Purpose Flash SST39VF160Q / SST39VF160

Advance Information

**TABLE 8: DC OPERATING CHARACTERISTICS  $V_{DD} = 2.7-3.6V$  AND  $V_{DDQ} = V_{DD}$  OR  $4.5V - 5.5V$**

Symbol	Parameter	Limits			Test Conditions
		Min	Max	Units	
$I_{DD}$	Power Supply Current Read Program and Erase		20 25	mA mA	$CE\#=OE\#=V_{IL}, WE\#=V_{IH}$ , all I/Os open, Address input = $V_{IL}/V_{IH}$ , at $f=1/T_{RC}$ Min. $CE\#=WE\#=V_{IL}, OE\#=V_{IH}, V_{DD}=V_{DD}$ Max.
$I_{SB}$	Standby $V_{DD}$ Current		10	$\mu A$	$CE\#=V_{IHC}, V_{DD} = V_{DD}$ Max.
$I_{ALP}$	Auto Low Power Current		10	$\mu A$	$CE\#=V_{IHC}, V_{DD} = V_{DD}$ Max.
$I_{LI}$	Input Leakage Current		1	$\mu A$	$V_{IN} = GND$ to $V_{DD}, V_{DD} = V_{DD}$ Max.
$I_{LO}$	Output Leakage Current		1	$\mu A$	$V_{OUT} = GND$ to $V_{DD}, V_{DD} = V_{DD}$ Max.
$V_{IL}$	Input Low Voltage		0.8	V	$V_{DD} = V_{DD}$ Max.
$V_{ILC}$	Input Low Voltage (CMOS)	0.3		V	$V_{DD} = V_{DD}$ Max.
$V_{IH}$	Input High Voltage	2.0		V	$V_{DD} = V_{DD}$ Max.
$V_{IHC}$	Input High Voltage (CMOS)	$V_{DD}-0.3$		V	$V_{DD} = V_{DD}$ Max.
$V_{OL}$	Output Low Voltage		0.4	V	$I_{OL} = 100 \mu A, V_{DD} = V_{DD}$ Min.
$V_{OH}$	Output High Voltage	2.4		V	$I_{OH} = -100 \mu A, V_{DD} = V_{DD}$ Min.
$V_H$	Supervoltage for $A_9$ pin	11.4	12.6	V	$CE\# = OE\# = V_{IL}, WE\# = V_{IH}$
$I_H$	Supervoltage Current for $A_9$ pin		200	$\mu A$	$CE\# = OE\# = V_{IL}, WE\# = V_{IH}, A_9 = V_H$ Max.

329 PGM T9.8

**TABLE 9: RECOMMENDED SYSTEM POWER-UP TIMINGS**

Symbol	Parameter	Minimum	Units
$T_{PU-READ}^{(1)}$	Power-up to Read Operation	100	$\mu s$
$T_{PU-WRITE}^{(1)}$	Power-up to Program/Erase Operation	100	$\mu s$

329 PGM T10.2

**TABLE 10: CAPACITANCE ( $T_a = 25^\circ C, f=1$  Mhz, other pins open)**

Parameter	Description	Test Condition	Maximum (TSOP)	Maximum (TFBGA)
$C_{I/O}^{(1)}$	I/O Pin Capacitance	$V_{I/O} = 0V$	12 pF	12pF
$C_{IN}^{(1)}$	Input Capacitance	$V_{IN} = 0V$	6 pF	6pF

329 PGM T11.1

**Note:** (1) This parameter is measured only for initial qualification and after a design or process change that could affect this parameter.

**TABLE 11: RELIABILITY CHARACTERISTICS**

Symbol	Parameter	Minimum Specification	Units	Test Method
$N_{END}^{(1)}$	Endurance	10,000	Cycles	MIL-STD-883, Method 1033
$T_{DR}^{(1)}$	Data Retention	100	Years	JEDEC Standard A103
$V_{ZAP\_HBM}^{(1)}$	ESD Susceptibility Human Body Model	1000	Volts	JEDEC Standard A114
$V_{ZAP\_MM}^{(1)}$	ESD Susceptibility Machine Model	200	Volts	JEDEC Standard A115
$I_{LTH}^{(1)}$	Latch Up	$100 + I_{DD}$	mA	JEDEC Standard 78

329 PGM T12.2

**Note:** (1) This parameter is measured only for initial qualification and after a design or process change that could affect this parameter.



AC CHARACTERISTICS

TABLE 12: SST39VF160Q/VF160 READ CYCLE TIMING PARAMETERS  $V_{DD} = 2.7-3.6V$

Symbol	Parameter	SST39VF160Q/VF160-70		SST39VF160Q/VF160-90		Units
		Min	Max	Min	Max	
$T_{RC}$	Read Cycle time	70		90		ns
$T_{CE}$	Chip Enable Access Time		70		90	ns
$T_{AA}$	Address Access Time		70		90	ns
$T_{OE}$	Output Enable Access Time		30		40	ns
$T_{CLZ}^{(1)}$	CE# Low to Active Output	0		0		ns
$T_{OLZ}^{(1)}$	OE# Low to Active Output	0		0		ns
$T_{CHZ}^{(1)}$	CE# High to High-Z Output		20		30	ns
$T_{OHZ}^{(1)}$	OE# High to High-Z Output		20		30	ns
$T_{OH}^{(1)}$	Output Hold from Address Change	0		0		ns

329 PGM T13.1

TABLE 13: PROGRAM/ERASE CYCLE TIMING PARAMETERS

Symbol	Parameter	Min	Max	Units
$T_{BP}$	Word Program time		10	$\mu s$
$T_{AS}$	Address Setup Time	0		ns
$T_{AH}$	Address Hold Time	30		ns
$T_{CS}$	WE# and CE# Setup Time	0		ns
$T_{CH}$	WE# and CE# Hold Time	0		ns
$T_{OES}$	OE# High Setup Time	0		ns
$T_{OEH}$	OE# High Hold Time	0		ns
$T_{CP}$	CE# Pulse Width	40		ns
$T_{WP}$	WE# Pulse Width	40		ns
$T_{WPH}^{(1)}$	WE# Pulse Width High	30		ns
$T_{CPH}^{(1)}$	CE# Pulse Width High	30		ns
$T_{DS}$	Data Setup Time	30		ns
$T_{DH}^{(1)}$	Data Hold Time	0		ns
$T_{IDA}^{(1)}$	Software ID Access and Exit Time		150	ns
$T_{SE}$	Sector Erase		4	ms
$T_{BE}$	Block Erase		10	ms
$T_{SCE}$	Chip Erase		20	ms

329 PGM T14.2

Note: <sup>(1)</sup> This parameter is measured only for initial qualification and after the design or process change that could affect this parameter.



# 16 Megabit Multi-Purpose Flash SST39VF160Q / SST39VF160

Advance Information

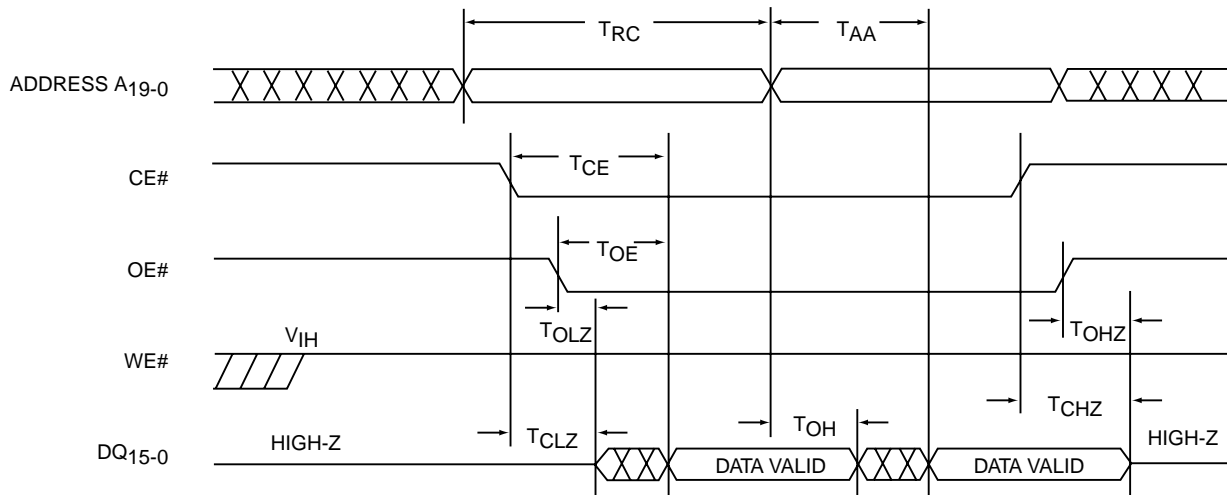

329 ILL F03.1

FIGURE 3: READ CYCLE TIMING DIAGRAM

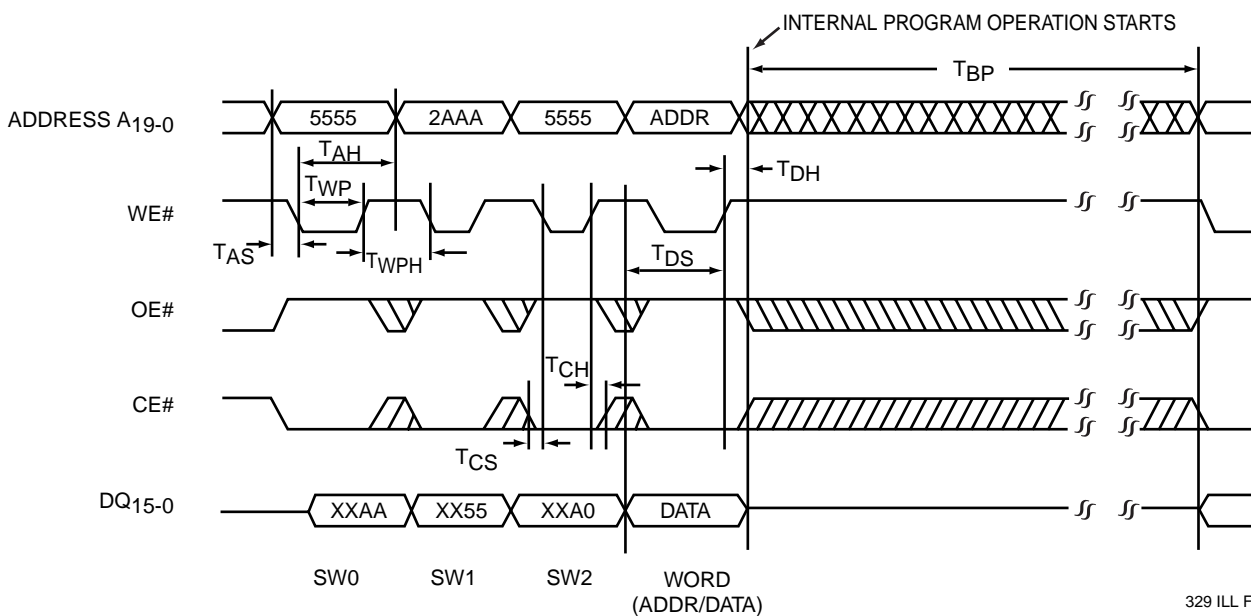

329 ILL F04.1

FIGURE 4: WE# CONTROLLED PROGRAM CYCLE TIMING DIAGRAM

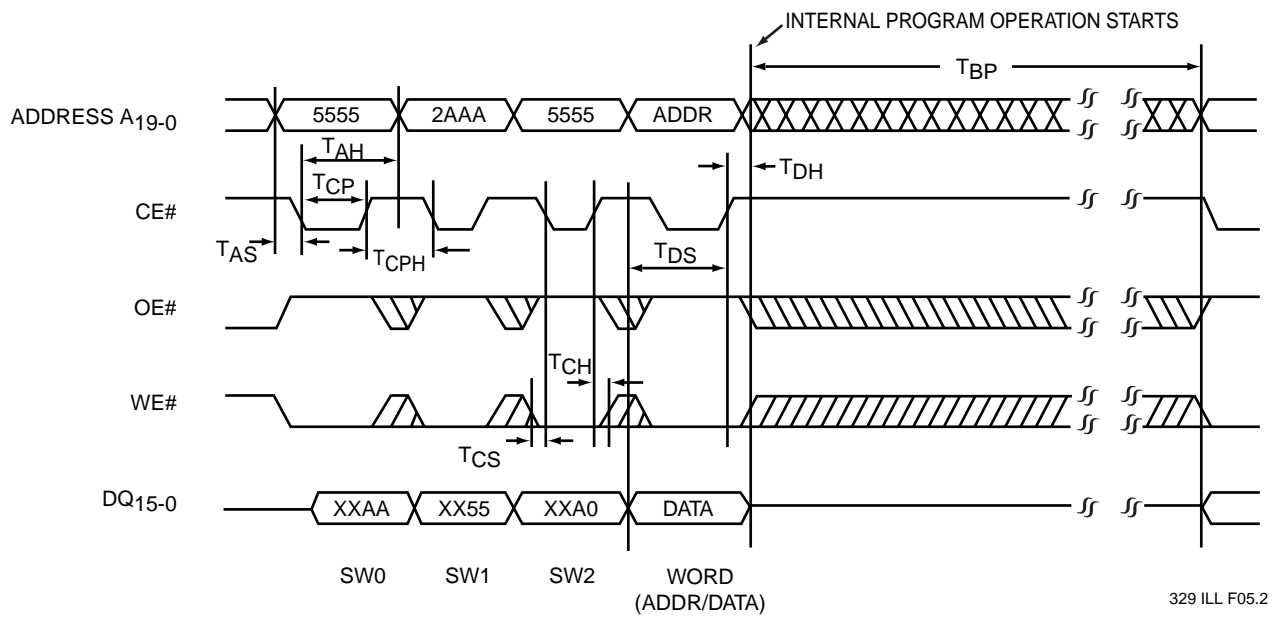

FIGURE 5: CE# CONTROLLED PROGRAM CYCLE TIMING DIAGRAM

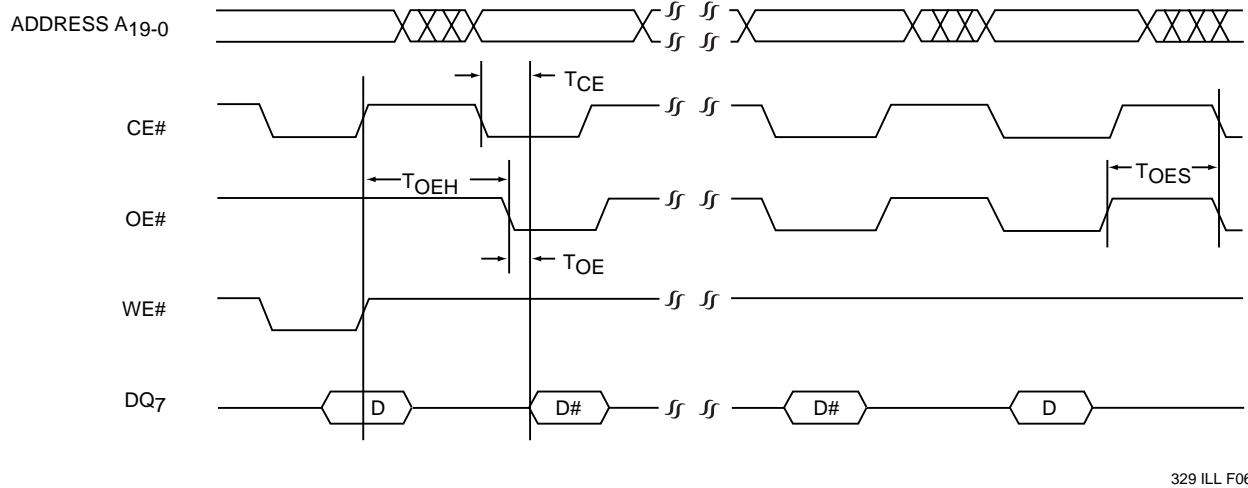

FIGURE 6: DATA# POLLING TIMING DIAGRAM



# 16 Megabit Multi-Purpose Flash SST39VF160Q / SST39VF160

Advance Information

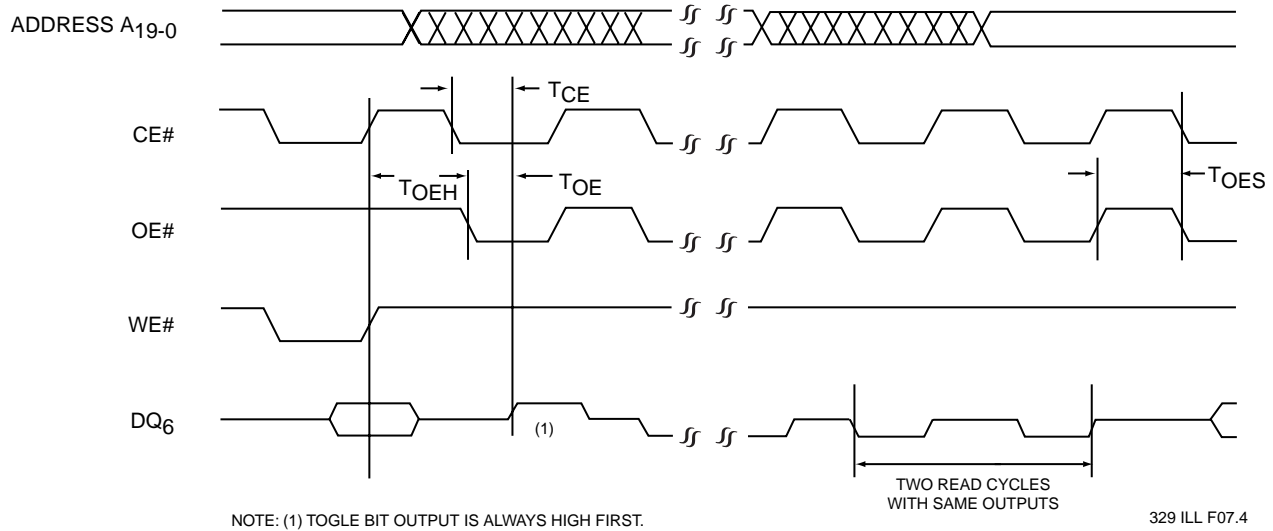
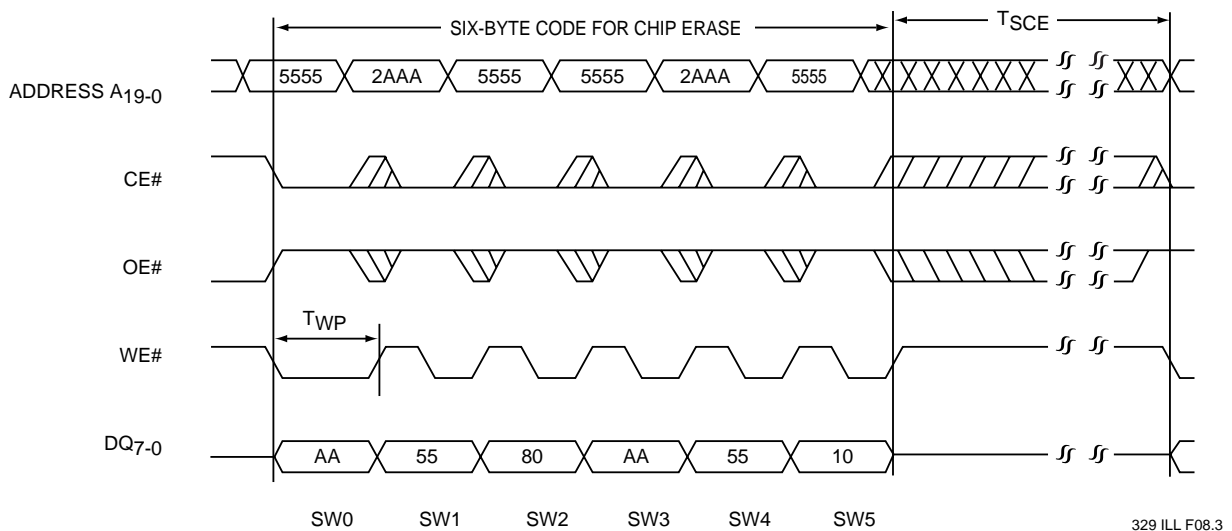
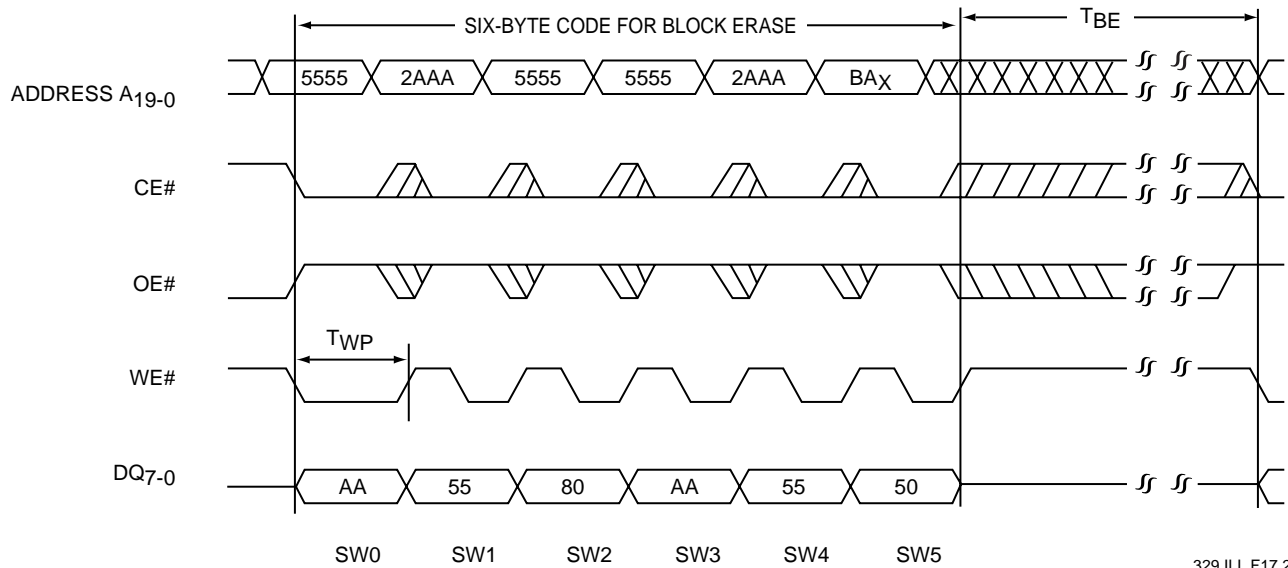

FIGURE 7: TOGGLE BIT TIMING DIAGRAM



Note: The device also supports CE# controlled chip erase operation. The WE# and CE# signals are interchangeable as long as minimum timings are met. (See Table 13)

FIGURE 8: WE# CONTROLLED CHIP ERASE TIMING DIAGRAM



Note: The device also supports CE# controlled block erase operation. The WE# and CE# signals are interchangeable as long as minimum timings are met. (See Table 13)  
BA<sub>x</sub> = Block Address

FIGURE 9: WE# CONTROLLED BLOCK ERASE TIMING DIAGRAM

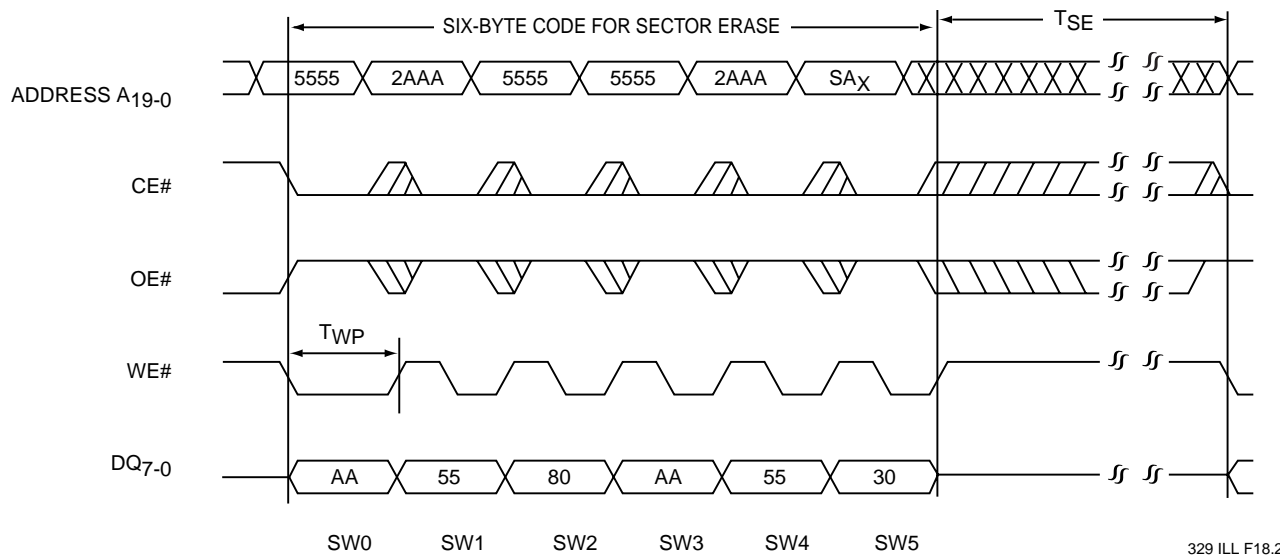

Note: The device also supports CE# controlled sector erase operation. The WE# and CE# signals are interchangeable as long as minimum timings are met. (See Table 13)  
SA<sub>x</sub> = Sector Address

FIGURE 10: WE# CONTROLLED SECTOR ERASE TIMING DIAGRAM





# 16 Megabit Multi-Purpose Flash SST39VF160Q / SST39VF160

Advance Information

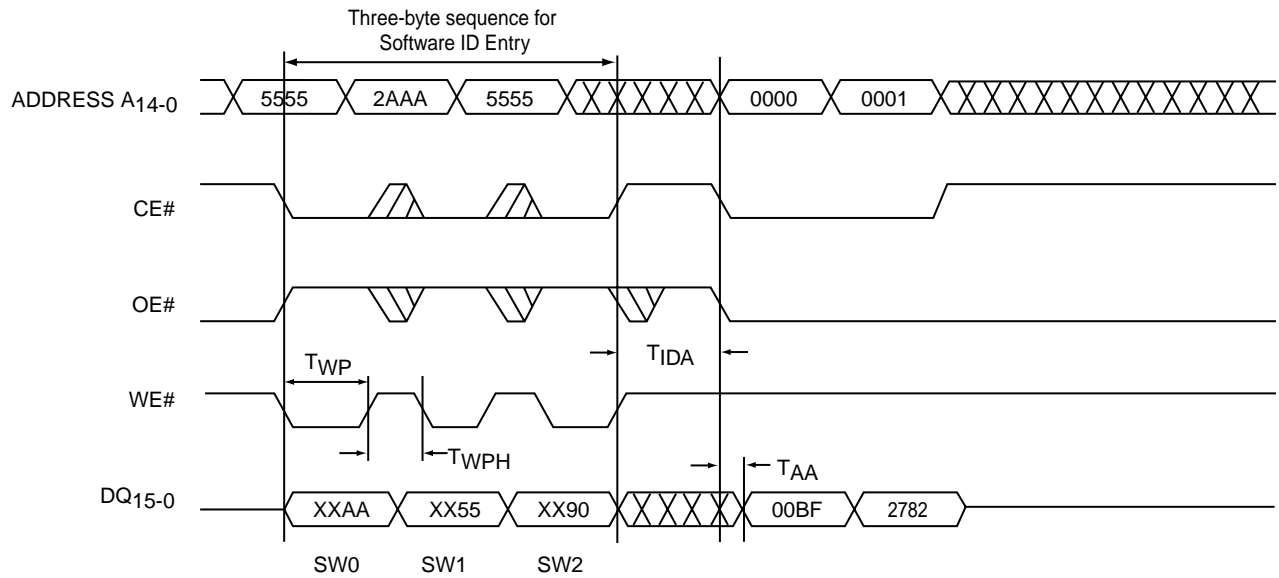

329 ILL F09.2

FIGURE 11: SOFTWARE ID ENTRY AND READ

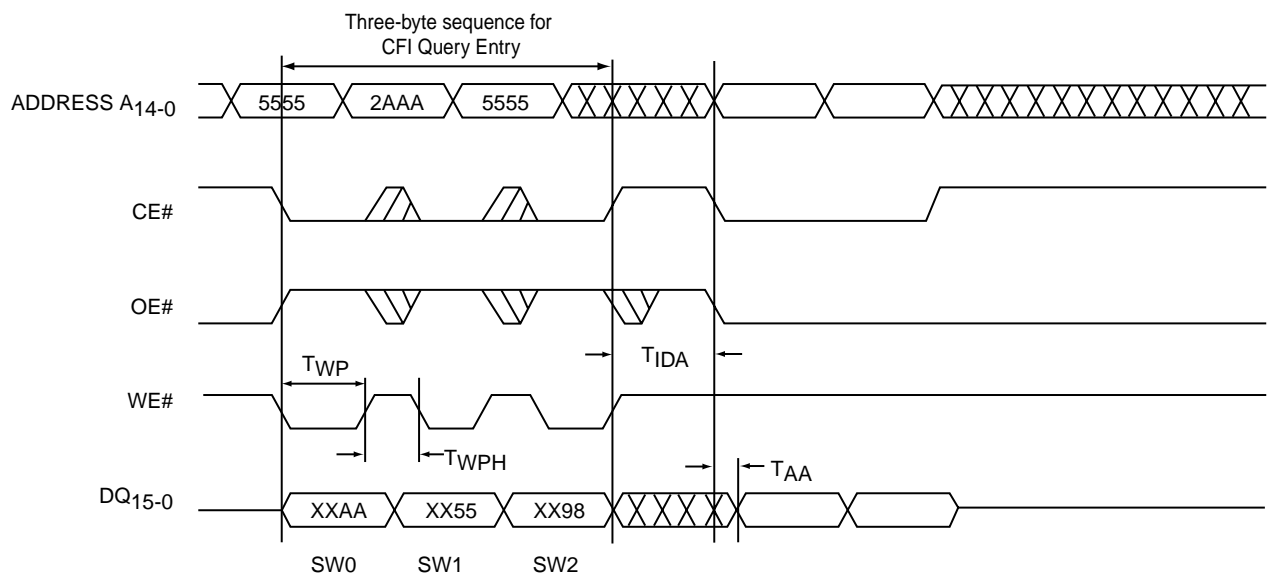

329 ILL F20.0

FIGURE 12: CFI QUERY ENTRY AND READ

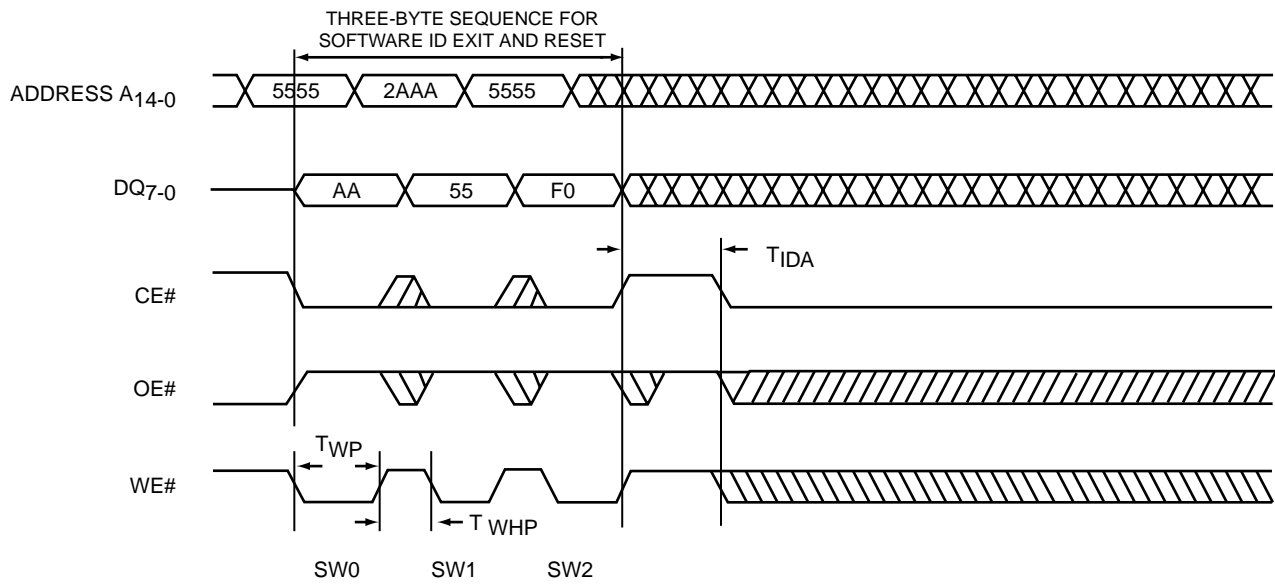

329 ILL F10.0

FIGURE 13: SOFTWARE ID EXIT/CFI EXIT



# 16 Megabit Multi-Purpose Flash SST39VF160Q / SST39VF160

Advance Information

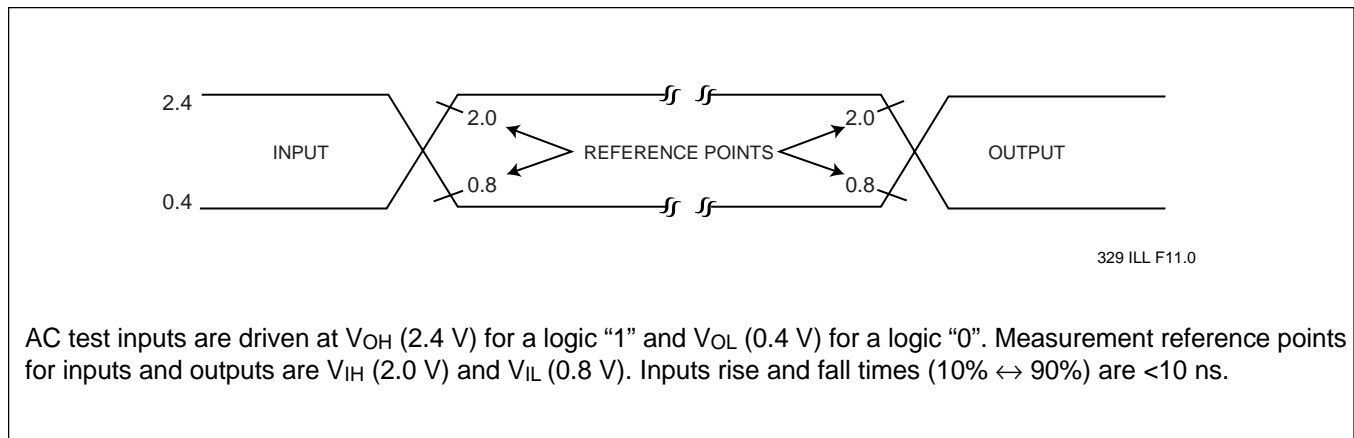

**FIGURE 14: AC INPUT/OUTPUT REFERENCE WAVEFORMS**

Test conditions:

Output load: 100 pF

Input rise and fall time: 10 ns

Measurement reference level: 0.8 and 2.0 V

Input levels: 0.4 V to 2.4 V

Temperature: Commercial or Industrial

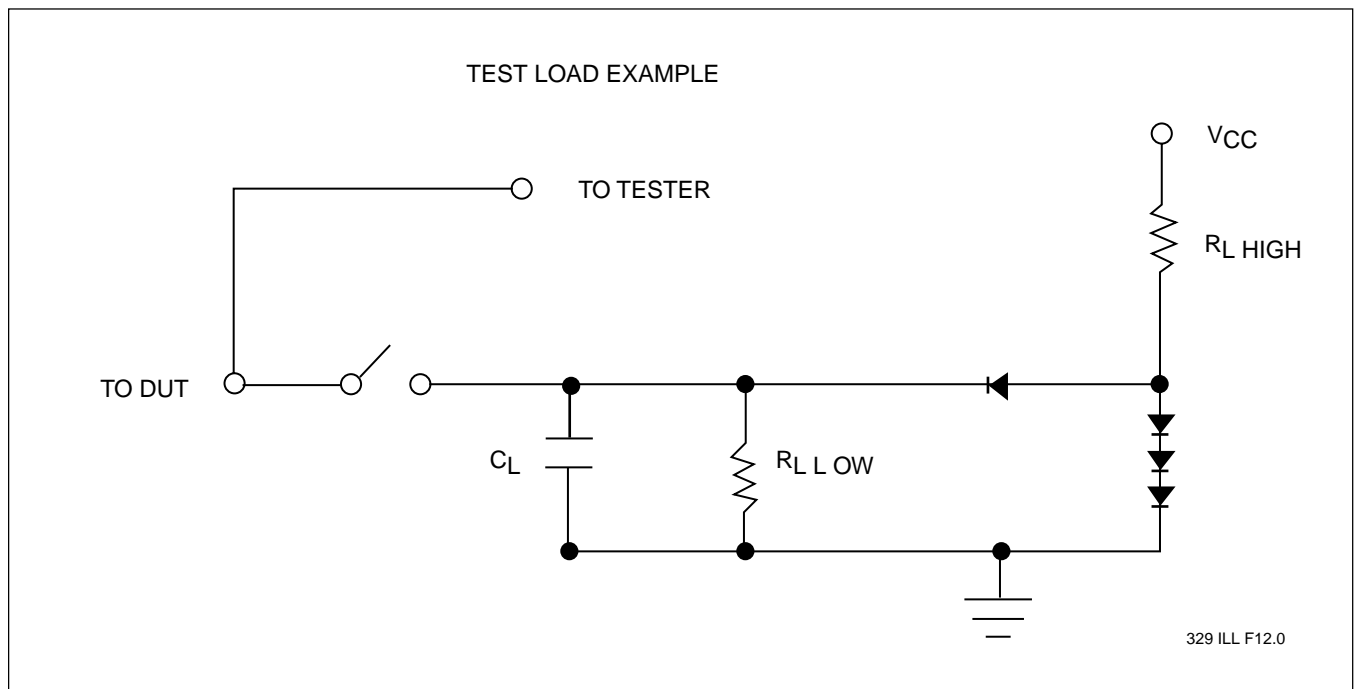

**FIGURE 15: TEST LOAD EXAMPLE**

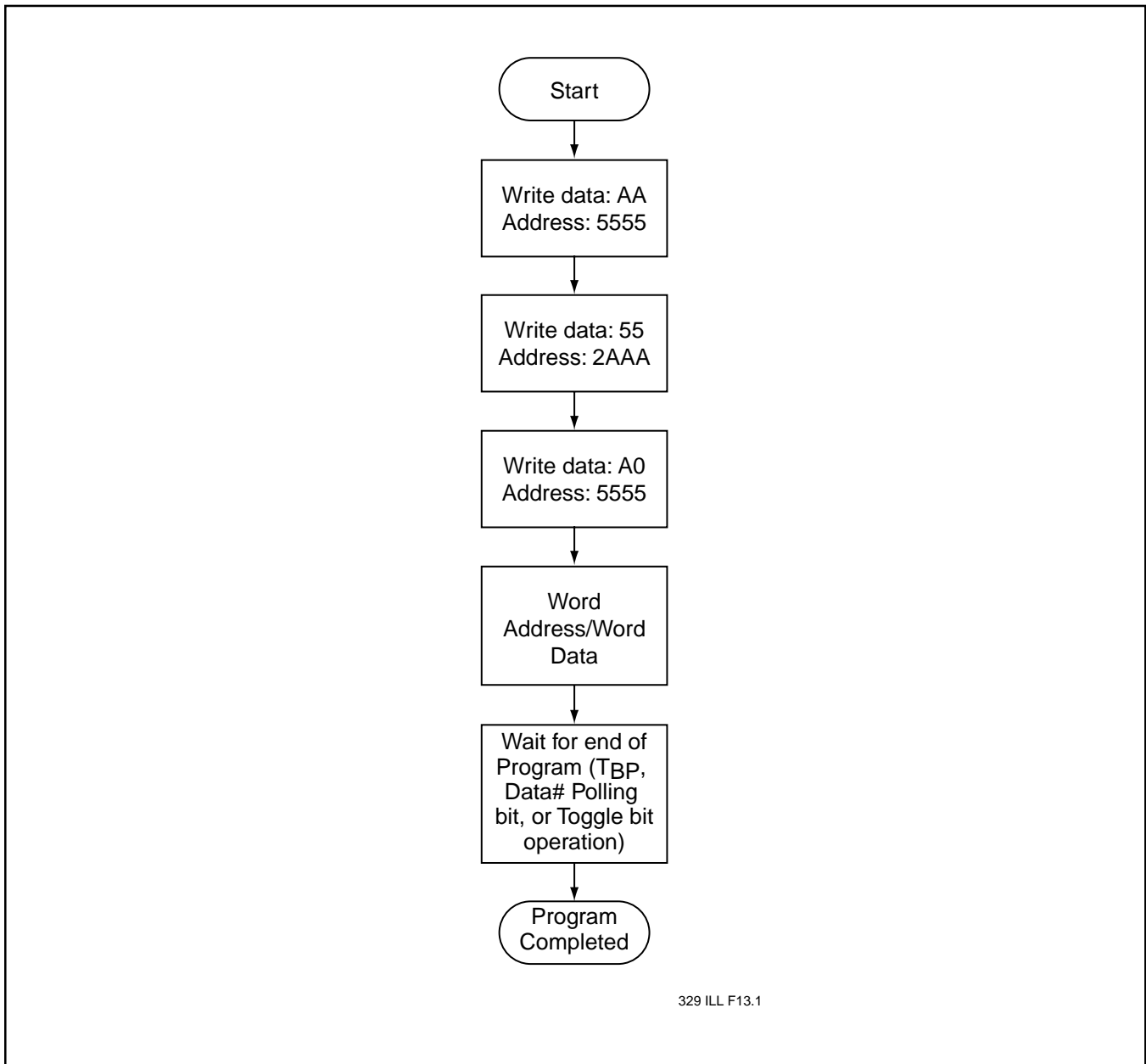

FIGURE 16: WORD PROGRAM ALGORITHM



# 16 Megabit Multi-Purpose Flash SST39VF160Q / SST39VF160

Advance Information

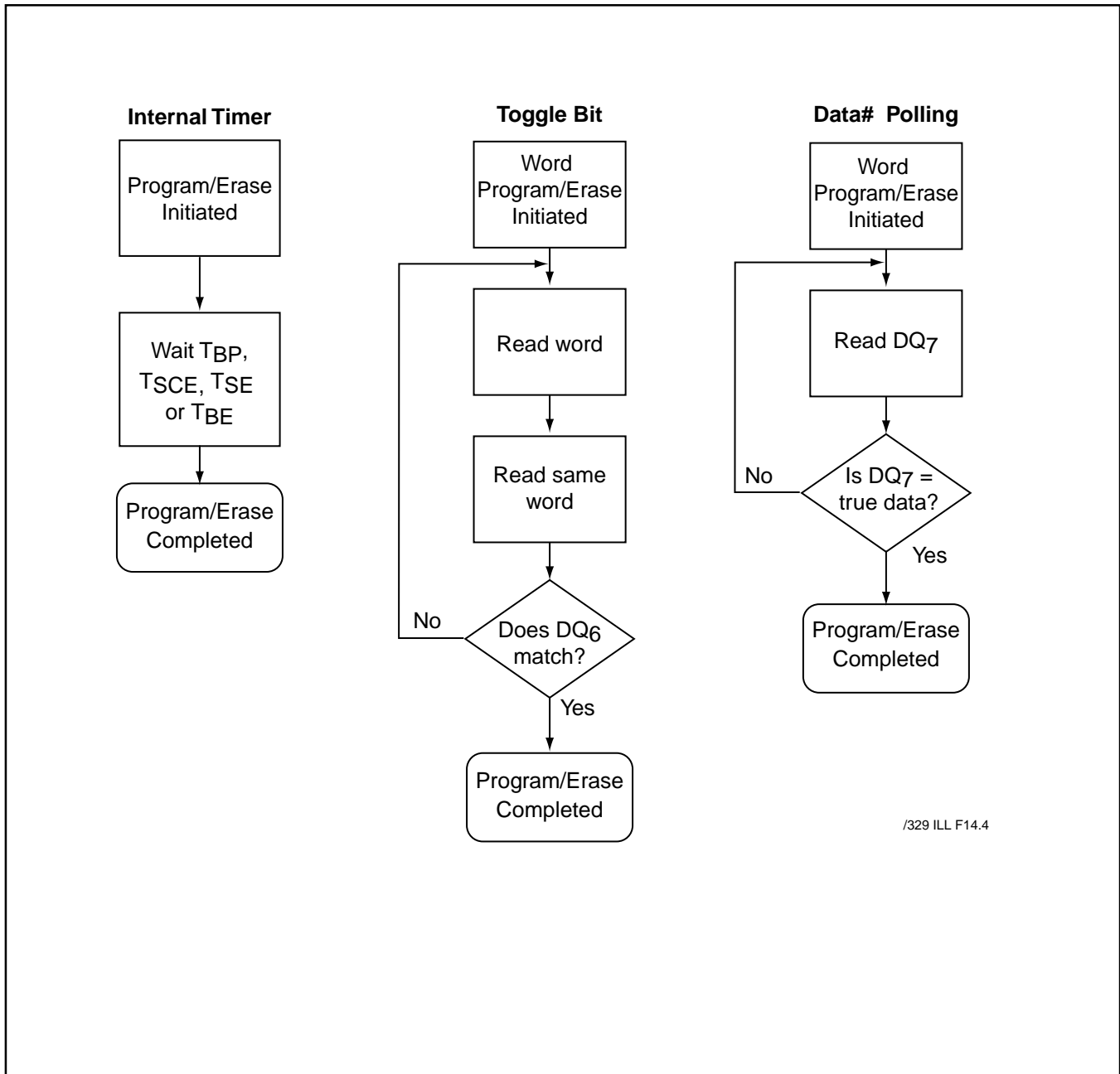

FIGURE 17: WAIT OPTIONS

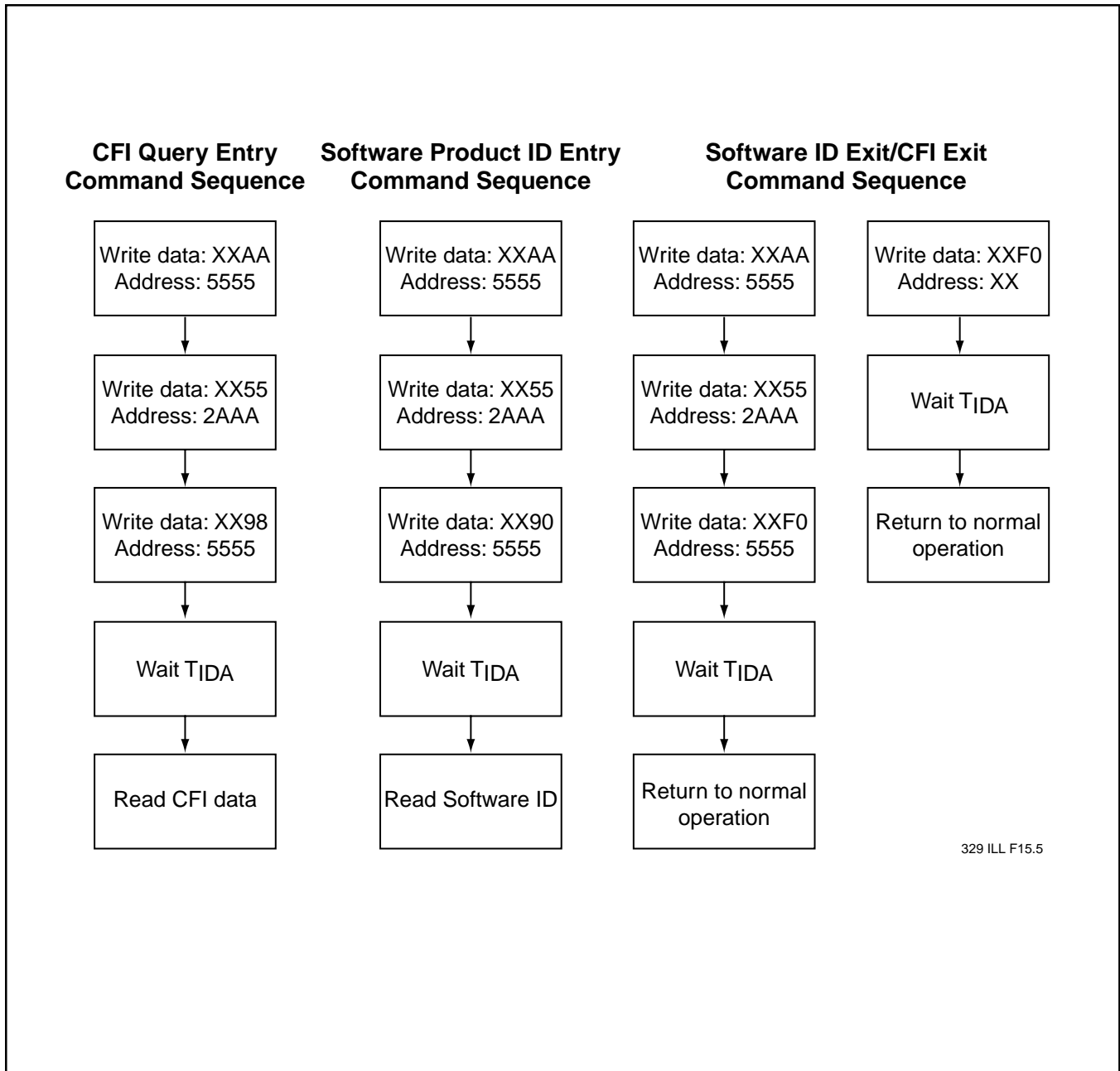

FIGURE 18: SOFTWARE PRODUCT ID/CFI COMMAND FLOWCHARTS





# 16 Megabit Multi-Purpose Flash SST39VF160Q / SST39VF160

Advance Information

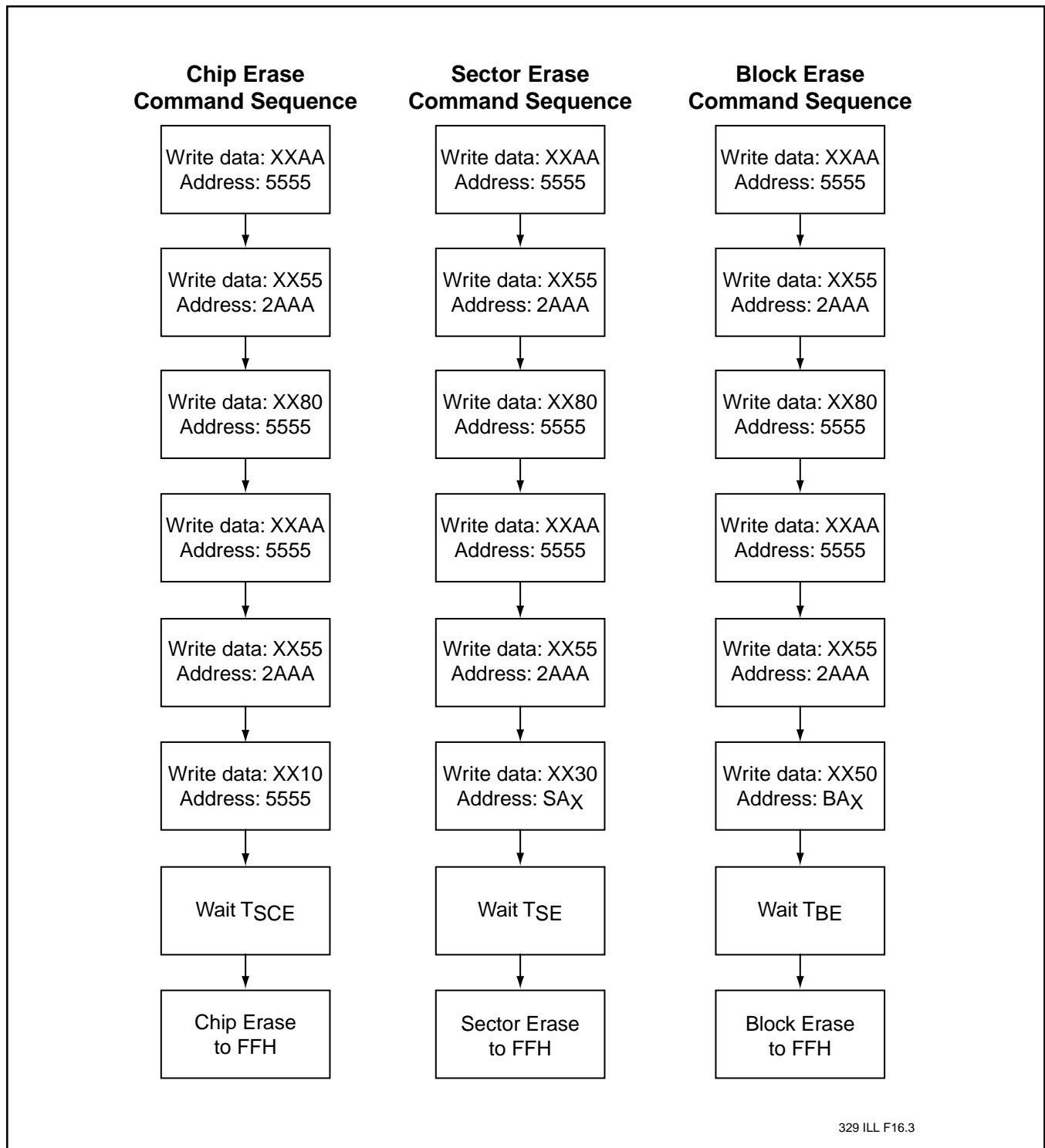
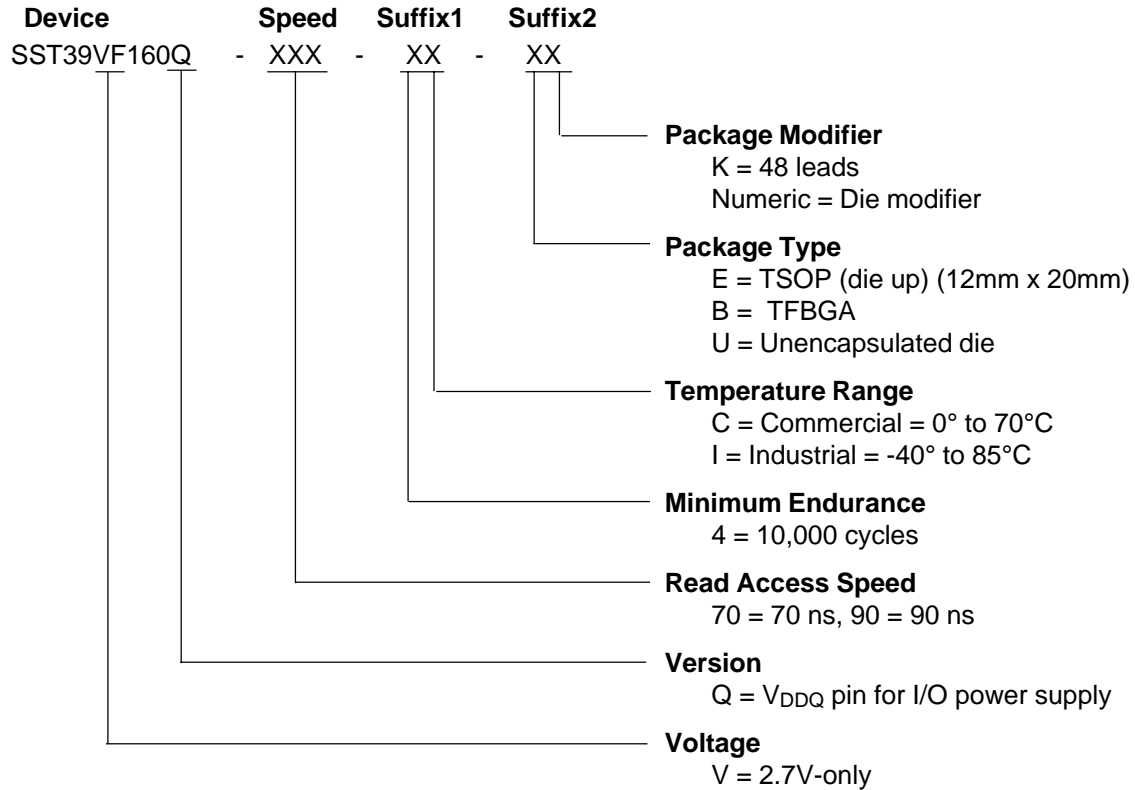

FIGURE 19: ERASE COMMAND SEQUENCE



# 16 Megabit Multi-Purpose Flash SST39VF160Q / SST39VF160

Advance Information



### SST39VF160Q Valid combinations

SST39VF160Q-70-4C-EK	SST39VF160Q-70-4C-BK	
SST39VF160Q-90-4C-EK	SST39VF160Q-90-4C-BK	SST39VF160Q-90-4C-U1
SST39VF160Q-70-4I-EK	SST39VF160Q-70-4I-BK	
SST39VF160Q-90-4I-EK	SST39VF160Q-90-4I-BK	

### SST39VF160 Valid combinations

SST39VF160-70-4C-EK	SST39VF160-70-4C-BK	
SST39VF160-90-4C-EK	SST39VF160-90-4C-BK	SST39VF160-90-4C-U1
SST39VF160-70-4I-EK	SST39VF160-70-4I-BK	
SST39VF160-90-4I-EK	SST39VF160-90-4I-BK	

**Example :** Valid combinations are those products in mass production or will be in mass production. Consult your SST sales representative to confirm availability of valid combinations and to determine availability of new combinations.



# 16 Megabit Multi-Purpose Flash SST39VF160Q / SST39VF160

Advance Information

## PACKAGING DIAGRAMS

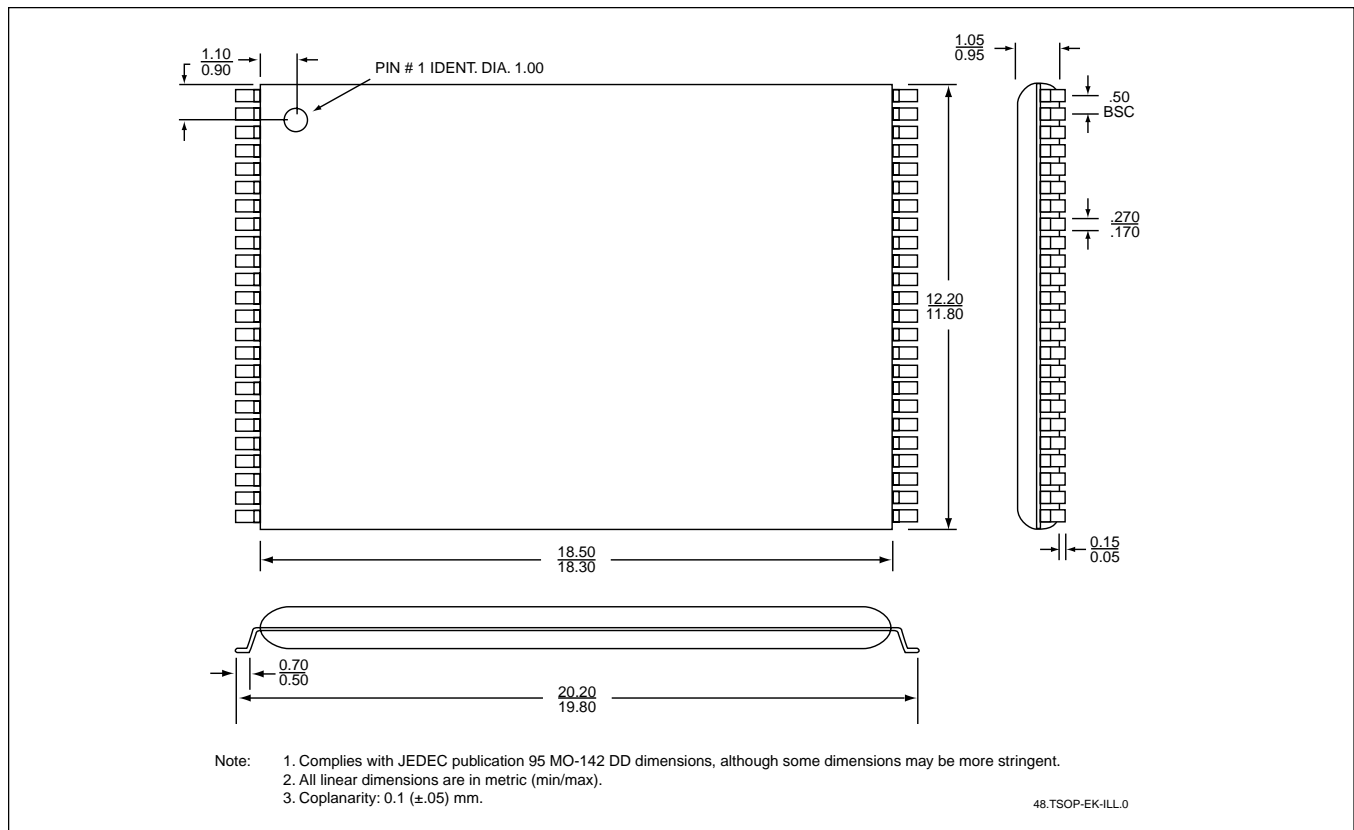

### 48-LEAD THIN SMALL OUTLINE PACKAGE (TSOP)

SST PACKAGE CODE: EK

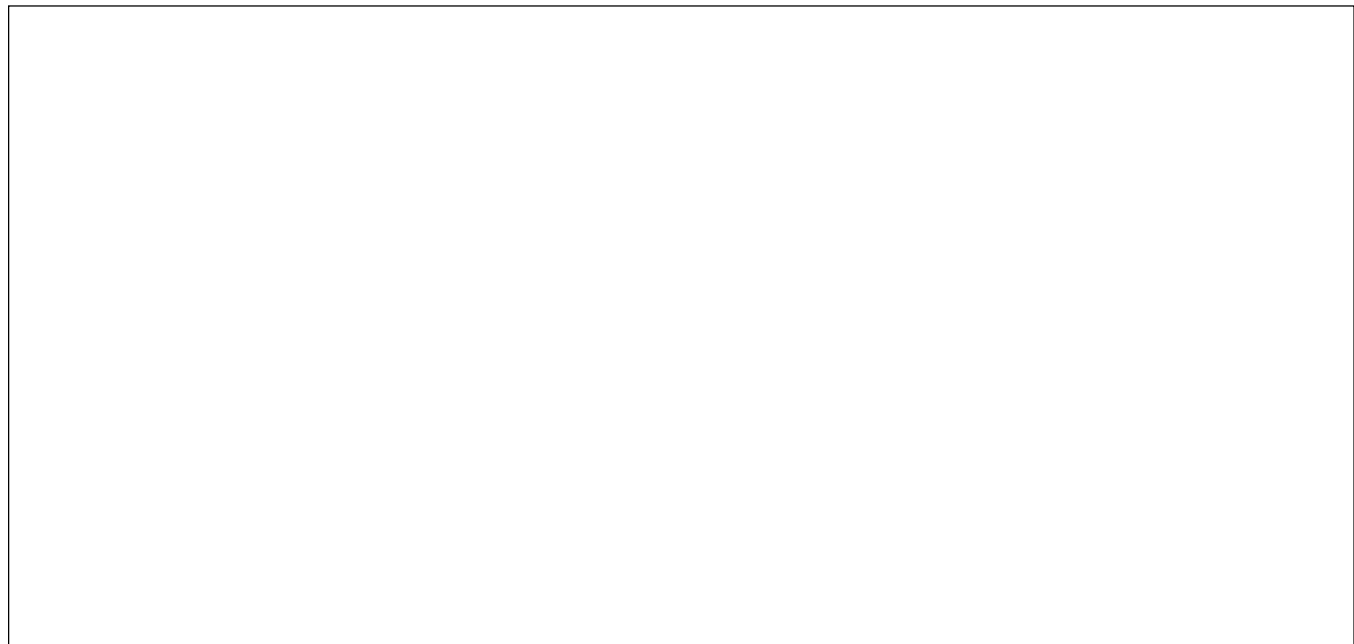

### 6 x 8 BALL PACKAGE (TFBGA)

SST PACKAGE CODE: BK