

DATA SHEET

TEA1098

Speech and handsfree IC

Product specification
Supersedes data of 2000 Sep 26
File under Integrated Circuits, IC03

2001 Aug 24

Speech and handsfree IC

TEA1098

FEATURES

Line interface

- Low DC line voltage
- Voltage regulator with adjustable DC voltage
- Symmetrical high impedance inputs (70 k Ω) for dynamic, magnetic or electret microphones
- DTMF input with confidence tone on earphone and/or loudspeaker
- Receive amplifier for dynamic, magnetic or piezo-electric earpieces (with externally adjustable gain)
- Automatic Gain Control (AGC) for true line loss compensation.
- Dynamic limiter on loudspeaker amplifier to prevent distortion
- Logarithmic volume control on loudspeaker amplifier via linear potentiometer
- Duplex controller consisting of:
 - Signal and noise envelope monitors for both channels (with adjustable sensitivities and timing)
 - Decision logic (with adjustable switch-over and Idle mode timing)
 - Voice switch control (with adjustable switching range and constant sum of gain during switching).

Supplies

- Provides a strong 3.35 V regulated supply for microcontrollers or diallers
- Provides filtered power supply, optimized according to line current
- Filtered 2.0 V power supply output for electret microphone
- $\overline{\text{PD}}$ logic input for power-down.

Handsfree

- Asymmetrical high input impedance for electret microphone
- Loudspeaker amplifier with single-ended rail-to-rail output and externally adjustable gain

APPLICATIONS

- Line powered telephone sets.

GENERAL DESCRIPTION

The TEA1098 is an analog bipolar circuit dedicated to telephony applications. It includes a line interface, handset (HS) microphone and earpiece amplifiers, handsfree (HF) microphone and loudspeaker amplifiers and a duplex controller with signal and noise monitors on both channels.

This IC provides a 3.35 V supply for a microcontroller or dialler and a 2.0 V filtered voltage supply for an electret microphone.

ORDERING INFORMATION

TYPE NUMBER	PACKAGE		
	NAME	DESCRIPTION	VERSION
TEA1098TV	VSO40	plastic very small outline package; 40 leads	SOT158-1
TEA1098UH	–	bare die; on foil	–

Speech and handsfree IC

TEA1098

QUICK REFERENCE DATA

$I_{line} = 15 \text{ mA}$; $R_{SLPE} = 20 \ \Omega$; $Z_{line} = 600 \ \Omega$; $f = 1 \text{ kHz}$; $T_{amb} = 25 \text{ }^\circ\text{C}$ for TEA1098TV; $T_j = 25 \text{ }^\circ\text{C}$ for TEA1098UH; pin AGC connected to pin LN; $\overline{PD} = \text{HIGH}$; $\text{HFC} = \text{LOW}$; $\text{MUTE} = \text{HIGH}$; measured according to test circuit; unless otherwise specified.

SYMBOL	PARAMETER	CONDITIONS	MIN.	TYP.	MAX.	UNIT
I_{line}	line current operating range	normal operation	11	–	130	mA
		with reduced performance	1	–	11	mA
V_{SLPE}	stabilized voltage between pins SLPE and GND	$I_{line} = 15 \text{ mA}$	3.4	3.7	4.0	V
		$I_{line} = 70 \text{ mA}$	5.7	6.1	6.5	V
V_{BB}	regulated supply voltage for internal circuitry	$I_{line} = 15 \text{ mA}$	2.75	3.0	3.25	V
		$I_{line} = 70 \text{ mA}$	4.9	5.3	5.7	V
V_{DD}	regulated supply voltage on pin V_{DD}	$V_{BB} > 3.35 \text{ V} + 0.25 \text{ V (typ.)}$	3.1	3.35	3.6	V
		otherwise	–	$V_{BB} - 0.25$	–	V
I_{BB}	current available on pin V_{BB}	in speech mode	–	11	–	mA
		in handsfree mode	–	9	–	mA
$I_{BB(pd)}$	current consumption on V_{BB} during power-down phase	$\overline{PD} = \text{LOW}$	–	460	–	μA
$G_{V(\text{MIC-LN})}$	voltage gain from pins MIC+/MIC– to LN	$V_{\text{MIC}} = 5 \text{ mV (RMS)}$	43.3	44.3	45.3	dB
$G_{V(\text{IR-RECO})}$	voltage gain from pin IR (referenced to LN) to RECO	$V_{\text{IR}} = 8 \text{ mV (RMS)}$	28.7	29.7	30.7	dB
$\Delta G_{V(\text{QR})}$	gain voltage range between pins RECO and QR		–3	–	+15	dB
$G_{V(\text{TXIN-TXOUT})}$	voltage gain from pin TXIN to TXOUT	$V_{\text{TXIN}} = 3 \text{ mV (RMS)}$; $R_{\text{GATX}} = 30.1 \text{ k}\Omega$	12.7	15.2	17.7	dB
$G_{V(\text{HFTX-LN})}$	voltage gain from pin HFTX to LN	$V_{\text{HFTX}} = 15 \text{ mV (RMS)}$	33.5	34.7	35.9	dB
$G_{V(\text{HFRX-LSAO})}$	voltage gain from pin HFRX to LSAO	$V_{\text{HFRX}} = 30 \text{ mV (RMS)}$; $R_{\text{GALS}} = 255 \text{ k}\Omega$; $I_{line} = 70 \text{ mA}$	25.5	28	30.5	dB
SWRA	switching range		–	40	–	dB
ΔSWRA	switching range adjustment	$R_{\text{SWR}} = 365 \text{ k}\Omega$	–40	–	+12	dB
$\Delta G_{V(\text{trx})}$	gain control range for transmit and receive amplifiers affected by the AGC; with respect to $I_{line} = 15 \text{ mA}$	$I_{line} = 70 \text{ mA}$	5.45	6.45	7.45	dB

Speech and handsfree IC

TEA1098

BLOCK DIAGRAM

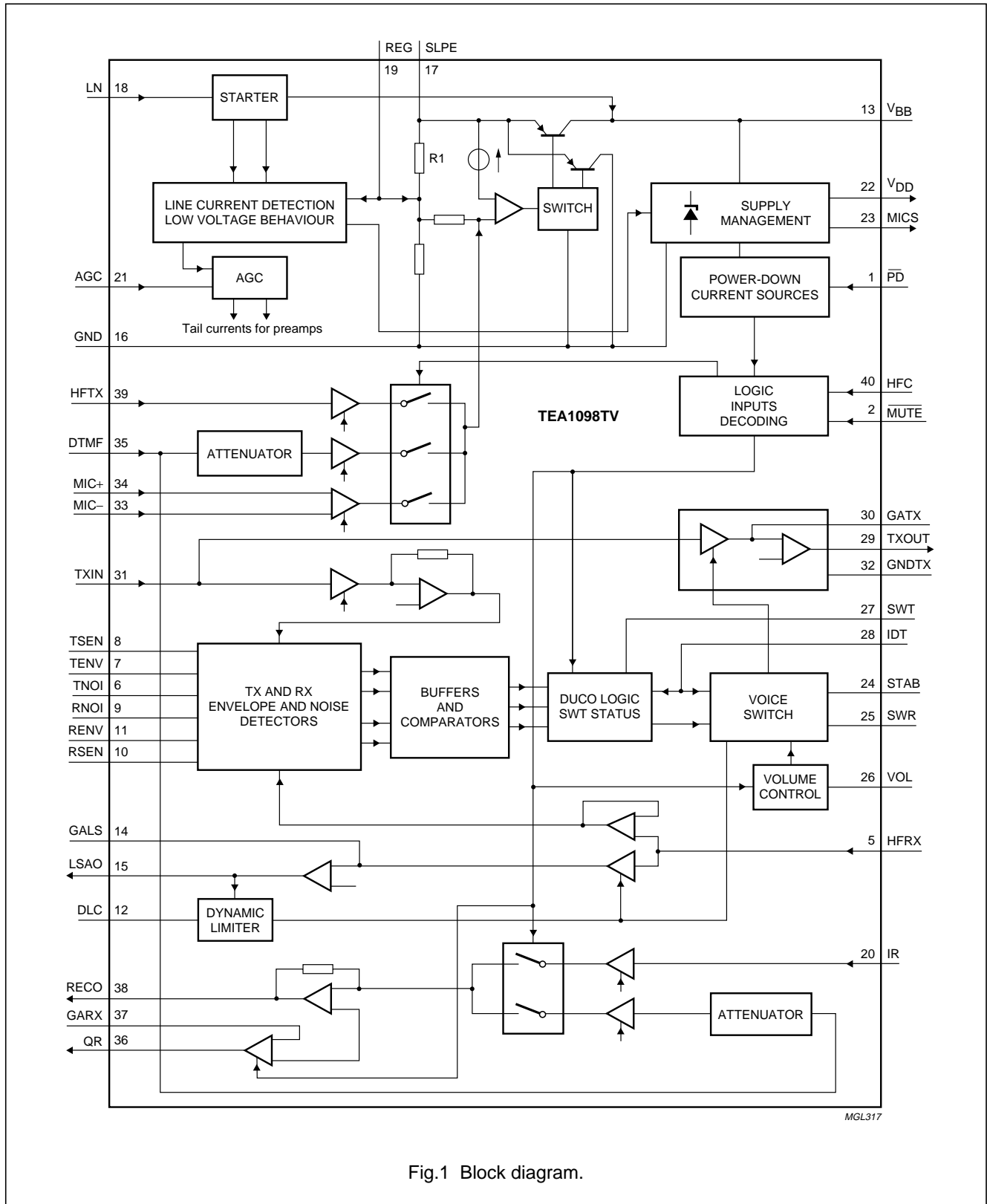

Fig.1 Block diagram.

Speech and handsfree IC

TEA1098

PINNING

SYMBOL	PIN	PAD	DESCRIPTION
	TEA1098TV	TEA1098UH	
$\overline{\text{PD}}$	1	40	power-down input (active LOW)
$\overline{\text{MUTE}}$	2	41	logic input (active LOW)
n.c.	3	42	not connected
n.c.	4	43	not connected
n.c.	–	44	not connected
HFRX	5	1	receive input for loudspeaker amplifier
TNOI	6	2	transmit noise envelope timing adjustment
TENV	7	3	transmit signal envelope timing adjustment
TSEN	8	4	transmit signal envelope sensitivity adjustment
RNOI	9	5	receive noise envelope timing adjustment
RSEN	10	6	receive signal envelope sensitivity adjustment
RENV	11	7	receive signal envelope timing adjustment
DLC	12	8	dynamic limiter capacitor for the loudspeaker amplifier
V_{BB}	13	9	stabilized supply for internal circuitry
GALS	14	10	loudspeaker amplifier gain adjustment
LSAO	15	11	loudspeaker amplifier output
n.c.	–	12	not connected
GND	16	13	ground reference
SLPE	17	14 and 15	line current sense
LN	18	16	positive line terminal input
REG	19	17	line voltage regulator decoupling
IR	20	18	receive amplifier input
AGC	21	19	automatic gain control or line loss compensation input
V_{DD}	22	20	3.35 V regulated voltage supply for microcontrollers
MICS	23	21	microphone supply
STAB	24	22	reference current adjustment
SWR	25	23	switching range adjustment
VOL	26	24	loudspeaker volume adjustment
SWT	27	25	switch-over timing adjustment
IDT	28	26	Idle mode timing adjustment
TXOUT	29	27	HF microphone amplifier output
GATX	30	28	HF microphone amplifier gain adjustment
TXIN	31	29	HF microphone amplifier input
GNDTX	32	30 and 31	ground reference for microphone amplifiers
MIC–	33	32	negative handset microphone amplifier input
MIC+	34	33	positive handset microphone amplifier input
DTMF	35	34	dual tone multi-frequency input
QR	36	35	earpiece amplifier output

Speech and handsfree IC

TEA1098

SYMBOL	PIN	PAD	DESCRIPTION
	TEA1098TV	TEA1098UH	
GARX	37	36	earpiece amplifier gain adjustment
RECO	38	37	receive amplifier output
HFTX	39	38	transmit input for line amplifier
HFC	40	39	logic input

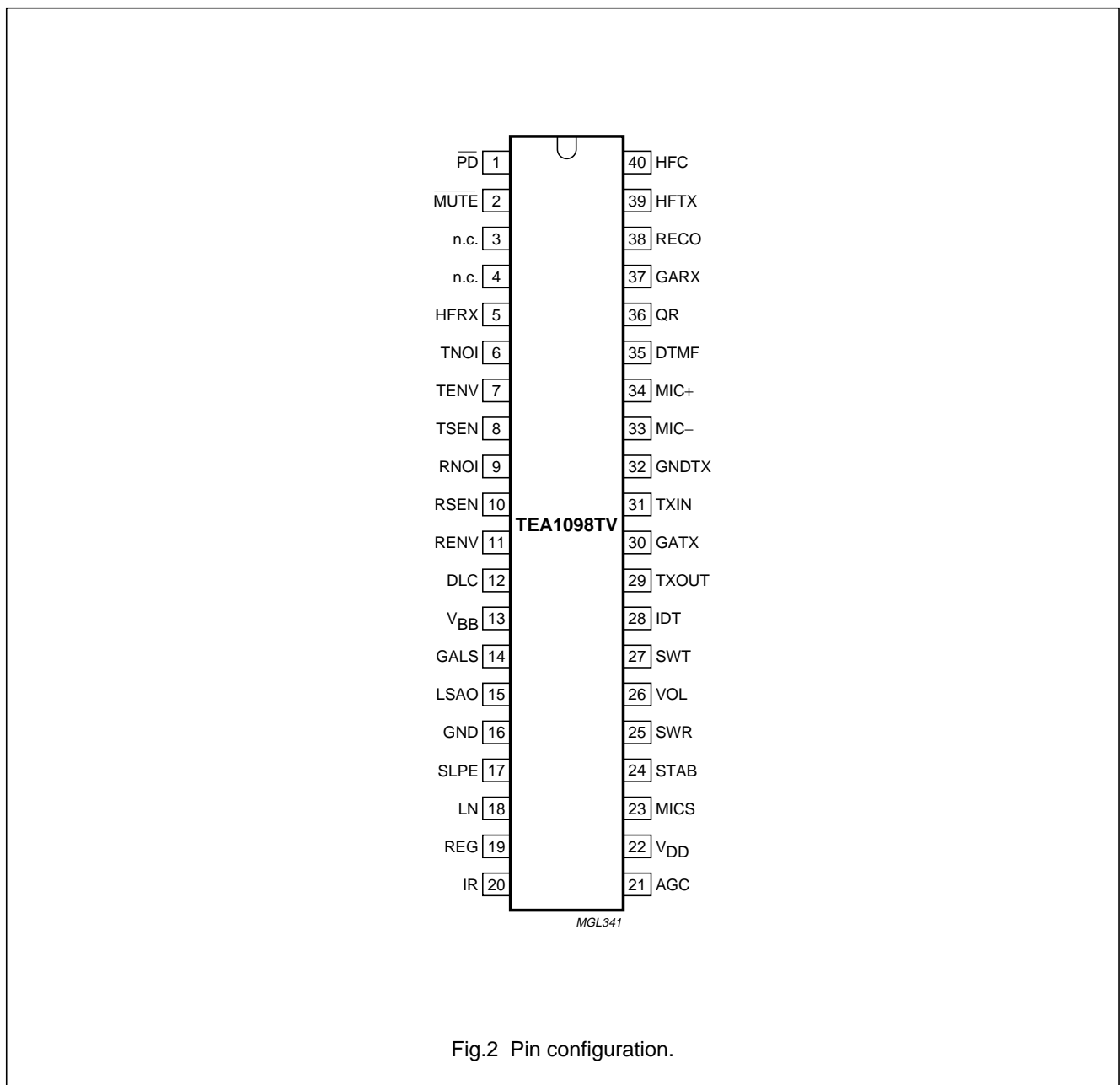

Fig.2 Pin configuration.

Speech and handsfree IC

TEA1098

FUNCTIONAL DESCRIPTION

All data values given in this chapter are typical, except when otherwise specified.

Supplies

LINE INTERFACE AND INTERNAL SUPPLY (PINS LN, SLPE, REG AND V_{BB})

The supply for the TEA1098 and its peripherals is obtained from the line. The IC generates a stabilized reference voltage (V_{ref}) between pins SLPE and GND. This reference voltage is equal to 3.7 V for line currents below 18 mA. When the line current rises above 45 mA, the reference voltage rises linearly to 6.1 V. For line currents below 9 mA, V_{ref} is automatically adjusted to a lower value. The performance of the TEA1098 in this so-called low voltage area is limited (see Section "Low voltage behaviour"). The reference voltage is temperature compensated.

The voltage between pins SLPE and REG is used by the internal regulator to generate the stabilized reference voltage and is decoupled by a capacitor connected between pins LN and REG. This capacitor, converted into an equivalent inductance realizes the set impedance conversion from its DC value (R_{SLPE}) to its AC value (done by an external impedance).

The IC regulates the line voltage at pin LN which can be calculated as follows:

$$V_{LN} = V_{ref} + R_{SLPE} \times I_{SLPE}$$

$$I_{SLPE} = I_{line} - I_{LN}$$

where:

I_{line} = line current

I_{LN} = current consumed on pin LN (approximately a few μ A)

I_{SLPE} = current flowing through the R_{SLPE} resistor.

The preferred value for R_{SLPE} is 20 Ω . Changing this value not only affects the DC characteristics, it also influences the transmit gains to the line, the gain control characteristic, the sidetone level, and the maximum output swing on the line.

Figure 3 shows that the internal circuit is supplied by pin V_{BB} , which combined with the line interface is a strong supply point.

The line current through resistor R_{SLPE} is sunk by the V_{BB} voltage stabilizer, and is suitable for supplying a loudspeaker amplifier or any peripheral IC. V_{BB} is 3.0 V at line currents below 18 mA and rises linearly to 5.3 V when the line current rises above 45 mA. It is temperature compensated.

The current switch (TR1 and TR2) is intended to reduce distortion of large AC line signals. Current I_{SLPE} is supplied to V_{BB} via TR1 when the voltage on pin SLPE is above $V_{BB} + 0.25$ V. When the voltage on pin SLPE is below this value, I_{SLPE} is shunted to GND via TR2.

Voltage V_{ref} can be increased by connecting an external resistor between pins REG and SLPE. For large line currents, this increase can slightly affect some dynamic performances such as maximum signal level on the line at THD = 2%. The external resistor does not affect the voltage on pin V_{BB} ; see Fig.4 for the main DC voltages.

V_{DD} SUPPLY FOR MICROCONTROLLERS (PIN V_{DD})

The voltage on the V_{DD} supply point follows the voltage on V_{BB} with a difference typically of 250 mV, internally limited to 3.35 V. This voltage is temperature compensated. This supply point can provide a current of up to typically 3 mA. Its internal consumption stays low (a few 10 nA) as long as V_{DD} does not exceed 1.5 V (see Fig.5).

An external voltage can be connected to V_{DD} with limited extra consumption on V_{DD} (typically 100 μ A). This voltage source should not be below 3.5 V or above 6 V.

V_{BB} and V_{DD} can supply current to external circuits within the line limits, taking into account the internal current consumption.

Speech and handsfree IC

TEA1098

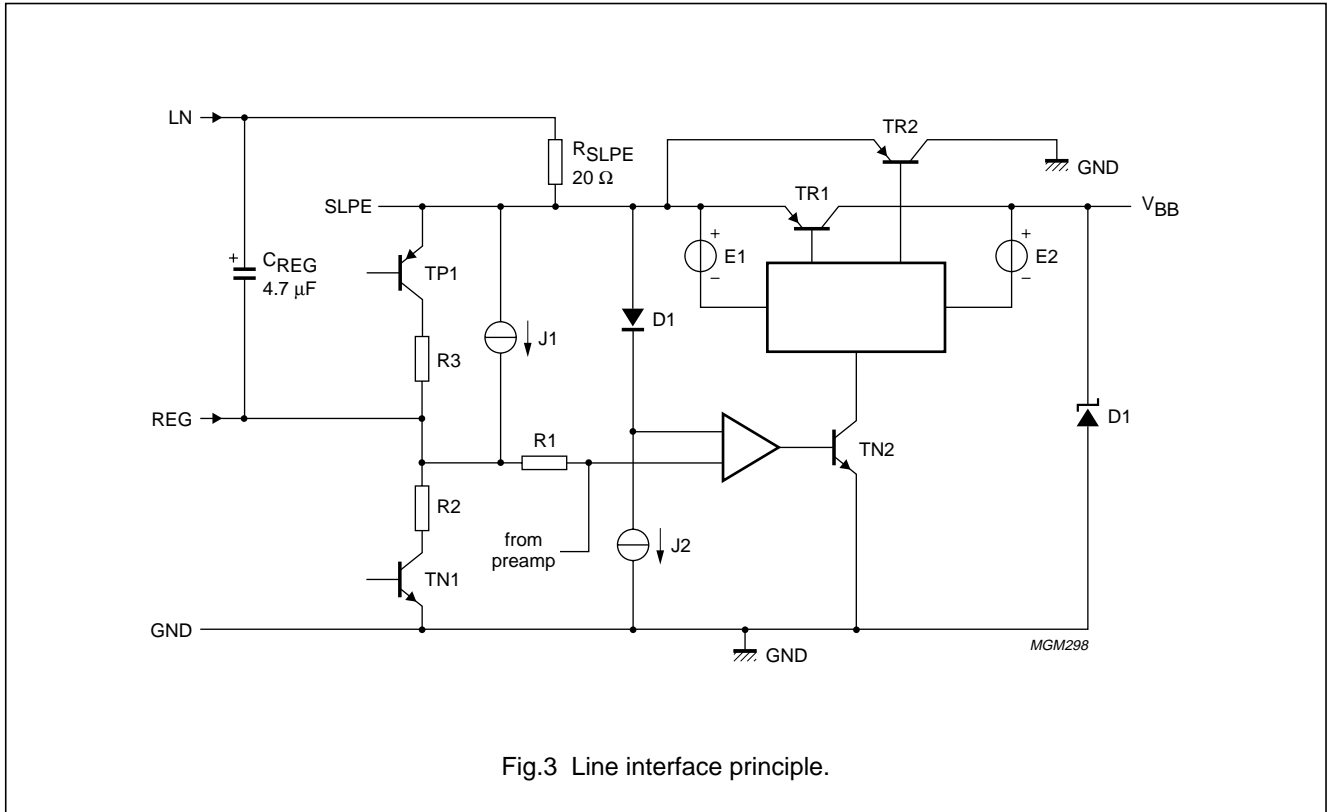

Fig.3 Line interface principle.

SUPPLY FOR MICROPHONE (PINS MICS AND GN DTX)

The MICS output can be used as a supply for an electret microphone. Its voltage is equal to 2.0 V; it can source a current of up to 1 mA and has an output impedance equal to 200 Ω.

LOW VOLTAGE BEHAVIOUR

For line currents below 9 mA, the reference voltage is automatically adjusted to a lower value; the V_{BB} voltage follows the SLPE voltage with a difference of 250 mV. Any excess current available, other than for the purposes of DC biasing the IC, will be small. At low reference voltage, the IC has limited performance.

When voltage V_{BB} falls below 2.7 V, it is detected by the receive dynamic limiter circuit connected to pin LSAO and is continuously activated, discharging the capacitor connected to pin DLC. In the DC condition, the loudspeaker is then automatically disabled below this voltage.

When V_{BB} falls below 2.5 V, the TEA1098 is forced into a low voltage mode irrespective of the logic input levels. This is a speech mode with reduced performance which only enables the microphone channel (between the MIC inputs and pin LN) and the earpiece amplifier. These two channels are able to deliver signals for line currents as small as 3 mA. The HFC input is tied to GND sinking a current of typically 300 μA.

POWER-DOWN MODE (PIN \overline{PD})

To reduce consumption during dialling or register recall (flash), the TEA1098 is provided with a power-down input (pin \overline{PD}). When the voltage on pin \overline{PD} is LOW, the current consumption from V_{BB} and V_{DD} is reduced to typically 460 μA. Therefore a capacitor of 470 μF on V_{BB} is sufficient to power the TEA1098 during pulse dialling or flash. The \overline{PD} input has a pull-up structure. In this mode, the capacitor C_{REG} is internally disconnected.

Speech and handsfree IC

TEA1098

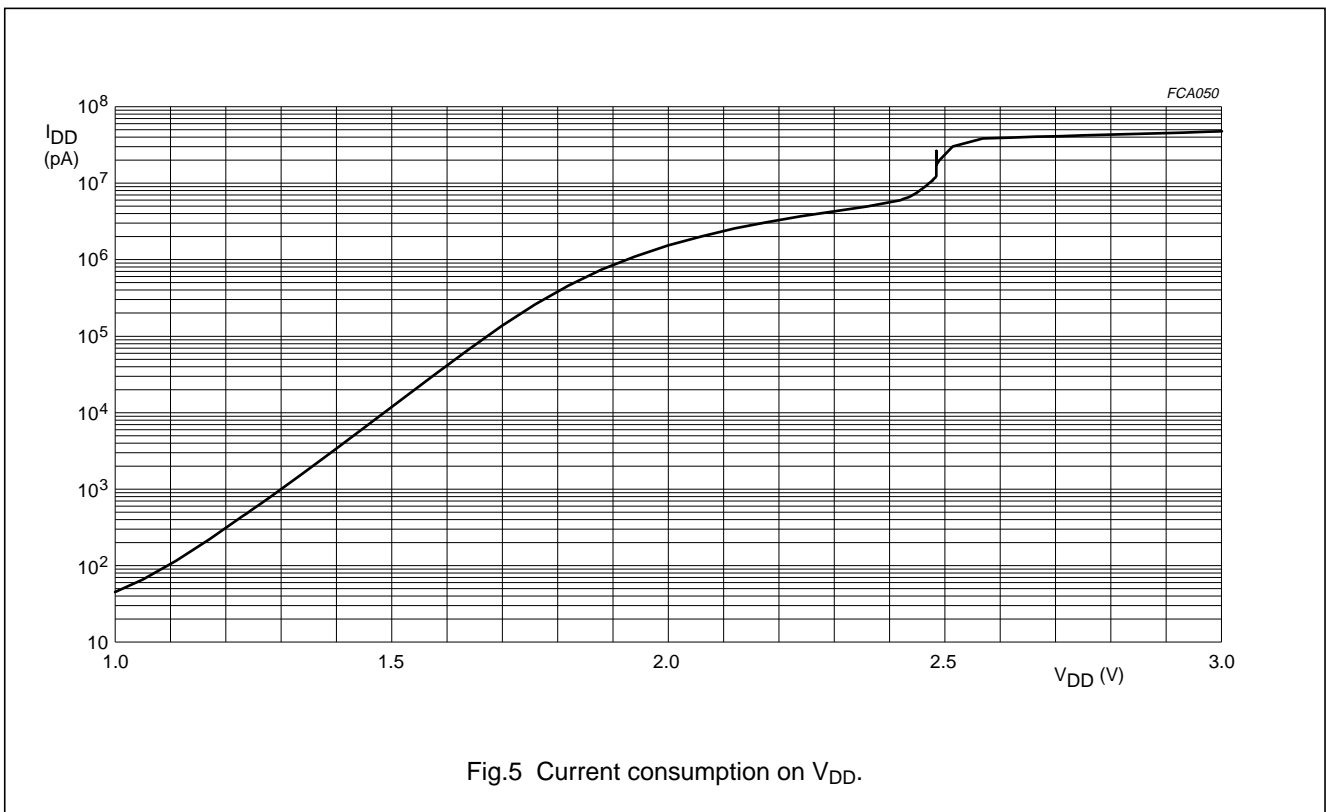
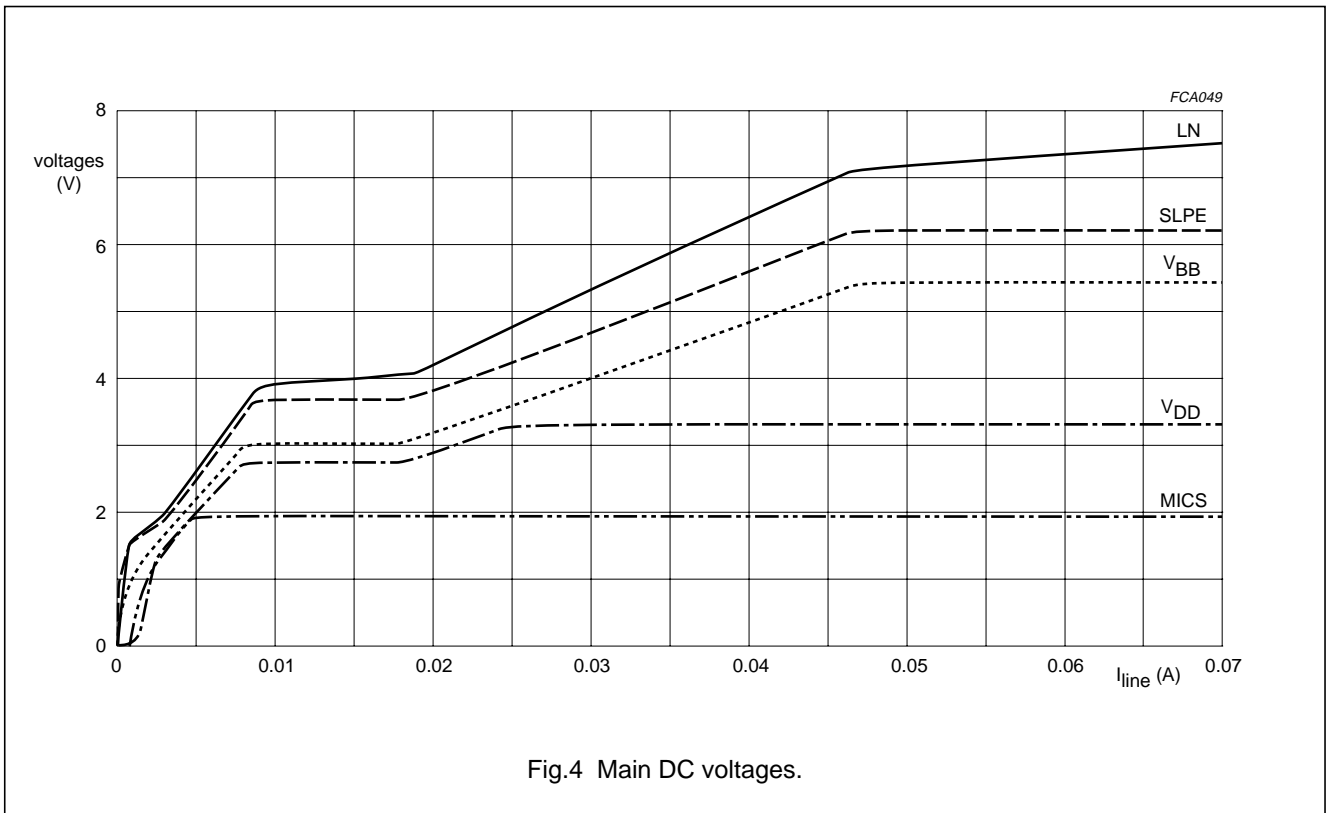

Speech and handsfree IC

TEA1098

Transmit channels (pins MIC+, MIC-, DTMF, HFTX and LN)**HANDSET MICROPHONE AMPLIFIER (PINS MIC+, MIC- AND LN)**

The TEA1098 has symmetrical microphone inputs. The input impedance between pins MIC+ and MIC- is typically 70 k Ω . The voltage gain between pins MIC+/MIC- and LN is set to 44.3 dB. Without output limitation, the microphone input stage can accept signals of up to 18 mV (RMS) at THD = 2% (room temperature). The microphone inputs are biased at a voltage of one diode.

Automatic gain control is provided for line loss compensation.

DTMF AMPLIFIER (PINS DTMF, LN AND RECO)

The TEA1098 has an asymmetrical DTMF input. The input impedance between DTMF and GND is typically 20 k Ω . The voltage gain between pins DTMF and LN is set to 25.35 dB. Without output limitation, the input stage can accept signals of up to 180 mV (RMS) at THD = 2% (room temperature).

When the DTMF amplifier is enabled, dialling tones may be sent on the line. These tones can be heard in the earpiece or in the loudspeaker at a low level. This is called the confidence tone. The voltage attenuation between pins DTMF and RECO is typically -16.5 dB. This input is DC biased at 0 V.

The automatic gain control has no effect on these channels.

HANDSFREE TRANSMIT AMPLIFIER (PINS HFTX AND LN)

The TEA1098 has an asymmetrical HFTX input, which is mainly intended for use in combination with the TXOUT output. The input impedance between HFTX and GND is typically 20 k Ω . The voltage gain between pins HFTX and LN is set to 34.7 dB. Without output limitation, the input stage can accept signals of up to 95 mV (RMS) at THD = 2% (room temperature).

The HFTX input is biased at a voltage of two diodes. Automatic gain control is provided for line loss compensation.

Receive channels (pins IR, RECO, GARX and QR)**RX AMPLIFIER (PINS IR AND RECO)**

The receive amplifier has one input (IR) which is referenced to the line. The input impedance between pins IR and LN is typically 20 k Ω and the DC bias between these pins is equal to the voltage of one diode. The gain between pins IR (referenced to LN) and RECO is typically 29.7 dB. Without output limitation, the input stage can accept signals of up to 50 mV (RMS) at THD = 2% (room temperature).

The receive amplifier has a rail-to-rail output (RECO), which is designed for use with high ohmic (real) loads of more than 5 k Ω . This output is biased at a voltage of two diodes.

Automatic gain control is provided for line loss compensation.

EARPIECE AMPLIFIER (PINS GARX AND QR)

The earpiece amplifier is an operational amplifier which has an output (QR) and an inverting input (GARX). Its input signal is fed by a decoupling capacitor from the receive amplifier output (RECO) to two resistors which set the required gain or attenuation from -3 to +15 dB compared to the receive gain.

Two external capacitors C_{GAR} (connected between GAR and QR) and C_{GARS} (connected between GAR and GND) ensure stability. The C_{GAR} capacitor provides a first-order low-pass filter. The cut-off frequency corresponds to the time constant $C_{GAR} \times R_{e2}$. The relationship $C_{GARS} \geq 10 \times C_{GAR}$ must be satisfied.

The earpiece amplifier has a rail-to-rail output (QR) biased at a voltage of two diodes. It is designed for use with low ohmic (real) loads of 150 Ω , or capacitive loads of 100 nF in series with 100 Ω .

Speech and handsfree IC

TEA1098

AGC (pin AGC)

The TEA1098 performs automatic line loss compensation, which fits well with the true line attenuation. The automatic gain control varies the gain of some transmit and receive amplifiers in accordance with the DC line current. The control range is 6.45 dB for $G_{V(MIC-LN)}$ and $G_{V(IR-RECO)}$, and 6.8 dB for $G_{V(HFTX-LN)}$, which corresponds approximately to a line length of 5.5 km for a 0.5 mm twisted-pair copper cable.

To enable this gain control, pin AGC must be shorted to pin LN. The start current for compensation corresponds to a line current of typically 23 mA and a stop current of 57 mA. The start current can be increased by connecting an external resistor between pins AGC and LN. It can be increased by up to 40 mA (using a resistor of typically 80 kΩ). The start and stop current will be maintained at a ratio of 2.5. By leaving pin AGC open, the gain control is disabled and no line loss compensation occurs.

Handsfree application

Figure 6 shows a loop is formed by the sidetone network in the line interface section, and by the acoustic coupling between loudspeaker and microphone in the handsfree section. A loop-gain of greater than 1 causes howl.

To prevent howl in full duplex applications, the loop-gain must be set much lower than 1. This is achieved by the duplex controller which detects the channel with the 'largest' signal and controls the gains of the microphone and the loudspeaker amplifiers so that the sum of their gains remains constant.

Therefore in the handsfree application, the circuit can have three stable modes:

1. Transmit mode (Tx mode):
The microphone amplifier is at maximum gain, and the loudspeaker amplifier is at minimum gain.
2. Receive mode (Rx mode):
The microphone amplifier is at minimum gain, and the loudspeaker amplifier is at maximum gain.
3. Idle mode:
The microphone amplifier and the loudspeaker amplifier are both midway between maximum and minimum gain.

The difference between the maximum and minimum gain is called the switching range.

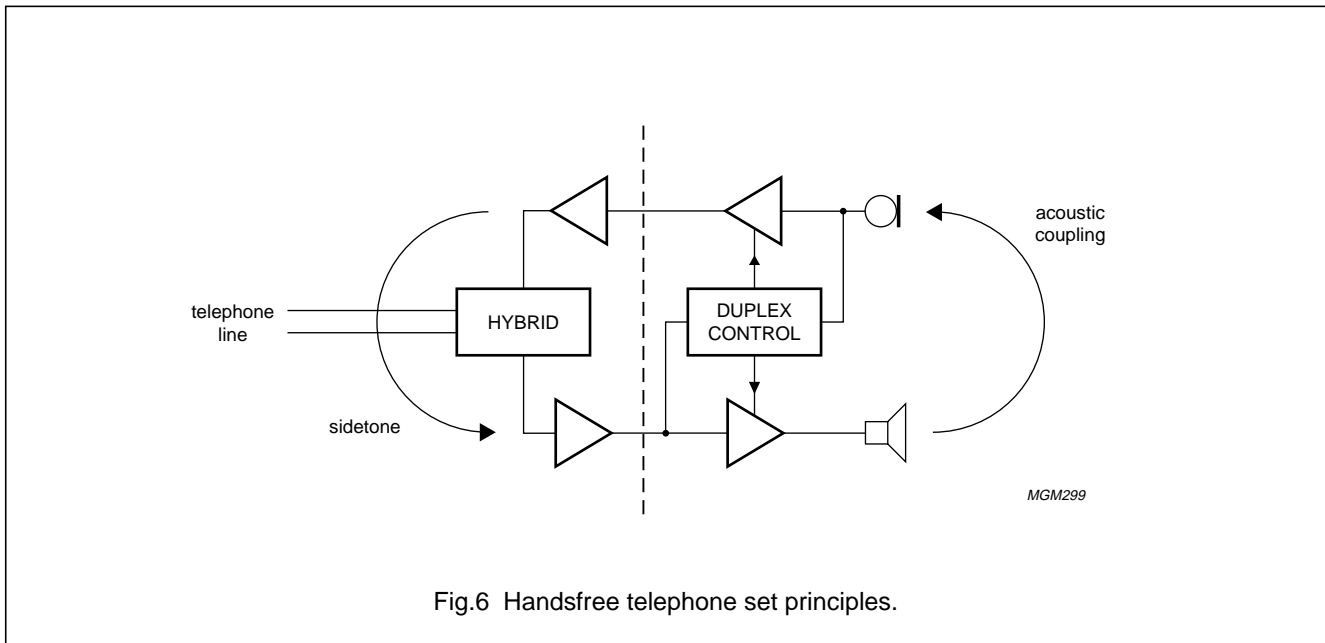

Fig.6 Handsfree telephone set principles.

Speech and handsfree IC

TEA1098

HANDSFREE MICROPHONE CHANNEL (PINS TXIN, GATX, TXOUT AND GNDTX; see Fig.7)

The TEA1098 has an asymmetrical handsfree microphone input (TXIN) with an input resistance of 20 kΩ. The input DC bias is 0 V. The gain of the input stage varies according to the TEA1098 mode. In Tx mode, it has maximum gain; in Rx mode, it has minimum gain, and in Idle mode, it is midway between maximum and minimum gain.

Switch-over from one mode to the other is smooth and click-free. The output (TXOUT) is biased at a voltage of two diodes and has a current capability of 20 μA (RMS). In Tx mode, the overall gain of the microphone amplifier (from pins TXIN to TXOUT) can be adjusted from 0 up to 31 dB to suit specific application requirements. The gain is proportional to the value of R_{GATX} and equals 15.2 dB when R_{GATX} is 30.1 kΩ. Without output limitation, the microphone input stage can accept signals of up to 18 mV (RMS) at THD = 2% (room temperature).

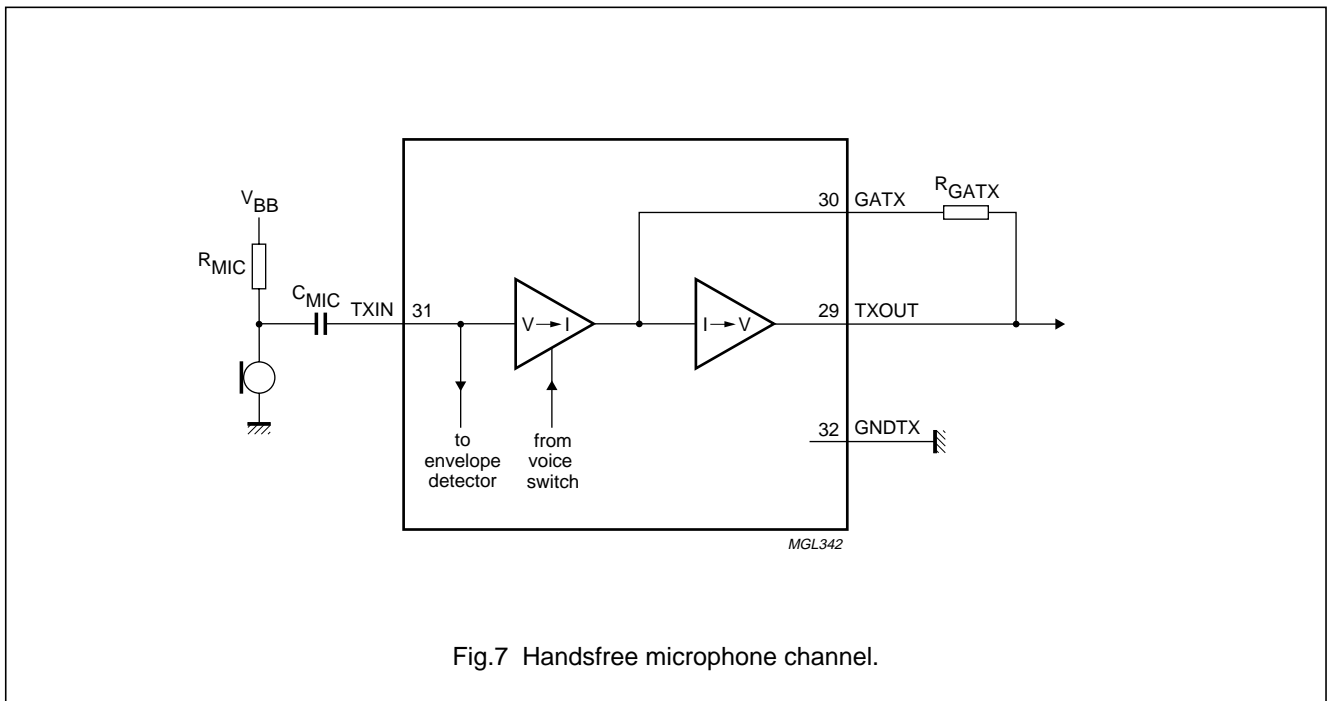

Fig.7 Handsfree microphone channel.

LOUDSPEAKER CHANNEL

Loudspeaker amplifier (pins HFRX, GALS and LSAO)

The TEA1098 loudspeaker amplifier has an asymmetrical input with an input resistance of 20 kΩ between pins HFRX and GND. It is biased at a voltage of two diodes. Without output limitation, the input stage can accept signals of up to 580 mV (RMS) at THD = 2% (room temperature).

The gain of the input stage varies according to the TEA1098 mode. In Rx mode, it has maximum gain; in Tx mode, it has minimum gain and in Idle mode, it is halfway between maximum and minimum gain. Switch-over from one mode to the other is smooth and click-free. The rail-to-rail output stage is designed to power a loudspeaker connected as a single-ended load (between pins LSAO and GND).

In Rx mode, the overall gain of the loudspeaker amplifier can be adjusted from 0 up to 35 dB to suit specific application requirements. The gain from pin HFRX to pin LSAO is proportional to the value of R_{GALS} and is 28 dB when R_{GALS} is 255 kΩ. It is recommended that a capacitor is connected in parallel with R_{GALS} to provide a first-order low-pass filter.

Volume control (pin VOL)

The loudspeaker amplifier gain can be adjusted by the potentiometer R_{VOL}. For logarithmic gain control, a linear potentiometer can be used. Each 1.9 kΩ increase of R_{VOL} results in a gain loss of 3 dB. The maximum gain reduction using the volume control is internally limited to the switching range (see Fig.8).

Speech and handsfree IC

TEA1098

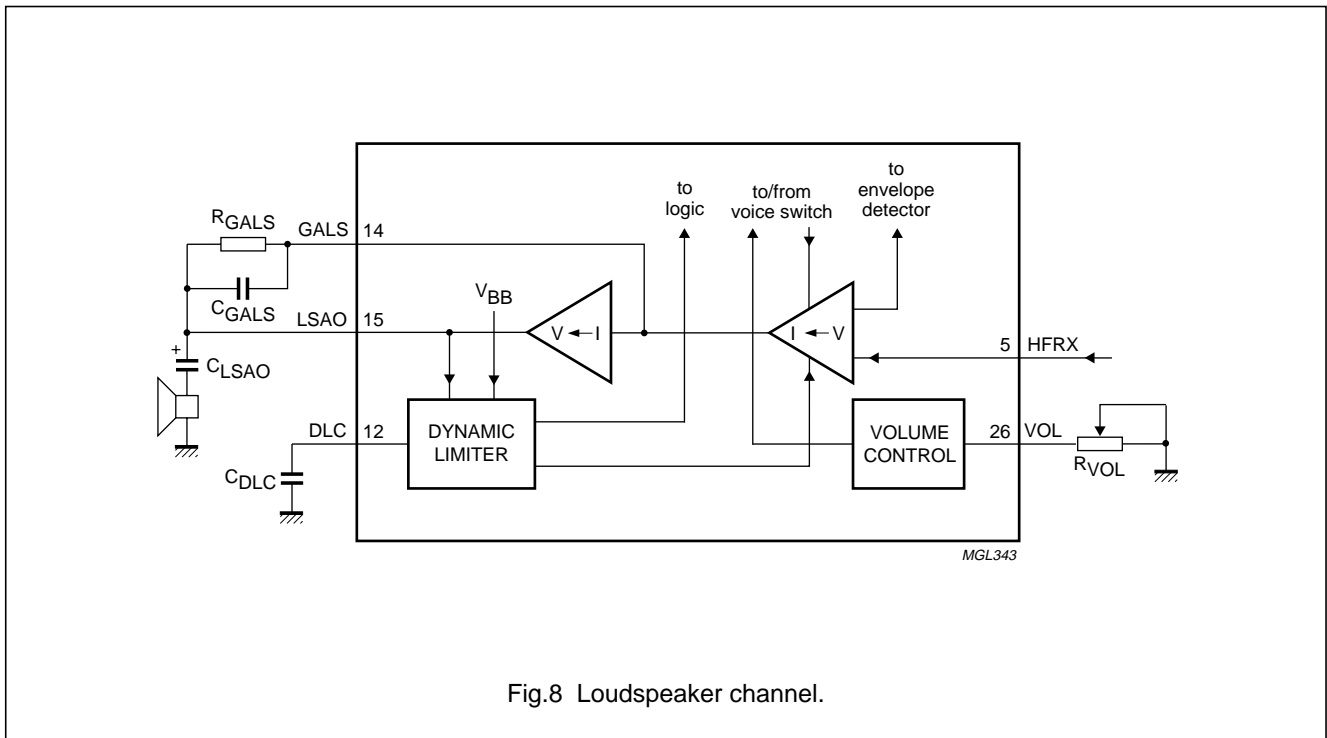

Fig.8 Loudspeaker channel.

Dynamic limiter (pin DLC)

The TEA1098 dynamic limiter prevents clipping of the loudspeaker output stage and protects the operation of the circuit when the supply voltage at V_{BB} falls below 2.7 V.

Hard clipping of the loudspeaker output stage is prevented by rapidly reducing the gain when the output stage starts to saturate. The time taken to effect gain reduction (clipping attack time) is approximately a few milliseconds. The circuit stays in the reduced gain mode until the peaks of the loudspeaker signals no longer cause saturation. The gain of the loudspeaker amplifier then returns to its normal value within the clipping release time (typically 250 ms). Both attack and release times are proportional to the value of the capacitor C_{DLC} .

The total harmonic distortion of the loudspeaker output stage, in reduced gain mode, stays below 2% up to 10 dB (minimum) of input voltage overdrive providing V_{HFRX} is below 580 mV (RMS).

When the supply voltage falls below an internal threshold voltage of 2.7 V, the gain of the loudspeaker amplifier is reduced rapidly (approximately 1 ms). When the supply voltage rises above 2.7 V, the gain of the loudspeaker amplifier is increased. By forcing a level lower than 0.2 V on pin DLC, the loudspeaker amplifier is muted and the TEA1098 is automatically forced into the Tx mode.

DUPLEX CONTROLLER

Signal and noise envelope detectors (pins TSEN, TENV, TNOI, RSEN, RENV and RNOI)

The strength of signal level and background noise in both channels is monitored by signal envelope detectors and noise envelope detectors respectively. The outputs of the envelope detectors provide inputs to the decision logic. The signal and noise envelope detectors are shown in Fig.9.

For the transmit channel, the signal between pin TXIN and pin TSEN is amplified by 40 dB. For the receive channel, the signal between pin HFRX and pin RSEN is amplified by 0 dB.

The signals between pin TSEN and pin TENV, and between pin RSEN and pin RENV are logarithmically compressed and buffered.

The sensitivity of the envelope detectors is set by resistors R_{TSEN} and R_{RSEN} . The capacitors connected in series with these two resistors block any DC component and form a first-order high-pass filter.

In the basic application (see Fig.17) it is assumed that $V_{TXIN} = 1$ mV (RMS) and $V_{HFRX} = 100$ mV (RMS) nominal and R_{TSEN} and R_{RSEN} both have a value of 10 k Ω . When capacitors C_{TSEN} and C_{RSEN} both have a value of 100 nF, the cut-off frequency is at 160 Hz.

Speech and handsfree IC

TEA1098

The buffer amplifiers feeding the compressed signals to pins TENV and RENV have a maximum source current of 120 μA and a maximum sink current of 1 μA . Capacitors C_{TENV} and C_{RENV} set the timing of both signal envelope detectors. In the basic application, the value of both capacitors is 470 nF. Because of the logarithmic compression, each 6 dB signal increase means an 18 mV increase on the signal envelopes at pins TENV or RENV (room temperature). Thus, timings can be expressed in dB/ms. At room temperature, the 120 μA sourced current corresponds to a maximum signal envelope rise-slope of 85 dB/ms, which is sufficient to track normal speech signals. The 1 μA current sunk by pin TENV or pin RENV corresponds to a maximum fall-slope of 0.7 dB/ms. This is sufficient for a smooth envelope and also eliminates the effect of echoes on switching behaviour.

To determine the noise level, the signals between pin TENV and pin TNOI, and between pin RENV and pin RNOI are buffered. The buffers have a maximum source current of 1 μA and a maximum sink current of 120 μA .

Capacitors C_{TNOI} and C_{RNOI} set the timing of both noise envelope detectors. In the basic application (see Fig.17) the value of both capacitors is 4.7 μF .

At room temperature, the 1 μA sourced current corresponds to a maximum noise envelope rise-slope of approximately 0.07 dB/ms which is small enough to track background noise without being affected by speech bursts.

The 120 μA sink current corresponds to a maximum fall-slope of approximately 8.5 dB/ms. However, because the noise envelope tracks the fall of the signal envelope, it will never fall faster than approximately 0.7 dB/ms. The behaviour of the signal envelope and noise envelope detectors is illustrated in Fig.10.

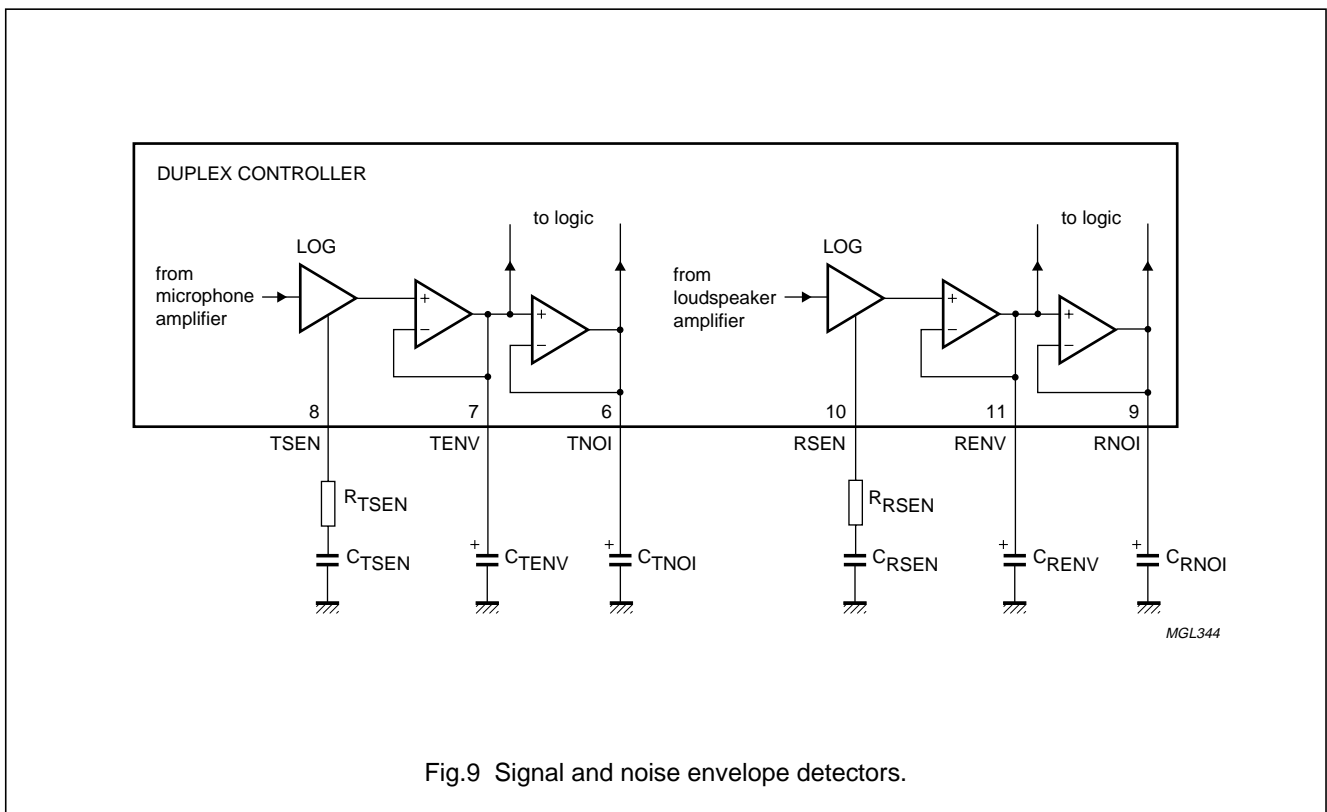

Fig.9 Signal and noise envelope detectors.

Speech and handsfree IC

TEA1098

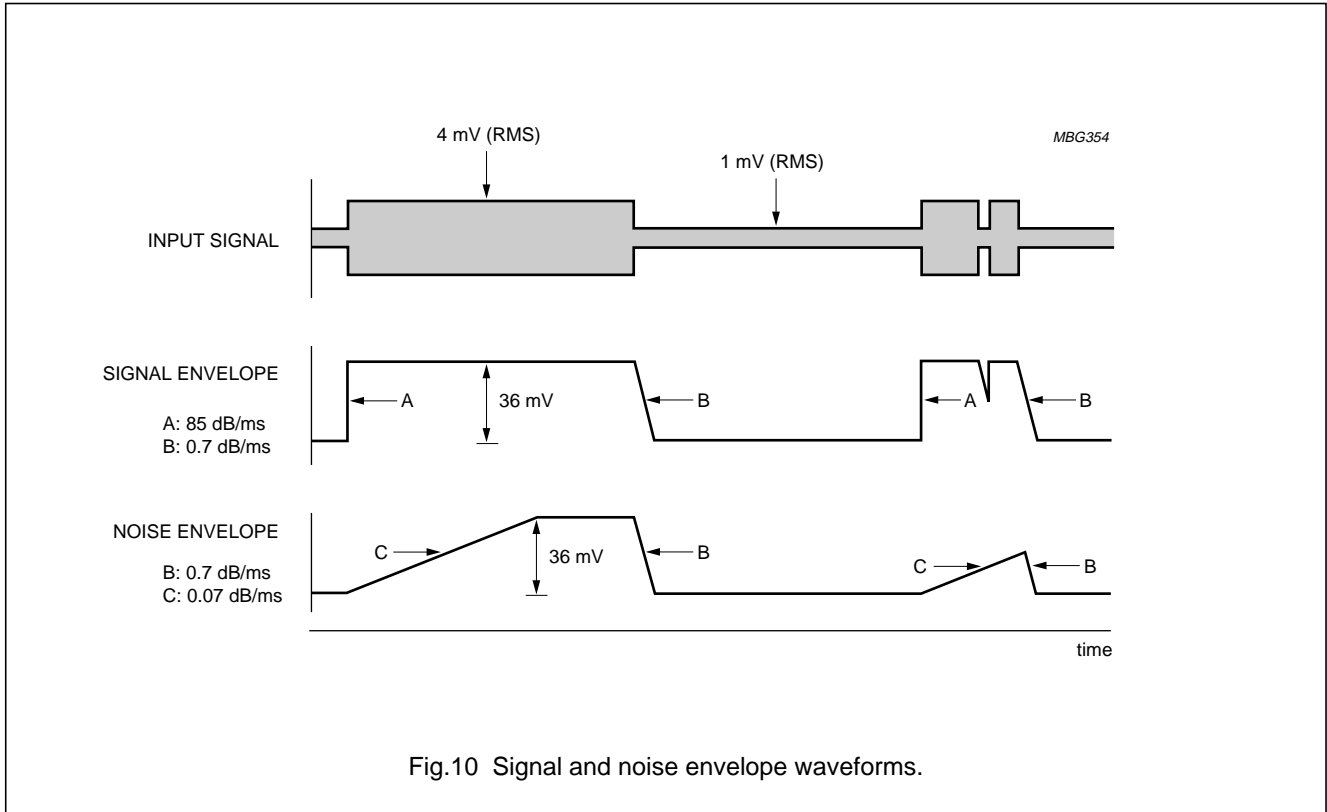

Fig.10 Signal and noise envelope waveforms.

Decision logic (pins IDT and SWT)

The TEA1098 selects its mode of operation (Tx, Rx or Idle) by comparing the signal and noise envelopes of both channels. This is executed by the decision logic. The resulting voltage on pin SWT is the input to the voice switch.

To facilitate the distinction between signal and noise, the signal is considered as speech when its envelope is more than 4.3 dB above the noise envelope. At room temperature, this is equal to a voltage difference of $V_{ENV} - V_{NOI} = 13 \text{ mV}$. This so called speech/noise threshold is implemented in both channels.

The signal on pin TXIN contains both speech and the acoustically coupled signal from the loudspeaker. In Rx mode, the loudspeaker signal overrides the speech. Therefore, the signal envelope on pin TENV consists mainly of the loudspeaker signal. To correct this, an attenuator is connected between pin TENV and the TENV/RENV comparator. Its attenuation is equal to that applied to the microphone amplifier.

When a dial tone is present on the line, without monitoring, it would be recognized as noise because it has a constant amplitude. This would cause the TEA1098 to go into Idle mode, and the user would hear the dial tone fade away.

To prevent this, a dial tone detector monitors input signals between pins HFRX and GND. In standard applications, the detector does not consider a signal level above 25 mV (RMS) to be noise. This level is proportional to the value of R_{RSEN} . Similarly, a transmit detector monitors input signals between pins TXIN and GNDTX. In standard applications the detector does not consider a signal level above 0.75 mV (RMS) to be noise. This level is proportional to the value of R_{TSEN} .

Figure 11 shows that the output of the decision logic is a current source. The logic table shows the relationship between the input levels and the value of the current source. The current source can charge or discharge the capacitor C_{SWT} at a switch-over current of $10 \mu\text{A}$. If the current is zero, the voltage on pin SWT becomes equal to the voltage on pin IDT via the high-ohmic resistor R_{IDT} (idling). The resulting voltage difference between pins SWT and IDT can vary between -400 and $+400 \text{ mV}$ and determines the TEA1098 mode (see Table 1).

Speech and handsfree IC

TEA1098

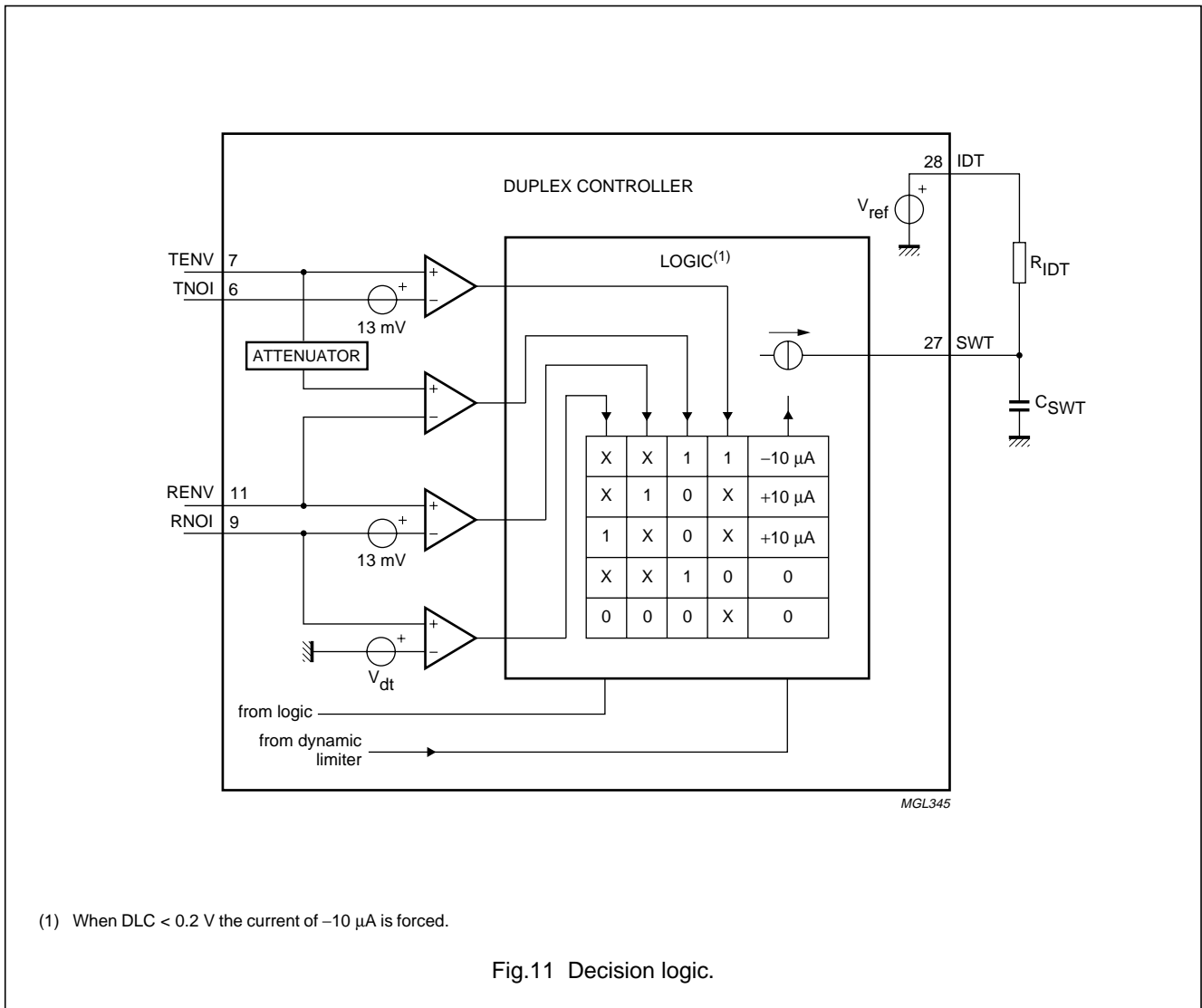

Table 1 TEA1098 modes

V _{SWT} - V _{IDT} (mV)	MODE
<-180	Tx mode
0	Idle mode
>180	Rx mode

The switch-over time, from Rx or Tx mode to Idle mode is equal to $4 \times R_{IDT} \times C_{SWT}$ and is approximately 2 s (Idle mode time).

The DLC input overrides the decision logic. When the voltage on pin DLC falls below 0.2 V, the capacitor C_{SWT} is discharged by 10 μA which selects Tx mode.

The switch-over timing can be set by capacitor C_{SWT} and the Idle mode timing can be set by capacitor C_{SWT} and resistor R_{IDT}. In the basic application given in Fig.17, C_{SWT} is 220 nF and R_{IDT} is 2.2 MΩ. This enables a switch-over time from Tx to Rx mode or vice-versa of approximately 13 ms (580 mV swing on pin SWT). The switch-over time from Idle mode to Tx or Rx mode is approximately 4 ms (180 mV swing on pin SWT).

Speech and handsfree IC

TEA1098

Voice switch (pins STAB and SWR)

Figure 12 is a diagram of the voice switch. With a voltage on pin SWT, the TEA1098 voice switch regulates the gains of the transmit and the receive channels so that the sum of both is held constant.

In Tx mode, the microphone amplifier is at maximum gain and the loudspeaker amplifier is at minimum gain. In Rx mode, their gains are the opposite. In Idle mode, both microphone and loudspeaker amplifiers are midway between maximum and minimum gain.

The difference between the maximum and minimum gain is called the switching range. This range is determined by the ratio of resistors R_{SWR} to R_{STAB} and is adjustable between 0 and 52 dB. Resistor R_{STAB} should be 3.65 k Ω which sets an internally used reference current.

In the basic application diagram (see Fig.17) resistor R_{SWR} is 365 k Ω which results in a switching range of 40 dB. The switch-over behaviour is illustrated in Fig.13.

In Rx mode, the gain of the loudspeaker amplifier can be reduced using the volume control. At the same time, the gain of the microphone amplifier increases, since the voice switch keeps the sum of the gains constant (see dashed curves in Fig.13). However, in Tx mode, the volume control has no effect on the gains of the microphone or loudspeaker amplifiers. Consequently, the switching range is reduced when the volume is reduced. At maximum reduction of volume, the switching range is 0 dB.

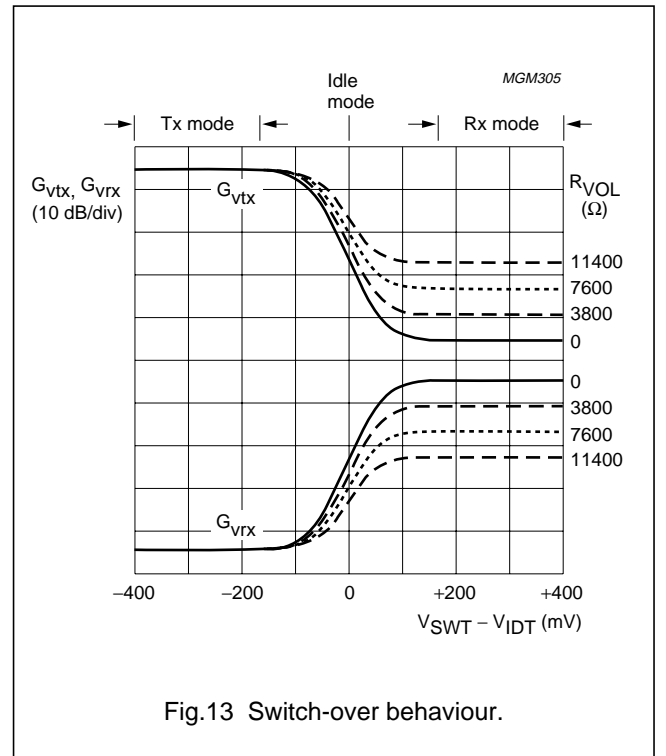
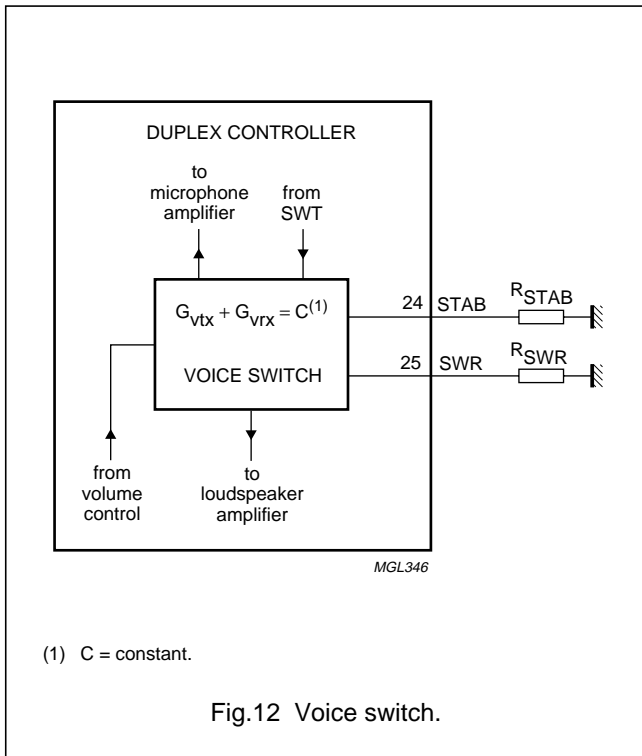

Speech and handsfree IC

TEA1098

Logic inputs

Table 2 Selection of transmit and receive channels for 5 different application modes

LOGIC INPUTS			FEATURES	APPLICATION EXAMPLES
$\overline{\text{PD}}$	HFC	$\overline{\text{MUTE}}$		
0	X	X		flash; DC dialling
1	0	0	DTMF to LN; DTMF to RECO; QR and MICS are active	DTMF dialling in handset mode
1	0	1	MICS to LN; IR to RECO; QR and MICS are active	handset conversation mode
1	1	0	DTMF to LN; DTMF to RECO; HFRX to LSAO; QR and MICS are active	DTMF dialling in handsfree mode
1	1	1	TXIN to TXOUT; HFTX to LN; IR to RECO; HFRX to LSAO; MICS is active	handsfree conversation mode

LIMITING VALUES

In accordance with the Absolute Maximum Rating System (IEC 60134); all DC levels are referenced to GND.

SYMBOL	PARAMETER	CONDITIONS	MIN.	MAX.	UNIT
V_{LN}	positive continuous line voltage		-0.4	+12	V
	repetitive line voltage during switch-on or line interruption		-0.4	+13.2	V
$V_{\text{n(max)}}$	maximum voltage on pins REG, SLPE, IR and AGC		-0.4	$V_{\text{LN}} + 0.4$	V
	maximum voltage on all other pins except V_{DD}		-0.4	$V_{\text{BB}} + 0.4$	V
I_{line}	maximum line current		-	130	mA
P_{tot}	total power dissipation				
	TEA1098TV TEA1098UH	$T_{\text{amb}} = 75\text{ }^{\circ}\text{C}$; see Fig.14 $T_{\text{amb}} = 75\text{ }^{\circ}\text{C}$; note 1	-	400	mW mW
T_{stg}	storage temperature		-40	+125	$^{\circ}\text{C}$
T_{amb}	ambient temperature		-25	+75	$^{\circ}\text{C}$
T_{j}	junction temperature		-	125	$^{\circ}\text{C}$

Note

- Mostly dependent on the maximum required ambient temperature, on the voltage between LN and SLPE and on the thermal resistance between die and ambient temperature. This thermal resistance depends on the application board layout and on the materials used. Figure 15 shows the safe operating area versus this thermal resistance for ambient temperature $T_{\text{amb}} = 75\text{ }^{\circ}\text{C}$.

Speech and handsfree IC

TEA1098

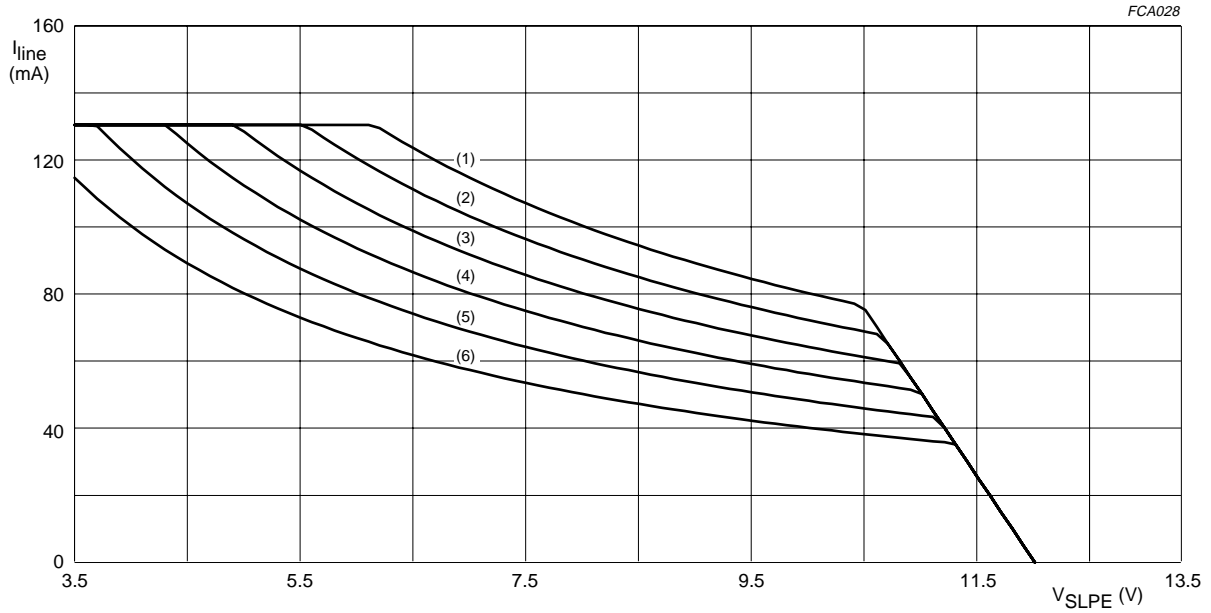

CURVE	T _{amb} (°C)	P _{tot} (mW)
(1)	25	790
(2)	35	710
(3)	45	630
(4)	55	550
(5)	65	470
(6)	75	390

Fig.14 Safe operating area of the TEA1098TV.

Speech and handsfree IC

TEA1098

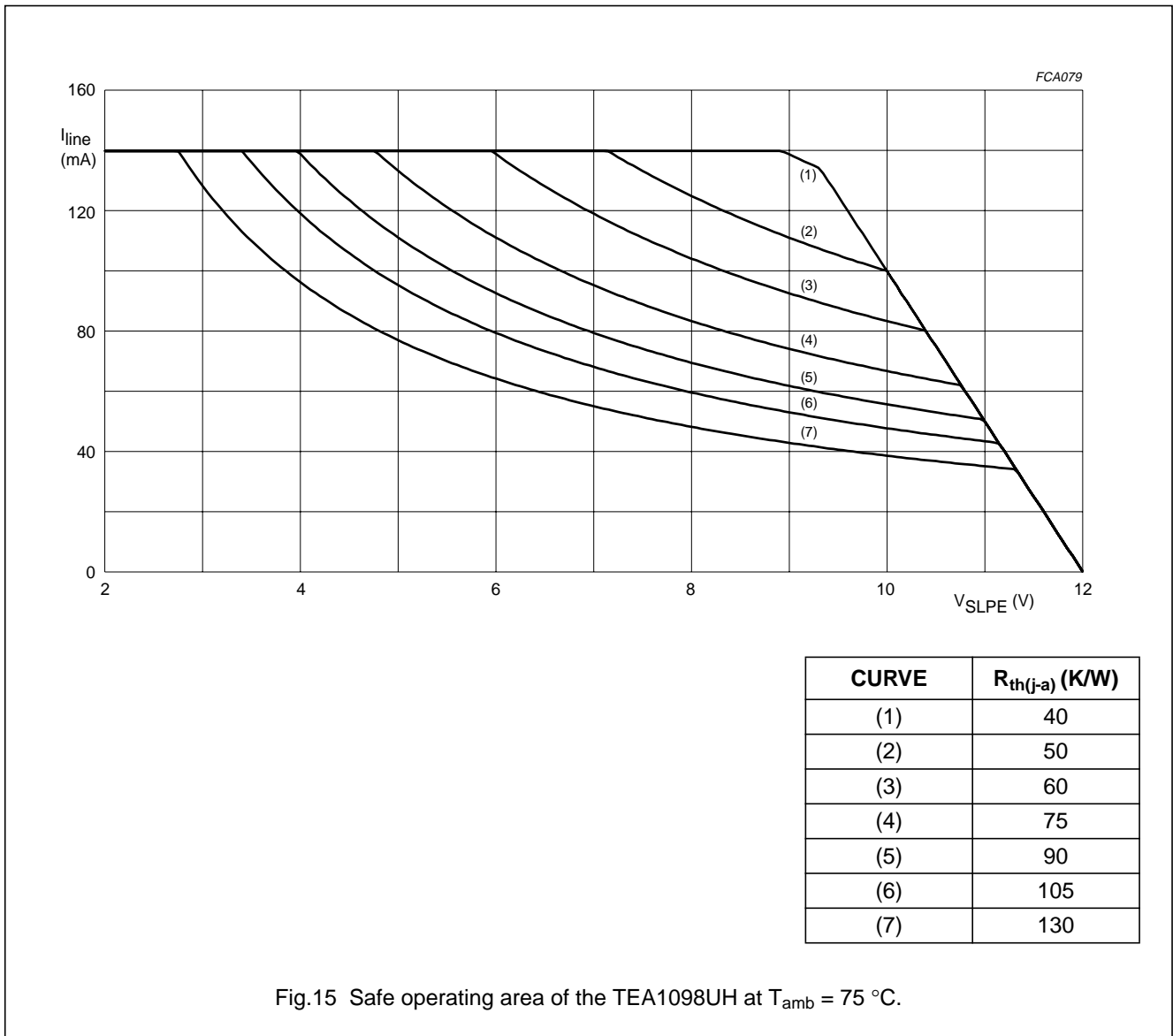

Fig.15 Safe operating area of the TEA1098UH at $T_{amb} = 75\text{ °C}$.

THERMAL CHARACTERISTICS

SYMBOL	PARAMETER	CONDITIONS	VALUE	UNIT
$R_{th(j-a)}$	thermal resistance from junction to ambient			
	TEA1098TV	in free air	117	K/W
	TEA1098UH	note 1	–	K/W

Note

1. The value is to be determined by the customer in the application.

Speech and handsfree IC

TEA1098

CHARACTERISTICS

$I_{line} = 15 \text{ mA}$; $R_{SLPE} = 20 \ \Omega$; $Z_{line} = 600 \ \Omega$; $f = 1 \text{ kHz}$; $T_{amb} = 25 \text{ }^\circ\text{C}$ for TEA1098TV; $T_j = 25 \text{ }^\circ\text{C}$ for TEA1098UH; pin AGC connected to pin LN; $\overline{PD} = \text{HIGH}$; HFC = LOW; MUTE = HIGH; measured according to test circuit; all DC levels are referenced to GND; unless otherwise specified.

SYMBOL	PARAMETER	CONDITIONS	MIN.	TYP.	MAX.	UNIT
Supplies						
LINE INTERFACE AND INTERNAL SUPPLY (PINS LN, SLPE, REG AND V_{BB})						
V_{SLPE}	stabilized voltage between pins SLPE and GND	$I_{line} = 15 \text{ mA}$	3.4	3.7	4	V
		$I_{line} = 70 \text{ mA}$	5.7	6.1	6.5	V
V_{BB}	regulated supply voltage for internal circuitry	$I_{line} = 15 \text{ mA}$	2.75	3.0	3.25	V
		$I_{line} = 70 \text{ mA}$	4.9	5.3	5.7	V
I_{line}	line current for voltage increase	start current	–	18	–	mA
		stop current	–	45	–	mA
$\Delta V_{SLPE(T)}$	stabilized voltage variation with temperature referenced to $25 \text{ }^\circ\text{C}$	$T_{amb} = -25 \text{ to } +75 \text{ }^\circ\text{C}$	–	± 60	–	mV
$\Delta V_{BB(T)}$	regulated voltage variation with temperature referenced to $25 \text{ }^\circ\text{C}$	$T_{amb} = -25 \text{ to } +75 \text{ }^\circ\text{C}$	–	± 30	–	mV
I_{BB}	current available on pin V_{BB}	in speech mode	–	11	–	mA
		in handsfree mode	–	9	–	mA
V_{LN}	line voltage	$I_{line} = 1 \text{ mA}$	–	1.55	–	V
		$I_{line} = 4 \text{ mA}$	–	2.35	–	V
		$I_{line} = 15 \text{ mA}$	3.7	4.0	4.3	V
		$I_{line} = 130 \text{ mA}$	–	8.7	9.5	V
SUPPLY FOR PERIPHERALS (PIN V_{DD})						
V_{DD}	regulated supply voltage on V_{DD}	$V_{BB} > 3.35 \text{ V} + 0.25 \text{ V}$ (typ.)	3.1	3.35	3.6	V
		otherwise	–	$V_{BB} - 0.25$	–	V
$\Delta V_{DD(T)}$	regulated voltage variation with temperature referenced to $25 \text{ }^\circ\text{C}$	$T_{amb} = -25 \text{ to } +75 \text{ }^\circ\text{C}$; $V_{BB} > 3.35 \text{ V} + 0.25 \text{ V}$ (typ.)	–	± 30	–	mV
I_{DD}	current consumption on V_{DD}	in trickle mode; $I_{line} = 0 \text{ mA}$; $V_{DD} = 1.5 \text{ V}$; V_{BB} discharging	–	15	150	nA
		$V_{DD} > 3.35 \text{ V}$	60	100	–	μA
$I_{DD(o)}$	current available for peripherals	$V_{DD} = 3.35 \text{ V}$	–	–3	–	mA
SUPPLY FOR MICROPHONE (PIN MICS)						
V_{MICS}	supply voltage for a microphone		–	2.0	–	V
I_{MICS}	current available on MICS		–	–	–1	mA
POWER-DOWN INPUT (PIN \overline{PD})						
V_{IL}	LOW-level input voltage		–0.4	–	+0.3	V
V_{IH}	HIGH-level input voltage		1.8	–	$V_{BB} + 0.4$	V
I_{PD}	input current		–	–3	–6	μA

Speech and handsfree IC

TEA1098

SYMBOL	PARAMETER	CONDITIONS	MIN.	TYP.	MAX.	UNIT
$I_{BB(PD)}$	current consumption on V_{BB} during power-down	PD = LOW	–	460	–	μA
Preamplifier inputs (pins MIC+, MIC–, IR, DTMF, TXIN, HFTX and HFRX)						
$ Z_{i(MIC)} $	input impedance differential between pins MIC+ and MIC–		–	70	–	$k\Omega$
	input impedance single-ended between pins MIC+/MIC– and GNDTX		–	35	–	$k\Omega$
$ Z_{i(IR)} $	input impedance between pins IR and LN		–	20	–	$k\Omega$
$ Z_{i(DTMF)} $	input impedance between pins DTMF and GND		–	20	–	$k\Omega$
$ Z_{i(TXIN)} $	input impedance between pins TXIN and GNDTX		–	20	–	$k\Omega$
$ Z_{i(HFTX)} $	input impedance between pins HFTX and GND		–	20	–	$k\Omega$
$ Z_{i(HFRX)} $	input impedance between pins HFRX and GND		–	20	–	$k\Omega$
TX amplifiers						
TX HANDSET MICROPHONE AMPLIFIER (PINS MIC+, MIC– AND LN)						
$G_{V(MIC-LN)}$	voltage gain from pins MIC+/MIC– to LN	$V_{MIC} = 5 \text{ mV (RMS)}$	43.3	44.3	45.3	dB
$\Delta G_{V(f)}$	gain variation with frequency referenced to 1 kHz	$f = 300 \text{ to } 3400 \text{ Hz}$	–	± 0.25	–	dB
$\Delta G_{V(T)}$	gain variation with temperature referenced to 25 °C	$T_{amb} = -25 \text{ to } +75 \text{ °C}$	–	± 0.25	–	dB
CMRR	common mode rejection ratio		–	80	–	dB
THD	total harmonic distortion at LN	$V_{LN} = 1.4 \text{ V (RMS)}$	–	–	2	%
		$I_{line} = 4 \text{ mA};$ $V_{LN} = 0.12 \text{ V (RMS)}$	–	–	10	%
$V_{no(LN)}$	noise output voltage at pin LN; pins MIC+/MIC– shorted through 200 Ω	psophometrically weighted (p53 curve)	–	–77.5	–	dBmp
$\Delta G_{V(mute)}$	gain reduction if not activated	see Table 2	60	80	–	dB
DTMF AMPLIFIER (PINS DTMF, LN AND RECO)						
$G_{V(DTMF-LN)}$	voltage gain from pins DTMF to LN	$V_{DTMF} = 50 \text{ mV (RMS)}$	24.35	25.35	26.35	dB
$\Delta G_{V(f)}$	gain variation with frequency referenced to 1 kHz	$f = 300 \text{ to } 3400 \text{ Hz}$	–	± 0.25	–	dB
$\Delta G_{V(T)}$	gain variation with temperature referenced to 25 °C	$T_{amb} = -25 \text{ to } +75 \text{ °C}$	–	± 0.25	–	dB
$\Delta G_{V(mute)}$	gain reduction if not activated	see Table 2	60	80	–	dB

Speech and handsfree IC

TEA1098

SYMBOL	PARAMETER	CONDITIONS	MIN.	TYP.	MAX.	UNIT
$G_{V(\text{DTMF-RECO})}$	voltage gain from pin DTMF to RECO	$V_{\text{DTMF}} = 50 \text{ mV (RMS)}$	–	–16.5	–	dB
TX AMPLIFIER USING HFTX (PINS HFTX AND LN)						
$G_{V(\text{HFTX-LN})}$	voltage gain from pin HFTX to LN	$V_{\text{HFTX}} = 15 \text{ mV (RMS)}$	33.5	34.7	35.9	dB
$\Delta G_{V(f)}$	gain variation with frequency referenced to 1 kHz	$f = 300 \text{ to } 3400 \text{ Hz}$	–	± 0.25	–	dB
$\Delta G_{V(T)}$	gain variation with temperature referenced to 25 °C	$T_{\text{amb}} = -25 \text{ to } +75 \text{ °C}$	–	± 0.25	–	dB
THD	total harmonic distortion at LN	$V_{\text{LN}} = 1.4 \text{ V (RMS)}$	–	–	2	%
$V_{\text{HFTX(rms)}}$	maximum input voltage at HFTX (RMS value)	$I_{\text{line}} = 70 \text{ mA}$; THD = 2%	–	95	–	mV
$V_{\text{no(LN)}}$	noise output voltage at pin LN; pin HFTX shorted to GND through 200 Ω in series with 10 μF	psophometrically weighted (p53 curve)	–	–77.5	–	dBmp
$\Delta G_{V(\text{mute})}$	gain reduction if not activated	see Table 2	60	80	–	dB
RX amplifiers						
RX AMPLIFIERS USING IR (PINS IR AND RECO)						
$G_{V(\text{IR-RECO})}$	voltage gain from pin IR (referenced to LN) to RECO	$V_{\text{IR}} = 8 \text{ mV (RMS)}$	28.7	29.7	30.7	dB
$\Delta G_{V(f)}$	gain variation with frequency referenced to 1 kHz	$f = 300 \text{ to } 3400 \text{ Hz}$	–	± 0.25	–	dB
$\Delta G_{V(T)}$	gain variation with temperature referenced to 25 °C	$T_{\text{amb}} = -25 \text{ to } +75 \text{ °C}$	–	± 0.3	–	dB
$V_{\text{IR(rms)(max)}}$	maximum input voltage on IR (referenced to LN) (RMS value)	$I_{\text{line}} = 70 \text{ mA}$; THD = 2%	–	50	–	mV
$V_{\text{RECO(rms)(max)}}$	maximum output voltage on RECO (RMS value)	THD = 2%	0.75	0.9	–	V
$V_{\text{no(RECO)(rms)}}$	noise output voltage at pin RECO; pin IR is an open-circuit (RMS value)	psophometrically weighted (p53 curve)	–	–88	–	dBVp
$\Delta G_{V(\text{mute})}$	gain reduction if not activated	see Table 2	60	80	–	dB
RX EARPIECE AMPLIFIER (PINS GARX AND QR)						
$\Delta G_{V(\text{RECO-QR})}$	gain voltage range between pins RECO and QR		–3	–	+15	dB
$V_{\text{QR(rms)(max)}}$	maximum output voltage on QR (RMS value)	sine wave drive; $R_{\text{L}} = 150 \Omega$; THD < 2%	0.75	0.9	–	V
$V_{\text{no(QR)(rms)}}$	noise output voltage at pin QR; pin IR is an open-circuit (RMS value)	$G_{V(\text{QR})} = 0 \text{ dB}$; psophometrically weighted (p53 curve)	–	–88	–	dBVp

Speech and handsfree IC

TEA1098

SYMBOL	PARAMETER	CONDITIONS	MIN.	TYP.	MAX.	UNIT
Automatic Gain Control (pin AGC)						
$\Delta G_{V(\text{trx})}$	gain control range for transmit and receive amplifiers affected by the AGC; with respect to $I_{\text{line}} = 15 \text{ mA}$	$I_{\text{line}} = 70 \text{ mA}; G_{V(\text{MIC-LN})}; G_{V(\text{IR-RECO})}$	5.45	6.45	7.45	dB
		$I_{\text{line}} = 70 \text{ mA}$ for $G_{V(\text{HFTX-LN})}$	5.8	6.8	7.8	dB
I_{start}	highest line current for maximum gain		–	23	–	mA
I_{stop}	lowest line current for maximum gain		–	57	–	mA
Logic inputs (pins HFC and MUTE)						
V_{IL}	LOW-level input voltage		–0.4	–	+0.3	V
V_{IH}	HIGH-level input voltage		1.8	–	$V_{\text{BB}} + 0.4$	V
I_{i}	input current	$V_{\text{BB}} = 3.0 \text{ V}$	–	3	6	μA
	for pin HFC		–	–3	–12	μA
Handsfree mode (HFC = HIGH)						
HF MICROPHONE AMPLIFIER (PINS TXIN, TXOUT AND GATX)						
$G_{V(\text{TXIN-TXOUT})}$	voltage gain from pin TXIN to TXOUT	$V_{\text{TXIN}} = 3 \text{ mV (RMS)};$ $R_{\text{GATX}} = 30.1 \text{ k}\Omega$	12.7	15.2	17.7	dB
ΔG_{V}	voltage gain adjustment with R_{GATX}		–15	–	+16	dB
$\Delta G_{\text{V}(f)}$	gain variation with frequency referenced to 1 kHz	$f = 300 \text{ to } 3400 \text{ Hz}$	–	± 0.1	–	dB
$\Delta G_{\text{V}(T)}$	gain variation with temperature referenced to 25 °C	$T_{\text{amb}} = -25 \text{ to } +75 \text{ }^\circ\text{C}$	–	± 0.15	–	dB
$V_{\text{no(TXOUT)(rms)}}$	noise output voltage at pin TXOUT; pin TXIN is shorted through 200 Ω in series with 10 μF to GNDTX (RMS value)	psophometrically weighted (p53 curve)	–	–101	–	dBmp
$\Delta G_{\text{V}(mute)}$	gain reduction if not activated	see Table 2	60	80	–	dB
HF LOUDSPEAKER AMPLIFIER (PINS HFRX, LSAO, GALS AND VOL)						
$G_{V(\text{HFRX-LSAO})}$	voltage gain from pin HFRX to LSAO	$V_{\text{HFRX}} = 30 \text{ mV (RMS)};$ $R_{\text{GALS}} = 255 \text{ k}\Omega;$ $I_{\text{line}} = 70 \text{ mA}$	25.5	28	30.5	dB
ΔG_{V}	voltage gain adjustment with R_{GALS}		–28	–	+7	dB
$\Delta G_{\text{V}(f)}$	gain variation with frequency referenced to 1 kHz	$f = 300 \text{ to } 3400 \text{ Hz}$	–	± 0.3	–	dB
$\Delta G_{\text{V}(T)}$	gain variation with temperature referenced to 25 °C	$T_{\text{amb}} = -25 \text{ to } +75 \text{ }^\circ\text{C}$	–	± 0.3	–	dB
$\Delta G_{\text{V}(vol)}$	voltage gain variation related to $\Delta R_{\text{VOL}} = 1.9 \text{ kW}$	total attenuation does not exceed switching range	–	–3	–	dB

Speech and handsfree IC

TEA1098

SYMBOL	PARAMETER	CONDITIONS	MIN.	TYP.	MAX.	UNIT
$V_{\text{HFRX(rms)(max)}}$	maximum input voltage at pin HFRX (RMS value)	$I_{\text{line}} = 70 \text{ mA}$; $R_{\text{GALS}} = 33 \text{ k}\Omega$; for THD = 2% in the input stage	–	580	–	mV
$V_{\text{no(LSAO)(rms)}}$	noise output voltage at pin LSAO; pin HFRX is open-circuit (RMS value)	psophometrically weighted (p53 curve)	–	–79	–	dBVp
$\Delta G_{\text{V(mute)}}$	gain reduction if not activated	see Table 2	60	80	–	dB
$V_{\text{LSAO(rms)}}$	output voltage (RMS value)	$I_{\text{BB}} = 0 \text{ mA}$; $I_{\text{DD}} = 1 \text{ mA}$ $I_{\text{line}} = 18 \text{ mA}$ $I_{\text{line}} = 30 \text{ mA}$ $I_{\text{line}} > 50 \text{ mA}$	–	0.9 1.3 1.6	–	V V V
$I_{\text{LSAO(max)}}$	maximum output current at pin LSAO (peak value)		150	300	–	mA
DYNAMIC LIMITER (PINS LSAO AND DLC)						
t_{att}	attack time	V_{HFRX} jumps from 20 mV to 20 mV + 10 dB	–	–	5	ms
		V_{BB} jumps below $V_{\text{BB(th)}}$	–	1	–	ms
t_{rel}	release time	V_{HFRX} jumps from 20 mV + 10 dB to 20 mV	–	100	–	ms
THD	total harmonic distortion	$V_{\text{HFRX}} = 20 \text{ mV} + 10 \text{ dB}$; $t > t_{\text{att}}$	–	1	2	%
$V_{\text{BB(th)}}$	V_{BB} limiter threshold		–	2.7	–	V
MUTE RECEIVE (PIN DLC)						
$V_{\text{DLC(th)}}$	threshold voltage required on pin DLC to obtain mute receive condition		–0.4	–	+0.2	V
$I_{\text{DLC(th)}}$	threshold current sourced by pin DLC in mute receive condition	$V_{\text{DLC}} = 0.2 \text{ V}$	–	100	–	μA
$\Delta G_{\text{Vrx(mute)}}$	voltage gain reduction in mute receive condition	$V_{\text{DLC}} = 0.2 \text{ V}$	60	80	–	dB
TX AND RX ENVELOPE AND NOISE DETECTORS (PINS TSEN, TENV, TNOI, RSEN, RENV AND RNOI)						
<i>Preamplifiers</i>						
$G_{\text{V(TSEN)}}$	voltage gain from pin TXIN to TSEN		–	40	–	dB
$G_{\text{V(RSEN)}}$	voltage gain from pin HFRX to RSEN		–	0	–	dB
<i>Logarithmic compressor and sensitivity adjustment</i>						
$\Delta V_{\text{det(TSEN)}}$	sensitivity detection on pin TSEN; voltage change on pin TENV when doubling the current from TSEN	$I_{\text{TSEN}} = 0.8 \text{ to } 160 \mu\text{A}$	–	18	–	mV

Speech and handsfree IC

TEA1098

SYMBOL	PARAMETER	CONDITIONS	MIN.	TYP.	MAX.	UNIT
$\Delta V_{\text{det(RSEN)}}$	sensitivity detection on pin RSEN; voltage change on pin RENV when doubling the current from RSEN	$I_{\text{RSEN}} = 0.8$ to $160 \mu\text{A}$	–	18	–	mV
<i>Signal envelope detectors</i>						
$I_{\text{source(ENV)}}$	maximum current sourced from pin TENV or RENV		–	120	–	μA
$I_{\text{sink(ENV)}}$	maximum current sunk by pin TENV or RENV		–1.25	–1	–0.75	μA
ΔV_{ENV}	voltage difference between pins RENV and TENV	$10 \mu\text{A}$ is sourced from both RSEN and TSEN; signal detectors tracking; note 1	–	± 3	–	mV
<i>Noise envelope detectors</i>						
$I_{\text{source(NOI)}}$	maximum current sourced from pin TNOI or RNOI		0.75	1	1.25	μA
$I_{\text{sink(NOI)}}$	maximum current sunk by pin TNOI or RNOI		–	–120	–	μA
ΔV_{NOI}	voltage difference between pins RNOI and TNOI	$5 \mu\text{A}$ is sourced from both RSEN and TSEN; noise detectors tracking; note 1	–	± 3	–	mV
DIAL TONE DETECTOR						
$V_{\text{HFRX(th)(rms)}}$	threshold level at pin HFRX (RMS value)	$R_{\text{RSEN}} = 10 \text{ k}\Omega$	–	25	–	mV
TX LEVEL LIMITER						
$V_{\text{TXIN(th)(rms)}}$	threshold level at pin TXIN (RMS value)	$R_{\text{TSEN}} = 10 \text{ k}\Omega$	–	0.75	–	mV
DECISION LOGIC (PINS IDT AND SWT)						
<i>Signal recognition</i>						
$\Delta V_{\text{Srx(th)}}$	threshold voltage between pins RENV and RNOI to switch-over from receive to Idle mode	$V_{\text{HFRX}} < V_{\text{HFRX(th)}}$; note 2	–	13	–	mV
$\Delta V_{\text{Stx(th)}}$	threshold voltage between pins TENV and TNOI to switch-over from transmit to Idle mode	$V_{\text{TXIN}} < V_{\text{TXIN(th)}}$; note 2	–	13	–	mV
<i>Switch-over</i>						
$I_{\text{source(SWT)}}$	current sourced from pin SWT when switching to receive mode		7.5	10	12.5	μA
$I_{\text{sink(SWT)}}$	current sunk by pin SWT when switching to transmit mode		–12.5	–10	–7.5	μA
$I_{\text{idle(SWT)}}$	current sourced from pin SWT in Idle mode		–	0	–	μA

Speech and handsfree IC

TEA1098

SYMBOL	PARAMETER	CONDITIONS	MIN.	TYP.	MAX.	UNIT
VOICE SWITCH (PINS STAB AND SWR)						
SWRA	switching range		–	40	–	dB
Δ SWRA	switching range adjustment	$R_{SWR} = 365 \text{ k}\Omega$	–40	–	+12	dB
$ \Delta G_v $	voltage gain variation from transmit or receive mode to Idle mode		–	20	–	dB
G_{tr}	gain tracking ($G_{vtx} + G_{vrx}$) during switching, referenced to Idle mode		–	0.5	–	dB

Notes

1. Corresponds to ± 1 dB tracking.
2. Corresponds to 4.3 dB noise/speech recognition level.

Speech and handsfree IC

TEA1098

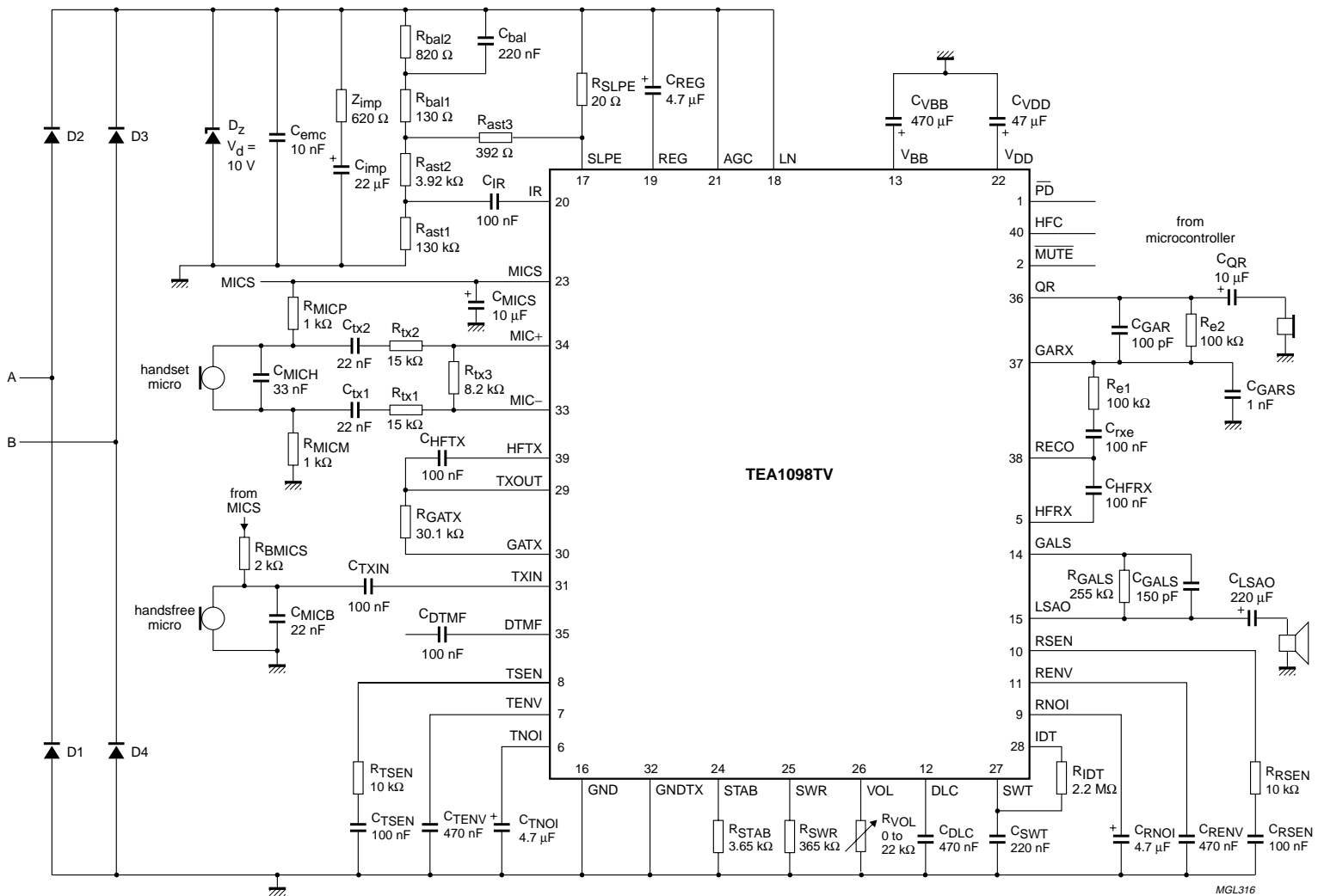

Fig.17 Basic application diagram.

Speech and handsfree IC

TEA1098

BONDING PAD LOCATIONS FOR TEA1098UH

SYMBOL	PAD	COORDINATES ⁽¹⁾	
		x	y
HFRX	1	137.5	3139.2
TNOI	2	137.5	2944.0
TENV	3	137.5	2605.8
TSEN	4	137.5	2375.5
RNOI	5	137.5	2164.5
RSEN	6	137.5	1945.2
RENV	7	137.5	1721.8
DLC	8	137.5	1494.5
V _{BB}	9	137.5	1050.2
GALS	10	137.5	616.8
LSAO	11	185.2	128.0
n.c.	12	401.2	128.0
GND	13	861.5	128.0
SLPE	14	1125.0	128.0
SLPE	15	1348.2	128.0
LN	16	1537.5	128.0
REG	17	1704.8	128.0
IR	18	1888.8	128.0
AGC	19	2084.0	128.0
V _{DD}	20	2251.0	128.2
MICS	21	2508.8	127.0
STAB	22	2703.8	128.5
SWR	23	2897.0	128.0
VOL	24	2944.8	343.0

SYMBOL	PAD	COORDINATES ⁽¹⁾	
		x	y
SWT	25	2944.8	570.0
IDT	26	2945.0	784.0
TXOUT	27	2945.0	973.8
GATX	28	2945.0	1182.0
TXIN	29	2945.0	1390.0
GNDTX	30	2945.0	1581.0
GNDTX	31	2945.0	1747.8
MIC-	32	2945.0	1917.2
MIC+	33	2945.0	2129.0
DTMF	34	2945.0	2931.0
QR	35	2940.0	3136.8
GARX	36	2651.0	3171.2
RECO	37	2451.0	3171.2
HFTX	38	2170.8	3171.2
HFC	39	1934.2	3171.2
PD	40	1678.8	3171.2
MUTE	41	1425.0	3171.2
n.c.	42	1177.0	3171.2
n.c.	43	942.2	3171.2
n.c.	44	738.5	3171.2

Note

- All x/y coordinates (in μm) represent the position of the centre of the pad with respect to the origin ($x/y = 0/0$) of the die (see Fig.18).

Speech and handsfree IC

TEA1098

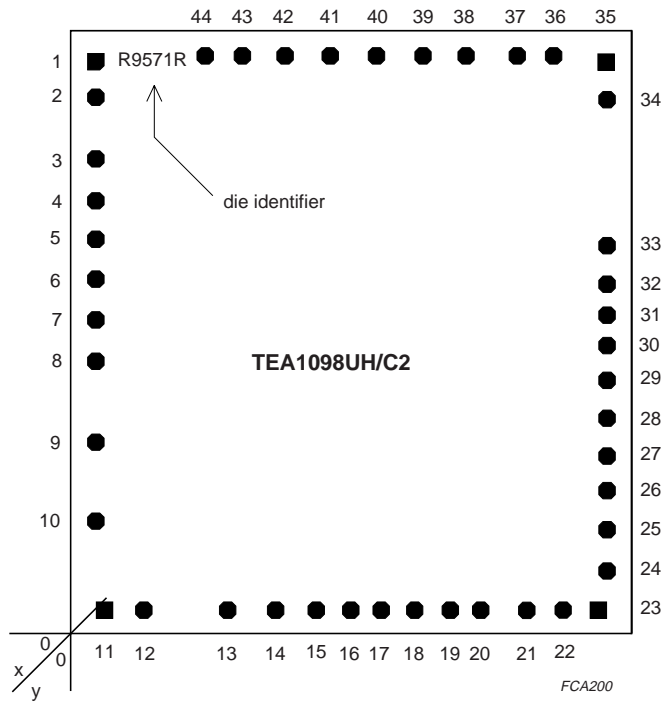

Pad size: 80 μm^2 .

Fig.18 TEA1098UH bonding pad locations.

Speech and handsfree IC

TEA1098

PACKAGE OUTLINE

VSO40: plastic very small outline package; 40 leads

SOT158-1

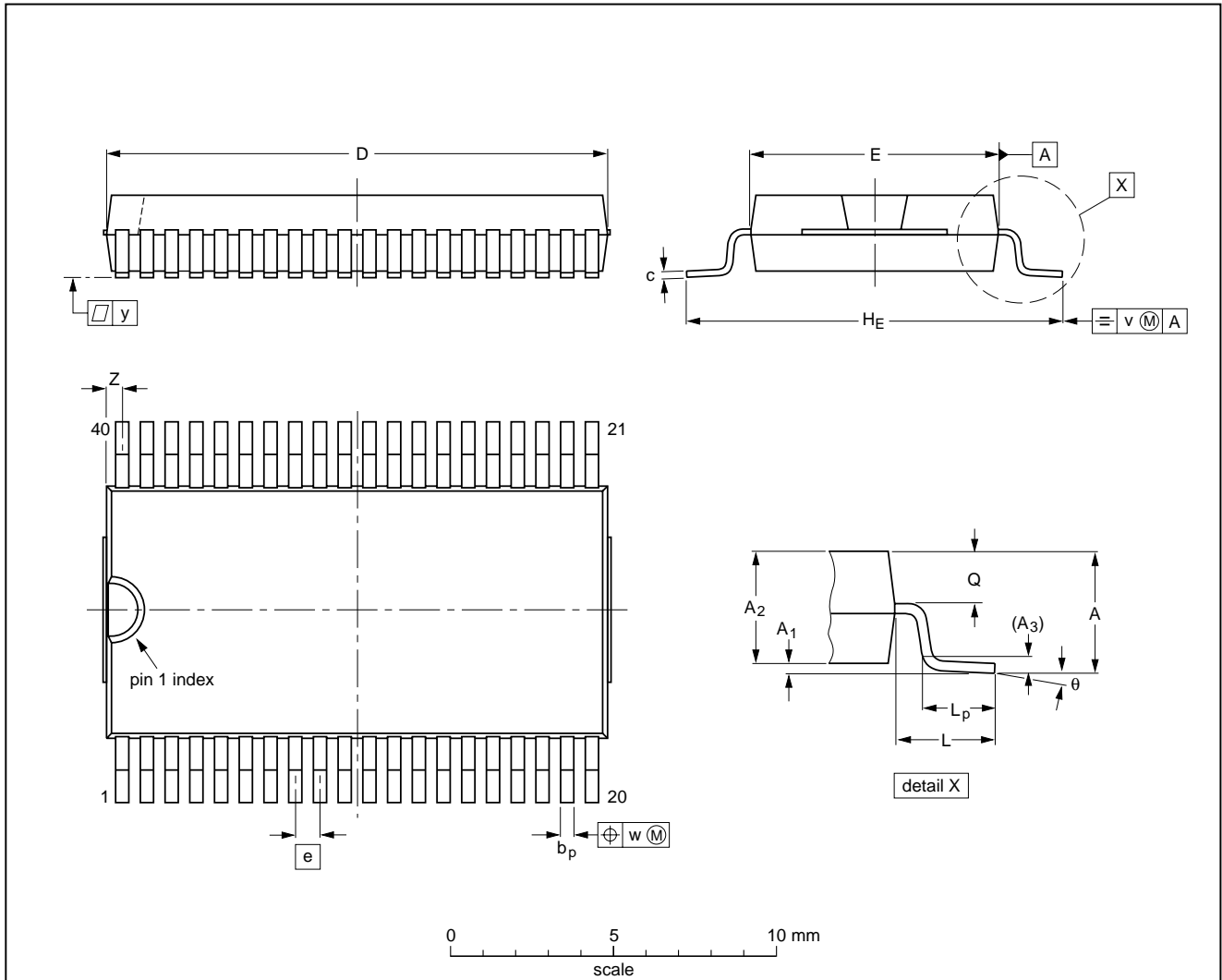

DIMENSIONS (inch dimensions are derived from the original mm dimensions)

UNIT	A max.	A ₁	A ₂	A ₃	b _p	c	D ⁽¹⁾	E ⁽²⁾	e	H _E	L	L _p	Q	v	w	y	z ⁽¹⁾	θ
mm	2.70	0.3 0.1	2.45 2.25	0.25	0.42 0.30	0.22 0.14	15.6 15.2	7.6 7.5	0.762	12.3 11.8	2.25	1.7 1.5	1.15 1.05	0.2	0.1	0.1	0.6 0.3	7° 0°
inches	0.11	0.012 0.004	0.096 0.089	0.010	0.017 0.012	0.0087 0.0055	0.61 0.60	0.30 0.29	0.03	0.48 0.46	0.089	0.067 0.059	0.045 0.041	0.008	0.004	0.004	0.024 0.012	

Notes

1. Plastic or metal protrusions of 0.4 mm maximum per side are not included.
2. Plastic interlead protrusions of 0.25 mm maximum per side are not included.

OUTLINE VERSION	REFERENCES				EUROPEAN PROJECTION	ISSUE DATE
	IEC	JEDEC	EIAJ			
SOT158-1						92-11-17 95-01-24

Speech and handsfree IC

TEA1098

SOLDERING

Introduction to soldering surface mount packages

This text gives a very brief insight to a complex technology. A more in-depth account of soldering ICs can be found in our *"Data Handbook IC26; Integrated Circuit Packages"* (document order number 9398 652 90011).

There is no soldering method that is ideal for all surface mount IC packages. Wave soldering can still be used for certain surface mount ICs, but it is not suitable for fine pitch SMDs. In these situations reflow soldering is recommended.

Reflow soldering

Reflow soldering requires solder paste (a suspension of fine solder particles, flux and binding agent) to be applied to the printed-circuit board by screen printing, stencilling or pressure-syringe dispensing before package placement.

Several methods exist for reflowing; for example, convection or convection/infrared heating in a conveyor type oven. Throughput times (preheating, soldering and cooling) vary between 100 and 200 seconds depending on heating method.

Typical reflow peak temperatures range from 215 to 250 °C. The top-surface temperature of the packages should preferably be kept below 220 °C for thick/large packages, and below 235 °C for small/thin packages.

Wave soldering

Conventional single wave soldering is not recommended for surface mount devices (SMDs) or printed-circuit boards with a high component density, as solder bridging and non-wetting can present major problems.

To overcome these problems the double-wave soldering method was specifically developed.

If wave soldering is used the following conditions must be observed for optimal results:

- Use a double-wave soldering method comprising a turbulent wave with high upward pressure followed by a smooth laminar wave.
- For packages with leads on two sides and a pitch (e):
 - larger than or equal to 1.27 mm, the footprint longitudinal axis is **preferred** to be parallel to the transport direction of the printed-circuit board;
 - smaller than 1.27 mm, the footprint longitudinal axis **must** be parallel to the transport direction of the printed-circuit board.

The footprint must incorporate solder thieves at the downstream end.

- For packages with leads on four sides, the footprint must be placed at a 45° angle to the transport direction of the printed-circuit board. The footprint must incorporate solder thieves downstream and at the side corners.

During placement and before soldering, the package must be fixed with a droplet of adhesive. The adhesive can be applied by screen printing, pin transfer or syringe dispensing. The package can be soldered after the adhesive is cured.

Typical dwell time is 4 seconds at 250 °C.

A mildly-activated flux will eliminate the need for removal of corrosive residues in most applications.

Manual soldering

Fix the component by first soldering two diagonally-opposite end leads. Use a low voltage (24 V or less) soldering iron applied to the flat part of the lead. Contact time must be limited to 10 seconds at up to 300 °C.

When using a dedicated tool, all other leads can be soldered in one operation within 2 to 5 seconds between 270 and 320 °C.

Speech and handsfree IC

TEA1098

Suitability of surface mount IC packages for wave and reflow soldering methods

PACKAGE	SOLDERING METHOD	
	WAVE	REFLOW ⁽¹⁾
BGA, LFBGA, SQFP, TFBGA	not suitable	suitable
HBCC, HLQFP, HSQFP, HSOP, HTQFP, HTSSOP, SMS	not suitable ⁽²⁾	suitable
PLCC ⁽³⁾ , SO, SOJ	suitable	suitable
LQFP, QFP, TQFP	not recommended ⁽³⁾⁽⁴⁾	suitable
SSOP, TSSOP, VSO	not recommended ⁽⁵⁾	suitable

Notes

- All surface mount (SMD) packages are moisture sensitive. Depending upon the moisture content, the maximum temperature (with respect to time) and body size of the package, there is a risk that internal or external package cracks may occur due to vaporization of the moisture in them (the so called popcorn effect). For details, refer to the Drypack information in the "Data Handbook IC26; Integrated Circuit Packages; Section: Packing Methods".
- These packages are not suitable for wave soldering as a solder joint between the printed-circuit board and heatsink (at bottom version) can not be achieved, and as solder may stick to the heatsink (on top version).
- If wave soldering is considered, then the package must be placed at a 45° angle to the solder wave direction. The package footprint must incorporate solder thieves downstream and at the side corners.
- Wave soldering is only suitable for LQFP, TQFP and QFP packages with a pitch (e) equal to or larger than 0.8 mm; it is definitely not suitable for packages with a pitch (e) equal to or smaller than 0.65 mm.
- Wave soldering is only suitable for SSOP and TSSOP packages with a pitch (e) equal to or larger than 0.65 mm; it is definitely not suitable for packages with a pitch (e) equal to or smaller than 0.5 mm.

DATA SHEET STATUS

DATA SHEET STATUS ⁽¹⁾	PRODUCT STATUS ⁽²⁾	DEFINITIONS
Objective data	Development	This data sheet contains data from the objective specification for product development. Philips Semiconductors reserves the right to change the specification in any manner without notice.
Preliminary data	Qualification	This data sheet contains data from the preliminary specification. Supplementary data will be published at a later date. Philips Semiconductors reserves the right to change the specification without notice, in order to improve the design and supply the best possible product.
Product data	Production	This data sheet contains data from the product specification. Philips Semiconductors reserves the right to make changes at any time in order to improve the design, manufacturing and supply. Changes will be communicated according to the Customer Product/Process Change Notification (CPCN) procedure SNW-SQ-650A.

Notes

- Please consult the most recently issued data sheet before initiating or completing a design.
- The product status of the device(s) described in this data sheet may have changed since this data sheet was published. The latest information is available on the Internet at URL <http://www.semiconductors.philips.com>.

Speech and handsfree IC

TEA1098

DEFINITIONS

Short-form specification — The data in a short-form specification is extracted from a full data sheet with the same type number and title. For detailed information see the relevant data sheet or data handbook.

Limiting values definition — Limiting values given are in accordance with the Absolute Maximum Rating System (IEC 60134). Stress above one or more of the limiting values may cause permanent damage to the device. These are stress ratings only and operation of the device at these or at any other conditions above those given in the Characteristics sections of the specification is not implied. Exposure to limiting values for extended periods may affect device reliability.

Application information — Applications that are described herein for any of these products are for illustrative purposes only. Philips Semiconductors make no representation or warranty that such applications will be suitable for the specified use without further testing or modification.

DISCLAIMERS

Life support applications — These products are not designed for use in life support appliances, devices, or systems where malfunction of these products can reasonably be expected to result in personal injury. Philips Semiconductors customers using or selling these products for use in such applications do so at their own risk and agree to fully indemnify Philips Semiconductors for any damages resulting from such application.

Right to make changes — Philips Semiconductors reserves the right to make changes, without notice, in the products, including circuits, standard cells, and/or software, described or contained herein in order to improve design and/or performance. Philips Semiconductors assumes no responsibility or liability for the use of any of these products, conveys no licence or title under any patent, copyright, or mask work right to these products, and makes no representations or warranties that these products are free from patent, copyright, or mask work right infringement, unless otherwise specified.

BARE DIE DISCLAIMER

All die are tested and are guaranteed to comply with all data sheet limits up to the point of wafer sawing for a period of ninety (90) days from the date of Philips' delivery. If there are data sheet limits not guaranteed, these will be separately indicated in the data sheet. There are no post packing tests performed on individual die or wafer. Philips Semiconductors has no control of third party procedures in the sawing, handling, packing or assembly of the die. Accordingly, Philips Semiconductors assumes no liability for device functionality or performance of the die or systems after third party sawing, handling, packing or assembly of the die. It is the responsibility of the customer to test and qualify their application in which the die is used.

Philips Semiconductors – a worldwide company

Contact information

For additional information please visit <http://www.semiconductors.philips.com>. Fax: **+31 40 27 24825**

For sales offices addresses send e-mail to: sales.addresses@www.semiconductors.philips.com.

© Koninklijke Philips Electronics N.V. 2001

SCA73

All rights are reserved. Reproduction in whole or in part is prohibited without the prior written consent of the copyright owner.

The information presented in this document does not form part of any quotation or contract, is believed to be accurate and reliable and may be changed without notice. No liability will be accepted by the publisher for any consequence of its use. Publication thereof does not convey nor imply any license under patent- or other industrial or intellectual property rights.

Printed in The Netherlands

403502/06/pp36

Date of release: 2001 Aug 24

Document order number: 9397 750 08576

Let's make things better.

**Philips
Semiconductors**



PHILIPS