

Micropower Regulator with Comparator and Shutdown

FEATURES

- 8-Lead MiniDIP
- 40 μ A Supply Current
- 125mA Output Current
- 2.5V Reference Voltage
- Reference Output Sources 2mA and Sinks 2mA
- Open Collector Comparator Sinks 10mA
- Logic Shutdown
- 0.2V Dropout Voltage
- Thermal Limiting

APPLICATIONS

- Battery Systems
- Battery Backup System
- Portable Terminals
- Portable Instruments
- Memory Keep Alive

DESCRIPTION

The LT1120 is a combination micropower positive regulator and free collector comparator on a single monolithic chip. With only 40 μ A supply current, the LT1120 can supply over 125mA of output current. Input voltage range is from 4.5V to 36V and dropout voltage is 0.6V at 125mA. Dropout voltage decreases with lower load currents. Also included on the chip is a class B output 2.5V reference that can either source or sink current. A shutdown pin allows logic shutdown of the output.

The comparator can be used for system or battery monitoring. For example, the comparator can be used to warn of low system voltage. Frequency compensation of the comparator for amplifier applications can be obtained by adding external output capacitance.

The 2.5V reference will source or sink current. This allows it to be used as a supply splitter or auxiliary output.

5V Regulator

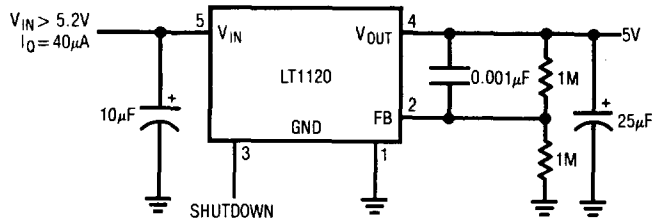

Dropout Voltage and Supply Current

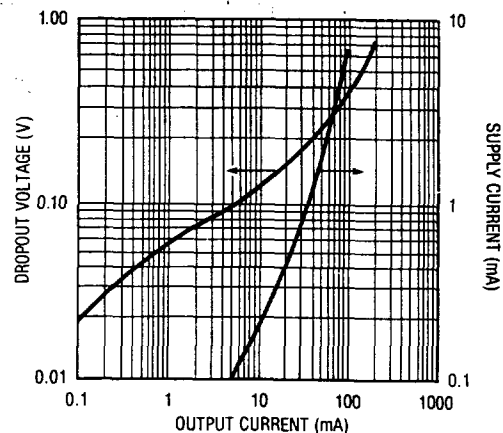

ABSOLUTE MAXIMUM RATINGS

Input Voltage 36V
 NPN Collector Voltage 36V
 Output Short Circuit Duration Indefinite
 Power Dissipation Internally Limited

Operating Temperature Range
 LT1120C 0°C to 100°C
 Storage Temperature Range
 LT1120C -65°C to 150°C

PACKAGE/ORDER INFORMATION

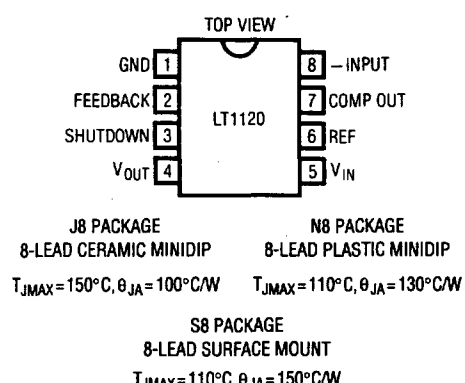
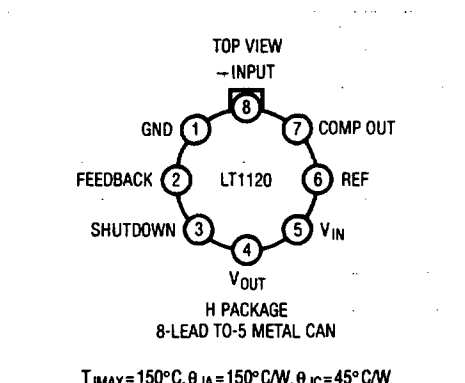
 <p>J8 PACKAGE 8-LEAD CERAMIC MINIDIP T_{JMAX} = 150°C, θ_{JA} = 100°C/W</p> <p>N8 PACKAGE 8-LEAD PLASTIC MINIDIP T_{JMAX} = 110°C, θ_{JA} = 130°C/W</p> <p>S8 PACKAGE 8-LEAD SURFACE MOUNT T_{JMAX} = 110°C, θ_{JA} = 150°C/W</p>	ORDER PART NUMBER	 <p>H PACKAGE 8-LEAD TO-5 METAL CAN T_{JMAX} = 150°C, θ_{JA} = 150°C/W, θ_{JC} = 45°C/W</p>	ORDER PART NUMBER
	LT1120CJ8 LT1120CN8 LT1120CS8		LT1120CH
	S8 PART MARKING		
	1120		

Consult factory for Industrial and Military grade parts.

ELECTRICAL CHARACTERISTICS T_J = 25°C

PARAMETER	CONDITIONS	MIN	TYP	MAX	UNITS
Reference					
Reference Voltage	4.5V ≤ V _{IN} ≤ 36V	2.46	2.50	2.54	V
Line Regulation	4.5V ≤ V _{IN} ≤ 36V		0.01	0.015	%/V
Load Regulation	-2.0mA ≤ I _{REF} ≤ 2mA, V _{IN} = 12V		0.3	0.6	%
Output Source Current	V _{IN} = 5V	2	4		mA
Output Sink Current	V _{IN} = 5V	2	4		mA
Temperature Stability			1		%
Regulator					
Supply Current	V _{IN} = 6V, I _{OUT} ≤ 100μA V _{IN} = 36V, I _{OUT} ≤ 100μA V _{IN} = 12V, I _{OUT} = 125mA		45 75 11	80 100 20	μA μA mA
Output Current	(V _{IN} - V _{OUT}) ≥ 1V, V _{IN} ≥ 6V	125			mA
Load Regulation	(V _{IN} - V _{OUT}) ≥ 1V, V _{IN} ≥ 6V		0.2	0.5	%
Line Regulation	6V ≤ V _{IN} ≤ 36V		0.01	0.015	%/V
Dropout Voltage	I _{OUT} = 100μA I _{OUT} = 125mA		0.02	0.05	V
			0.4	0.65	V
Feedback Sense Voltage	V _{IN} = 12V	2.44	2.5	2.56	V
Shutdown Pin Voltage	V _{OUT} ≤ 0.5V	Normal		0.4	V
		Shutdown	2.2	1.4	V
Shutdown Pin Current	V _{IN} = 1.4V		25		μA

ELECTRICAL CHARACTERISTICS $T_J = 25^\circ\text{C}$

PARAMETER	CONDITIONS	MIN	TYP	MAX	UNITS
Regulator					
Feedback Bias Current			15	40	nA
Minimum Load Current	$V_{IN} = 36\text{V}$		1	5	μA
Short Circuit Current	$V_{IN} = 36\text{V}$		300	400	mA
Comparator					
Offset Voltage	$0\text{V} \leq V_{CM} \leq 35\text{V}, V_{IN} = 36\text{V}$		3	7	mV
Bias Current	$0\text{V} \leq V_{CM} \leq 35\text{V}, V_{IN} = 36\text{V}$ (Note 1)		15	40	nA
Offset Current	$0\text{V} \leq V_{CM} \leq 35\text{V}, V_{IN} = 36\text{V}$		4	15	nA
Gain	$\Delta V_{OUT} = 29\text{V}, R_L = 20\text{k}$	2000	10000		V/V
Common Mode Rejection	$0\text{V} \leq V_{CM} \leq 35\text{V}, V_{IN} = 36\text{V}$	80	94		dB
Power Supply Rejection	$4.5\text{V} \leq V_S \leq 36\text{V}$	80	96		dB
Output Sink Current	$V_{IN} = 4.5\text{V}$	10	18		mA
Saturation Voltage	$I_{OUT} = 1\text{mA}$		0.4	0.6	V
Input Voltage Range		0		$V_{IN} - 1$	V
Response Time			5		μs
Leakage Current				2	μA

ELECTRICAL CHARACTERISTICS

PARAMETER	CONDITIONS	MIN	TYP	MAX	UNITS	
Reference						
Reference Voltage	$4.5\text{V} \leq V_{IN} \leq 36\text{V}$	● 2.40	2.50	2.55	V	
Line Regulation	$4.5\text{V} \leq V_{IN} \leq 36\text{V}$	●	0.01	0.02	%/V	
Load Regulation	$-2.0\text{mA} \leq I_{REF} \leq 2\text{mA}, V_{IN} = 12\text{V}$	●	0.4	0.8	%	
Output Source Current	$V_{IN} = 5\text{V}$	● 2			mA	
Output Sink Current	$V_{IN} = 5\text{V}$	● 2			mA	
Regulator						
Supply Current	$V_{IN} = 6\text{V}, I_{OUT} \leq 100\mu\text{A}$ $V_{IN} = 36\text{V}, I_{OUT} \leq 100\mu\text{A}$ $V_{IN} = 12\text{V}, I_{OUT} = 125\text{mA}$	●	65 85 11	95 100 20	μA μA mA	
Output Current	$(V_{IN} - V_{OUT}) \geq 1\text{V}, V_{IN} \geq 6\text{V}$	●	125		mA	
Load Regulation	$(V_{IN} - V_{OUT}) \geq 1\text{V}, V_{IN} \geq 6\text{V}$	●		1	%	
Line Regulation	$6\text{V} \leq V_{IN} \leq 36\text{V}$	●		0.02	%/V	
Dropout Voltage	$I_{OUT} = 100\mu\text{A}$ $I_{OUT} = 125\text{mA}$	●		0.06 0.85	V V	
Feedback Sense Voltage	$V_{IN} = 12\text{V}$	●	2.38	2.5	2.57	V
Feedback Bias Current		●		50	nA	
Minimum Load Current	$V_{IN} = 36\text{V}$	●		50	μA	
Short Circuit Current	$V_{IN} = 36\text{V}$	●	300	400	mA	

ELECTRICAL CHARACTERISTICS

PARAMETER	CONDITIONS		MIN	TYP	MAX	UNITS
Comparator						
Offset Voltage		●			10	mV
Bias Current	$V_{IN} = 36V$ (Note 1)	●		15	60	nA
Gain	$\Delta V_{OUT} = 29V, R_L = 20k$	●	1000			V/V
Output Sink Current	$V_{IN} = 4.5V$ (Note 2)	●	5	10		mA
Leakage Current	$V_{IN} = 36V$	●			8	μA

The ● denotes specifications which apply over full operating temperature range.

Note 1: For $0V \leq V_{CM} \leq 0.1V$ and $T_A > 85^\circ C$ I bias max is 100nA.

Note 2: For $T_A \leq -40^\circ C$ output $I_{SINK (MIN)}$ to 2.5mA.

PIN FUNCTIONS

Pin 1—Ground.

Pin 2—Feedback. This is the feedback point of the regulator. When operating, it is nominally at 2.5V. Optimum source resistance is 200k to 500k. The feedback pin should not be driven below ground or more positive than 5V.

Pin 3—Shutdown. A logic 1 shuts off main regulator. Caution: noise or leakage into the shutdown pin can affect output voltage.

Pin 4—Regulator Output. Main output, requires $10\mu F$ output capacitor. Can be shorted to V_{IN} or ground without damaging device.

Pin 5—Input Supply. Bypass with $10\mu F$ cap. Must always be more positive than ground.

Pin 6—Reference. 2.5V can source or sink current. May be shorted to ground or up to 5V. Voltages in excess of 5V can damage the device.

Pin 7—Comparator Output. May be connected to any voltage from ground to 36V more positive than ground (operates above V_{IN}). Short circuit protected.

Pin 8—Comparator Input. Inverting comparator input.

TYPICAL PERFORMANCE CHARACTERISTICS

Regulator Load Regulation

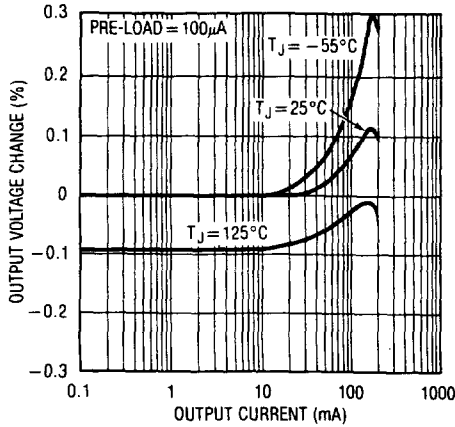

Supply Current

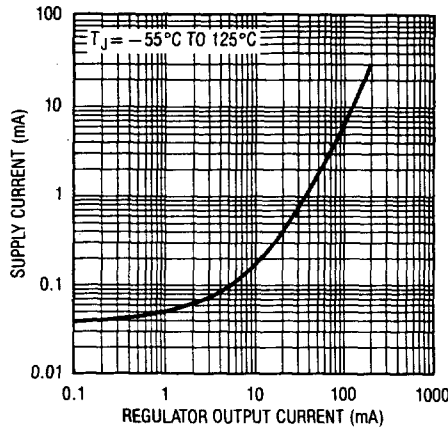

Regulator Short Circuit Current

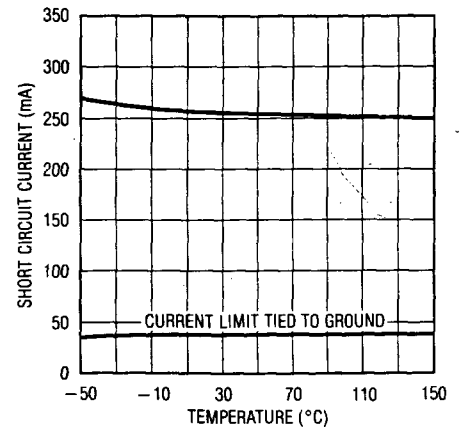

Dropout Voltage

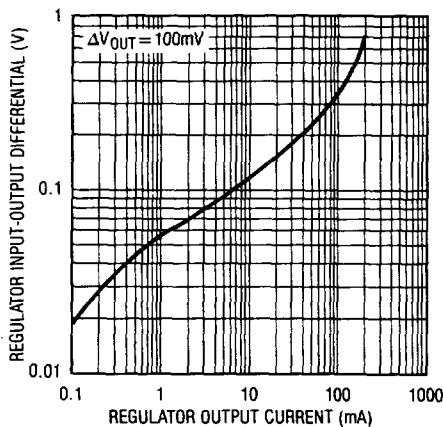

Regulator Minimum Load Current

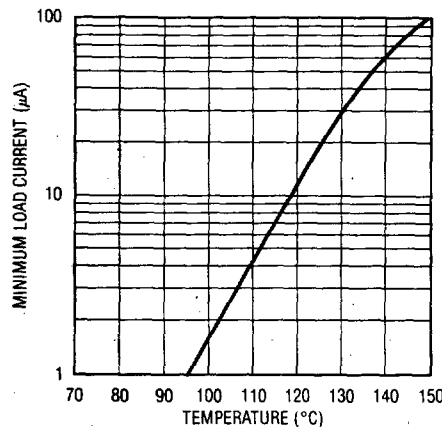

Regulator Ripple Rejection

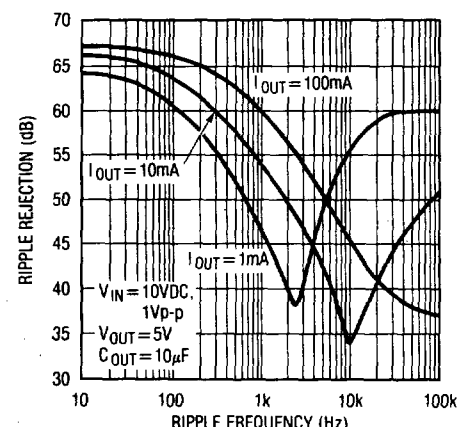

Supply Current

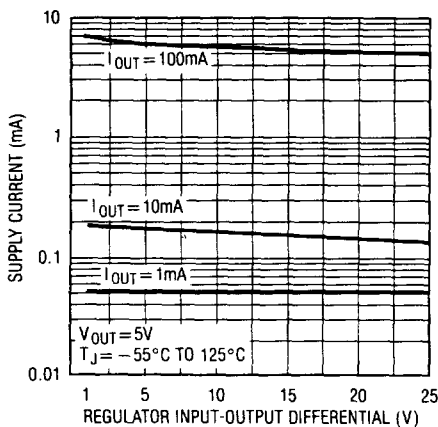

Supply Current at Dropout

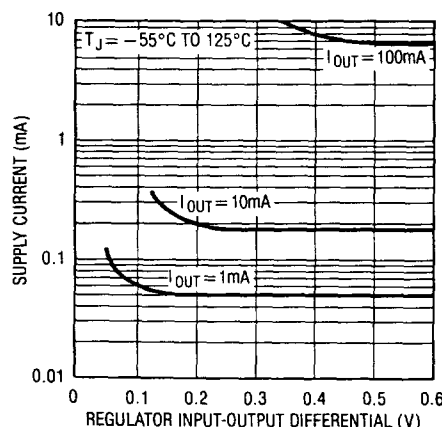

Reference Regulation

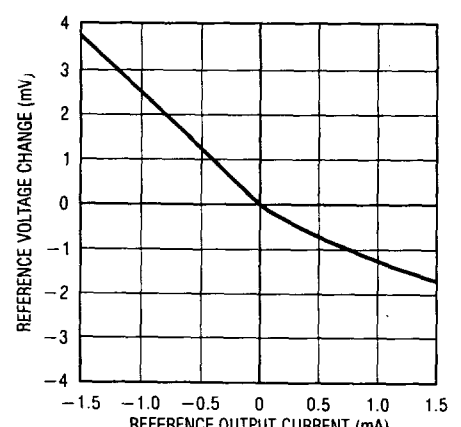

TYPICAL PERFORMANCE CHARACTERISTICS

Comparator Input Bias Current

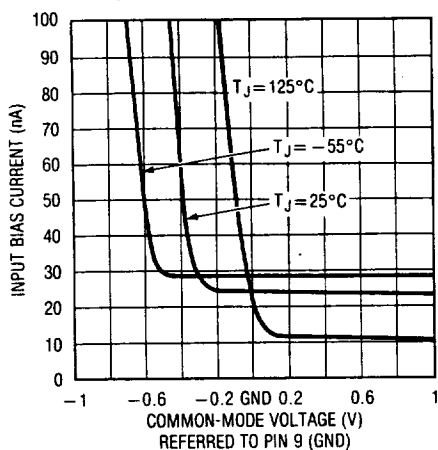

Feedback Pin Current

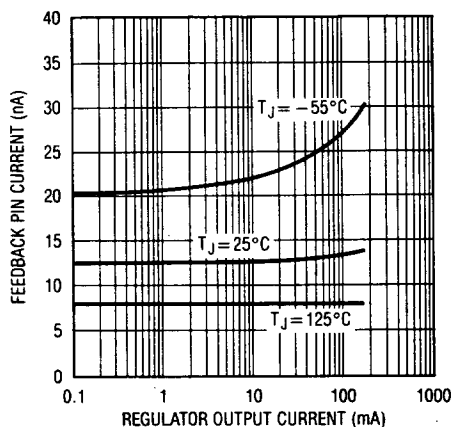

Regulator Thermal Regulation

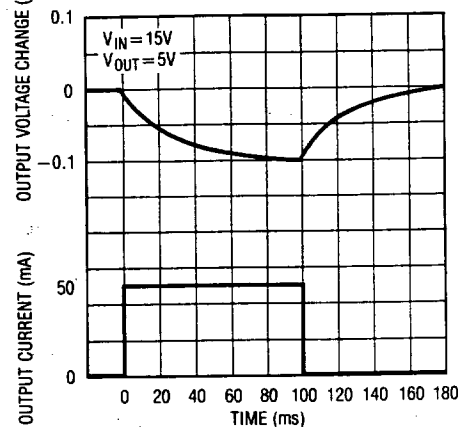

LT1120 Turn-On Characteristic

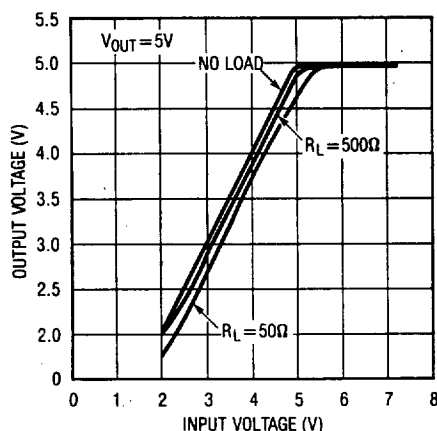

4

APPLICATION HINTS

The LT1120 is especially suited for micropower system applications. For example, the comparator section of the LT1020 may be used as a battery checker to provide an indication of low battery. Another type of system application for the LT1120 would be to generate the equivalent of split supplies off of a single power input. The regulator section provides regulated output voltage and the reference, which can both source and sink current is then an artificial system ground providing a split supply for the system.

For many applications the comparator can be frequency compensated to operate as an amplifier. Compensation values for various gains are given in the datasheet. The comparator gain is purposely low to make it easier to frequency compensate as an amplifier. The NPN output is capable of sinking 10mA and can drive loads connected to voltages in excess of the positive power supply. This is useful for driving switches or linear regulators off of a higher input voltage.

APPLICATION HINTS

Reference

Internal to the LT1120 is a 2.5V trimmed class B output reference. The reference was designed to be able to source or sink current so it could be used in supply splitting applications as well as a general purpose reference for external circuitry. The design of the reference allows it to source typically 4 or 5mA and sink 2mA. The available source and sink current decreases as temperature increases. It is sometimes desirable to decrease the AC output impedance by placing an output capacitor on them. The reference in the LT1020 becomes unstable with large capacitive loads placed directly on it. When using an output capacitor, about 20Ω should be used to isolate the capacitor from the reference pin. This 20Ω resistor can be placed directly in series with the capacitor or alternatively the reference line can have 20Ω placed in series with it and then a capacitor to ground. This is shown in Figure 1. Other than placing large capacitive loads on the reference, no other precautions are necessary and the reference is stable with nominal stray capacitances.

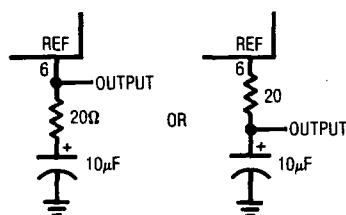

Figure 1. Bypassing Reference

Overload Protection

The main regulator in the LT1120 is current limited at approximately 250mA. The current limit is stable with both input voltage and temperature.

Like most other IC regulators, a minimum load is required on the output of the LT1120 to maintain regulation. For most standard regulators this is normally specified at 5mA. Of course, for a micropower regulator this would be a tremendously large current. The output current must be large enough to absorb all the leakage current of the pass transistor at the maximum operating temperature. It also affects the transient response; low output currents have long recovery times from load transients. At high operating temperatures the minimum load current increases and having too low of a load current may cause the output to go unregulated. Devices are tested for minimum load current at high temperature. The output voltage setting resistors to the feedback terminal can usually be used to provide the minimum load current.

Frequency Compensation

The LT1120 is frequency compensated by a dominant pole on the output. An output capacitor of $10\mu\text{F}$ is usually large enough to provide good stability. **Increasing the output capacitor above $10\mu\text{F}$ further improves stability.** In order to ensure stability, a feedback capacitor is needed between the output pin and the feedback pin. This is because stray capacitance can form another pole with the large value of feedback resistors used with the LT1120. Also, a feedback capacitor minimizes noise pickup and improves ripple rejection.

With the large dynamic operating range of the output current, 10000:1, frequency response changes widely. Low AC impedance capacitors are needed to insure stability. While solid tantalum are best, aluminum electrolytics can be used but larger capacitor values may be needed.

TYPICAL APPLICATIONS

Regulator with Output Voltage Monitor

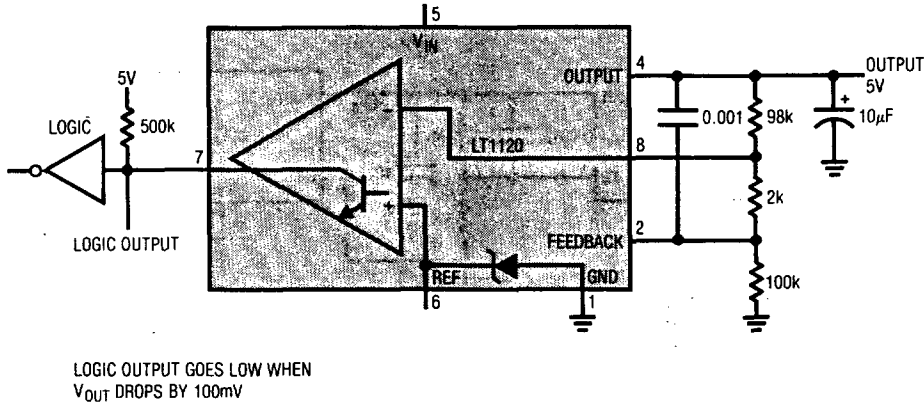

Compensating the Comparator as an Op Amp

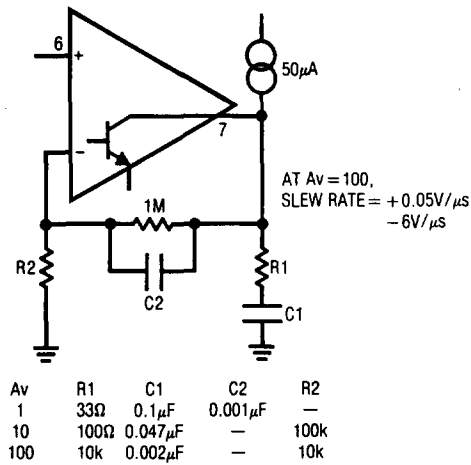

1 Amp Low Dropout Regulator

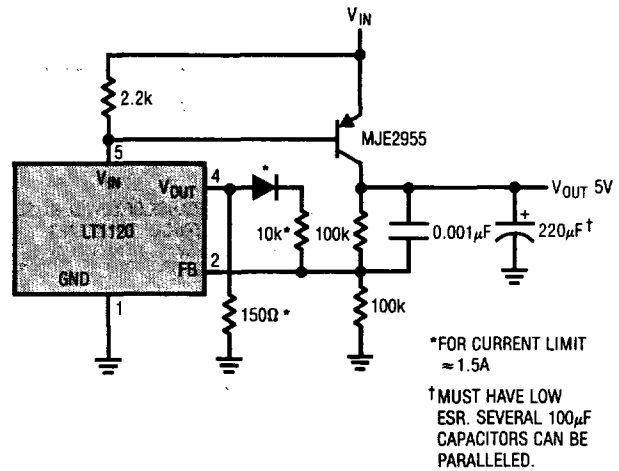

5V Regulator

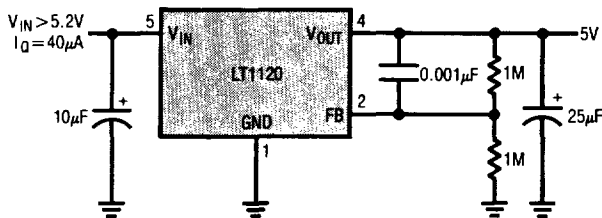

Regulator with Improved Transient Response

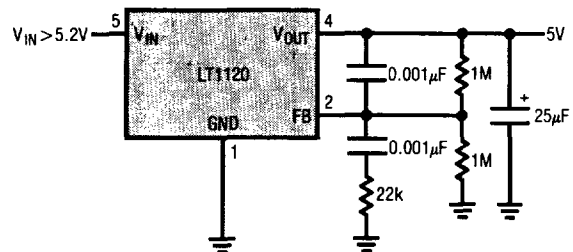

TYPICAL APPLICATIONS

Battery Backup Regulator

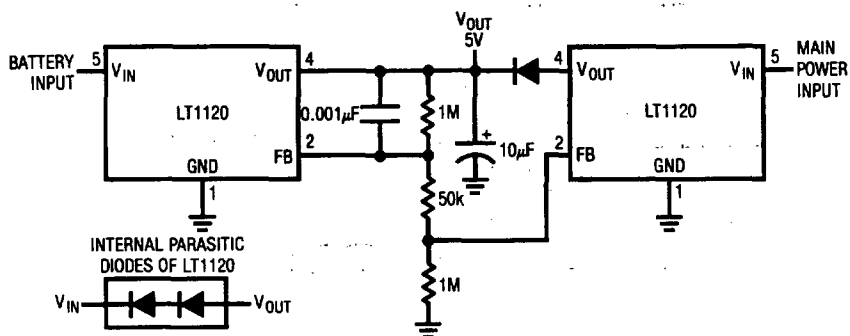

5V Regulator with Feedback Shutdown

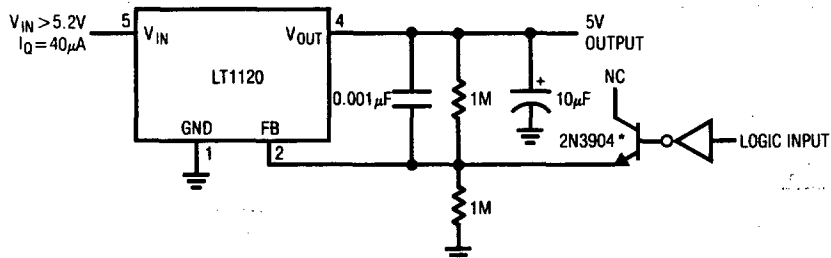

*TRANSISTOR USED BECAUSE OF LOW LEAKAGE CHARACTERISTICS.
TO TURN OFF THE OUTPUT OF THE LT1120
FORCE FB (PIN 2) > 2.5V.

Current Limited 1 Amp Regulator

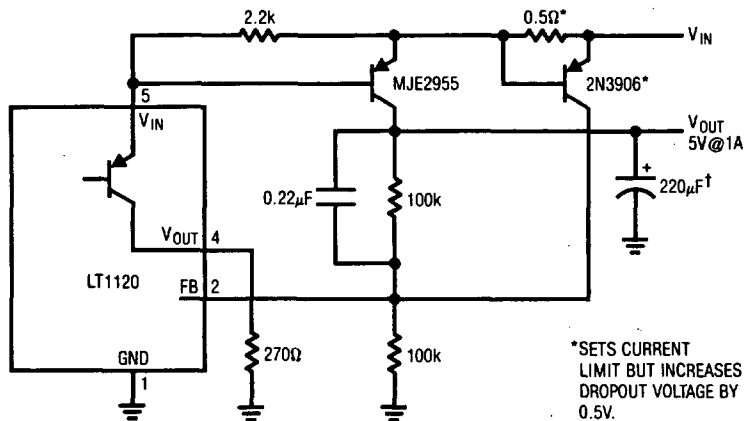

*SETS CURRENT
LIMIT BUT INCREASES
DROPOUT VOLTAGE BY
0.5V.

† MUST HAVE LOW
ESR. SEVERAL 100µF
CAPACITORS CAN BE
PARALLELED.

SCHEMATIC DIAGRAM

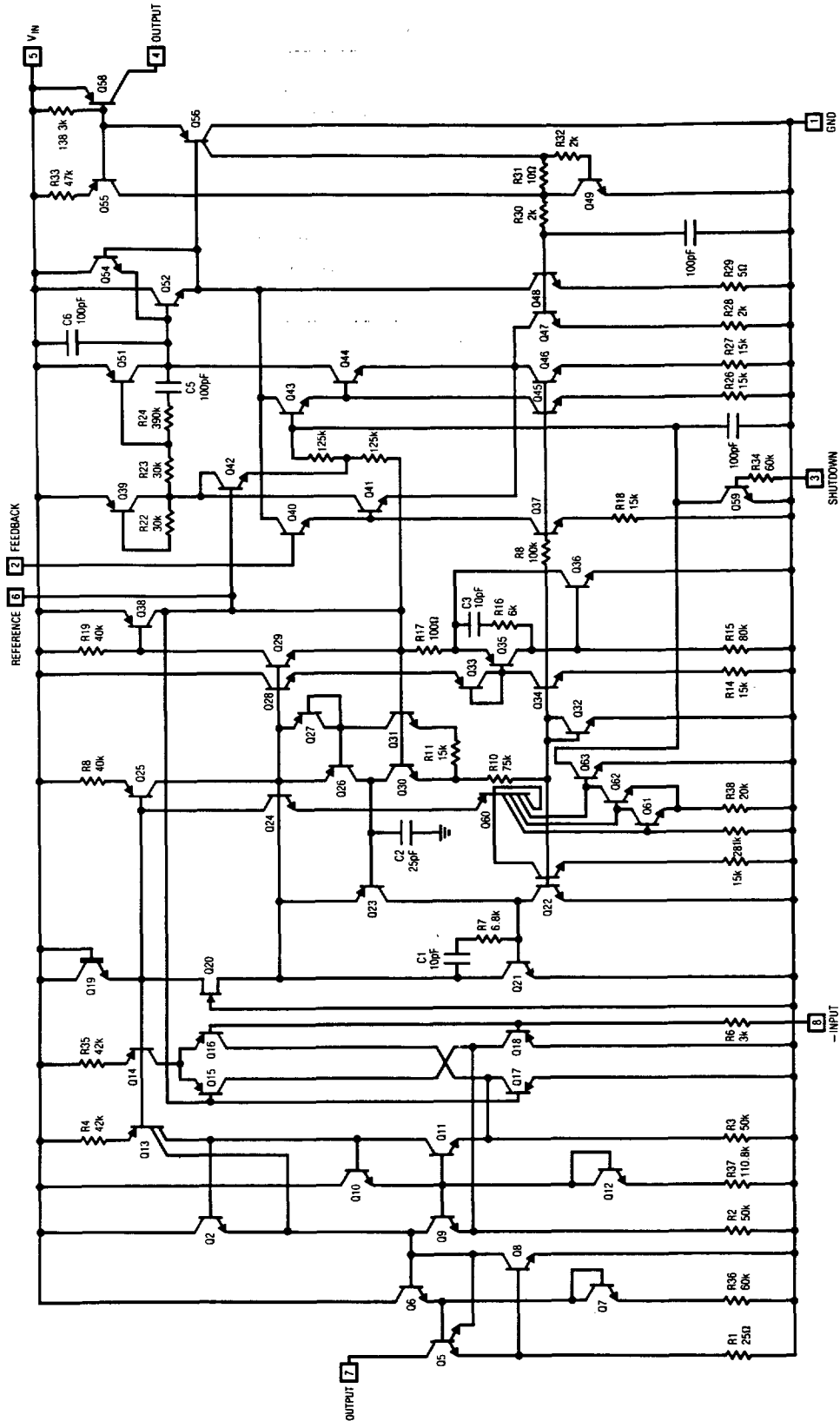

BLOCK DIAGRAM

