

# MITSUBISHI MICROCOMPUTERS

## 38B4 Group

SINGLE-CHIP 8-BIT CMOS MICROCOMPUTER

### DESCRIPTION

The 38B4 group is the 8-bit microcomputer based on the 740 family core technology.

The 38B4 group has six 8-bit timers, a 16-bit timer, a fluorescent display automatic display circuit, 12-channel 10-bit A-D converter, a serial I/O with automatic transfer function, which are available for controlling musical instruments and household appliances.

### FEATURES

- Basic machine-language instructions ..... 71
- Minimum instruction execution time ..... 0.48  $\mu$ s (at 4.2 MHz oscillation frequency)
- Memory size
  - ROM ..... 48K to 60K bytes
  - RAM ..... 1024 to 2048 bytes
- Programmable input/output ports ..... 51
- High-breakdown-voltage output ports ..... 36
- Software pull-up resistors (Ports P5, P6<sub>1</sub> to P6<sub>5</sub>, P7, P8<sub>4</sub> to P8<sub>7</sub>, P9)
- Interrupts ..... 21 sources, 16 vectors
- Timers ..... 8-bit X 6, 16-bit X 1
- Serial I/O1 (Clock-synchronized) ..... 8-bit X 1 (max. 256-byte automatic transfer function)
- Serial I/O2 (UART or Clock-synchronized) ..... 8-bit X 1
- PWM ..... 14-bit X 1 8-bit X 1 (also functions as timer 6)
- A-D converter ..... 10-bit X 12 channels
- Fluorescent display function ..... Total 40 control pins
- Interrupt interval determination function ..... 1
- Watchdog timer ..... 20-bit X 1

- Buzzer output ..... 1
- Clock generating circuit ..... Built-in 2 circuits (connect to external ceramic resonator or quartz-crystal oscillator)
- Power source voltage
  - In high-speed mode ..... 4.0 to 5.5 V (at 4.2 MHz oscillation frequency) 2.7 to 5.5 V (at 2.0 MHz oscillation frequency)
  - In middle-speed mode ..... 2.7 to 5.5 V (at 4.2 MHz oscillation frequency)
  - In low-speed mode ..... 2.7 to 5.5 V (at 32 kHz oscillation frequency)
- Power dissipation
  - In high-speed mode ..... 35 mW (at 4.2 MHz oscillation frequency)
  - In low-speed mode ..... 60  $\mu$ W (at 32 kHz oscillation frequency, at 3 V power source voltage)
  - In stop mode ..... 1  $\mu$ A (at clock stop)
- Operating temperature range ..... -20 to 85 °C

### APPLICATION

Musical instruments, VCR, household appliances, etc.

### PIN CONFIGURATION (TOP VIEW)

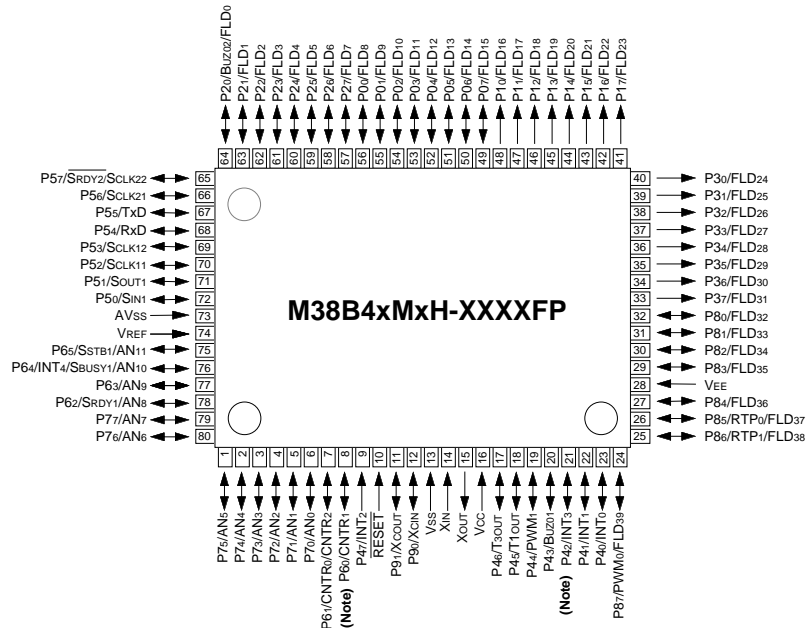

Note: In the mask option type P, INT<sub>3</sub> and CNTR<sub>1</sub> cannot be used.

Package type : 80P6N-A  
80-pin plastic-molded QFP

Fig. 1 Pin configuration of M38B4xMxH-XXXXFP

FUNCTIONAL BLOCK

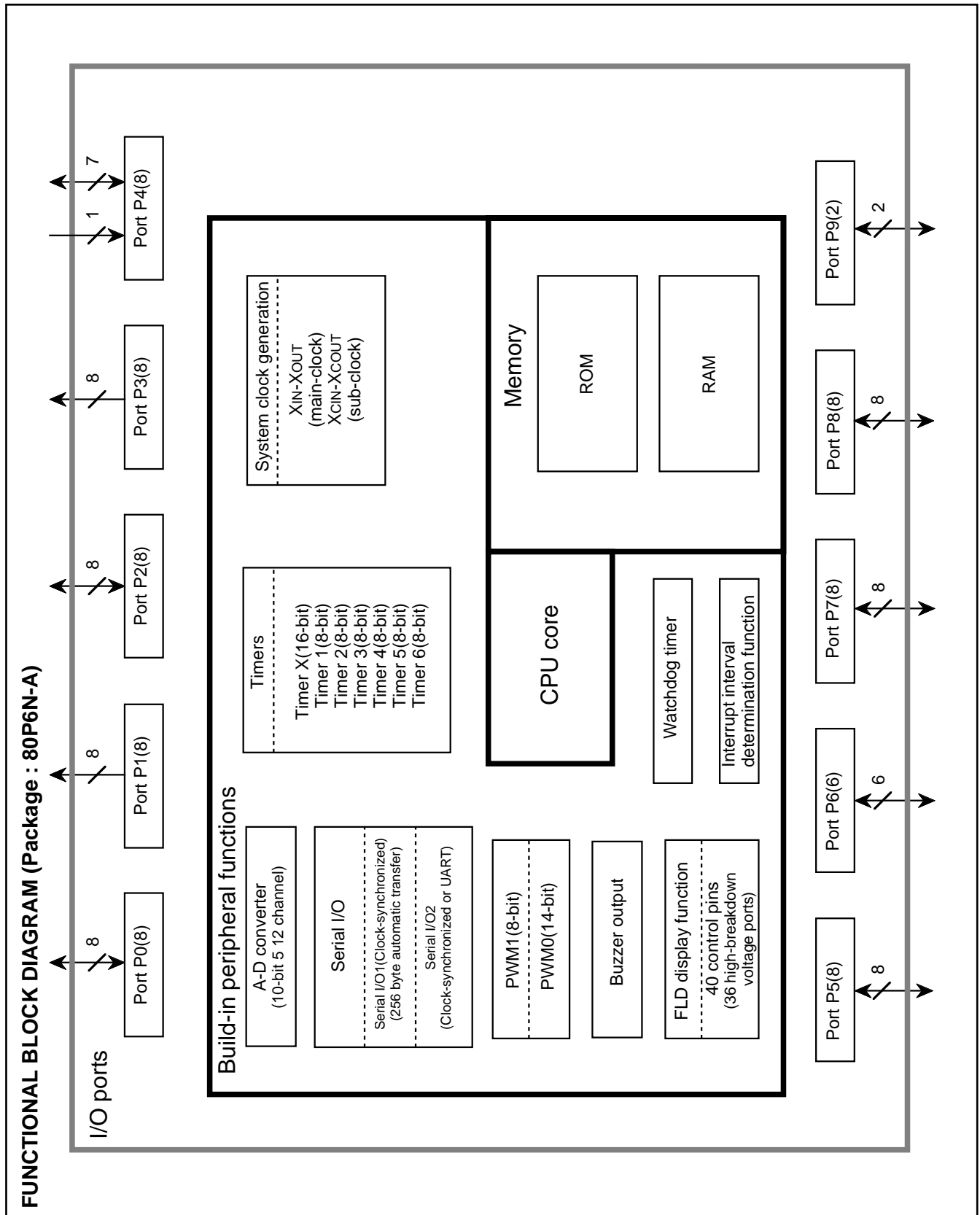

Fig. 2 Functional block diagram

**PIN DESCRIPTION**

**Table 1 Pin description (1)**

Pin	Name	Function	Function except a port function
VCC, VSS	Power source	<ul style="list-style-type: none"> <li>Apply voltage of 4.0–5.5 V to Vcc, and 0 V to Vss.</li> </ul>	
VEE	Pull-down power source	<ul style="list-style-type: none"> <li>Apply voltage supplied to pull-down resistors of ports P0, P1, and P3.</li> </ul>	
VREF	Reference voltage	<ul style="list-style-type: none"> <li>Reference voltage input pin for A-D converter.</li> </ul>	
AVSS	Analog power source	<ul style="list-style-type: none"> <li>Analog power source input pin for A-D converter.</li> <li>Connect to Vss.</li> </ul>	
RESET	Reset input	<ul style="list-style-type: none"> <li>Reset input pin for active "L".</li> </ul>	
XIN	Clock input	<ul style="list-style-type: none"> <li>Input and output pins for the main clock generating circuit.</li> <li>Feedback resistor is built in between XIN pin and XOUT pin.</li> </ul>	
XOUT	Clock output	<ul style="list-style-type: none"> <li>Connect a ceramic resonator or quartz-crystal oscillator between the XIN and XOUT pins to set the oscillation frequency.</li> <li>When an external clock is used, connect the clock source to the XIN pin and leave the XOUT pin open.</li> <li>The clock is used as the oscillating source of system clock.</li> </ul>	
P00/FLD8– P07/FLD15	I/O port P0	<ul style="list-style-type: none"> <li>8-bit I/O port.</li> <li>I/O direction register allows each pin to be individually programmed as either input or output.</li> <li>At reset, this port is set to input mode.</li> <li>A pull-down resistor is built in between port P0 and the VEE pin.</li> <li>CMOS compatible input level.</li> <li>High-breakdown-voltage P-channel open-drain output structure.</li> <li>At reset, this port is set to VEE level.</li> </ul>	<ul style="list-style-type: none"> <li>FLD automatic display pins</li> </ul>
P10/FLD16– P17/FLD23	Output port P1	<ul style="list-style-type: none"> <li>8-bit output port.</li> <li>A pull-down resistor is built in between port P1 and the VEE pin.</li> <li>High-breakdown-voltage P-channel open-drain output structure.</li> <li>At reset, this port is set to VEE level.</li> </ul>	<ul style="list-style-type: none"> <li>FLD automatic display pins</li> </ul>
P20/BUZ02/ FLD0– P27/FLD7	I/O port P2	<ul style="list-style-type: none"> <li>8-bit I/O port with the same function as port P0.</li> <li>Low-voltage input level.</li> <li>High-breakdown-voltage P-channel open-drain output structure.</li> </ul>	<ul style="list-style-type: none"> <li>FLD automatic display pins</li> <li>Buzzer output pin (P20)</li> </ul>
P30/FLD24– P37/FLD31	Output port P3	<ul style="list-style-type: none"> <li>8-bit output port.</li> <li>A pull-down resistor is built in between port P3 and the VEE pin.</li> <li>High-breakdown-voltage P-channel open-drain output structure.</li> <li>At reset, this port is set to VEE level.</li> </ul>	<ul style="list-style-type: none"> <li>FLD automatic display pins</li> </ul>
P40/INT0, P41/INT1, P42/INT3	I/O port P4	<ul style="list-style-type: none"> <li>7-bit I/O port with the same function as port P0.</li> <li>CMOS compatible input level</li> <li>N-channel open-drain output structure.</li> </ul>	<ul style="list-style-type: none"> <li>Interrupt input pins In the mask option type P, INT3 cannot be used.</li> </ul>
P43/BUZ01			<ul style="list-style-type: none"> <li>Buzzer output pin</li> </ul>
P44/PWM1			<ul style="list-style-type: none"> <li>PWM output pin (Timer output pin)</li> </ul>
P45/T1OUT, P46/T3OUT			<ul style="list-style-type: none"> <li>Timer output pin</li> </ul>
P47/INT2	Input port P4	<ul style="list-style-type: none"> <li>1-bit input port.</li> <li>CMOS compatible input level.</li> </ul>	<ul style="list-style-type: none"> <li>Interrupt input pin</li> </ul>

Table 2 Pin description (2)

Pin	Name	Function	Function except a port function	
P50/SIN1, P51/SOUT1, P52/SCLK11, P53/SCLK12	I/O port P5	<ul style="list-style-type: none"> <li>• 8-bit CMOS I/O port with the same function as port P0.</li> <li>• CMOS compatible input level.</li> <li>• CMOS 3-state output structure.</li> </ul>	<ul style="list-style-type: none"> <li>• Serial I/O1 function pins</li> </ul>	
P54/RxD, P55/TxD, P56/SCLK21, P57/SRDY2/ SCLK22			<ul style="list-style-type: none"> <li>• Serial I/O2 function pins</li> </ul>	
P60/CNTR1	I/O port P6	<ul style="list-style-type: none"> <li>• 1-bit I/O port with the same function as port P0.</li> <li>• CMOS compatible input level.</li> <li>• N-channel open-drain output structure.</li> </ul>	<ul style="list-style-type: none"> <li>• Timer input pin</li> </ul> In the mask option type P, CNTR1 cannot be used.	
P61/CNTR0/ CNTR2			<ul style="list-style-type: none"> <li>• Timer I/O pin</li> </ul>	
P62/SRDY1/ AN8			<ul style="list-style-type: none"> <li>• Serial I/O1 function pin</li> <li>• A-D conversion input pin</li> </ul>	
P63/AN9			<ul style="list-style-type: none"> <li>• A-D conversion input pin</li> <li>• Dimmer signal output pin</li> </ul>	
P64/INT4/ SBUSY1/AN10, P65/SSTB1/ AN11			<ul style="list-style-type: none"> <li>• Serial I/O1 function pin</li> <li>• A-D conversion input pin</li> <li>• Interrupt input pin (P64)</li> </ul>	
P70/AN0– P77/AN7	I/O port P7	<ul style="list-style-type: none"> <li>• 8-bit CMOS I/O port with the same function as port P0.</li> <li>• CMOS compatible input level.</li> <li>• CMOS 3-state output structure.</li> </ul>	<ul style="list-style-type: none"> <li>• A-D conversion input pin</li> </ul>	
P80/FLD32– P83/FLD35	I/O port P8	<ul style="list-style-type: none"> <li>• 4-bit I/O port with the same function as port P0.</li> <li>• Low-voltage input level.</li> <li>• High-breakdown-voltage P-channel open-drain output structure.</li> </ul>	<ul style="list-style-type: none"> <li>• FLD automatic display pins</li> </ul>	
P84/FLD36			<ul style="list-style-type: none"> <li>• 4-bit CMOS I/O port with the same function as port P0.</li> <li>• Low-voltage input level.</li> <li>• CMOS 3-state output structure</li> </ul>	<ul style="list-style-type: none"> <li>• FLD automatic display pins</li> <li>• Real time port output</li> </ul>
P85/RTP0/ FLD37, P86/RTP1/ FLD38				<ul style="list-style-type: none"> <li>• FLD automatic display pins</li> <li>• 14-bit PWM output</li> </ul>
P87/PWM0/ FLD39				
P90/XCIN, P91/XCOUT	I/O port P9	<ul style="list-style-type: none"> <li>• 2-bit CMOS I/O port with the same function as port P0.</li> <li>• CMOS compatible input level.</li> <li>• CMOS 3-state output structure.</li> </ul>	<ul style="list-style-type: none"> <li>• I/O pins for sub-clock generating circuit (connect a ceramic resonator or a quartz-crystal oscillator)</li> </ul>	

**PART NUMBERING**

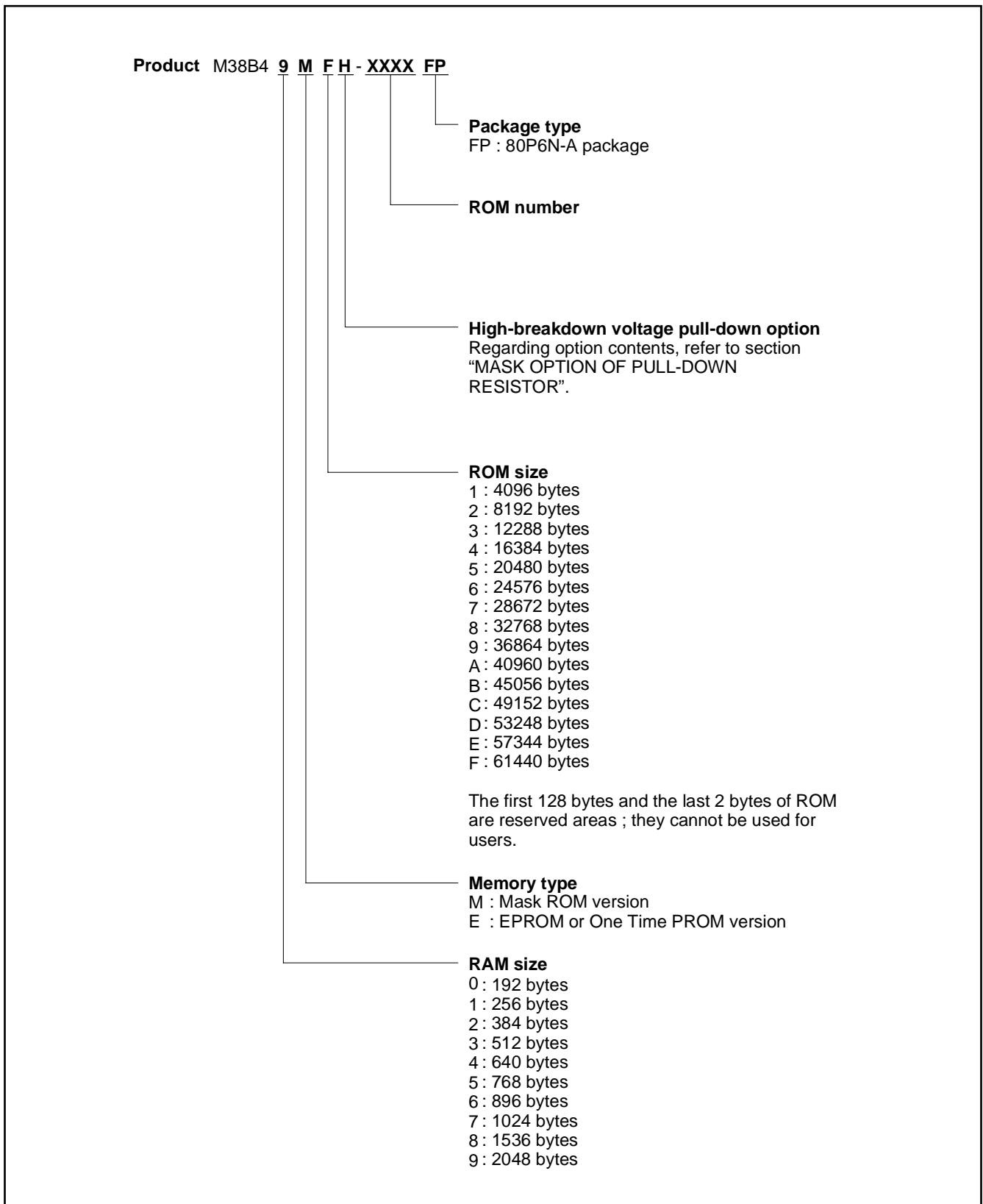

Fig. 3 Part numbering

**GROUP EXPANSION**

Mitsubishi plans to expand the 38B4 group as follows:

**Memory Type**

Support for Mask ROM version.

**Memory Size**

Mask ROM size ..... 48K to 60K bytes

RAM size ..... 1024 to 2048 bytes

**Package**

80P6N-A ..... 0.8 mm-pitch plastic molded QFP

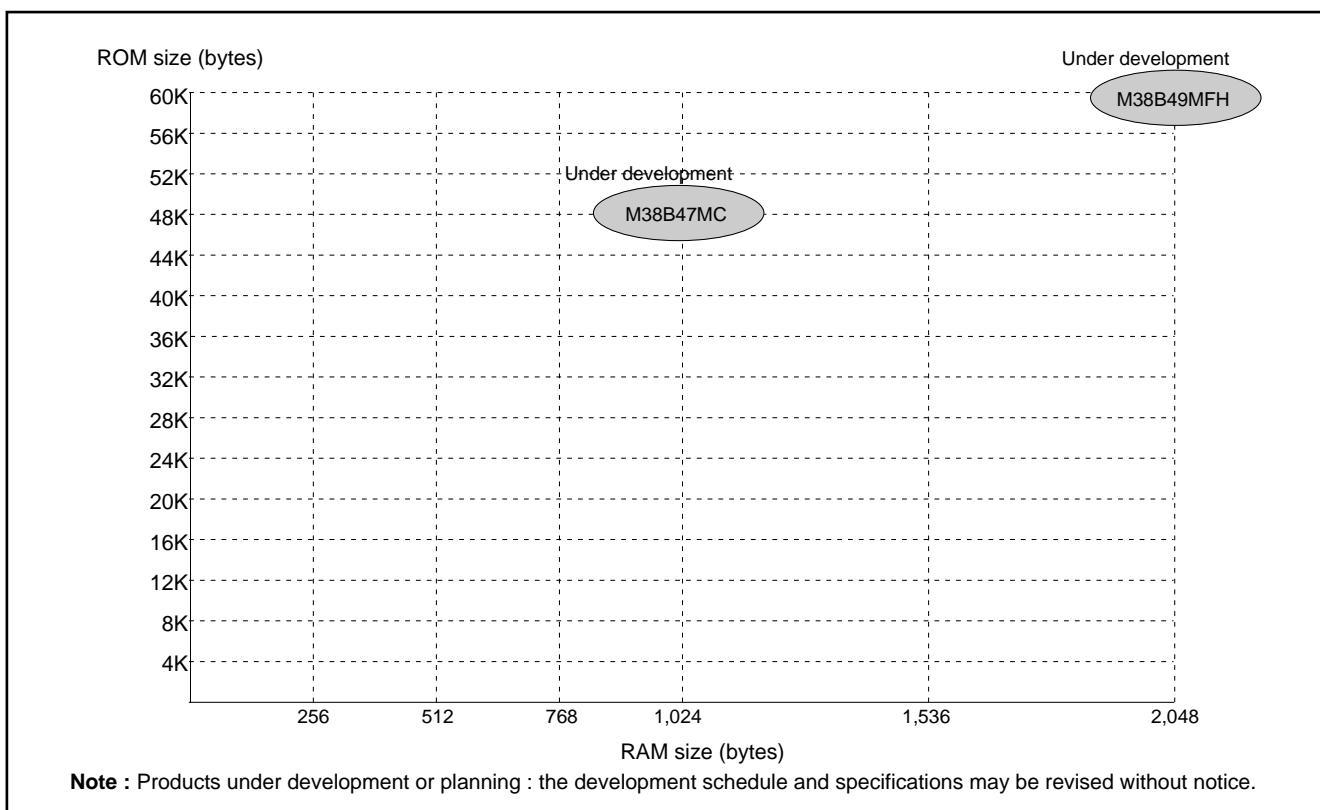

Fig. 4 Memory expansion plan

Currently supported products are listed below.

Table 3 List of supported products

As of Mar. 2000

Product	ROM size (bytes) ROM size for User ( )	RAM size (bytes)	Package	Remarks
M38B49MFH-XXXXFP	61440 (61310)	2048	80P6N-A	Mask ROM version
M38B47MCH-XXXXFP	49152 (49022)	1024	80P6N-A	Mask ROM version

**FUNCTIONAL DESCRIPTION  
Central Processing Unit (CPU)**

The 38B4 group uses the standard 740 Family instruction set. Refer to the table of 740 Family addressing modes and machine instructions or the 740 Family Software Manual for details on the instruction set.

Machine-resident 740 Family instructions are as follows:

- The FST and SLW instructions cannot be used.
- The STP, WIT, MUL, and DIV instructions can be used.

**[Accumulator (A)]**

The accumulator is an 8-bit register. Data operations such as data transfer, etc., are executed mainly through the accumulator.

**[Index Register X (X)]**

The index register X is an 8-bit register. In the index addressing modes, the value of the OPERAND is added to the contents of register X and specifies the real address.

**[Index Register Y (Y)]**

The index register Y is an 8-bit register. In partial instruction, the value of the OPERAND is added to the contents of register Y and specifies the real address.

**[Stack Pointer (S)]**

The stack pointer is an 8-bit register used during subroutine calls and interrupts. This register indicates start address of stored area (stack) for storing registers during subroutine calls and interrupts. The low-order 8 bits of the stack address are determined by the contents of the stack pointer. The high-order 8 bits of the stack address are determined by the stack page selection bit. If the stack page selection bit is "0", the high-order 8 bits becomes "0016". If the stack page selection bit is "1", the high-order 8 bits becomes "0116".

The operations of pushing register contents onto the stack and popping them from the stack are shown in Figure 6.

Store registers other than those described in Figure 6 with program when the user needs them during interrupts or subroutine calls (see Table 4).

**[Program Counter (PC)]**

The program counter is a 16-bit counter consisting of two 8-bit registers PCH and PCL. It is used to indicate the address of the next instruction to be executed.

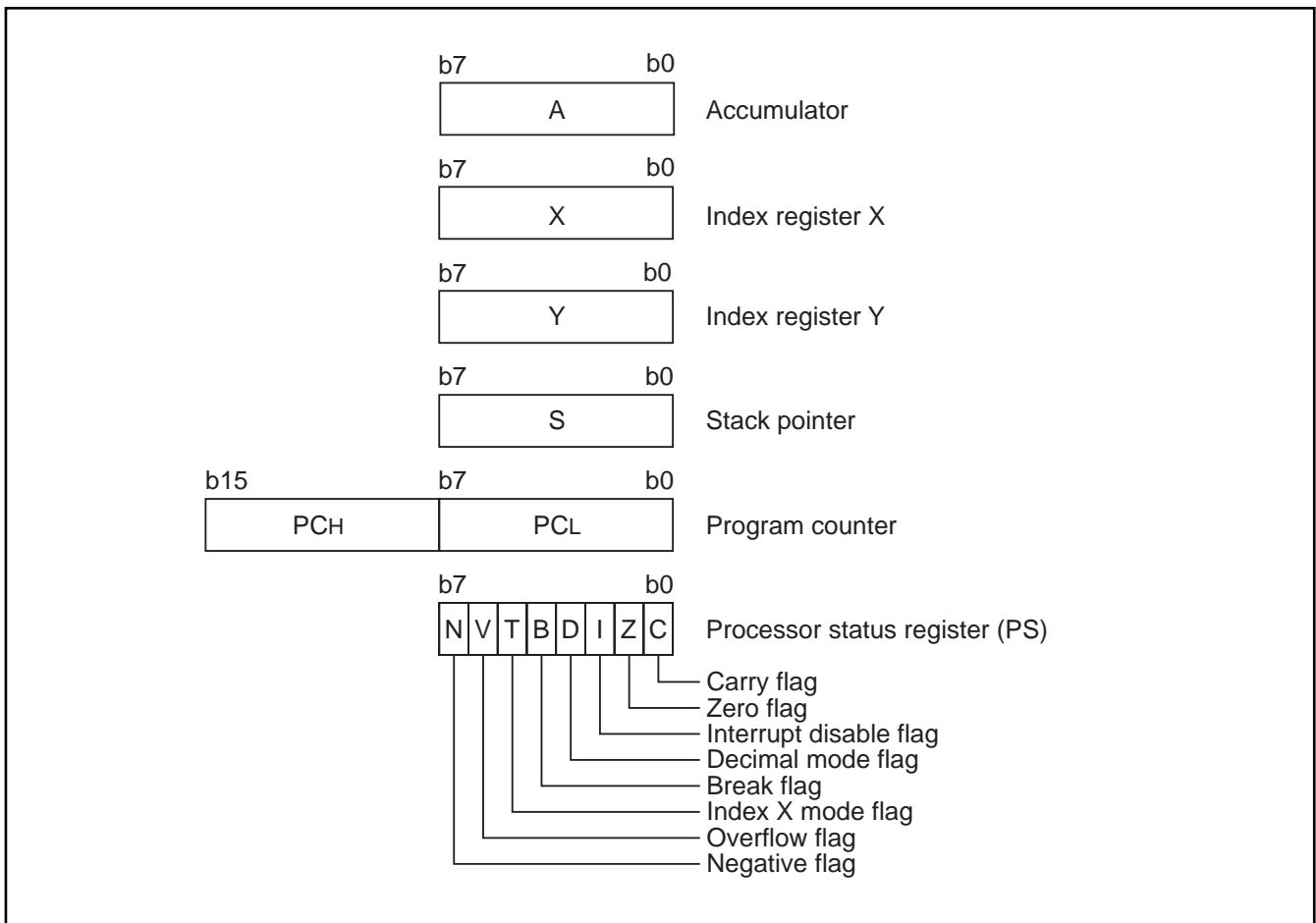

Fig. 5 740 Family CPU register structure

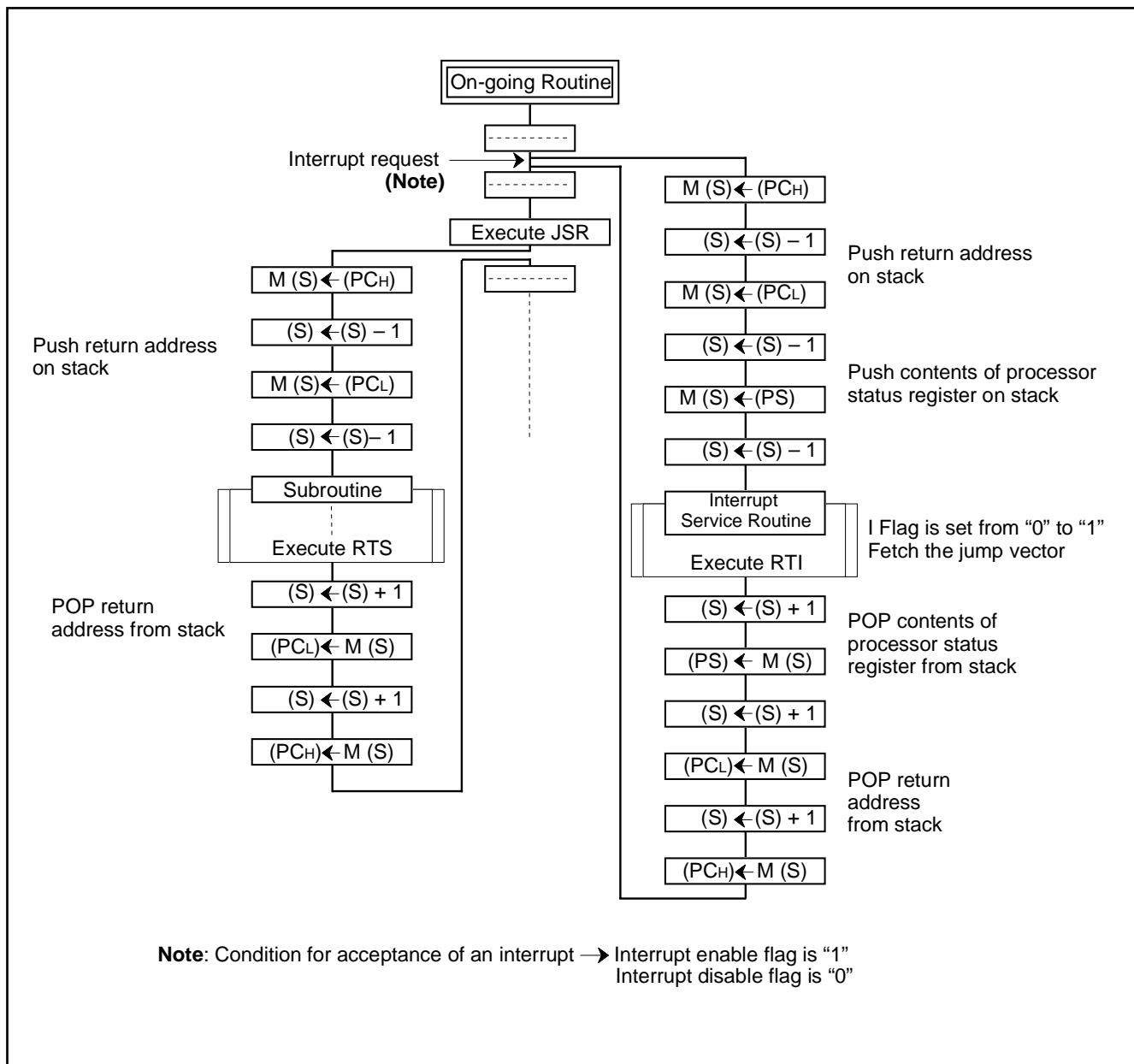

Fig. 6 Register push and pop at interrupt generation and subroutine call

Table 4 Push and pop instructions of accumulator or processor status register

	Push instruction to stack	Pop instruction from stack
Accumulator	PHA	PLA
Processor status register	PHP	PLP



**[Processor Status Register (PS)]**

The processor status register is an 8-bit register consisting of 5 flags which indicate the status of the processor after an arithmetic operation and 3 flags which decide MCU operation. Branch operations can be performed by testing the Carry (C) flag, Zero (Z) flag, Overflow (V) flag, or the Negative (N) flag. In decimal mode, the Z, V, N flags are not valid.

•Bit 0: Carry flag (C)

The C flag contains a carry or borrow generated by the arithmetic logic unit (ALU) immediately after an arithmetic operation. It can also be changed by a shift or rotate instruction.

•Bit 1: Zero flag (Z)

The Z flag is set if the result of an immediate arithmetic operation or a data transfer is "0", and cleared if the result is anything other than "0".

•Bit 2: Interrupt disable flag (I)

The I flag disables all interrupts except for the interrupt generated by the BRK instruction.

Interrupts are disabled when the I flag is "1".

•Bit 3: Decimal mode flag (D)

The D flag determines whether additions and subtractions are executed in binary or decimal. Binary arithmetic is executed when this flag is "0"; decimal arithmetic is executed when it is "1". Decimal correction is automatic in decimal mode. Only the ADC and SBC instructions can be used for decimal arithmetic.

•Bit 4: Break flag (B)

The B flag is used to indicate that the current interrupt was generated by the BRK instruction. The BRK flag in the processor status register is always "0". When the BRK instruction is used to generate an interrupt, the processor status register is pushed onto the stack with the break flag set to "1".

•Bit 5: Index X mode flag (T)

When the T flag is "0", arithmetic operations are performed between accumulator and memory. When the T flag is "1", direct arithmetic operations and direct data transfers are enabled between memory locations.

•Bit 6: Overflow flag (V)

The V flag is used during the addition or subtraction of one byte of signed data. It is set if the result exceeds +127 to -128. When the BIT instruction is executed, bit 6 of the memory location operated on by the BIT instruction is stored in the overflow flag.

•Bit 7: Negative flag (N)

The N flag is set if the result of an arithmetic operation or data transfer is negative. When the BIT instruction is executed, bit 7 of the memory location operated on by the BIT instruction is stored in the negative flag.

**Table 5 Set and clear instructions of each bit of processor status register**

	C flag	Z flag	I flag	D flag	B flag	T flag	V flag	N flag
Set instruction	SEC	–	SEI	SED	–	SET	–	–
Clear instruction	CLC	–	CLI	CLD	–	CLT	CLV	–

**[CPU Mode Register (CPUM)] 003B16**

The CPU mode register contains the stack page selection bit and the internal system clock selection bit etc.

The CPU mode register is allocated at address 003B16.

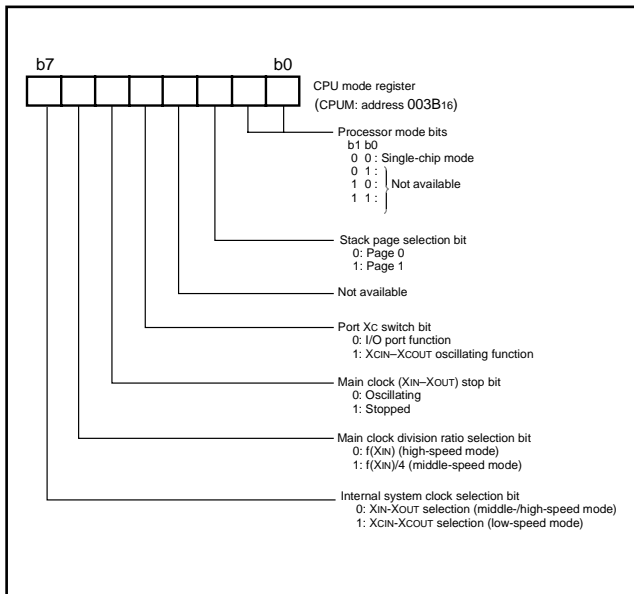

Fig. 7 Structure of CPU mode register

**MEMORY**

**Special Function Register (SFR) Area**

The special function register (SFR) area in the zero page contains control registers such as I/O ports and timers.

**RAM**

RAM is used for data storage and for stack area of subroutine calls and interrupts.

**ROM**

The first 128 bytes and the last 2 bytes of ROM are reserved for device testing, and the other areas are user areas for storing programs.

**Interrupt Vector Area**

The interrupt vector area contains reset and interrupt vectors.

**Zero Page**

The 256 bytes from addresses 0000<sub>16</sub> to 00FF<sub>16</sub> are called the zero page area. The internal RAM and the special function registers (SFR) are allocated to this area.

The zero page addressing mode can be used to specify memory and register addresses in the zero page area. Access to this area with only 2 bytes is possible in the zero page addressing mode.

**Special Page**

The 256 bytes from addresses FF00<sub>16</sub> to FFFF<sub>16</sub> are called the special page area. The special page addressing mode can be used to specify memory addresses in the special page area. Access to this area with only 2 bytes is possible in the special page addressing mode.

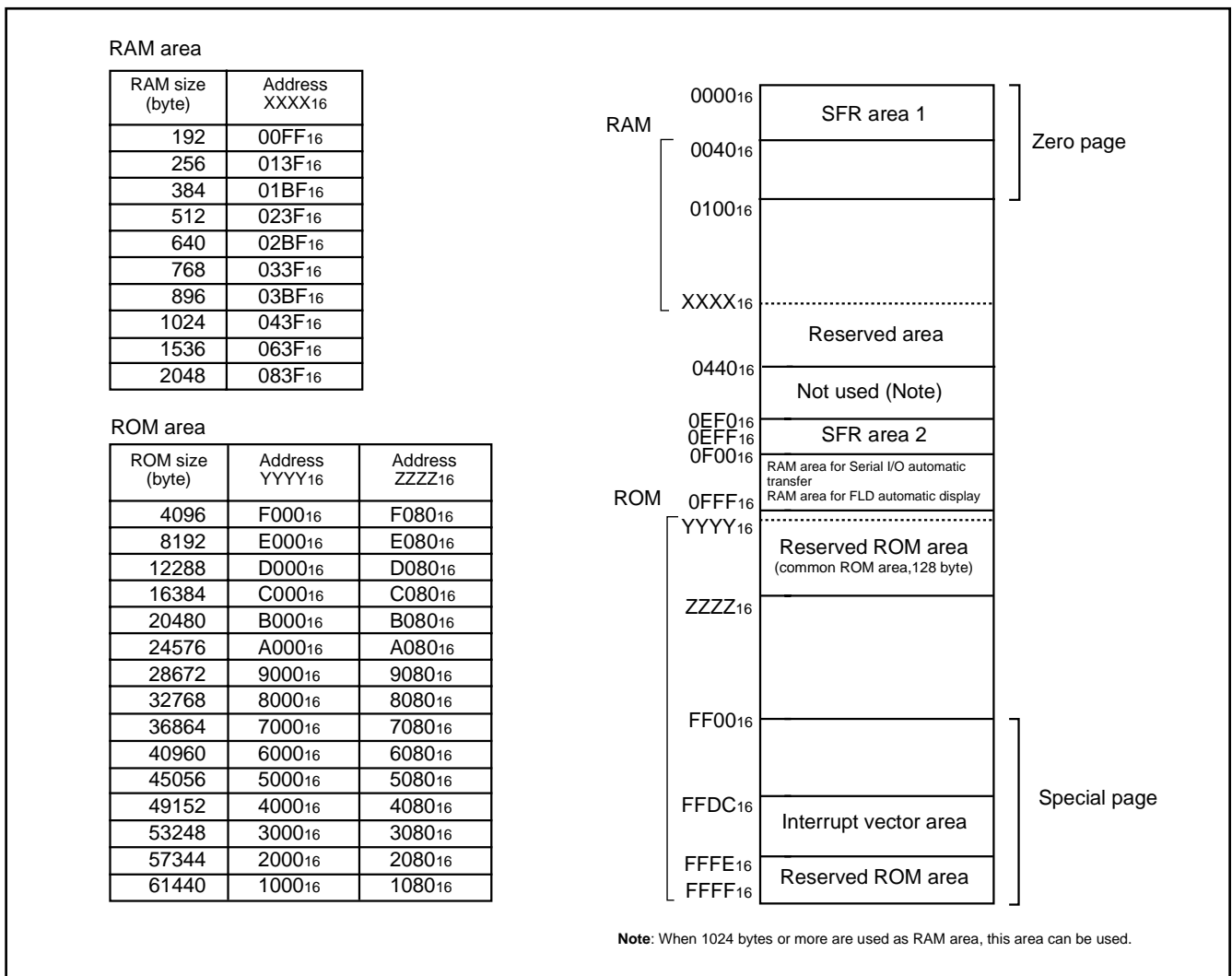

Fig. 8 Memory map diagram

0000 <sub>16</sub>	Port P0 (P0)	0020 <sub>16</sub>	Timer 1 (T1)
0001 <sub>16</sub>	Port P0 direction register (P0D)	0021 <sub>16</sub>	Timer 2 (T2)
0002 <sub>16</sub>	Port P1 (P1)	0022 <sub>16</sub>	Timer 3 (T3)
0003 <sub>16</sub>		0023 <sub>16</sub>	Timer 4 (T4)
0004 <sub>16</sub>	Port P2 (P2)	0024 <sub>16</sub>	Timer 5 (T5)
0005 <sub>16</sub>	Port P2 direction register (P2D)	0025 <sub>16</sub>	Timer 6 (T6)
0006 <sub>16</sub>	Port P3 (P3)	0026 <sub>16</sub>	PWM control register (PWMCON)
0007 <sub>16</sub>		0027 <sub>16</sub>	Timer 6 PWM register (T6PWM)
0008 <sub>16</sub>	Port P4 (P4)	0028 <sub>16</sub>	Timer 12 mode register (T12M)
0009 <sub>16</sub>	Port P4 direction register (P4D)	0029 <sub>16</sub>	Timer 34 mode register (T34M)
000A <sub>16</sub>	Port P5 (P5)	002A <sub>16</sub>	Timer 56 mode register (T56M)
000B <sub>16</sub>	Port P5 direction register (P5D)	002B <sub>16</sub>	Watchdog timer control register (WDTCON)
000C <sub>16</sub>	Port P6 (P6)	002C <sub>16</sub>	Timer X (low-order) (TXL)
000D <sub>16</sub>	Port P6 direction register (P6D)	002D <sub>16</sub>	Timer X (high-order) (TXH)
000E <sub>16</sub>	Port P7 (P7)	002E <sub>16</sub>	Timer X mode register 1 (TXM1)
000F <sub>16</sub>	Port P7 direction register (P7D)	002F <sub>16</sub>	Timer X mode register 2 (TXM2)
0010 <sub>16</sub>	Port P8 (P8)	0030 <sub>16</sub>	Interrupt interval determination register (IID)
0011 <sub>16</sub>	Port P8 direction register (P8D)	0031 <sub>16</sub>	Interrupt interval determination control register (IIDCON)
0012 <sub>16</sub>	Port P9 (P9)	0032 <sub>16</sub>	A-D control register (ADCON)
0013 <sub>16</sub>	Port P9 direction register (P9D)	0033 <sub>16</sub>	A-D conversion register (low-order) (ADL)
0014 <sub>16</sub>	PWM register (high-order) (PWMH)	0034 <sub>16</sub>	A-D conversion register (high-order) (ADH)
0015 <sub>16</sub>	PWM register (low-order) (PWM L)	0035 <sub>16</sub>	
0016 <sub>16</sub>	Baud rate generator (BRG)	0036 <sub>16</sub>	
0017 <sub>16</sub>	UART control register (UARTCON)	0037 <sub>16</sub>	
0018 <sub>16</sub>	Serial I/O1 automatic transfer data pointer (SIO1DP)	0038 <sub>16</sub>	
0019 <sub>16</sub>	Serial I/O1 control register 1 (SIO1CON1)	0039 <sub>16</sub>	Interrupt source switch register (IFR)
001A <sub>16</sub>	Serial I/O1 control register 2 (SIO1CON2)	003A <sub>16</sub>	Interrupt edge selection register (INTEDGE)
001B <sub>16</sub>	Serial I/O1 register/Transfer counter (SIO1)	003B <sub>16</sub>	CPU mode register (CPUM)
001C <sub>16</sub>	Serial I/O1 control register 3 (SIO1CON3)	003C <sub>16</sub>	Interrupt request register 1 (IREQ1)
001D <sub>16</sub>	Serial I/O2 control register (SIO2CON)	003D <sub>16</sub>	Interrupt request register 2 (IREQ2)
001E <sub>16</sub>	Serial I/O2 status register (SIO2STS)	003E <sub>16</sub>	Interrupt control register 1 (ICON1)
001F <sub>16</sub>	Serial I/O2 transmit/receive buffer register (TB/RB)	003F <sub>16</sub>	Interrupt control register 2 (ICON2)
0EF0 <sub>16</sub>	Pull-up control register 1 (PULL1)	0EF8 <sub>16</sub>	FLD data pointer (FLDDP)
0EF1 <sub>16</sub>	Pull-up control register 2 (PULL2)	0EF9 <sub>16</sub>	Port P0FLD/port switch register (P0FPR)
0EF2 <sub>16</sub>		0EFA <sub>16</sub>	Port P2FLD/port switch register (P2FPR)
0EF3 <sub>16</sub>		0EFB <sub>16</sub>	Port P8FLD/port switch register (P8FPR)
0EF4 <sub>16</sub>	FLDC mode register (FLDM)	0EFC <sub>16</sub>	Port P8FLD output control register (P8FLDCON)
0EF5 <sub>16</sub>	Tdisp time set register (TDISP)	0EFD <sub>16</sub>	Buzzer output control register (BUZCON)
0EF6 <sub>16</sub>	Toff1 time set register (TOFF1)	0EFE <sub>16</sub>	
0EF7 <sub>16</sub>	Toff2 time set register (TOFF2)	0EFF <sub>16</sub>	

Fig. 9 Memory map of special function register (SFR)

**I/O PORTS**

**[Direction Registers] PiD**

The 38B4 group has 51 programmable I/O pins arranged in eight individual I/O ports (P0, P2, P4<sub>0</sub>–P4<sub>6</sub>, and P5–P9). The I/O ports have direction registers which determine the input/output direction of each individual pin. Each bit in a direction register corresponds to one pin, and each pin can be set to be input port or output port. When “0” is written to the bit corresponding to a pin, that pin becomes an input pin. When “1” is written to that pin, that pin becomes an output pin. If data is read from a pin set to output, the value of the port output latch is read, not the value of the pin itself. Pins set to input (the bit corresponding to that pin must be set to “0”) are floating and the value of that pin can be read. If a pin set to input is written to, only the port output latch is written to and the pin remains floating.

**[High-Breakdown-Voltage Output Ports]**

The 38B4 group has 5 ports with high-breakdown-voltage pins (ports P0–P3 and P8<sub>0</sub>–P8<sub>3</sub>). The high-breakdown-voltage ports have P-channel open-drain output with V<sub>cc</sub>- 45 V of breakdown voltage. Each pin in ports P0, P1, and P3 has an internal pull-down resistor connected to V<sub>EE</sub>. At reset, the P-channel output transistor of each port latch is turned off, so that it goes to V<sub>EE</sub> level (“L”) by the pull-down resistor.

Writing “1” (weak drivability) to bit 7 of the FLDC mode register (address 0EF4<sub>16</sub>) shows the rising transition of the output transistors for reducing transient noise. At reset, bit 7 of the FLDC mode register is set to “0” (strong drivability).

**[Pull-up Control Register] PULL**

Ports P5, P6<sub>1</sub>–P6<sub>5</sub>, P7, P8<sub>4</sub>–P8<sub>7</sub> and P9 have built-in programmable pull-up resistors. The pull-up resistors are valid only in the case that the each control bit is set to “1” and the corresponding port direction registers are set to input mode.

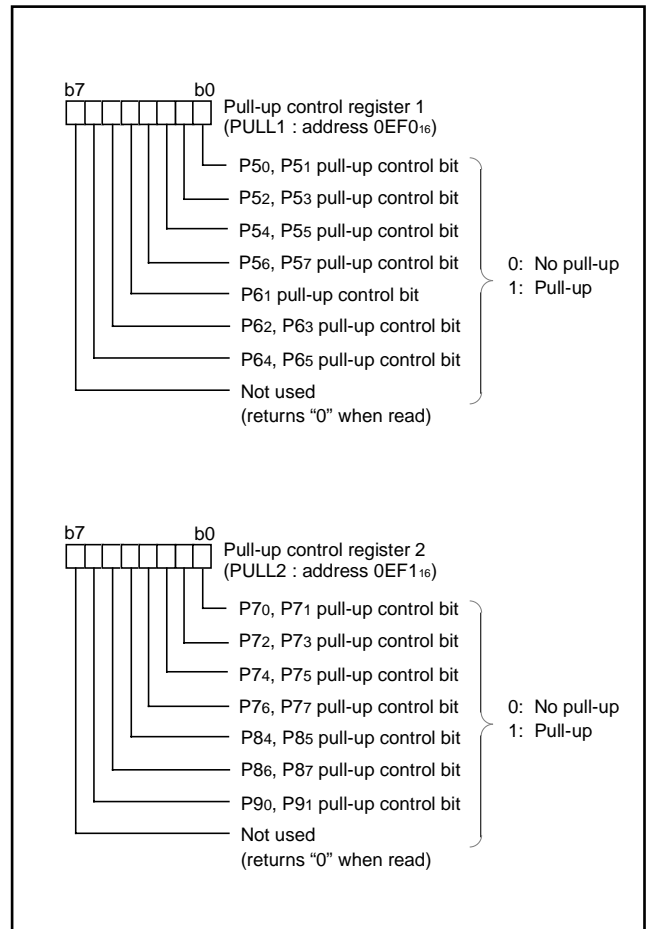

**Fig. 10 Structure of pull-up control registers (PULL1 and PULL2)**

Table 6 List of I/O port functions (1)

zPin	Name	Input/Output	I/O Format	Non-Port Function	Related SFRs	Ref.No.	
P00/FLD8– P07/FLD15	Port P0	Input/output, individual bits	CMOS compatible input level High-breakdown voltage P- channel open-drain output with pull-down resistor	FLD automatic display function	FLDC mode register Port P0FLD/port switch register	(1)	
P10/FLD16– P17/FLD23	Port P1	Output	High-breakdown voltage P- channel open-drain output with pull-down resistor		FLDC mode register	(2)	
P20/BUZ02/ FLD0	Port P2	Input/output, individual bits	Low-voltage input level High-breakdown voltage P- channel open-drain output	Buzzer output (P20)	FLDC mode register Port P2FLD/port switch register	(3)	
P21/FLD1– P27/FLD7				FLD automatic display function			Buzzer output control register
P30/FLD24– P37/FLD31	Port P3	Output	High-breakdown voltage P- channel open-drain output with pull-down resistor		FLDC mode register	(2)	
P40/INT0, P41/INT1	Port P4	Input/output, individual bits	CMOS compatible input level N-channel open-drain output	External interrupt input	Interrupt edge selection register	(5)	
P42/INT3				In the mask option type P, INT3 cannot be used.			(7-1) (7-2)
P43/BUZ01				Buzzer output		Buzzer output control register	(4)
P44/PWM1				PWM output		Timer 56 mode register	(6)
P45/T1OUT				Timer output		Timer 12 mode register	(8-1)
P46/T3OUT				Timer output		Timer 34 mode register	(8-2)
P47/INT2				Input		CMOS compatible input level	External interrupt input
P50/SIN1	Port P5	Input/output, individual bits	CMOS compatible input level CMOS 3-state output	Serial I/O1 function I/O	Serial I/O1 control register 1, 2	(10)	
P51/SOUT1, P52/SCLK11, P53/SCLK12						(11)	
P54/RxD				Serial I/O2 function I/O	Serial I/O2 control register UART control register	(10)	
P55/TxD, P56/SCLK21						(11)	
P57/SRDY2/ SCLK22					(12)		
P60/CNTR1				Port P6		CMOS compatible input level N-channel open-drain output CMOS compatible input level CMOS 3-state output	External count input
P61/CNTR0/ CNTR2	In the mask option type P, CNTR1 cannot be used.	(7-2)					
P62/SRDY1/ AN8		(13)					
P63/AN9	Serial I/O1 function I/O	Serial I/O1 control register 1, 2 A-D control register	(14)				
P64/INT4/ SBUSY1/AN10	A-D conversion input		A-D control register				(15)
P65/SSTB1/ AN11	Dimmer signal output	P8FLD output control bit					
	Serial I/O1 function I/O	Serial I/O1 control register 1, 2 A-D control register	(16)				
P70/AN0– P77/AN7	Port P7						A-D conversion input
		External interrupt input		A-D control register	(15)		

Table 7 List of I/O port functions (2)

Pin	Name	Input/Output	I/O Format	Non-Port Function	Related SFRs	Ref.No.
P80/FLD32– P83/FLD35	Port P8	Input/output, individual bits	Low-voltage input level High-breakdown voltage P- channel open-drain output	FLD automatic display function	FLDC mode register Port P8FLD/port switch register	(1)
P84/FLD36			Low-voltage input level			(18)
P85/RTP0/ FLD37, P86/RTP1/ FLD38			CMOS 3-state output	FLD automatic display function Real time port output	FLDC mode register Port P8FLD/port switch register Timer X mode register 2	(19)
P87/PWM0/ FLD39				FLD automatic display function PWM output	FLDC mode register Port P8FLD/port switch register PWM control register	(20)
P90/XCIN P91/XCOUT			Port P9		CMOS compatible input level CMOS 3-state output	Sub-clock generating circuit I/O
				(22)		

**Notes 1 :** Make sure that the input level at each pin is either 0 V or Vcc during execution of the STP instruction.

When an input level is at an intermediate potential, a current will flow from Vcc to Vss through the input-stage gate.

**2 :** How to use double-function ports as function I/O ports, refer to the applicable sections.

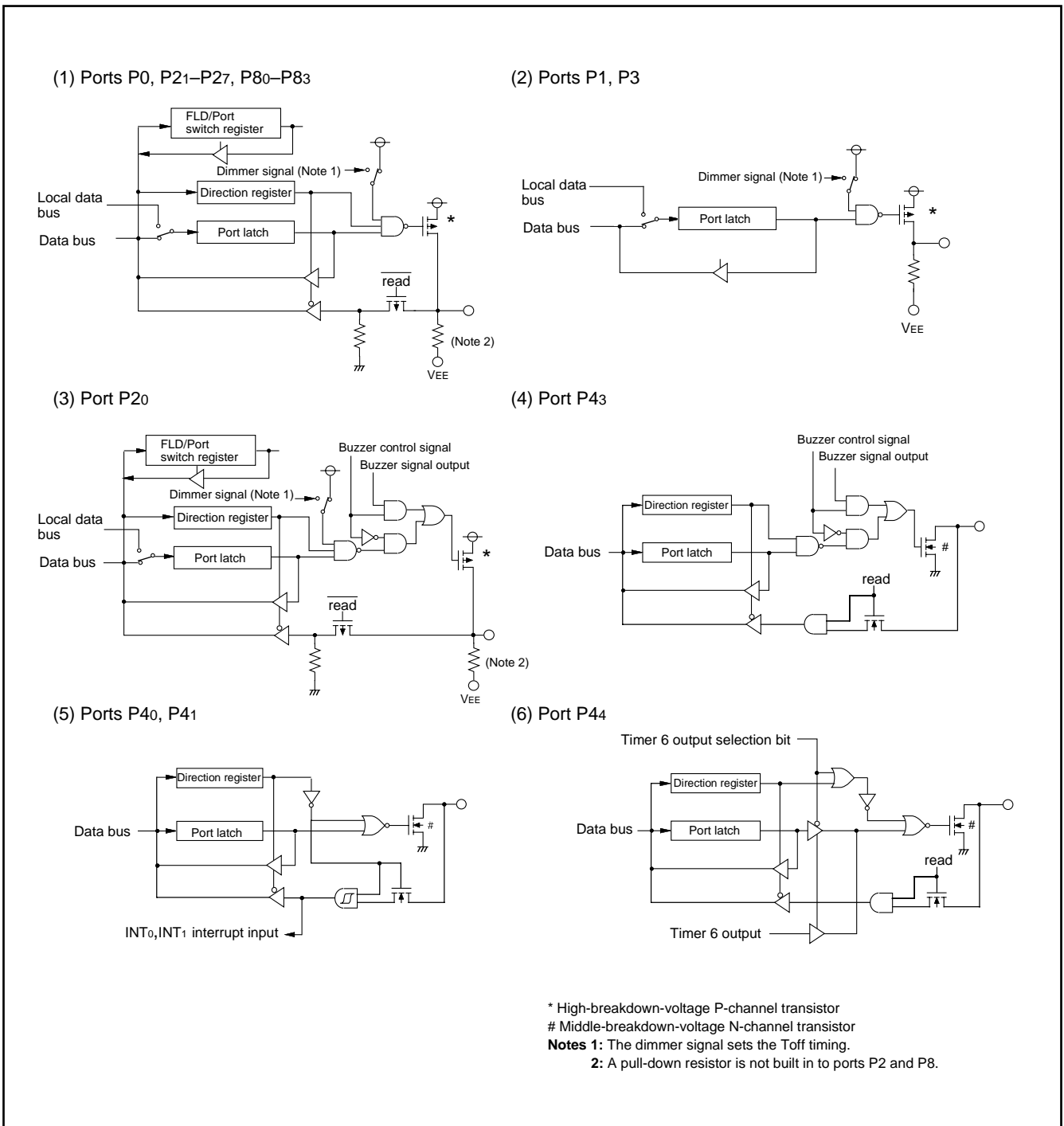
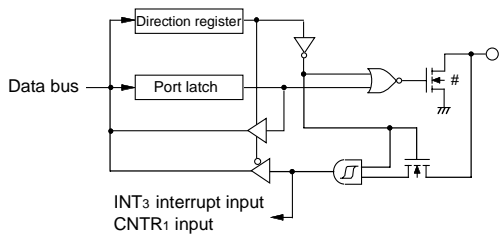

Fig. 11 Port block diagram (1)



(7-1) Ports P42, P60



(7-2) Ports P42, P60 (mask option type P)

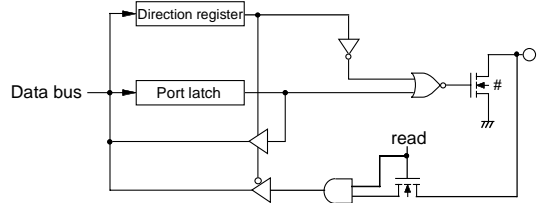

(8-1) Ports P45, P46

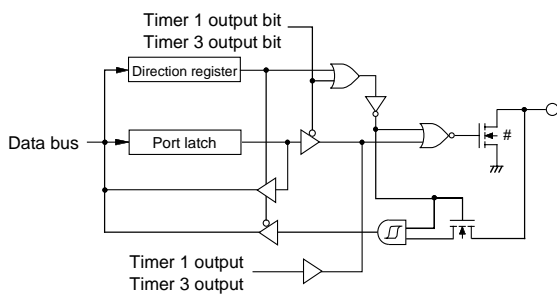

(8-2) Ports P45, P46 (mask option type P)

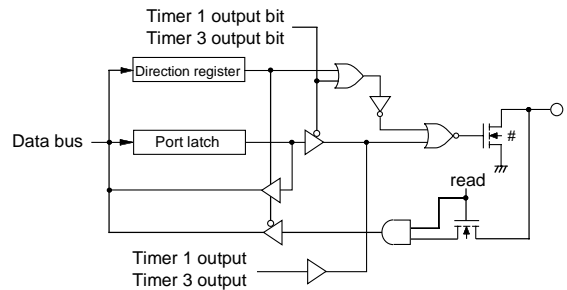

(9) Port P47

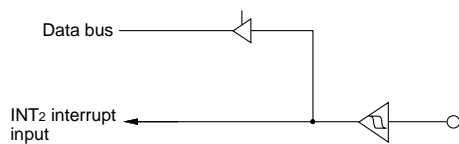

(10) Ports P50, P54

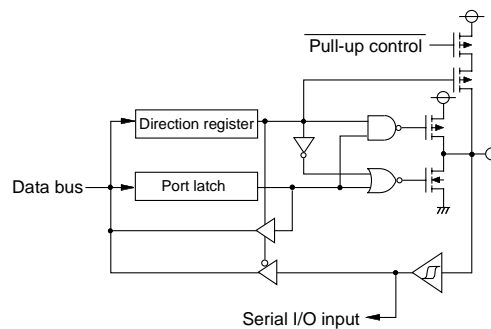

# Middle-breakdown-voltage N-channel transistor

Fig. 12 Port block diagram (2)

(11) Ports P51–P53, P55, P56

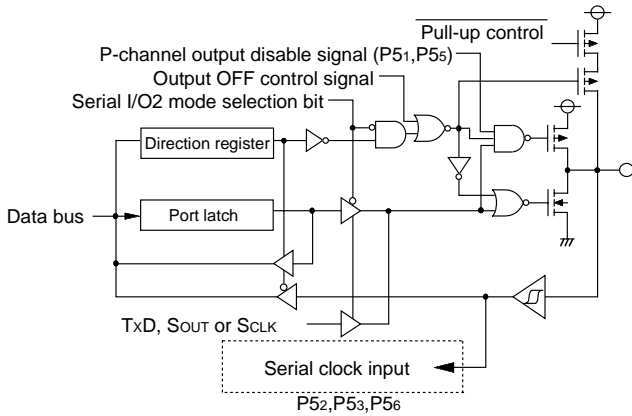

(12) Port P57

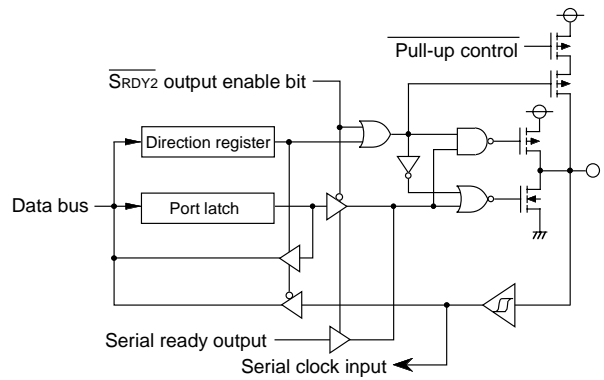

(13) Port P61

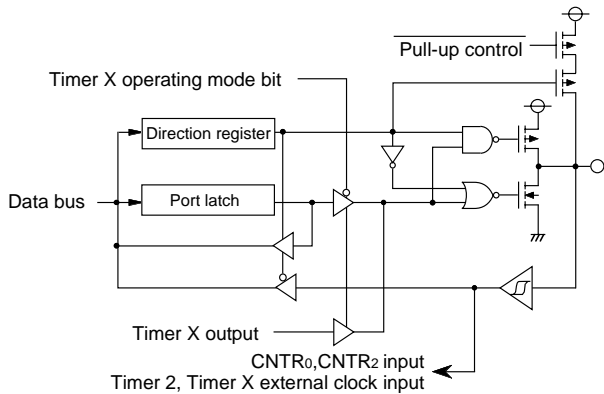

(14) Port P62

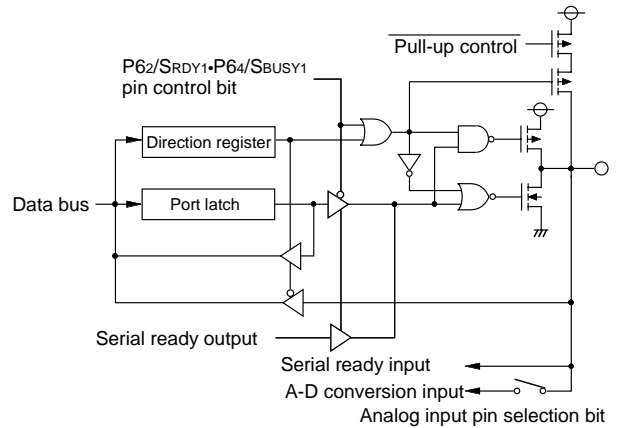

(15) Ports P63, P7

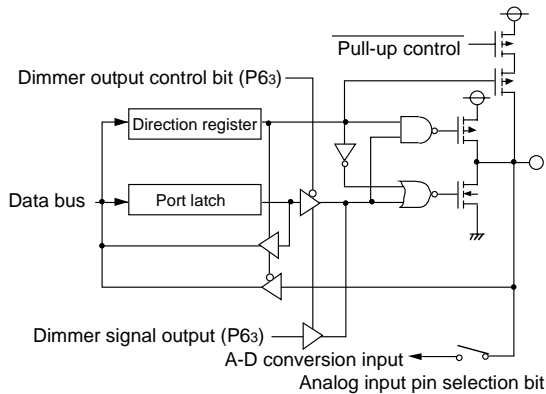

(16) Port P64

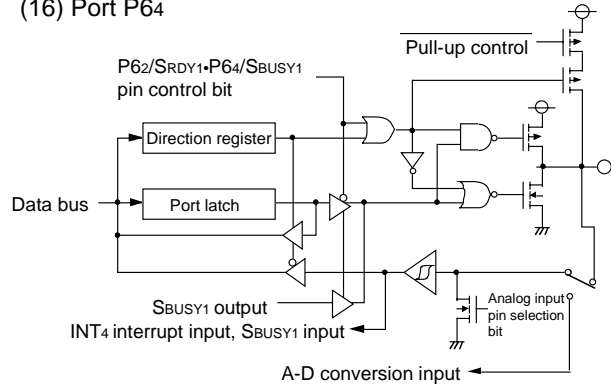

Fig. 13 Port block diagram (3)

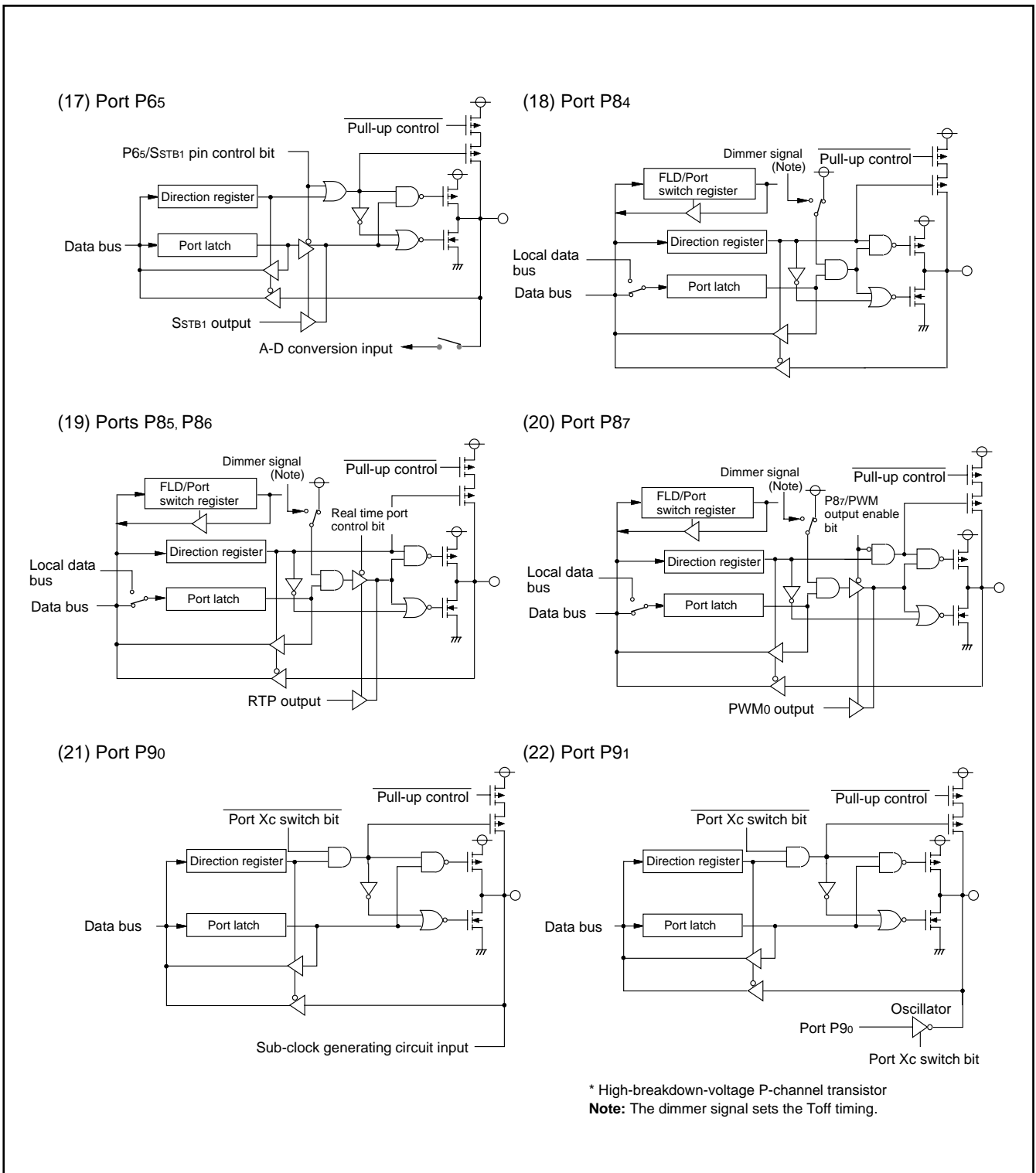

Fig. 14 Port block diagram (4)

## INTERRUPTS

Interrupts occur by twenty one sources: five external, fifteen internal, and one software.

### Interrupt Control

Each interrupt except the BRK instruction interrupt have both an interrupt request bit and an interrupt enable bit, and is controlled by the interrupt disable flag. An interrupt occurs if the corresponding interrupt request and enable bits are "1" and the interrupt disable flag is "0". Interrupt enable bits can be set or cleared by software. Interrupt request bits can be cleared by software, but cannot be set by software. The BRK instruction interrupt and reset cannot be disabled with any flag or bit. The I flag disables all interrupts except the BRK instruction interrupt and reset. If several interrupts requests occurs at the same time the interrupt with highest priority is accepted first.

### Interrupt Operation

Upon acceptance of an interrupt the following operations are automatically performed:

1. The contents of the program counter and processor status register are automatically pushed onto the stack.
2. The interrupt disable flag is set and the corresponding interrupt request bit is cleared.
3. The interrupt jump destination address is read from the vector table into the program counter.

### ■Notes on Use

When the active edge of an external interrupt (INT<sub>0</sub>–INT<sub>4</sub>) is set or when switching interrupt sources in the same vector address, the corresponding interrupt request bit may also be set. Therefore, please take following sequence:

- (1) Disable the external interrupt which is selected.
- (2) Change the active edge in interrupt edge selection register
- (3) Clear the set interrupt request bit to "0".
- (4) Enable the external interrupt which is selected.

Table 8 Interrupt vector addresses and priority

Interrupt Source	Priority	Vector Addresses (Note 1)		Interrupt Request Generating Conditions	Remarks
		High	Low		
Reset (Note 2)	1	FFFD <sub>16</sub>	FFFC <sub>16</sub>	At reset	Non-maskable
INT <sub>0</sub>	2	FFFB <sub>16</sub>	FFFA <sub>16</sub>	At detection of either rising or falling edge of INT <sub>0</sub> input	External interrupt (active edge selectable)
INT <sub>1</sub>	3	FFF9 <sub>16</sub>	FFF8 <sub>16</sub>	At detection of either rising or falling edge of INT <sub>1</sub> input	External interrupt (active edge selectable)
INT <sub>2</sub>	4	FFF7 <sub>16</sub>	FFF6 <sub>16</sub>	At detection of either rising or falling edge of INT <sub>2</sub> input	External interrupt (active edge selectable)
Remote control/ counter overflow				At 8-bit counter overflow	Valid when interrupt interval determination is operating
Serial I/O1	5	FFF5 <sub>16</sub>	FFF4 <sub>16</sub>	At completion of data transfer	Valid when serial I/O ordinary mode is selected
Serial I/O auto- automatic transfer				At completion of the last data transfer	Valid when serial I/O automatic transfer mode is selected
Timer X	6	FFF3 <sub>16</sub>	FFF2 <sub>16</sub>	At timer X underflow	
Timer 1	7	FFF1 <sub>16</sub>	FFF0 <sub>16</sub>	At timer 1 underflow	
Timer 2	8	FFEF <sub>16</sub>	FFEE <sub>16</sub>	At timer 2 underflow	STP release timer underflow
Timer 3	9	FFED <sub>16</sub>	FFEC <sub>16</sub>	At timer 3 underflow	
Timer 4	10	FFEB <sub>16</sub>	FFEA <sub>16</sub>	At timer 4 underflow	(Note 3)
Timer 5	11	FFE9 <sub>16</sub>	FFE8 <sub>16</sub>	At timer 5 underflow	
Timer 6	12	FFE7 <sub>16</sub>	FFE6 <sub>16</sub>	At timer 6 underflow	
Serial I/O2 receive	13	FFE5 <sub>16</sub>	FFE4 <sub>16</sub>	At completion of serial I/O2 data receive	
INT <sub>3</sub>	14	FFE3 <sub>16</sub>	FFE2 <sub>16</sub>	At detection of either rising or falling edge of INT <sub>3</sub> input	External interrupt (Note 4) (active edge selectable)
Serial I/O2 transmit				At completion of serial I/O2 data transmit	
INT <sub>4</sub>	15	FFE1 <sub>16</sub>	FFE0 <sub>16</sub>	At detection of either rising or falling edge of INT <sub>4</sub> input	External interrupt (active edge selectable) Valid when INT <sub>4</sub> interrupt is selected
A-D conversion				At completion of A-D conversion	Valid when A-D conversion is selected
FLD blanking	16	FFDF <sub>16</sub>	FFDE <sub>16</sub>	At falling edge of the last timing immediately before blanking period starts	Valid when FLD blanking interrupt is selected
FLD digit				At rising edge of digit (each timing)	Valid when FLD digit interrupt is selected
BRK instruction	17	FFDD <sub>16</sub>	FFDC <sub>16</sub>	At BRK instruction execution	Non-maskable software interrupt

Notes 1 : Vector addresses contain interrupt jump destination addresses.

2 : Reset function in the same way as an interrupt with the highest priority.

3 : In the mask option type P, timer 4 interrupt whose count source is CNTR<sub>1</sub> input cannot be used.

4 : In the mask option type P, INT<sub>3</sub> interrupt cannot be used.

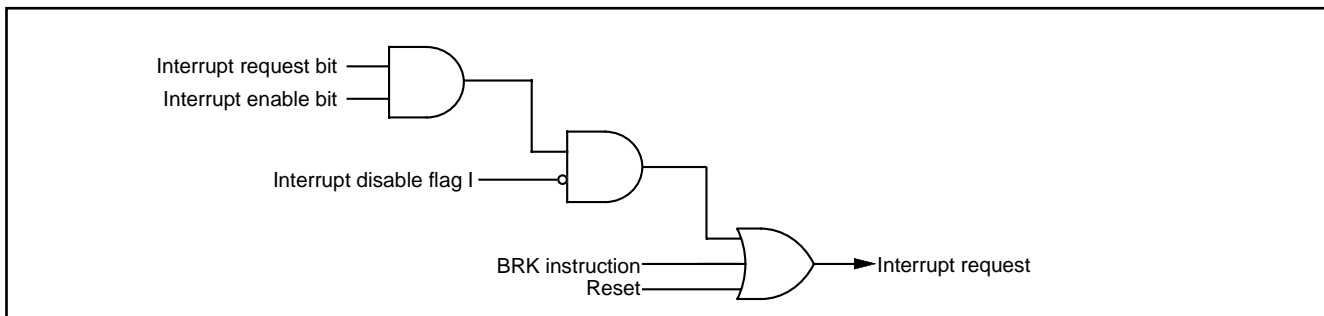

Fig. 15 Interrupt control

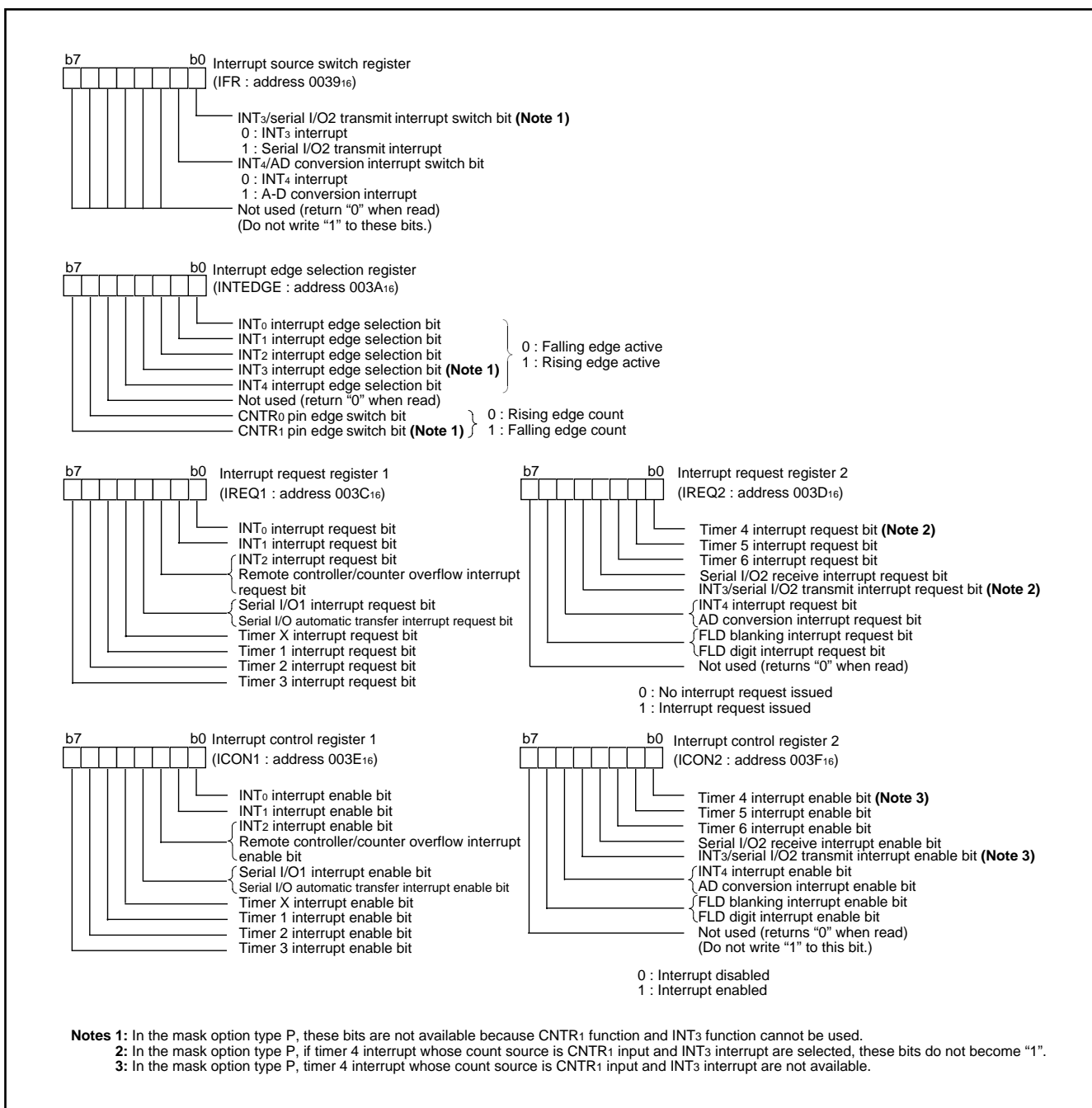

Fig. 16 Structure of interrupt related registers

**TIMERS**

**8-Bit Timer**

The 38B4 group has six built-in timers : Timer 1, Timer 2, Timer 3, Timer 4, Timer 5, and Timer 6.

Each timer has the 8-bit timer latch. All timers are down-counters. When the timer reaches "00<sub>16</sub>", an underflow occurs with the next count pulse. Then the contents of the timer latch is reloaded into the timer and the timer continues down-counting. When a timer underflows, the interrupt request bit corresponding to that timer is set to "1".

The count can be stopped by setting the stop bit of each timer to "1". The internal system clock can be set to either the high-speed mode or low-speed mode with the CPU mode register. At the same time, timer internal count source is switched to either f(X<sub>IN</sub>) or f(X<sub>CIN</sub>).

●**Timer 1, Timer 2**

The count sources of timer 1 and timer 2 can be selected by setting the timer 12 mode register. A rectangular waveform of timer 1 underflow signal divided by 2 can be output from the P4<sub>5</sub>/T1<sub>OUT</sub> pin. The active edge of the external clock CNTR<sub>0</sub> can be switched with the bit 6 of the interrupt edge selection register.

At reset or when executing the STP instruction, all bits of the timer 12 mode register are cleared to "0", timer 1 is set to "FF<sub>16</sub>", and timer 2 is set to "01<sub>16</sub>".

●**Timer 3, Timer 4**

The count sources of timer 3 and timer 4 can be selected by setting the timer 34 mode register. A rectangular waveform of timer 3 underflow signal divided by 2 can be output from the P4<sub>6</sub>/T3<sub>OUT</sub> pin. The active edge of the external clock CNTR<sub>1</sub> (**Note**) can be switched with the bit 7 of the interrupt edge selection register.

**Note:** In the mask option type P, CNTR<sub>1</sub> function cannot be used.

●**Timer 5, Timer 6**

The count sources of timer 5 and timer 6 can be selected by setting the timer 56 mode register. A rectangular waveform of timer 6 underflow signal divided by 2 can be output from the P4<sub>4</sub>/PWM<sub>1</sub> pin.

**(1) Timer 6 PWM<sub>1</sub> mode**

Timer 6 can output a PWM rectangular waveform with "H" duty cycle n/(n+m) from the P4<sub>4</sub>/PWM<sub>1</sub> pin by setting the timer 56 mode register (refer to Figure 19). The n is the value set in timer 6 latch (address 0025<sub>16</sub>) and m is the value in the timer 6 PWM register (address 0027<sub>16</sub>). If n is "0", the PWM output is "L", if m is "0", the PWM output is "H" (n = 0 is prior than m = 0). In the PWM mode, interrupts occur at the rising edge of the PWM output.

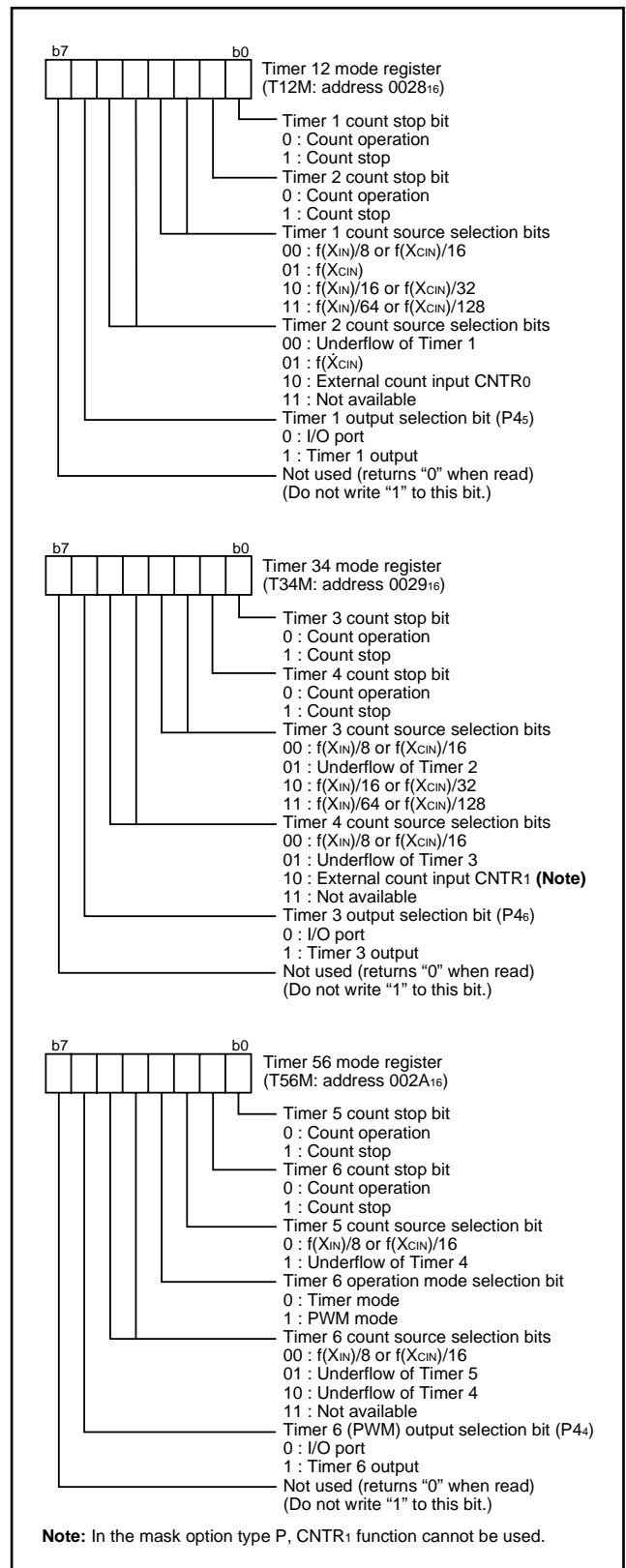

Fig. 17 Structure of timer related register

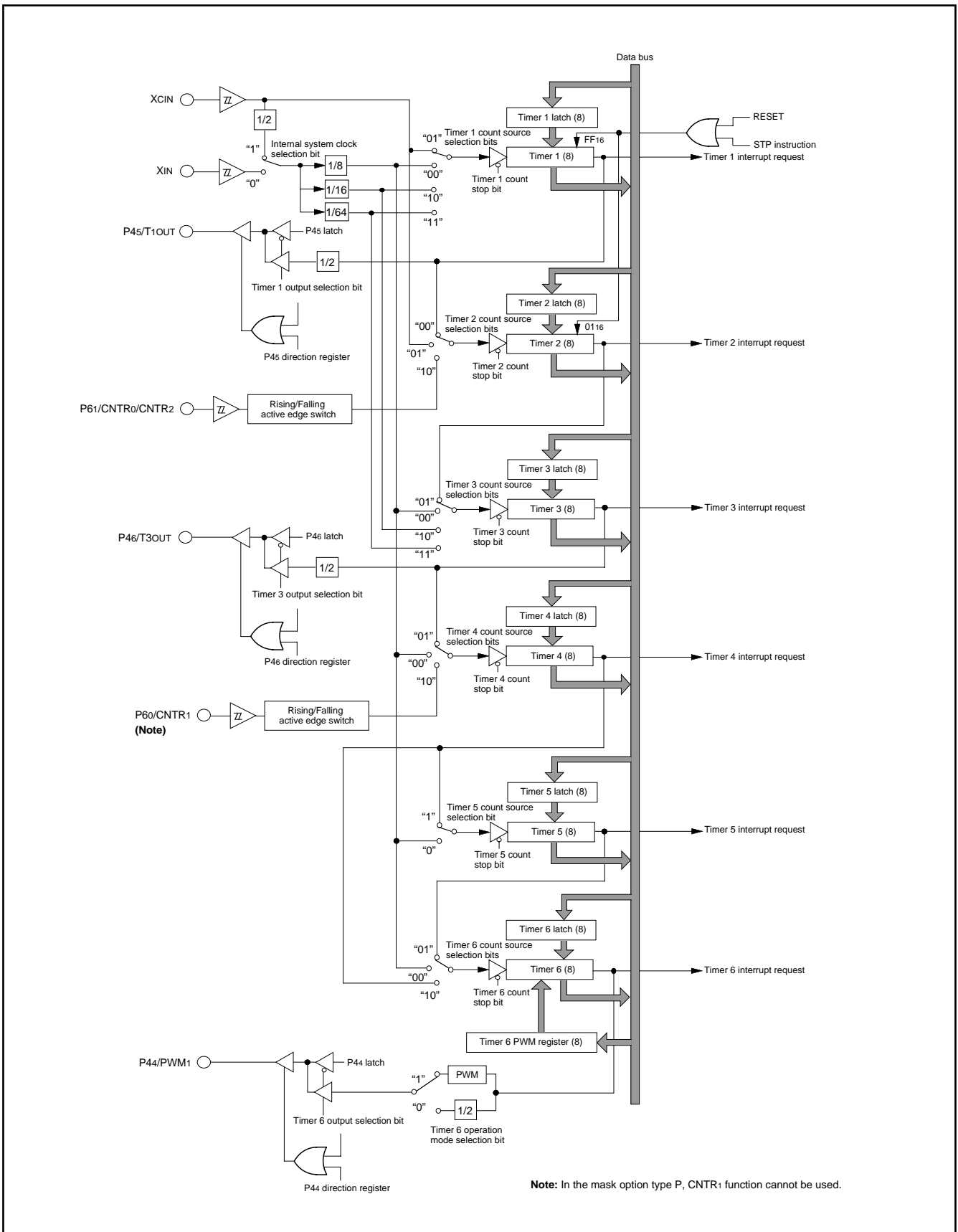

Fig. 18 Block diagram of timer



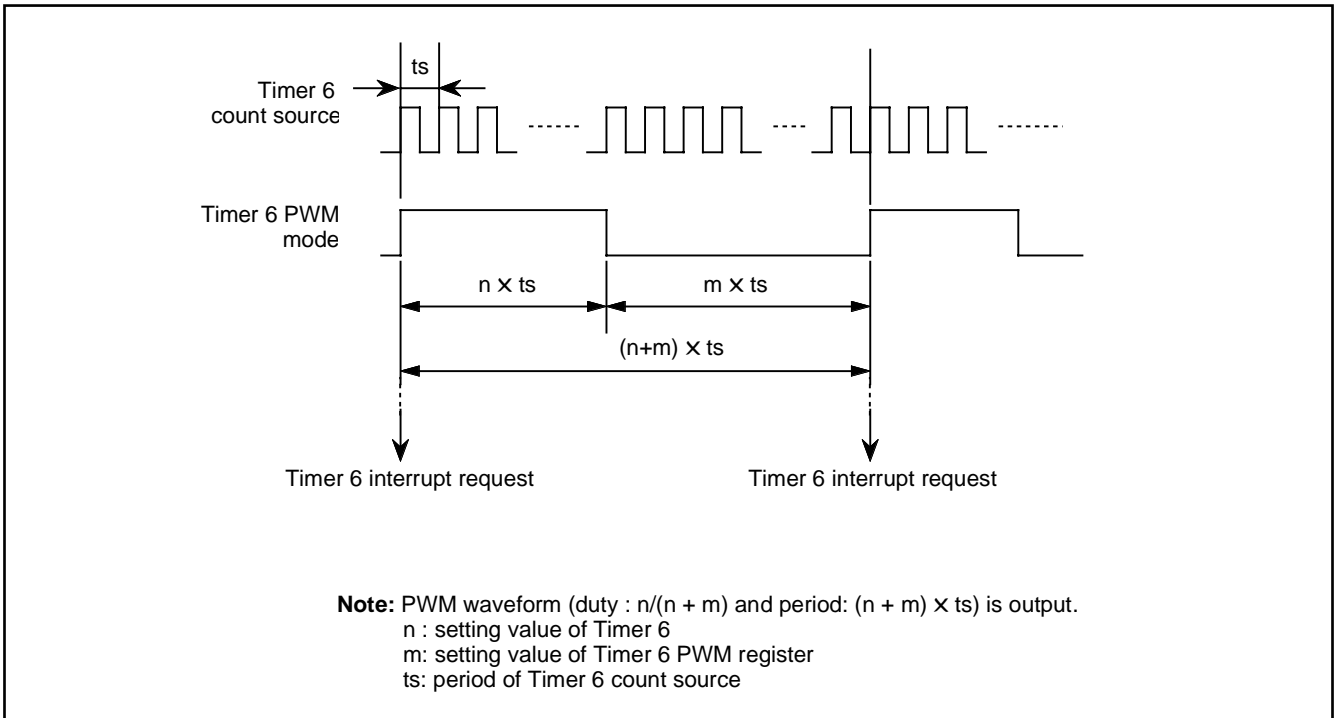

Fig. 19 Timing chart of timer 6 PWM<sub>1</sub> mode

## 16-Bit Timer

Timer X is a 16-bit timer that can be selected in one of four modes by the Timer X mode registers 1, 2 and can be controlled the timer X write and the real time port by setting the timer X mode registers.

Read and write operation on 16-bit timer must be performed for both high- and low-order bytes. When reading a 16-bit timer, read from the high-order byte first. When writing to 16-bit timer, write to the low-order byte first. The 16-bit timer cannot perform the correct operation when reading during write operation, or when writing during read operation.

### ●Timer X

Timer X is a down-counter. When the timer reaches "0000<sub>16</sub>", an underflow occurs with the next count pulse. Then the contents of the timer latch is reloaded into the timer and the timer continues down-counting. When a timer underflows, the interrupt request bit corresponding to that timer is set to "1".

#### (1) Timer mode

A count source can be selected by setting the Timer X count source selection bits (bits 1 and 2) of the Timer X mode register 1.

#### (2) Pulse output mode

Each time the timer underflows, a signal output from the CNTR<sub>2</sub> pin is inverted. Except for this, the operation in pulse output mode is the same as in timer mode. When using a timer in this mode, set the port shared with the CNTR<sub>2</sub> pin to output.

#### (3) Event counter mode

The timer counts signals input through the CNTR<sub>2</sub> pin. Except for this, the operation in event counter mode is the same as in timer mode. When using a timer in this mode, set the port shared with the CNTR<sub>2</sub> pin to input.

#### (4) Pulse width measurement mode

A count source can be selected by setting the Timer X count source selection bits (bits 1 and 2) of the Timer X mode register 1. When CNTR<sub>2</sub> active edge switch bit is "0", the timer counts while the input signal of the CNTR<sub>2</sub> pin is at "H". When it is "1", the timer counts while the input signal of the CNTR<sub>2</sub> pin is at "L". When using a timer in this mode, set the port shared with the CNTR<sub>2</sub> pin to input.

## ■ Note

### •Timer X Write Control

If the timer X write control bit is "0", when the value is written in the address of timer X, the value is loaded in the timer X and the latch at the same time.

If the timer X write control bit is "1", when the value is written in the address of timer X, the value is loaded only in the latch. The value in the latch is loaded in timer X after timer X underflows.

When the value is written in latch only, unexpected value may be set in the high-order counter if the writing in high-order latch and the underflow of timer X are performed at the same timing.

### •Real Time Port Control

While the real time port function is valid, data for the real time port are output from ports P8<sub>5</sub> and P8<sub>6</sub> each time the timer X underflows. (However, if the real time port control bit is changed from "0" to "1", data are output without the timer X.) When the data for the real time port is changed while the real time port function is valid, the changed data are output at the next underflow of timer X.

Before using this function, set the corresponding port direction registers to output mode.

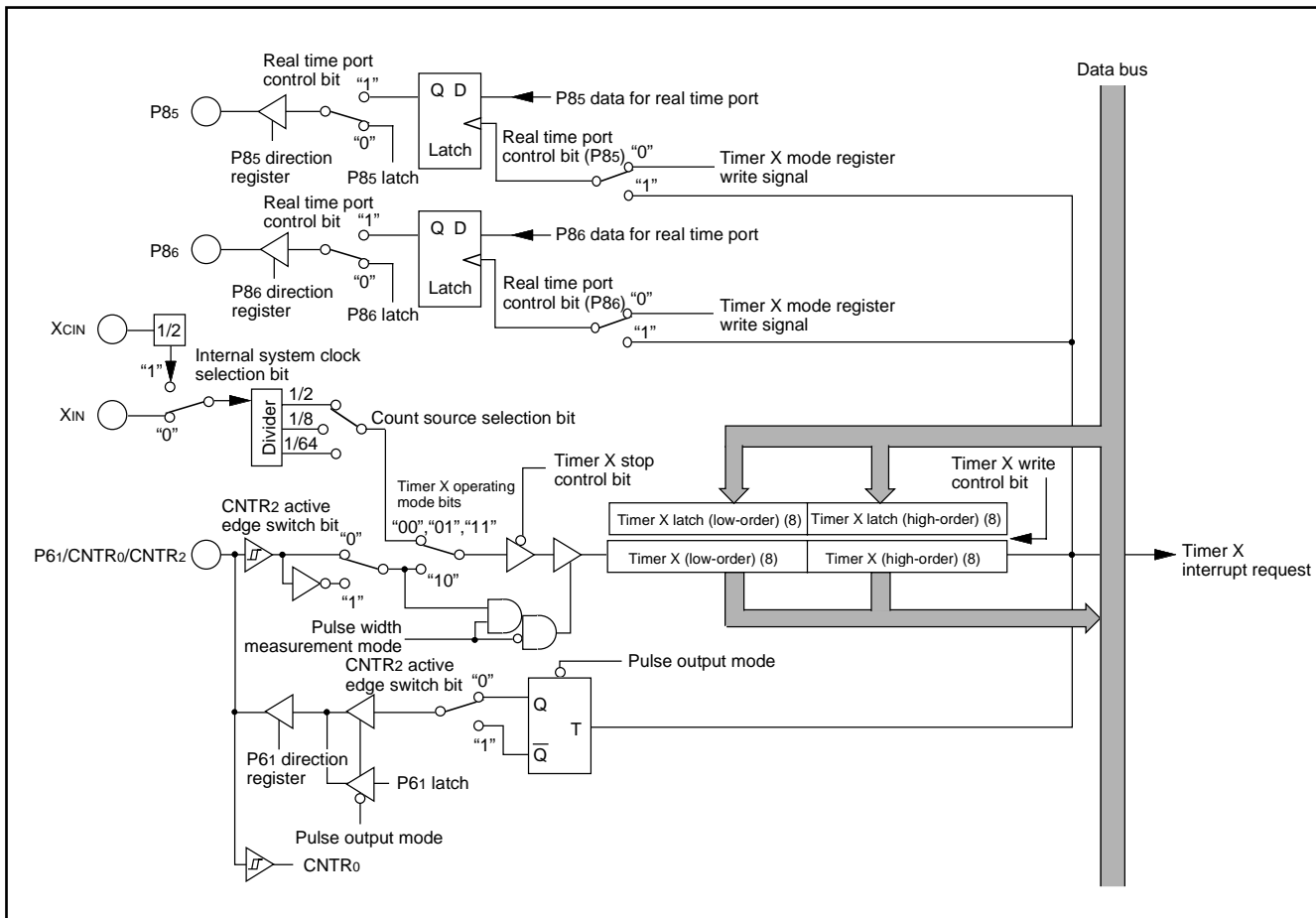

Fig. 20 Block diagram of timer X

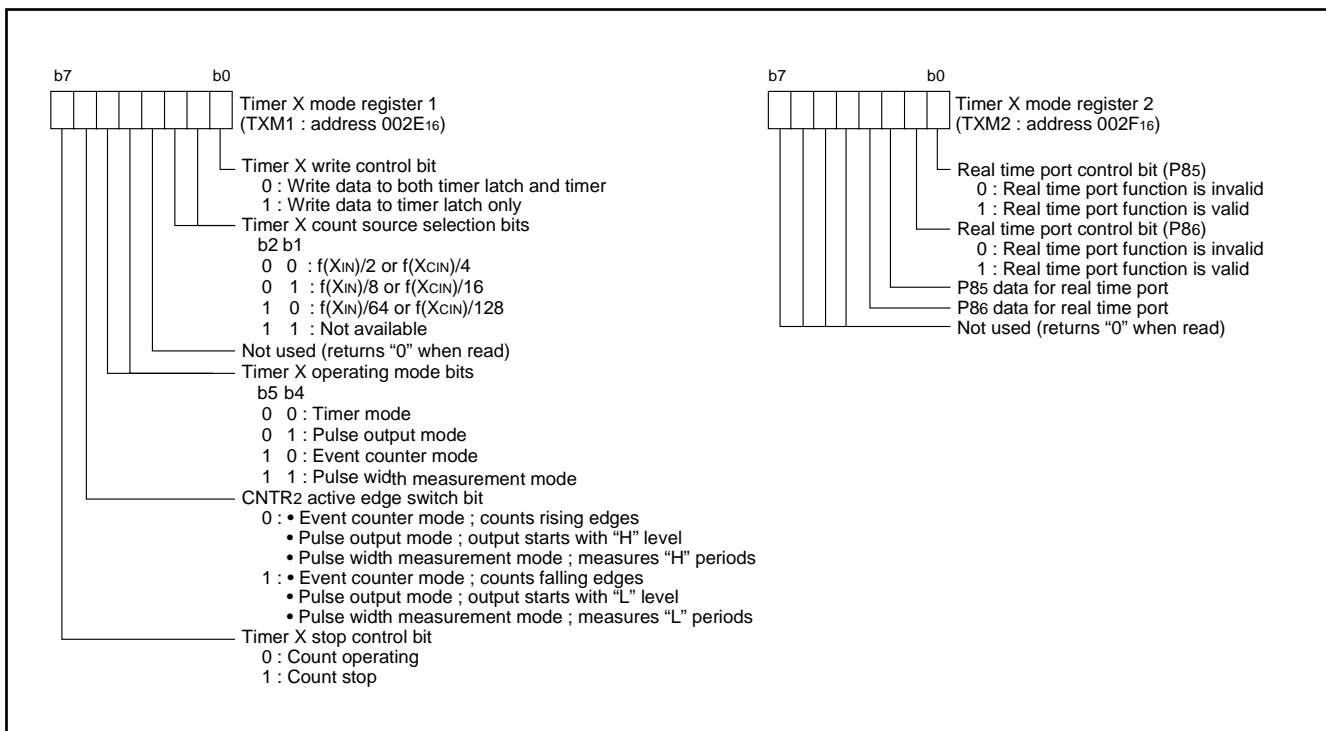

Fig. 21 Structure of timer X related registers

**SERIAL I/O**  
**Serial I/O1**

Serial I/O1 is used as the clock synchronous serial I/O and has an ordinary mode and an automatic transfer mode. In the automatic transfer mode, serial transfer is performed through the serial I/O automatic transfer RAM which has up to 256 bytes (addresses 0F00<sub>16</sub> to 0FFF<sub>16</sub>; addresses 0F60<sub>16</sub> to 0FFF<sub>16</sub> are also used as

FLD automatic display RAM).

The P62/SRDY1/AN8, P64/INT4/SBUSY1/AN10, and P65/SSTB1/AN11 pins each have a handshake I/O signal function and can select either "H" active or "L" active for active logic.

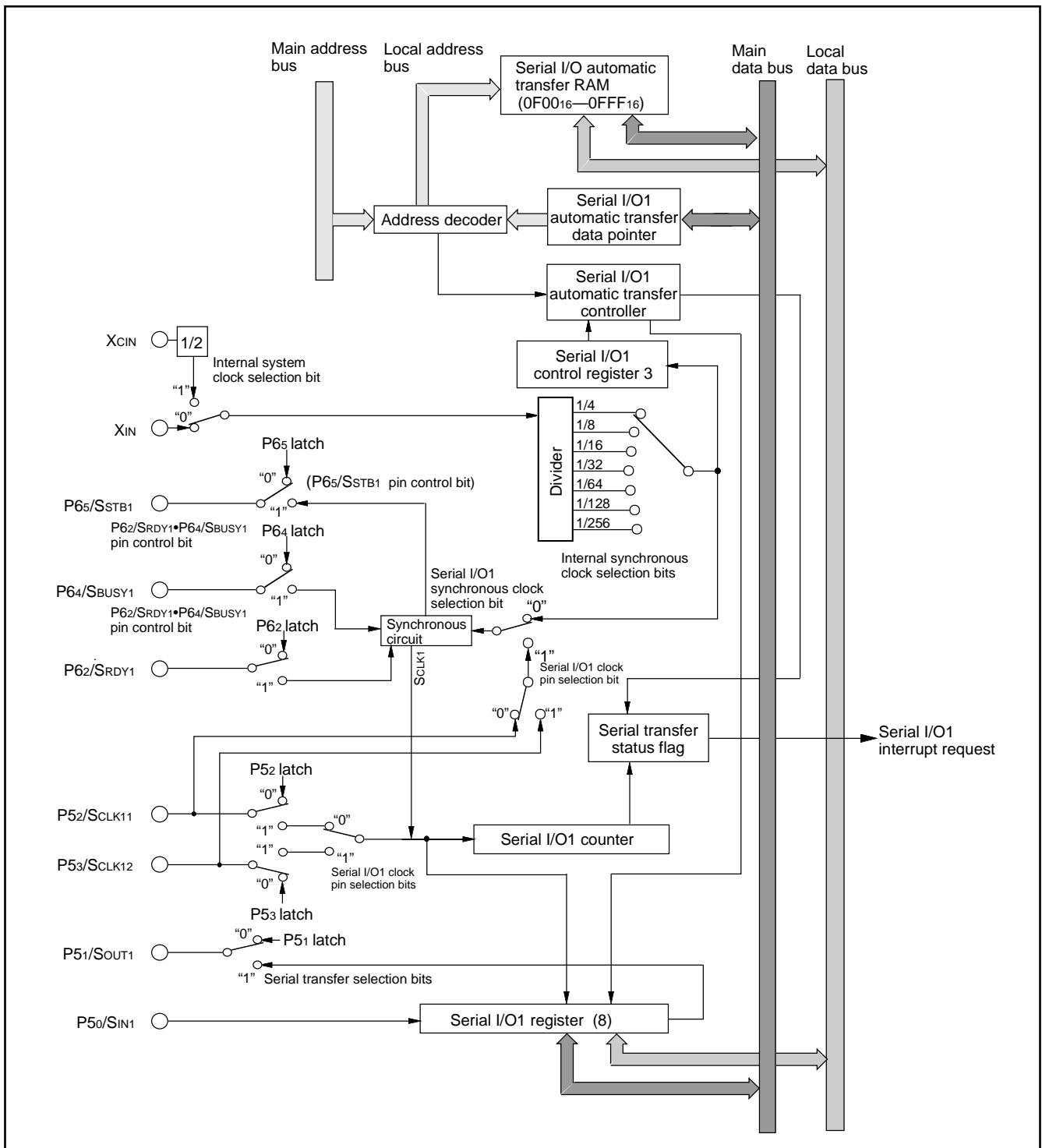

Fig. 22 Block diagram of serial I/O1

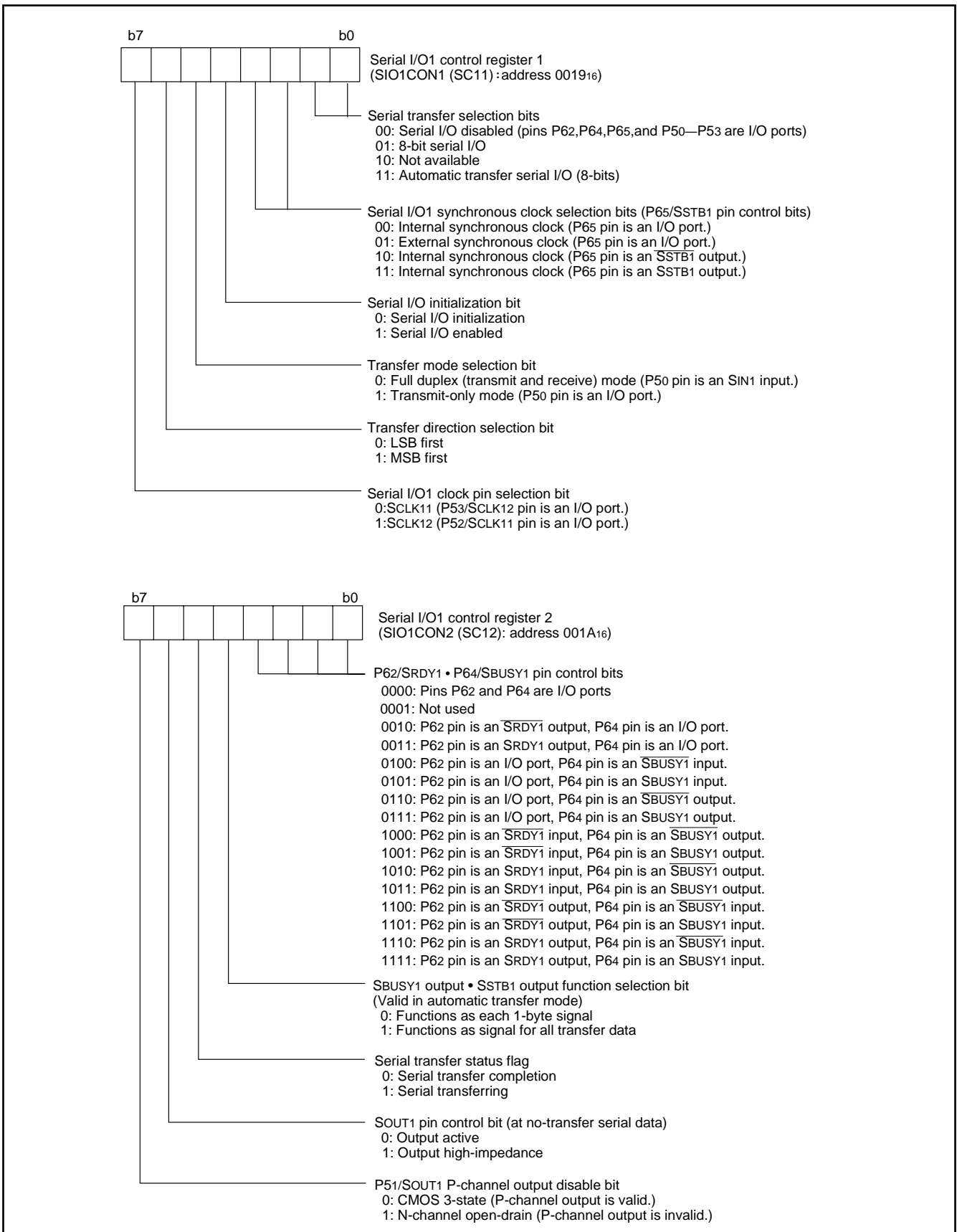

Fig. 23 Structure of serial I/O1 control registers 1, 2

●Serial I/O1 operation

Either the internal synchronous clock or external synchronous clock can be selected by the serial I/O1 synchronous clock selection bits (b2 and b3 of address 001916) of serial I/O1 control register 1 as synchronous clock for serial transfer.

The internal synchronous clock has a built-in dedicated divider where 7 different clocks are selected by the internal synchronous clock selection bits (b5, b6 and b7 of address 001C16) of serial I/O1 control register 3.

The P62/SRDY1/AN8, P64/INT4/SBUSY1/AN10, and P65/SSTB1/AN11 pins each select either I/O port or handshake I/O signal by the serial I/O1 synchronous clock selection bits (b2 and b3 of address 001916) of serial I/O1 control register 1 as well as the P62/SRDY1 • P64/SBUSY1 pin control bits (b0 to b3 of address 001A16) of serial I/O1 control register 2.

For the SOUT1 being used as an output pin, either CMOS output or N-channel open-drain output is selected by the P51/SOUT1 P-channel output disable bit (b7 of address 001A16) of serial I/O1 control register 2.

Either output active or high-impedance can be selected as a SOUT1 pin state at serial non-transfer by the SOUT1 pin control bit (b6 of address 001A16) of serial I/O1 control register 2. However, when the external synchronous clock is selected, perform the following setup to put the SOUT1 pin into a high-impedance state.

When the SCLK1 input is "H" after completion of transfer, set the SOUT1 pin control bit to "1".

When the SCLK1 input goes to "L" after the start of the next serial transfer, the SOUT1 pin control bit is automatically reset to "0" and put into an output active state.

Regardless of whether the internal synchronous clock or external synchronous clock is selected, the full duplex mode and the transmit-only mode are available for serial transfer, one of which is selected by the transfer mode selection bit (b5 of address 001916) of serial I/O1 control register 1.

Either LSB first or MSB first is selected for the I/O sequence of the serial transfer bit strings by the transfer direction selection bit (b6 of address 001916) of serial I/O1 control register 1.

When using serial I/O1, first select either 8-bit serial I/O or automatic transfer serial I/O by the serial transfer selection bits (b0 and b1 of address 001916) of serial I/O1 control register 1, after completion of the above bit setup. Next, set the serial I/O initialization bit (b4 of address 001916) of serial I/O1 control register 1 to "1" (Serial I/O enable) .

When stopping serial transfer while data is being transferred, regardless of whether the internal or external synchronous clock is selected, reset the serial I/O initialization bit (b4) to "0".

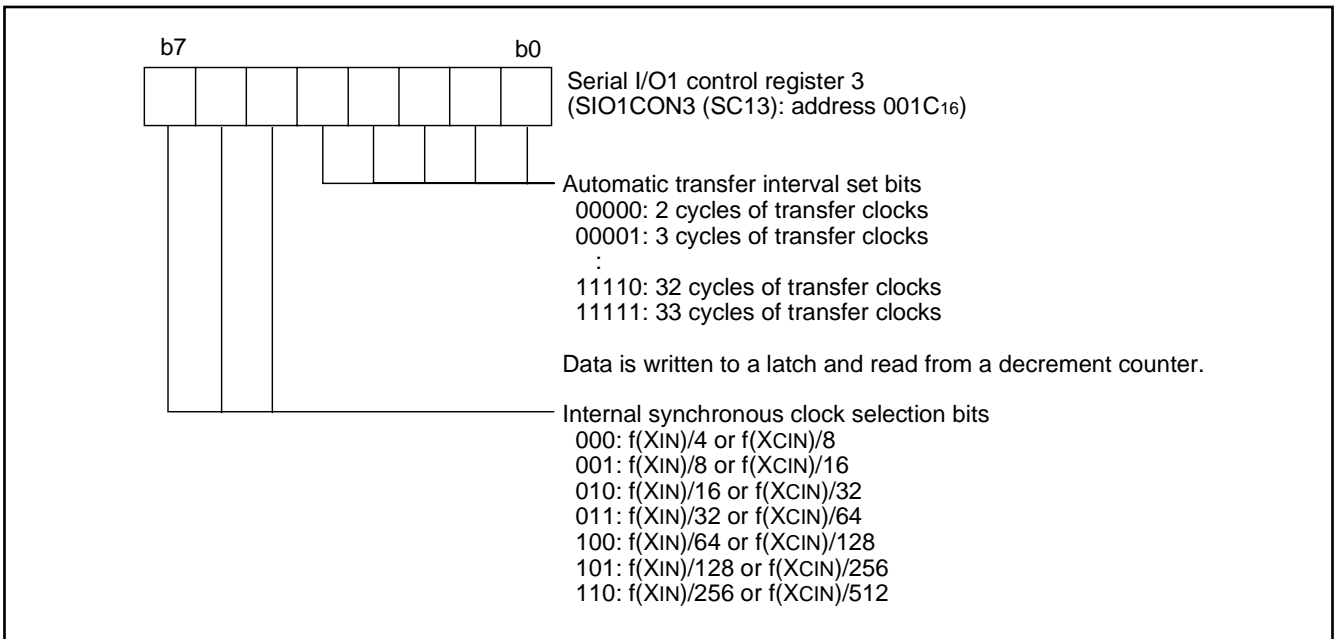

Fig. 24 Structure of serial I/O1 control register 3

**(1) 8-bit serial I/O mode**

Address 001B<sub>16</sub> is assigned to the serial I/O1 register. When the internal synchronous clock is selected, a serial transfer of the 8-bit serial I/O is started by a write signal to the serial I/O1 register (address 001B<sub>16</sub>). The serial transfer status flag (b5 of address 001A<sub>16</sub>) of serial I/O1 control register 2 indicates the shift register status of serial I/O1, and is set to "1" by writing into the serial I/O1 register, which becomes a transfer start trigger and reset to "0" after completion of 8-bit transfer. At the same time, a serial I/O1 interrupt request occurs. When the external synchronous clock is selected, the contents of the serial I/O1 register are continuously shifted while transfer clocks are input to SCLK<sub>1</sub>. Therefore, the clock needs to be controlled externally.

**(2) Automatic transfer serial I/O mode**

The serial I/O1 automatic transfer controller controls the write and read operations of the serial I/O1 register, so the function of address 001B<sub>16</sub> is used as a transfer counter (1-byte units). When performing serial transfer through the serial I/O automatic transfer RAM (addresses 0F00<sub>16</sub> to 0FFF<sub>16</sub>), it is necessary to set the serial I/O1 automatic transfer data pointer (address 0018<sub>16</sub>) beforehand. Input the low-order 8 bits of the first data store address to be serially transferred to the automatic transfer data pointer set bits. When the internal synchronous clock is selected, the transfer interval for each 1-byte data can be set by the automatic transfer interval set bits (b0 to b4 of address 001C<sub>16</sub>) of serial I/O1 control register 3 in the following cases:

1. When using no handshake signal
2. When using the SRDY<sub>1</sub> output, SBUSY<sub>1</sub> output, and SSTB<sub>1</sub> output of the handshake signal independently
3. When using a combination of SRDY<sub>1</sub> output and SSTB<sub>1</sub> output or a combination of SBUSY<sub>1</sub> output and SSTB<sub>1</sub> output of the handshake signal

It is possible to select one of 32 different values, namely 2 to 33 cycles of the transfer clock, as a setting value. When using the SBUSY<sub>1</sub> output and selecting the SBUSY<sub>1</sub> output • SSTB<sub>1</sub> output function selection bit (b4 of address 001A<sub>16</sub>) of serial I/O1 control register 2 as the signal for all transfer data, provided

that the automatic transfer interval setting is valid, a transfer interval is placed before the start of transmission/reception of the first data and after the end of transmission/reception of the last data. For SSTB<sub>1</sub> output, regardless of the contents of the SBUSY<sub>1</sub> output • SSTB<sub>1</sub> output function selection bit (b4), the transfer interval for each 1-byte data is longer than the set value by 2 cycles. Furthermore, when using a combination of SBUSY<sub>1</sub> output and SSTB<sub>1</sub> output as a signal for all transfer data, the transfer interval after the end of transmission/reception of the last data is longer than the set value by 2 cycles. When the external synchronous clock is selected, automatic transfer interval setting is disabled. After completion of the above bit setup, if the internal synchronous clock is selected, automatic serial transfer is started by writing the value of "number of transfer bytes - 1" into the transfer counter (address 001B<sub>16</sub>). When the external synchronous clock is selected, write the value of "number of transfer bytes - 1" into the transfer counter and input an internal system clock interval of 5 cycles or more. After that, input transfer clock to SCLK<sub>1</sub>. As a transfer interval for each 1-byte data transfer, input an internal system clock interval of 5 cycles or more from the clock rise time of the last bit. Regardless of whether the internal or external synchronous clock is selected, the automatic transfer data pointer and the transfer counter are decremented after each 1-byte data is received and then written into the automatic transfer RAM. The serial transfer status flag (b5 of address 001A<sub>16</sub>) is set to "1" by writing data into the transfer counter. Writing data becomes a transfer start trigger, and the serial transfer status flag is reset to "0" after the last data is written into the automatic transfer RAM. At the same time, a serial I/O1 interrupt request occurs. The values written in the automatic transfer data pointer set bits (b0 to b7 of address 0018<sub>16</sub>) and the automatic transfer interval set bits (b0 to b4 of address 001C<sub>16</sub>) are held in the latch. When data is written into the transfer counter, the values latched in the automatic transfer data pointer set bits (b0 to b7) and the automatic transfer interval set bits (b0 to b4) are transferred to the decrement counter.

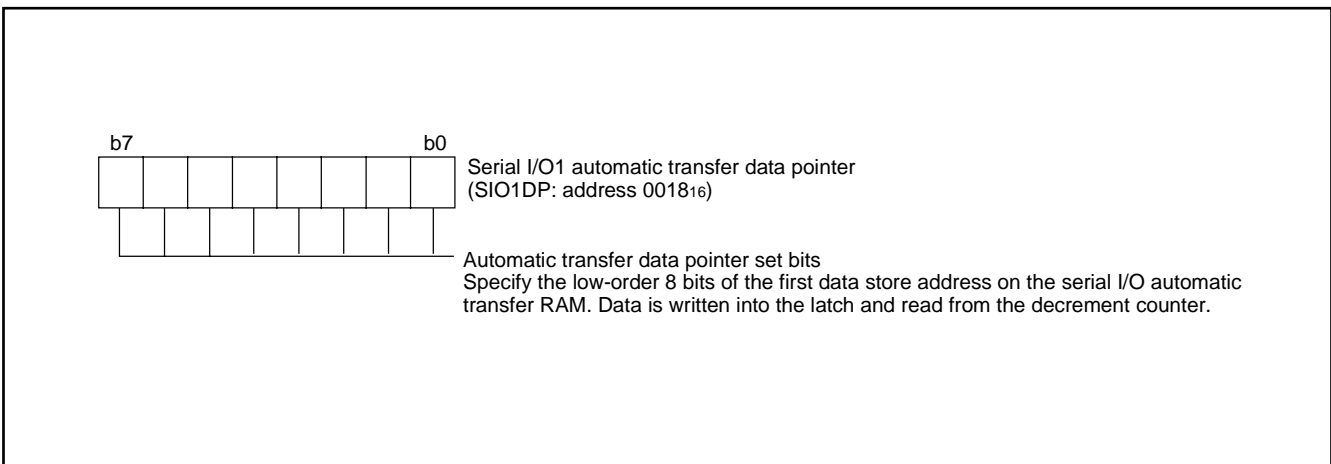

Fig. 25 Structure of serial I/O1 automatic transfer data pointer

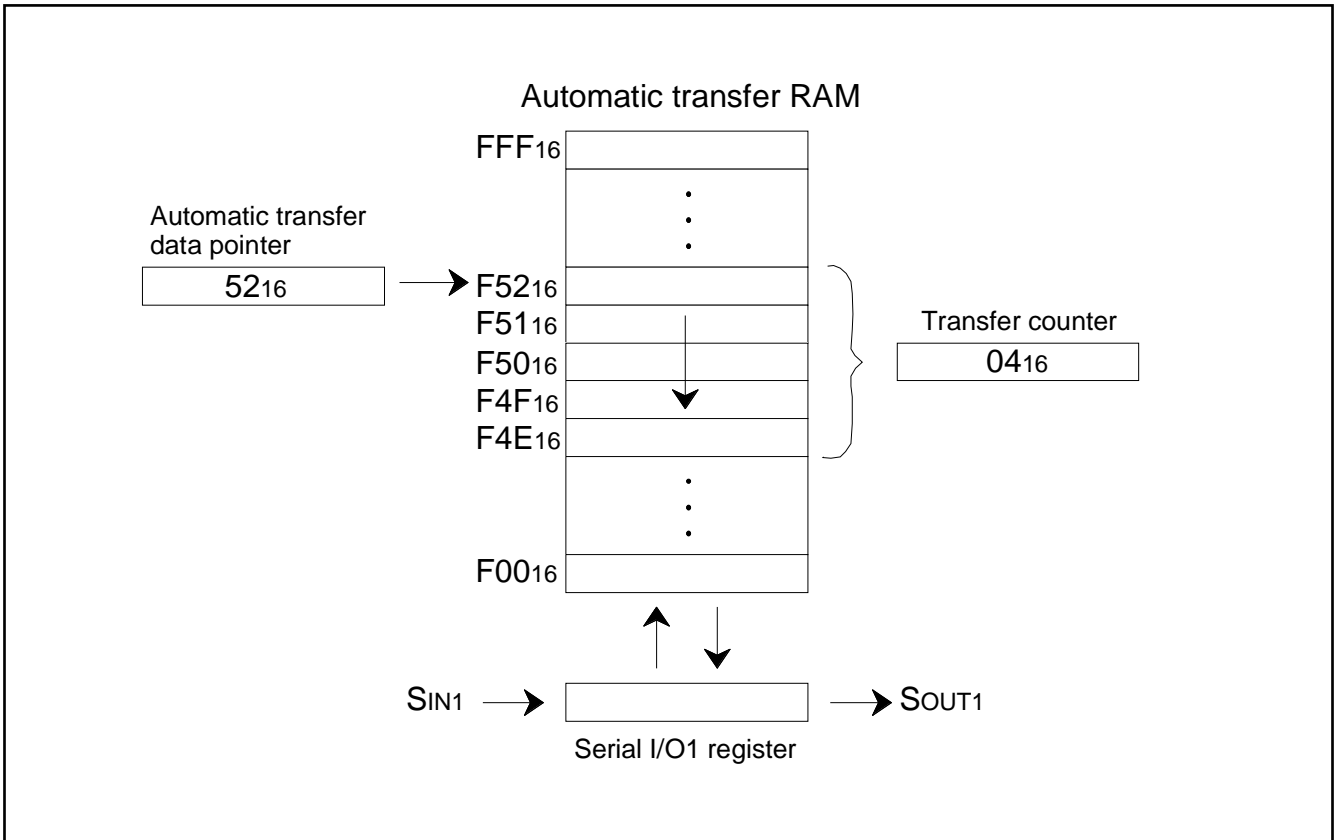

Fig. 26 Automatic transfer serial I/O operation



●Handshake signal

1. S<sub>STB1</sub> output signal

The S<sub>STB1</sub> output is a signal to inform an end of transmission/reception to the serial transfer destination. The S<sub>STB1</sub> output signal can be used only when the internal synchronous clock is selected. In the initial status, namely, in the status in which the serial I/O initialization bit (b4) is reset to "0", the S<sub>STB1</sub> output goes to "L", or the  $\overline{\text{SSTB1}}$  output goes to "H".

At the end of transmit/receive operation, when the data of the serial I/O1 register is all output from S<sub>OUT1</sub>, pulses are output in the period of 1 cycle of the transfer clock so as to cause the S<sub>STB1</sub> output to go "H" or the  $\overline{\text{SSTB1}}$  output to go "L." After that, each pulse is returned to the initial status in which S<sub>STB1</sub> output goes to "L" or the  $\overline{\text{SSTB1}}$  output goes to "H".

Furthermore, after 1 cycle, the serial transfer status flag (b5) is reset to "0".

In the automatic transfer serial I/O mode, whether the S<sub>STB1</sub> output is to be active at an end of each 1-byte data or after completion of transfer of all data can be selected by the S<sub>BUSY1</sub> output • S<sub>STB1</sub> output function selection bit (b4 of address 001A<sub>16</sub>) of serial I/O1 control register 2.

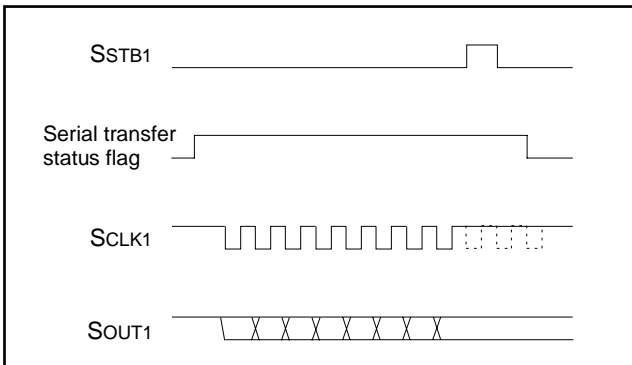

Fig. 27 S<sub>STB1</sub> output operation

2. S<sub>BUSY1</sub> input signal

The S<sub>BUSY1</sub> input is a signal which receives a request for a stop of transmission/reception from the serial transfer destination.

When the internal synchronous clock is selected, input an "H" level signal into the S<sub>BUSY1</sub> input and an "L" level signal into the  $\overline{\text{SBUSY1}}$  input in the initial status in which transfer is stopped.

When starting a transmit/receive operation, input an "L" level signal into the S<sub>BUSY1</sub> input and an "H" level signal into the  $\overline{\text{SBUSY1}}$  input in the period of 1.5 cycles or more of the transfer clock. Then, transfer clocks are output from the S<sub>CLK1</sub> output.

When an "H" level signal is input into the S<sub>BUSY1</sub> input and an "L" level signal into the  $\overline{\text{SBUSY1}}$  input after a transmit/receive operation is started, this transmit/receive operation are not stopped immediately and the transfer clocks from the S<sub>CLK1</sub> output is not stopped until the specified number of bits are transmitted and received.

The handshake unit of the 8-bit serial I/O is 8 bits and that of the automatic transfer serial I/O is 8 bits.

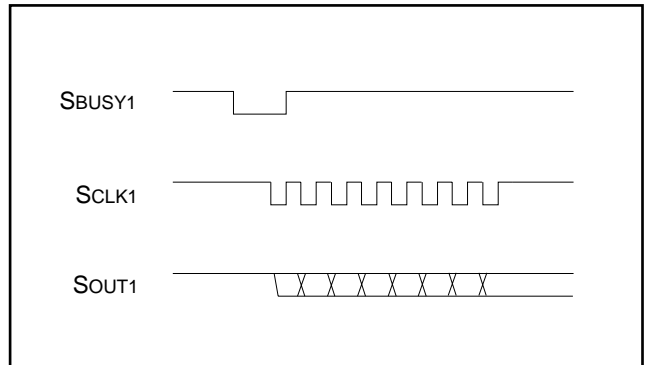

Fig. 28 S<sub>BUSY1</sub> input operation (internal synchronous clock)

When the external synchronous clock is selected, input an "H" level signal into the S<sub>BUSY1</sub> input and an "L" level signal into the  $\overline{\text{SBUSY1}}$  input in the initial status in which transfer is stopped. At this time, the transfer clocks to be input in S<sub>CLK1</sub> become invalid.

During serial transfer, the transfer clocks to be input in S<sub>CLK1</sub> become valid, enabling a transmit/receive operation, while an "L" level signal is input into the S<sub>BUSY1</sub> input and an "H" level signal is input into the  $\overline{\text{SBUSY1}}$  input.

When changing the input values in the S<sub>BUSY1</sub> input and the  $\overline{\text{SBUSY1}}$  input at these operations, change them when the S<sub>CLK1</sub> input is in a high state.

When the high impedance of the S<sub>OUT1</sub> output is selected by the S<sub>OUT1</sub> pin control bit (b6), the S<sub>OUT1</sub> output becomes active, enabling serial transfer by inputting a transfer clock to S<sub>CLK1</sub>, while an "L" level signal is input into the S<sub>BUSY1</sub> input and an "H" level signal is input into the  $\overline{\text{SBUSY1}}$  input.

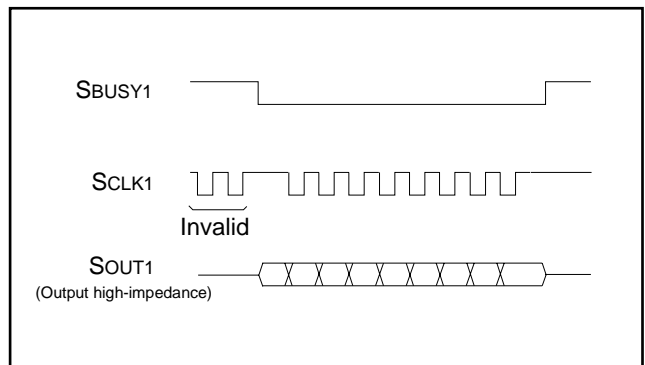

Fig. 29 S<sub>BUSY1</sub> input operation (external synchronous clock)

3. S<sub>BUSY1</sub> output signal

The S<sub>BUSY1</sub> output is a signal which requests a stop of transmission/reception to the serial transfer destination. In the automatic transfer serial I/O mode, regardless of the internal or external synchronous clock, whether the S<sub>BUSY1</sub> output is to be active at transfer of each 1-byte data or during transfer of all data can be selected by the S<sub>BUSY1</sub> output • S<sub>STB1</sub> output function selection bit (b4).

In the initial status, the status in which the serial I/O initialization bit (b4) is reset to "0", the S<sub>BUSY1</sub> output goes to "H" and the  $\overline{\text{SBUSY1}}$  output goes to "L".

When the internal synchronous clock is selected, in the 8-bit serial I/O mode and the automatic transfer serial I/O mode (SBUSY1 output function outputs in 1-byte units), the SBUSY1 output goes to "L" and the SBUSY1 output goes to "H" before 0.5 cycle (transfer clock) of the timing at which the transfer clock from the SCLK1 output goes to "L" at a start of transmit/receive operation.

In the automatic transfer serial I/O mode (the SBUSY1 output function outputs all transfer data), the SBUSY1 output goes to "L" and the SBUSY1 output goes to "H" when the first transmit data is written into the serial I/O1 register (address 001B16).

When the external synchronous clock is selected, the SBUSY1 output goes to "L" and the SBUSY1 output goes to "H" when transmit

data is written into the serial I/O1 register to start a transmit operation, regardless of the serial I/O transfer mode.

At termination of transmit/receive operation, the SBUSY1 output returns to "H" and the SBUSY1 output returns to "L", the initial status, when the serial transfer status flag is set to "0", regardless of whether the internal or external synchronous clock is selected.

Furthermore, in the automatic transfer serial I/O mode (SBUSY1 output function outputs in 1-byte units), the SBUSY1 output goes to "H" and the SBUSY1 output goes to "L" each time 1-byte of receive data is written into the automatic transfer RAM.

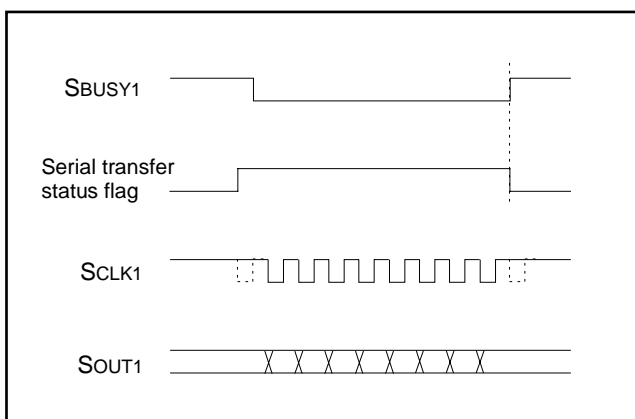

Fig. 30 SBUSY1 output operation (internal synchronous clock, 8-bits serial I/O)

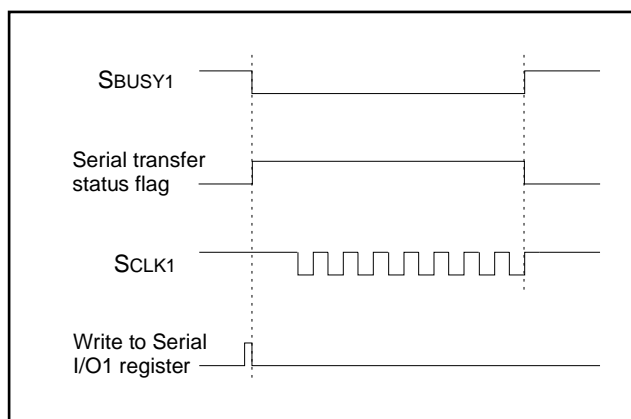

Fig. 31 SBUSY1 output operation (external synchronous clock, 8-bits serial I/O)

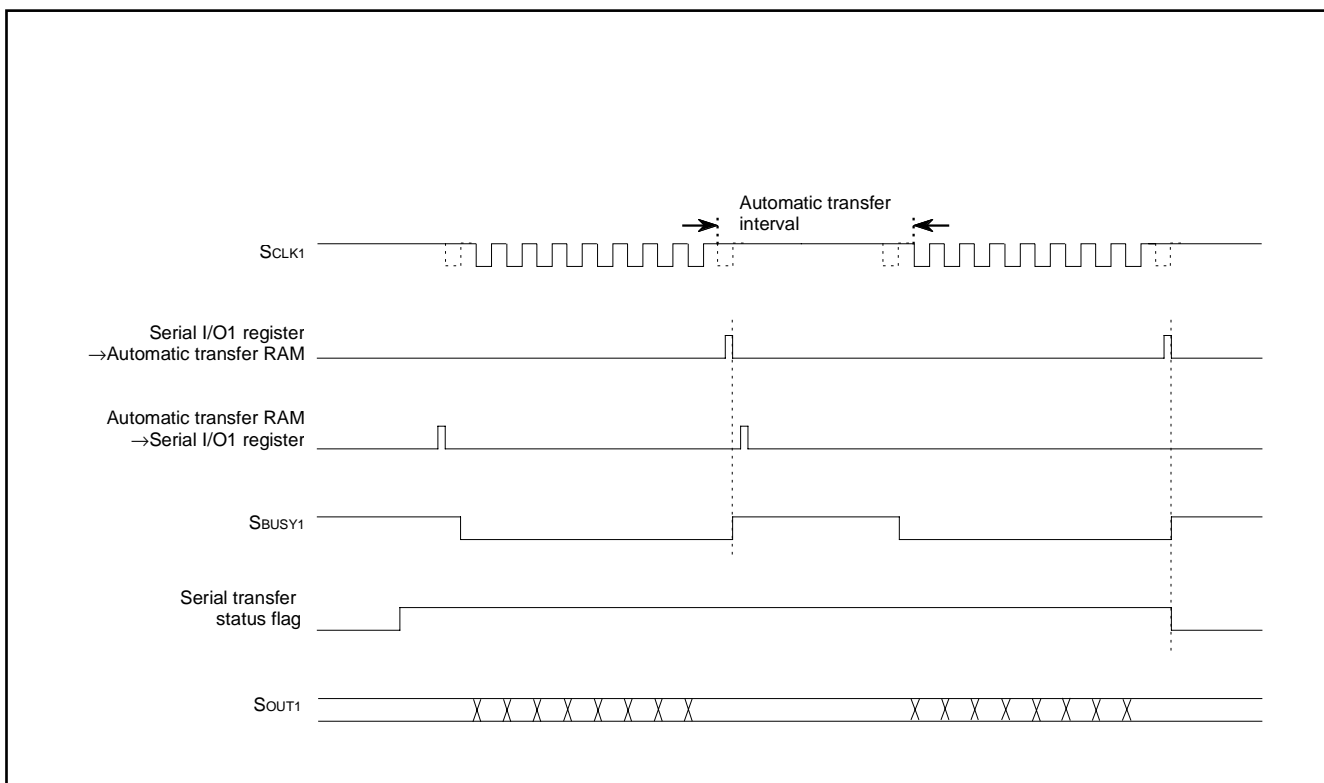

Fig. 32 SBUSY1 output operation in automatic transfer serial I/O mode (internal synchronous clock, SBUSY1 output function outputs each 1-byte)

**4. SRDY1 output signal**

The SRDY1 output is a transmit/receive enable signal which informs the serial transfer destination that transmit/receive is ready. In the initial status, when the serial I/O initialization bit (b4) is reset to "0", the SRDY1 output goes to "L" and the  $\overline{\text{SRDY1}}$  output goes to "H". After transmitted data is stored in the serial I/O1 register (address 001B16) and a transmit/receive operation becomes ready, the SRDY1 output goes to "H" and the  $\overline{\text{SRDY1}}$  output goes to "L". When a transmit/receive operation is started and the transfer clock goes to "L", the SRDY1 output goes to "L" and the  $\overline{\text{SRDY1}}$  output goes to "H".

**5. SRDY1 input signal**

The SRDY1 input signal becomes valid only when the SRDY1 input and the SBUSY1 output are used. The SRDY1 input is a signal for receiving a transmit/receive ready completion signal from the serial transfer destination.

When the internal synchronous clock is selected, input a low level signal into the SRDY1 input and a high level signal into the  $\overline{\text{SRDY1}}$  input in the initial status in which the transfer is stopped.

When an "H" level signal is input into the SRDY1 input and an "L" level signal is input into the  $\overline{\text{SRDY1}}$  input for a period of 1.5 cycles or more of transfer clock, transfer clocks are output from the SCLK1 output and a transmit/receive operation is started.

After the transmit/receive operation is started and an "L" level signal is input into the SRDY1 input and an "H" level signal into the  $\overline{\text{SRDY1}}$  input, this operation cannot be immediately stopped.

After the specified number of bits are transmitted and received, the transfer clocks from the SCLK1 output is stopped. The handshake unit of the 8-bit serial I/O and that of the automatic transfer serial I/O are of 8 bits.

When the external synchronous clock is selected, the SRDY1 input becomes one of the triggers to output the SBUSY1 signal.

To start a transmit/receive operation (SBUSY1 output: "L", SBUSY1 output: "H"), input an "H" level signal into the SRDY1 input and an "L" level signal into the  $\overline{\text{SRDY1}}$  input, and also write transmit data into the serial I/O1 register.

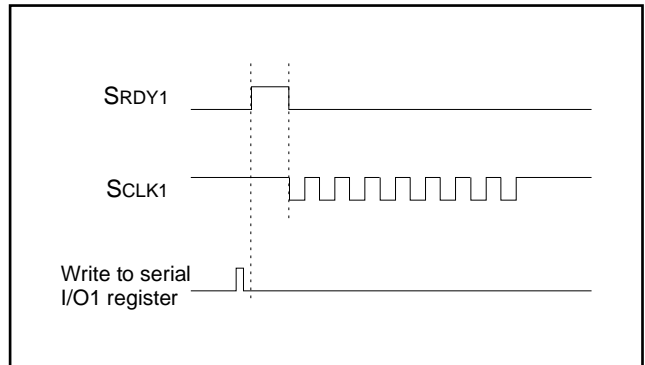

**Fig. 33 SRDY1 output operation**

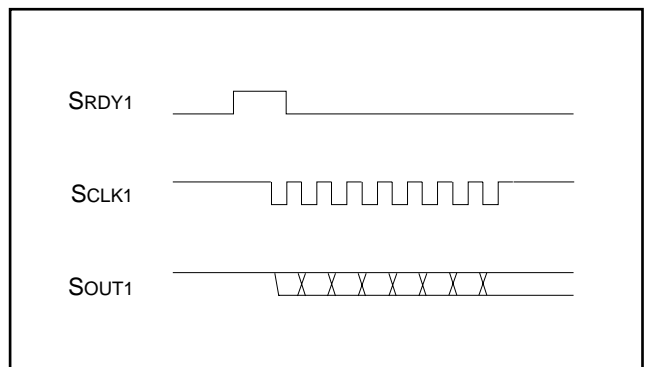

**Fig. 34 SRDY1 input operation (internal synchronous clock)**

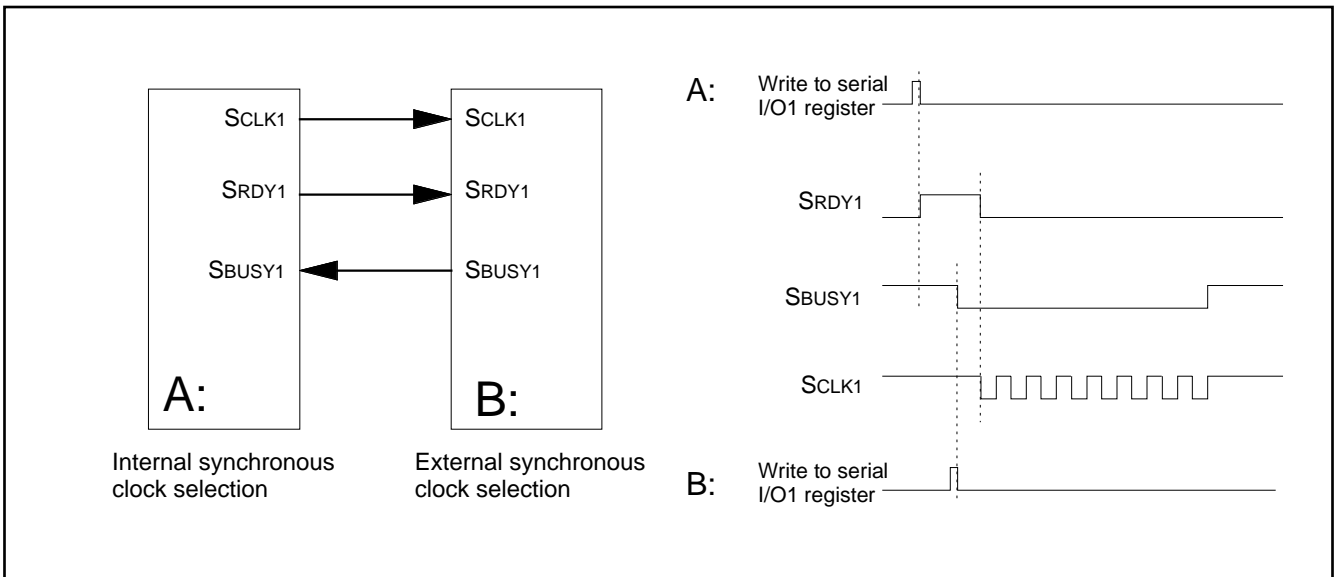

Fig. 35 Handshake operation at serial I/O1 mutual connecting (1)

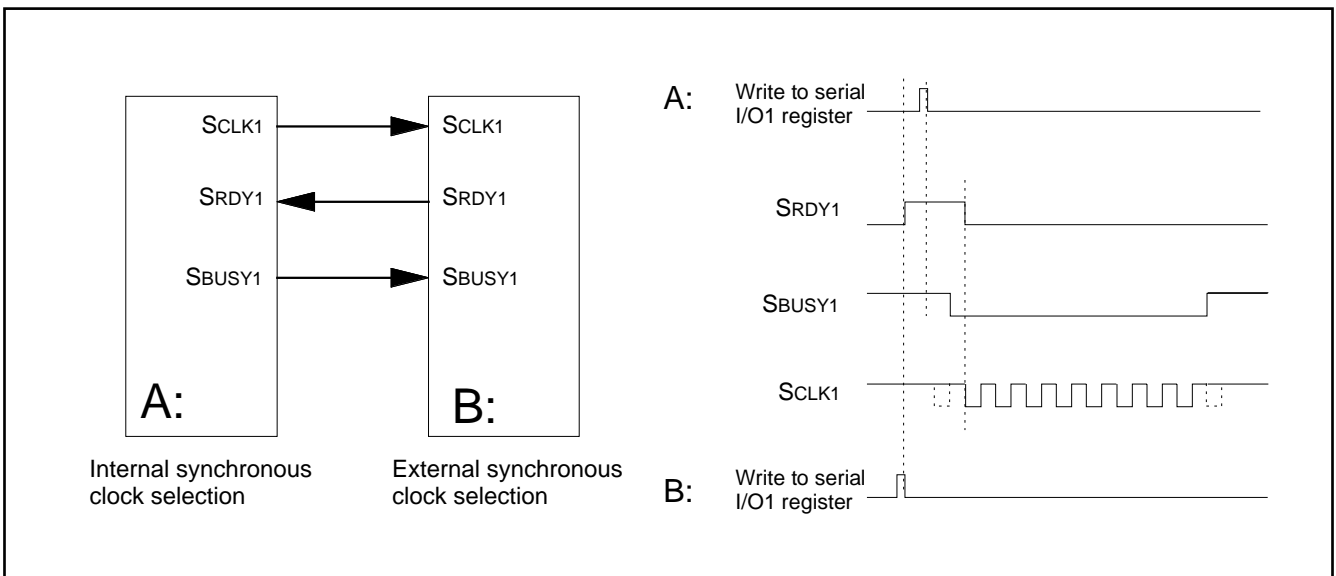

Fig. 36 Handshake operation at serial I/O1 mutual connecting (2)

**Serial I/O2**

Serial I/O2 can be used as either clock synchronous or asynchronous (UART) serial I/O. A dedicated timer (baud rate generator) is also provided for baud rate generation during serial I/O2 operation.

**(1) Clock synchronous serial I/O mode**

The clock synchronous serial I/O mode can be selected by setting the serial I/O2 mode selection bit (b6) of the serial I/O2 control reg-

ister (address 001D16) to "1". For clock synchronous serial I/O, the transmitter and the receiver must use the same clock for serial I/O2 operation. If an internal clock is used, transmit/receive is started by a write signal to the serial I/O2 transmit/receive buffer register (TB/RB) (address 001F16).

When P57 (SCLK22) is selected as a clock I/O pin,  $\overline{\text{SRDY2}}$  output function is invalid, and P56 (SCLK21) is used as an I/O port.

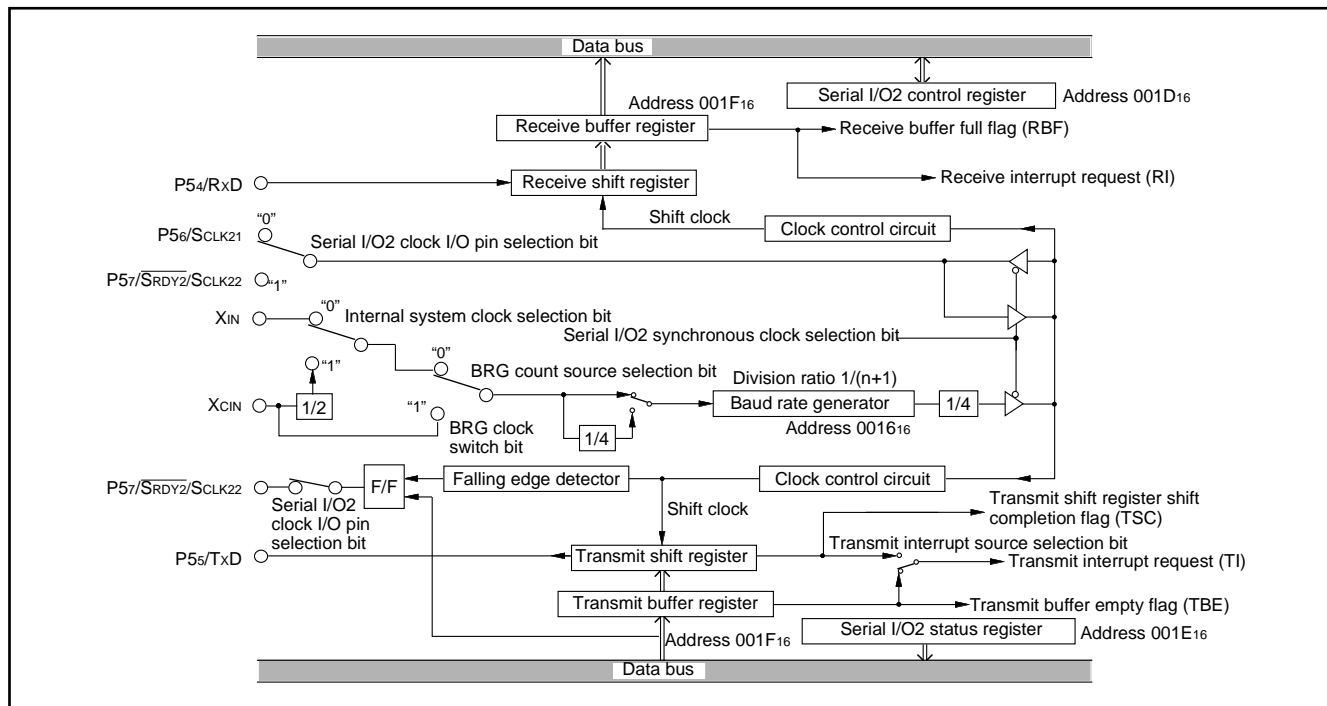

Fig. 37 Block diagram of clock synchronous serial I/O2

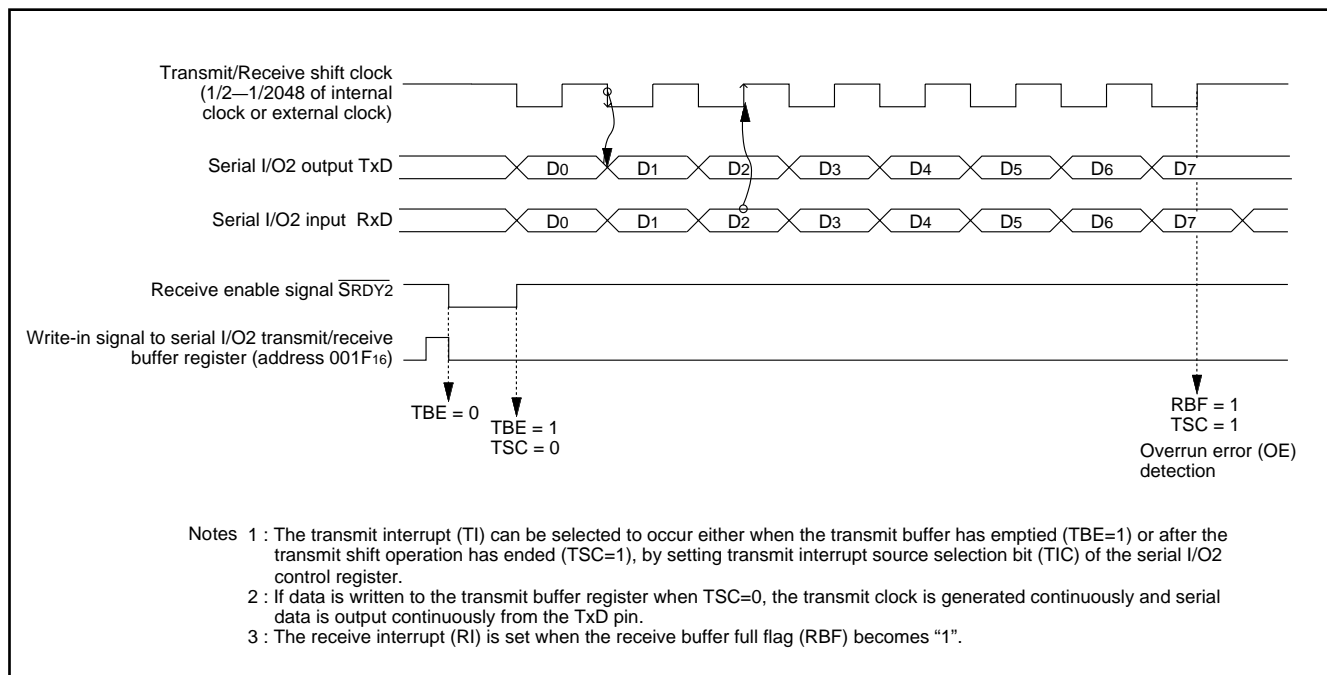

Fig. 38 Operation of clock synchronous serial I/O2 function

**(2) Asynchronous serial I/O (UART) mode**

The asynchronous serial I/O (UART) mode can be selected by clearing the serial I/O2 mode selection bit (b6) of the serial I/O2 control register (address 001D<sub>16</sub>) to "0". Eight serial data transfer formats can be selected and the transfer formats used by the transmitter and receiver must be identical.

The transmit and receive shift registers each have a buffer (the two buffers have the same address in memory). Since the shift register cannot be written to or read from directly, transmit data is written to the transmit buffer, and receive data is read from the receive buffer. The transmit buffer can also hold the next data to be transmitted, and the receive buffer can receive 2-byte data continuously.

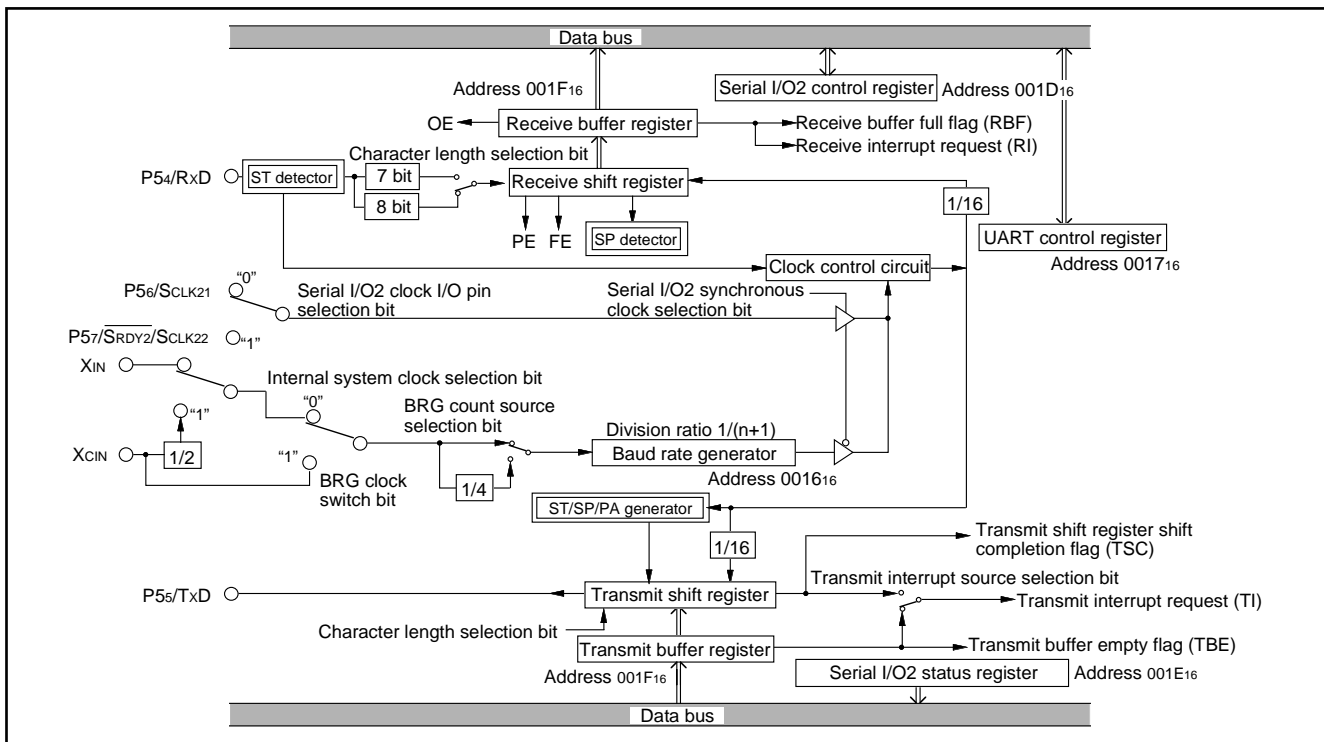

Fig. 39 Block diagram of UART serial I/O2

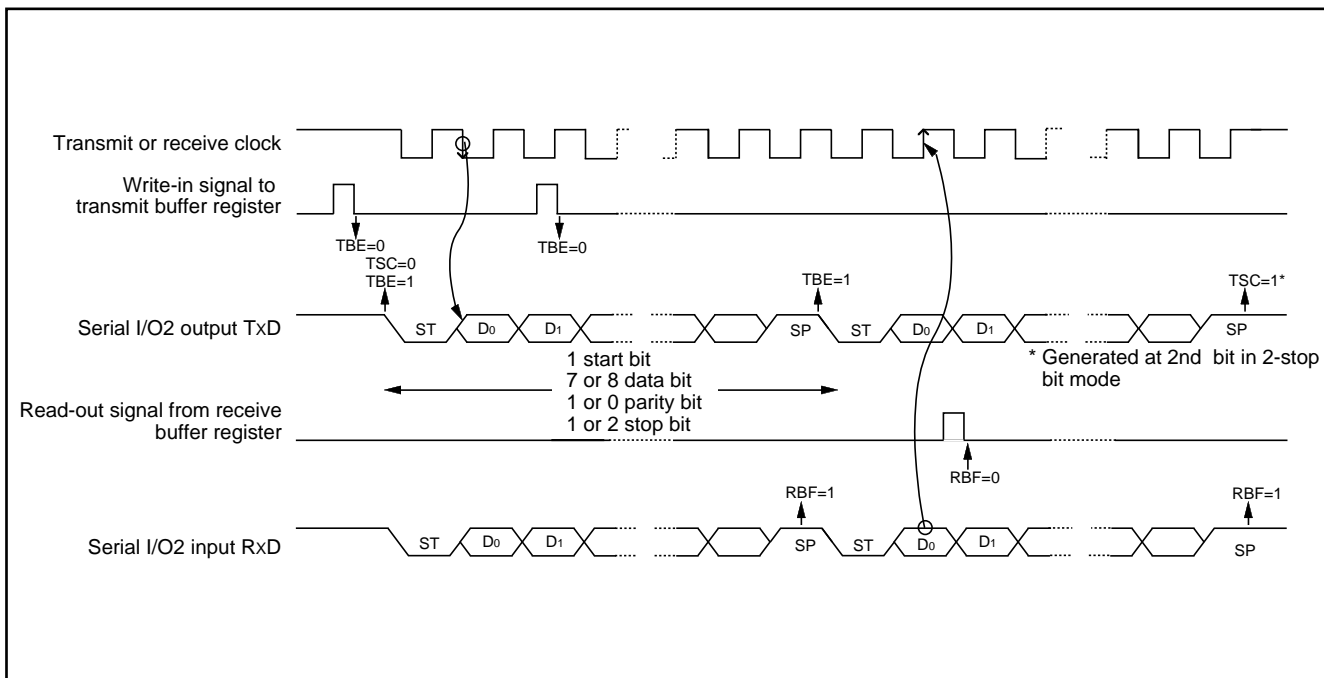

Fig. 40 Operation of UART serial I/O2 function

**[Serial I/O2 Control Register] SIO2CON (001D16)**

The serial I/O2 control register contains eight control bits for serial I/O2 functions.

**[UART Control Register] UARTCON (001716)**

This is a 7 bit register containing four control bits, which are valid when UART is selected, two control bits, which are valid when using serial I/O2, and one control bit, which is always valid.

Data format of serial data receive/transfer and the output structure of the P55/TxD pin, etc. are set by this register.

**[Serial I/O2 Status Register] SIO2STS (001E16)**

The read-only serial I/O2 status register consists of seven flags (b0 to b6) which indicate the operating status of the serial I/O2 function and various errors. Three of the flags (b4 to b6) are only valid in the UART mode. The receive buffer full flag (b1) is cleared to "0" when the receive buffer is read.

The error detection is performed at the same time data is transferred from the receive shift register to the receive buffer register, and the receive buffer full flag is set. A writing to the serial I/O2 status regis-

ter clears error flags OE, PE, FE, and SE (b3 to b6, respectively). Writing "0" to the serial I/O2 enable bit (SIOE : b7 of the serial I/O2 control register) also clears all the status flags, including the error flags.

All bits of the serial I/O2 status register are initialized to "0" at reset, but if the transmit enable bit (b4) of the serial I/O2 control register has been set to "1", the transmit shift register shift completion flag (b2) and the transmit buffer empty flag (b0) become "1".

**[Serial I/O2 Transmit Buffer Register/Receive Buffer Register] TB/RB (001F16)**

The transmit buffer and the receive buffer are located in the same address. The transmit buffer is write-only and the receive buffer is read-only. If a character bit length is 7 bits, the MSB of data stored in the receive buffer is "0".

**[Baud Rate Generator] BRG (001616)**

The baud rate generator determines the baud rate for serial transfer. With the 8-bit counter having a reload register, the baud rate generator divides the frequency of the count source by 1/(n+1), where n is the value written to the baud rate generator.

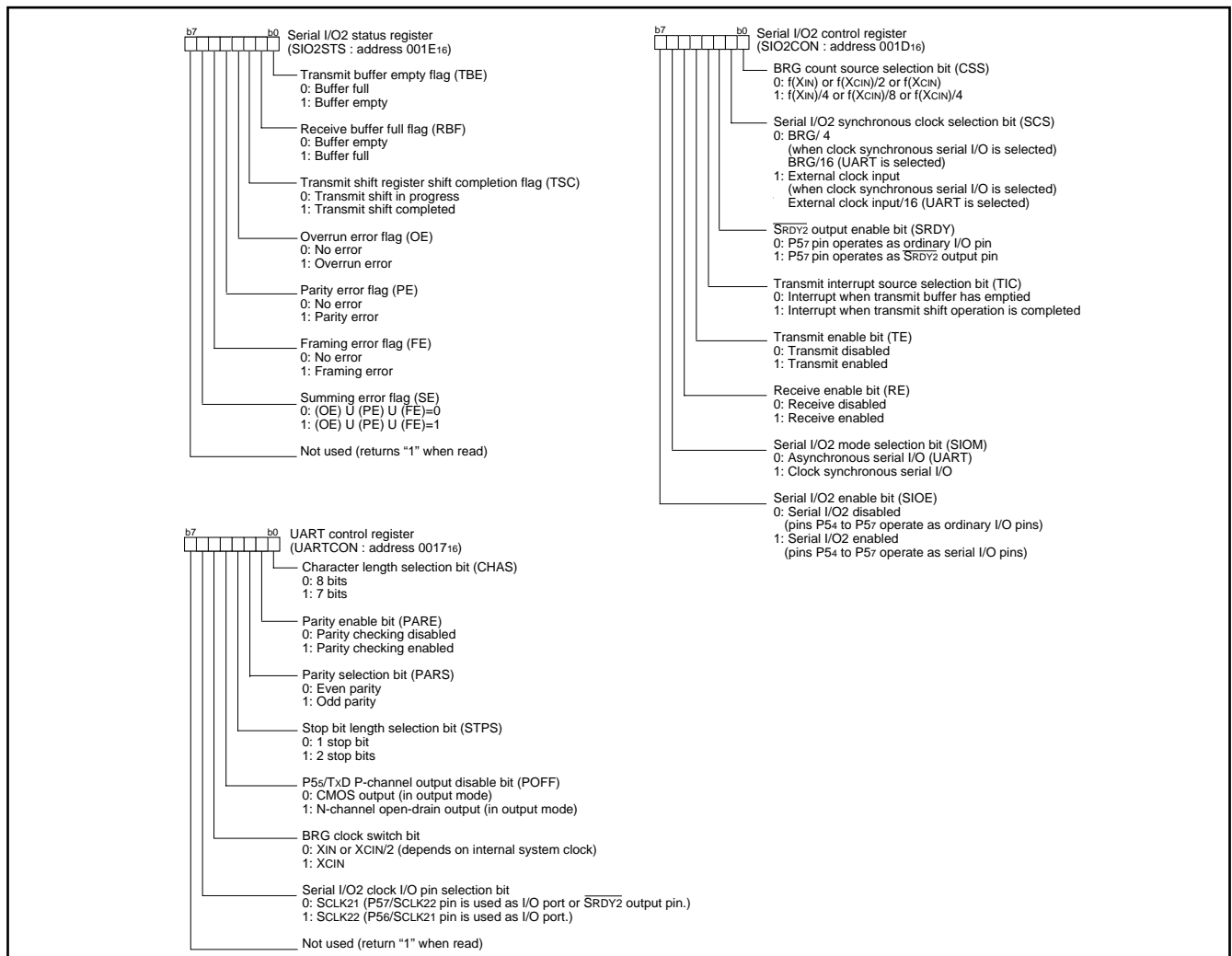

Fig. 41 Structure of serial I/O2 related register

**FLD CONTROLLER**

The 38B4 group has fluorescent display (FLD) drive and control circuits.

The FLD controller consists of the following components:

- 40 pins for FLD control pins
- FLDC mode register
- FLD data pointer
- FLD data pointer reload register
- Tdisp time set register

- Toff1 time set register
- Toff2 time set register
- Port P0FLD/port switch register
- Port P2FLD/port switch register
- Port P8FLD/port switch register
- Port P8 FLD output control register
- FLD automatic display RAM (max. 160 bytes)

A gradation display mode can be used for bright/dark display as a display function.

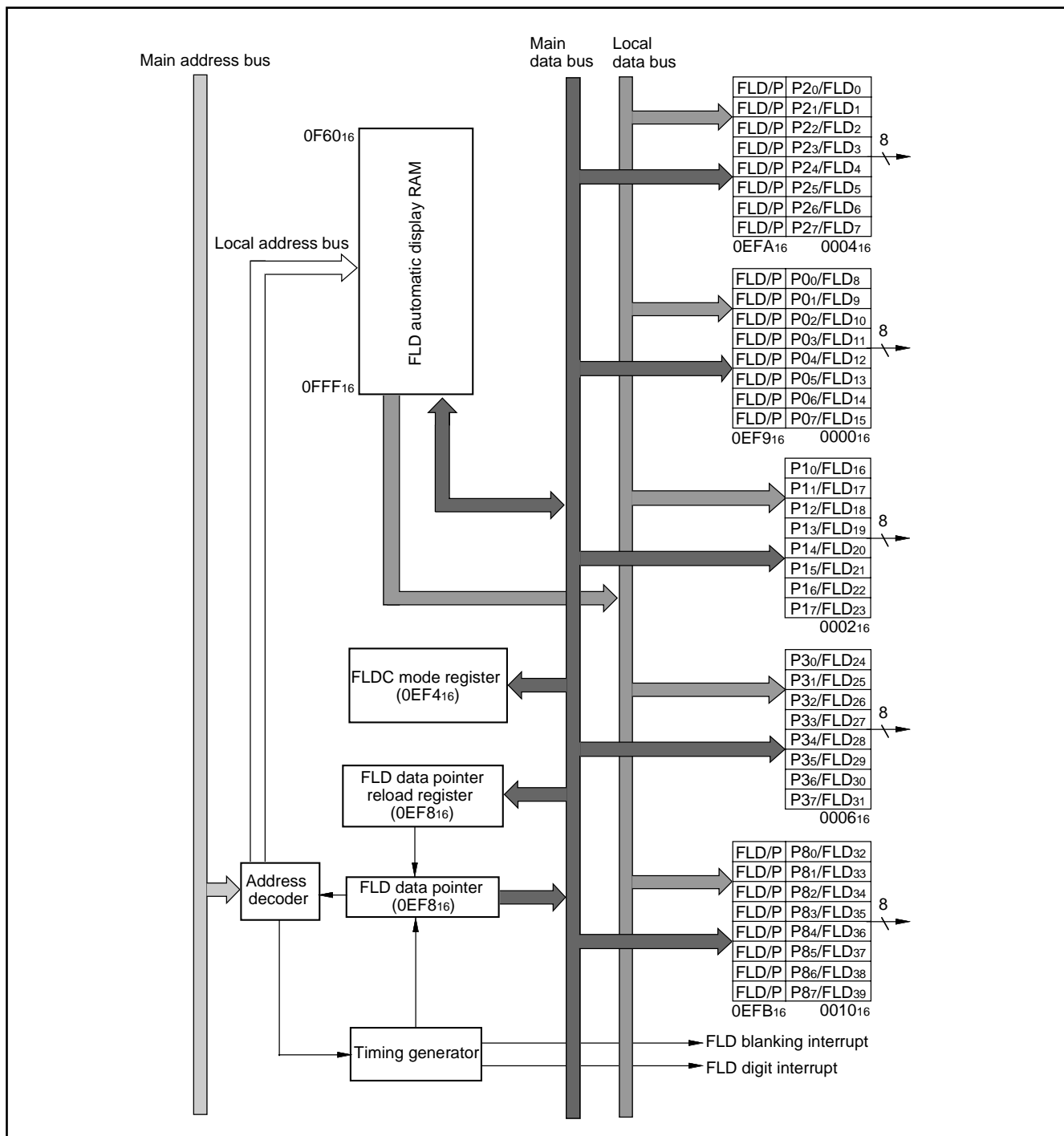

Fig. 42 Block diagram for FLD control circuit



**[FLDC Mode Register] FLDM**

The FLDC mode register is a 8-bit register respectively which is used to control the FLD automatic display and to set the blanking time Tscan for key-scan.

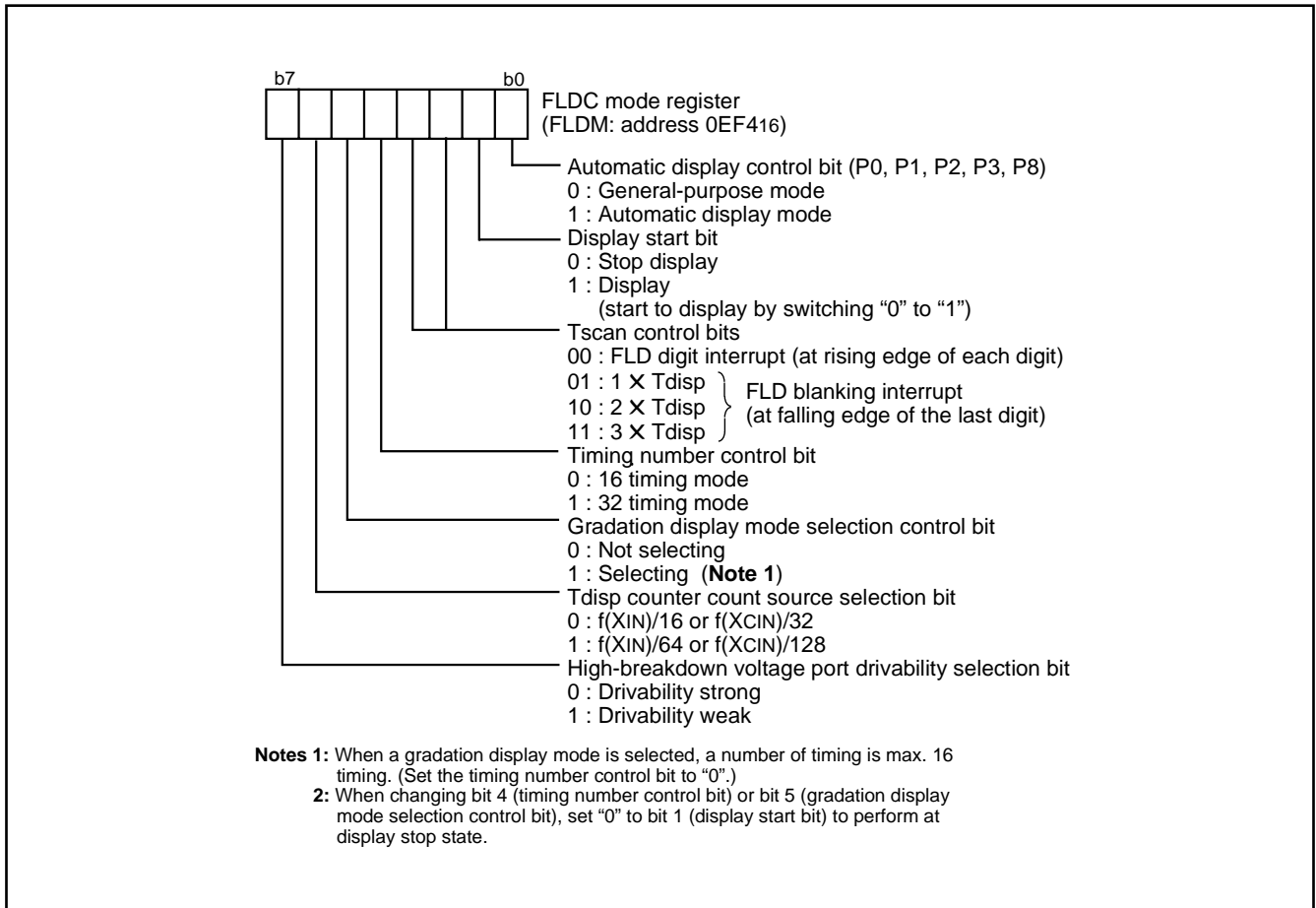

Fig. 43 Structure of FLDC mode register

**FLD Automatic Display Pins**

When the automatic display control bits of the FLDC mode register (address 0EF416) are set to "1," the ports of P0, P1, P2, P3 and P8 are used as FLD automatic display pins.

When using the FLD automatic display mode, set each port to the FLD pin or the general-purpose port using the respective switch register in accordance with the number of segments and the number of digits.

This setting is performed by writing a value into the FLD/port switch register (addresses 0EF916 to 0EFB16) of each port.

This setting can be performed in units of bit. When "0" is set, the port is set to the general-purpose port. When "1" is set, the port is set to the FLD pin. There is no restriction on whether the FLD pin is to be used as a segment pin or a digit pin.

**Table 9 Pins in FLD automatic display mode**

Port Name	Automatic Display Pins	Setting Method
P0, P2, P80–P83	FLD0–FLD15 FLD32–FLD35	The individual bits of the FLD/port switch register (addresses 0EF916–0EFB16) can be set each pin either FLD port ("1") or general-purpose port ("0").
P1, P3	FLD16–FLD31	None (FLD only)
P84–P87	FLD36–FLD39	The individual bits of the FLD/port switch register (address 0EFB16) can be set each pin to either FLD port ("1") or general-purpose port ("0"). The output can be reversed by the port P8 FLD output control register (address 0EFC16). The port output format is the CMOS output format. When using the port as a display pin, a driver must be installed externally.

	Setting example 1 Number of segments 15 Number of digits 8	Setting example 2 25 15	Setting example 3 18 20	Setting example 4 16 10																																																																
Port P2	<table border="1"> <tr><td>0</td><td>P20</td></tr> <tr><td>0</td><td>P21</td></tr> <tr><td>0</td><td>P22</td></tr> <tr><td>0</td><td>P23</td></tr> <tr><td>0</td><td>P24</td></tr> <tr><td>0</td><td>P25</td></tr> <tr><td>0</td><td>P26</td></tr> <tr><td>0</td><td>P27</td></tr> </table>	0	P20	0	P21	0	P22	0	P23	0	P24	0	P25	0	P26	0	P27	<table border="1"> <tr><td>1</td><td>FLD0(SEG1)</td></tr> <tr><td>1</td><td>FLD1(SEG2)</td></tr> <tr><td>1</td><td>FLD2(SEG3)</td></tr> <tr><td>1</td><td>FLD3(SEG4)</td></tr> <tr><td>1</td><td>FLD4(SEG5)</td></tr> <tr><td>1</td><td>FLD5(SEG6)</td></tr> <tr><td>1</td><td>FLD6(SEG7)</td></tr> <tr><td>1</td><td>FLD7(SEG8)</td></tr> </table>	1	FLD0(SEG1)	1	FLD1(SEG2)	1	FLD2(SEG3)	1	FLD3(SEG4)	1	FLD4(SEG5)	1	FLD5(SEG6)	1	FLD6(SEG7)	1	FLD7(SEG8)	<table border="1"> <tr><td>0</td><td>P20</td></tr> <tr><td>0</td><td>P21</td></tr> <tr><td>1</td><td>FLD2(SEG1)</td></tr> <tr><td>1</td><td>FLD3(SEG2)</td></tr> <tr><td>1</td><td>FLD4(SEG3)</td></tr> <tr><td>1</td><td>FLD5(SEG4)</td></tr> <tr><td>1</td><td>FLD6(SEG5)</td></tr> <tr><td>1</td><td>FLD7(SEG6)</td></tr> </table>	0	P20	0	P21	1	FLD2(SEG1)	1	FLD3(SEG2)	1	FLD4(SEG3)	1	FLD5(SEG4)	1	FLD6(SEG5)	1	FLD7(SEG6)	<table border="1"> <tr><td>0</td><td>P20</td></tr> <tr><td>0</td><td>P21</td></tr> <tr><td>0</td><td>P22</td></tr> <tr><td>0</td><td>P23</td></tr> <tr><td>0</td><td>P24</td></tr> <tr><td>0</td><td>P25</td></tr> <tr><td>1</td><td>FLD4(SEG1)</td></tr> <tr><td>1</td><td>FLD5(SEG2)</td></tr> </table>	0	P20	0	P21	0	P22	0	P23	0	P24	0	P25	1	FLD4(SEG1)	1	FLD5(SEG2)
0	P20																																																																			
0	P21																																																																			
0	P22																																																																			
0	P23																																																																			
0	P24																																																																			
0	P25																																																																			
0	P26																																																																			
0	P27																																																																			
1	FLD0(SEG1)																																																																			
1	FLD1(SEG2)																																																																			
1	FLD2(SEG3)																																																																			
1	FLD3(SEG4)																																																																			
1	FLD4(SEG5)																																																																			
1	FLD5(SEG6)																																																																			
1	FLD6(SEG7)																																																																			
1	FLD7(SEG8)																																																																			
0	P20																																																																			
0	P21																																																																			
1	FLD2(SEG1)																																																																			
1	FLD3(SEG2)																																																																			
1	FLD4(SEG3)																																																																			
1	FLD5(SEG4)																																																																			
1	FLD6(SEG5)																																																																			
1	FLD7(SEG6)																																																																			
0	P20																																																																			
0	P21																																																																			
0	P22																																																																			
0	P23																																																																			
0	P24																																																																			
0	P25																																																																			
1	FLD4(SEG1)																																																																			
1	FLD5(SEG2)																																																																			
Port P0	<table border="1"> <tr><td>1</td><td>FLD8(SEG1)</td></tr> <tr><td>0</td><td>P01</td></tr> <tr><td>0</td><td>P02</td></tr> <tr><td>0</td><td>P03</td></tr> <tr><td>0</td><td>P04</td></tr> <tr><td>0</td><td>P05</td></tr> <tr><td>1</td><td>FLD14(SEG2)</td></tr> <tr><td>1</td><td>FLD15(SEG3)</td></tr> </table>	1	FLD8(SEG1)	0	P01	0	P02	0	P03	0	P04	0	P05	1	FLD14(SEG2)	1	FLD15(SEG3)	<table border="1"> <tr><td>1</td><td>FLD8(SEG9)</td></tr> <tr><td>1</td><td>FLD9(SEG10)</td></tr> <tr><td>1</td><td>FLD10(SEG11)</td></tr> <tr><td>1</td><td>FLD11(SEG12)</td></tr> <tr><td>1</td><td>FLD12(SEG13)</td></tr> <tr><td>1</td><td>FLD13(SEG14)</td></tr> <tr><td>1</td><td>FLD14(SEG15)</td></tr> <tr><td>1</td><td>FLD15(SEG16)</td></tr> </table>	1	FLD8(SEG9)	1	FLD9(SEG10)	1	FLD10(SEG11)	1	FLD11(SEG12)	1	FLD12(SEG13)	1	FLD13(SEG14)	1	FLD14(SEG15)	1	FLD15(SEG16)	<table border="1"> <tr><td>1</td><td>FLD8(DIG1)</td></tr> <tr><td>1</td><td>FLD9(DIG2)</td></tr> <tr><td>1</td><td>FLD10(DIG3)</td></tr> <tr><td>1</td><td>FLD11(DIG4)</td></tr> <tr><td>1</td><td>FLD12(DIG5)</td></tr> <tr><td>1</td><td>FLD13(DIG6)</td></tr> <tr><td>1</td><td>FLD14(DIG7)</td></tr> <tr><td>1</td><td>FLD15(DIG8)</td></tr> </table>	1	FLD8(DIG1)	1	FLD9(DIG2)	1	FLD10(DIG3)	1	FLD11(DIG4)	1	FLD12(DIG5)	1	FLD13(DIG6)	1	FLD14(DIG7)	1	FLD15(DIG8)	<table border="1"> <tr><td>1</td><td>FLD6(SEG3)</td></tr> <tr><td>1</td><td>FLD7(SEG4)</td></tr> <tr><td>1</td><td>FLD8(SEG5)</td></tr> <tr><td>1</td><td>FLD9(SEG6)</td></tr> <tr><td>1</td><td>FLD10(SEG7)</td></tr> <tr><td>1</td><td>FLD11(SEG8)</td></tr> <tr><td>1</td><td>FLD12(SEG9)</td></tr> <tr><td>1</td><td>FLD13(SEG10)</td></tr> </table>	1	FLD6(SEG3)	1	FLD7(SEG4)	1	FLD8(SEG5)	1	FLD9(SEG6)	1	FLD10(SEG7)	1	FLD11(SEG8)	1	FLD12(SEG9)	1	FLD13(SEG10)
1	FLD8(SEG1)																																																																			
0	P01																																																																			
0	P02																																																																			
0	P03																																																																			
0	P04																																																																			
0	P05																																																																			
1	FLD14(SEG2)																																																																			
1	FLD15(SEG3)																																																																			
1	FLD8(SEG9)																																																																			
1	FLD9(SEG10)																																																																			
1	FLD10(SEG11)																																																																			
1	FLD11(SEG12)																																																																			
1	FLD12(SEG13)																																																																			
1	FLD13(SEG14)																																																																			
1	FLD14(SEG15)																																																																			
1	FLD15(SEG16)																																																																			
1	FLD8(DIG1)																																																																			
1	FLD9(DIG2)																																																																			
1	FLD10(DIG3)																																																																			
1	FLD11(DIG4)																																																																			
1	FLD12(DIG5)																																																																			
1	FLD13(DIG6)																																																																			
1	FLD14(DIG7)																																																																			
1	FLD15(DIG8)																																																																			
1	FLD6(SEG3)																																																																			
1	FLD7(SEG4)																																																																			
1	FLD8(SEG5)																																																																			
1	FLD9(SEG6)																																																																			
1	FLD10(SEG7)																																																																			
1	FLD11(SEG8)																																																																			
1	FLD12(SEG9)																																																																			
1	FLD13(SEG10)																																																																			
Port P1	<table border="1"> <tr><td>FLD16(DIG1)</td><td>1</td></tr> <tr><td>FLD17(DIG2)</td><td>1</td></tr> <tr><td>FLD18(DIG3)</td><td>1</td></tr> <tr><td>FLD19(DIG4)</td><td>1</td></tr> <tr><td>FLD20(SEG4)</td><td>0</td></tr> <tr><td>FLD21(SEG5)</td><td>0</td></tr> <tr><td>FLD22(SEG6)</td><td>0</td></tr> <tr><td>FLD23(SEG7)</td><td>0</td></tr> </table>	FLD16(DIG1)	1	FLD17(DIG2)	1	FLD18(DIG3)	1	FLD19(DIG4)	1	FLD20(SEG4)	0	FLD21(SEG5)	0	FLD22(SEG6)	0	FLD23(SEG7)	0	<table border="1"> <tr><td>FLD16(DIG1)</td><td>1</td></tr> <tr><td>FLD17(DIG2)</td><td>1</td></tr> <tr><td>FLD18(DIG3)</td><td>1</td></tr> <tr><td>FLD19(DIG4)</td><td>1</td></tr> <tr><td>FLD20(DIG5)</td><td>1</td></tr> <tr><td>FLD21(DIG6)</td><td>1</td></tr> <tr><td>FLD22(DIG7)</td><td>1</td></tr> <tr><td>FLD23(DIG8)</td><td>1</td></tr> </table>	FLD16(DIG1)	1	FLD17(DIG2)	1	FLD18(DIG3)	1	FLD19(DIG4)	1	FLD20(DIG5)	1	FLD21(DIG6)	1	FLD22(DIG7)	1	FLD23(DIG8)	1	<table border="1"> <tr><td>FLD16(DIG9)</td><td>1</td></tr> <tr><td>FLD17(DIG10)</td><td>1</td></tr> <tr><td>FLD18(DIG11)</td><td>1</td></tr> <tr><td>FLD19(DIG12)</td><td>1</td></tr> <tr><td>FLD20(DIG13)</td><td>1</td></tr> <tr><td>FLD21(DIG14)</td><td>1</td></tr> <tr><td>FLD22(DIG15)</td><td>1</td></tr> <tr><td>FLD23(DIG16)</td><td>1</td></tr> </table>	FLD16(DIG9)	1	FLD17(DIG10)	1	FLD18(DIG11)	1	FLD19(DIG12)	1	FLD20(DIG13)	1	FLD21(DIG14)	1	FLD22(DIG15)	1	FLD23(DIG16)	1	<table border="1"> <tr><td>FLD16(DIG1)</td><td>1</td></tr> <tr><td>FLD17(DIG2)</td><td>1</td></tr> <tr><td>FLD18(DIG3)</td><td>1</td></tr> <tr><td>FLD19(DIG4)</td><td>1</td></tr> <tr><td>FLD20(DIG5)</td><td>1</td></tr> <tr><td>FLD21(DIG6)</td><td>1</td></tr> <tr><td>FLD22(DIG7)</td><td>1</td></tr> <tr><td>FLD23(DIG8)</td><td>1</td></tr> </table>	FLD16(DIG1)	1	FLD17(DIG2)	1	FLD18(DIG3)	1	FLD19(DIG4)	1	FLD20(DIG5)	1	FLD21(DIG6)	1	FLD22(DIG7)	1	FLD23(DIG8)	1
FLD16(DIG1)	1																																																																			
FLD17(DIG2)	1																																																																			
FLD18(DIG3)	1																																																																			
FLD19(DIG4)	1																																																																			
FLD20(SEG4)	0																																																																			
FLD21(SEG5)	0																																																																			
FLD22(SEG6)	0																																																																			
FLD23(SEG7)	0																																																																			
FLD16(DIG1)	1																																																																			
FLD17(DIG2)	1																																																																			
FLD18(DIG3)	1																																																																			
FLD19(DIG4)	1																																																																			
FLD20(DIG5)	1																																																																			
FLD21(DIG6)	1																																																																			
FLD22(DIG7)	1																																																																			
FLD23(DIG8)	1																																																																			
FLD16(DIG9)	1																																																																			
FLD17(DIG10)	1																																																																			
FLD18(DIG11)	1																																																																			
FLD19(DIG12)	1																																																																			
FLD20(DIG13)	1																																																																			
FLD21(DIG14)	1																																																																			
FLD22(DIG15)	1																																																																			
FLD23(DIG16)	1																																																																			
FLD16(DIG1)	1																																																																			
FLD17(DIG2)	1																																																																			
FLD18(DIG3)	1																																																																			
FLD19(DIG4)	1																																																																			
FLD20(DIG5)	1																																																																			
FLD21(DIG6)	1																																																																			
FLD22(DIG7)	1																																																																			
FLD23(DIG8)	1																																																																			
Port P3	<table border="1"> <tr><td>FLD24(SEG8)</td><td>0</td></tr> <tr><td>FLD25(SEG9)</td><td>0</td></tr> <tr><td>FLD26(SEG10)</td><td>0</td></tr> <tr><td>FLD27(SEG11)</td><td>0</td></tr> <tr><td>FLD28(DIG5)</td><td>1</td></tr> <tr><td>FLD29(DIG6)</td><td>1</td></tr> <tr><td>FLD30(DIG7)</td><td>1</td></tr> <tr><td>FLD31(DIG8)</td><td>1</td></tr> </table>	FLD24(SEG8)	0	FLD25(SEG9)	0	FLD26(SEG10)	0	FLD27(SEG11)	0	FLD28(DIG5)	1	FLD29(DIG6)	1	FLD30(DIG7)	1	FLD31(DIG8)	1	<table border="1"> <tr><td>FLD24(DIG9)</td><td>1</td></tr> <tr><td>FLD25(DIG10)</td><td>1</td></tr> <tr><td>FLD26(DIG11)</td><td>1</td></tr> <tr><td>FLD27(DIG12)</td><td>1</td></tr> <tr><td>FLD28(DIG13)</td><td>1</td></tr> <tr><td>FLD29(DIG14)</td><td>1</td></tr> <tr><td>FLD30(DIG15)</td><td>1</td></tr> <tr><td>FLD31(SEG17)</td><td>0</td></tr> </table>	FLD24(DIG9)	1	FLD25(DIG10)	1	FLD26(DIG11)	1	FLD27(DIG12)	1	FLD28(DIG13)	1	FLD29(DIG14)	1	FLD30(DIG15)	1	FLD31(SEG17)	0	<table border="1"> <tr><td>FLD24(DIG17)</td><td>1</td></tr> <tr><td>FLD25(DIG18)</td><td>1</td></tr> <tr><td>FLD26(DIG19)</td><td>1</td></tr> <tr><td>FLD27(DIG20)</td><td>1</td></tr> <tr><td>FLD28(SEG7)</td><td>0</td></tr> <tr><td>FLD29(SEG8)</td><td>0</td></tr> <tr><td>FLD30(SEG9)</td><td>0</td></tr> <tr><td>FLD31(SEG10)</td><td>0</td></tr> </table>	FLD24(DIG17)	1	FLD25(DIG18)	1	FLD26(DIG19)	1	FLD27(DIG20)	1	FLD28(SEG7)	0	FLD29(SEG8)	0	FLD30(SEG9)	0	FLD31(SEG10)	0	<table border="1"> <tr><td>FLD24(DIG9)</td><td>1</td></tr> <tr><td>FLD25(DIG10)</td><td>1</td></tr> <tr><td>FLD14(SEG11)</td><td>0</td></tr> <tr><td>FLD15(SEG12)</td><td>0</td></tr> <tr><td>FLD26(SEG13)</td><td>0</td></tr> <tr><td>FLD27(SEG14)</td><td>0</td></tr> <tr><td>FLD28(SEG15)</td><td>0</td></tr> <tr><td>FLD29(SEG16)</td><td>0</td></tr> </table>	FLD24(DIG9)	1	FLD25(DIG10)	1	FLD14(SEG11)	0	FLD15(SEG12)	0	FLD26(SEG13)	0	FLD27(SEG14)	0	FLD28(SEG15)	0	FLD29(SEG16)	0
FLD24(SEG8)	0																																																																			
FLD25(SEG9)	0																																																																			
FLD26(SEG10)	0																																																																			
FLD27(SEG11)	0																																																																			
FLD28(DIG5)	1																																																																			
FLD29(DIG6)	1																																																																			
FLD30(DIG7)	1																																																																			
FLD31(DIG8)	1																																																																			
FLD24(DIG9)	1																																																																			
FLD25(DIG10)	1																																																																			
FLD26(DIG11)	1																																																																			
FLD27(DIG12)	1																																																																			
FLD28(DIG13)	1																																																																			
FLD29(DIG14)	1																																																																			
FLD30(DIG15)	1																																																																			
FLD31(SEG17)	0																																																																			
FLD24(DIG17)	1																																																																			
FLD25(DIG18)	1																																																																			
FLD26(DIG19)	1																																																																			
FLD27(DIG20)	1																																																																			
FLD28(SEG7)	0																																																																			
FLD29(SEG8)	0																																																																			
FLD30(SEG9)	0																																																																			
FLD31(SEG10)	0																																																																			
FLD24(DIG9)	1																																																																			
FLD25(DIG10)	1																																																																			
FLD14(SEG11)	0																																																																			
FLD15(SEG12)	0																																																																			
FLD26(SEG13)	0																																																																			
FLD27(SEG14)	0																																																																			
FLD28(SEG15)	0																																																																			
FLD29(SEG16)	0																																																																			
Port P8	<table border="1"> <tr><td>1</td><td>FLD32(SEG12)</td></tr> <tr><td>1</td><td>FLD33(SEG13)</td></tr> <tr><td>1</td><td>FLD34(SEG14)</td></tr> <tr><td>1</td><td>FLD35(SEG15)</td></tr> <tr><td>0</td><td>P84</td></tr> <tr><td>0</td><td>P85</td></tr> <tr><td>0</td><td>P86</td></tr> <tr><td>0</td><td>P87</td></tr> </table>	1	FLD32(SEG12)	1	FLD33(SEG13)	1	FLD34(SEG14)	1	FLD35(SEG15)	0	P84	0	P85	0	P86	0	P87	<table border="1"> <tr><td>1</td><td>FLD32(SEG18)</td></tr> <tr><td>1</td><td>FLD33(SEG19)</td></tr> <tr><td>1</td><td>FLD34(SEG20)</td></tr> <tr><td>1</td><td>FLD35(SEG21)</td></tr> <tr><td>1</td><td>FLD36(SEG22)</td></tr> <tr><td>1</td><td>FLD37(SEG23)</td></tr> <tr><td>1</td><td>FLD38(SEG24)</td></tr> <tr><td>1</td><td>FLD39(SEG25)</td></tr> </table>	1	FLD32(SEG18)	1	FLD33(SEG19)	1	FLD34(SEG20)	1	FLD35(SEG21)	1	FLD36(SEG22)	1	FLD37(SEG23)	1	FLD38(SEG24)	1	FLD39(SEG25)	<table border="1"> <tr><td>1</td><td>FLD32(SEG11)</td></tr> <tr><td>1</td><td>FLD33(SEG12)</td></tr> <tr><td>1</td><td>FLD34(SEG13)</td></tr> <tr><td>1</td><td>FLD35(SEG14)</td></tr> <tr><td>1</td><td>FLD36(SEG15)</td></tr> <tr><td>1</td><td>FLD37(SEG16)</td></tr> <tr><td>1</td><td>FLD38(SEG17)</td></tr> <tr><td>1</td><td>FLD39(SEG18)</td></tr> </table>	1	FLD32(SEG11)	1	FLD33(SEG12)	1	FLD34(SEG13)	1	FLD35(SEG14)	1	FLD36(SEG15)	1	FLD37(SEG16)	1	FLD38(SEG17)	1	FLD39(SEG18)	<table border="1"> <tr><td>0</td><td>P80</td></tr> <tr><td>0</td><td>P81</td></tr> <tr><td>0</td><td>P82</td></tr> <tr><td>0</td><td>P83</td></tr> <tr><td>0</td><td>P84</td></tr> <tr><td>0</td><td>P85</td></tr> <tr><td>0</td><td>P86</td></tr> <tr><td>0</td><td>P87</td></tr> </table>	0	P80	0	P81	0	P82	0	P83	0	P84	0	P85	0	P86	0	P87
1	FLD32(SEG12)																																																																			
1	FLD33(SEG13)																																																																			
1	FLD34(SEG14)																																																																			
1	FLD35(SEG15)																																																																			
0	P84																																																																			
0	P85																																																																			
0	P86																																																																			
0	P87																																																																			
1	FLD32(SEG18)																																																																			
1	FLD33(SEG19)																																																																			
1	FLD34(SEG20)																																																																			
1	FLD35(SEG21)																																																																			
1	FLD36(SEG22)																																																																			
1	FLD37(SEG23)																																																																			
1	FLD38(SEG24)																																																																			
1	FLD39(SEG25)																																																																			
1	FLD32(SEG11)																																																																			
1	FLD33(SEG12)																																																																			
1	FLD34(SEG13)																																																																			
1	FLD35(SEG14)																																																																			
1	FLD36(SEG15)																																																																			
1	FLD37(SEG16)																																																																			
1	FLD38(SEG17)																																																																			
1	FLD39(SEG18)																																																																			
0	P80																																																																			
0	P81																																																																			
0	P82																																																																			
0	P83																																																																			
0	P84																																																																			
0	P85																																																																			
0	P86																																																																			
0	P87																																																																			

↑ Value of FLD/port switch register

↑ Value of FLDRAM write disable register  
If data is set to "1", data is protected.  
This setting does not decide the FLD port function (SEG/DIG).

**Fig. 44 Segment/Digit setting example**

**FLD Automatic Display RAM**

The FLD automatic display RAM uses the 160 bytes of addresses 0F60<sub>16</sub> to 0FFF<sub>16</sub>. For FLD, the 3 modes of 16-timing ordinary mode, 16-timing gradation display mode and 32-timing mode are available depending on the number of timings and the presence/absence of gradation display.

The automatic display RAM in each mode is as follows:

**(1) 16-timing ordinary mode**

The 80 bytes of addresses 0FB0<sub>16</sub> to 0FFF<sub>16</sub> are used as a FLD display data store area. Because addresses 0F60<sub>16</sub> to 0FAF<sub>16</sub> are not used as the automatic display RAM, they can be the ordinary RAM or serial I/O automatic transfer RAM.

**(2) 16-timing gradation display mode**

The 160 bytes of addresses 0F60<sub>16</sub> to 0FFF<sub>16</sub> are used. The 80 bytes of addresses 0FB0<sub>16</sub> to 0FFF<sub>16</sub> are used as an FLD display data store area, while the 80 bytes of addresses 0F60<sub>16</sub> to 0FAF<sub>16</sub> are used as a gradation display control data store area.

**(3) 32-timing mode**

The 160 bytes of addresses 0F60<sub>16</sub> to 0FFF<sub>16</sub> are used as an FLD display data store area.

**[FLD Data Pointer and FLD Data Pointer Reload Register] FLDDP (0EF8<sub>16</sub>)**

Both the FLD data pointer and FLD data pointer reload register are 8-bit registers assigned at address 0EF8<sub>16</sub>. When writing data to this address, the data is written to the FLD data pointer reload register; when reading data from this address, the value in the FLD data pointer is read.

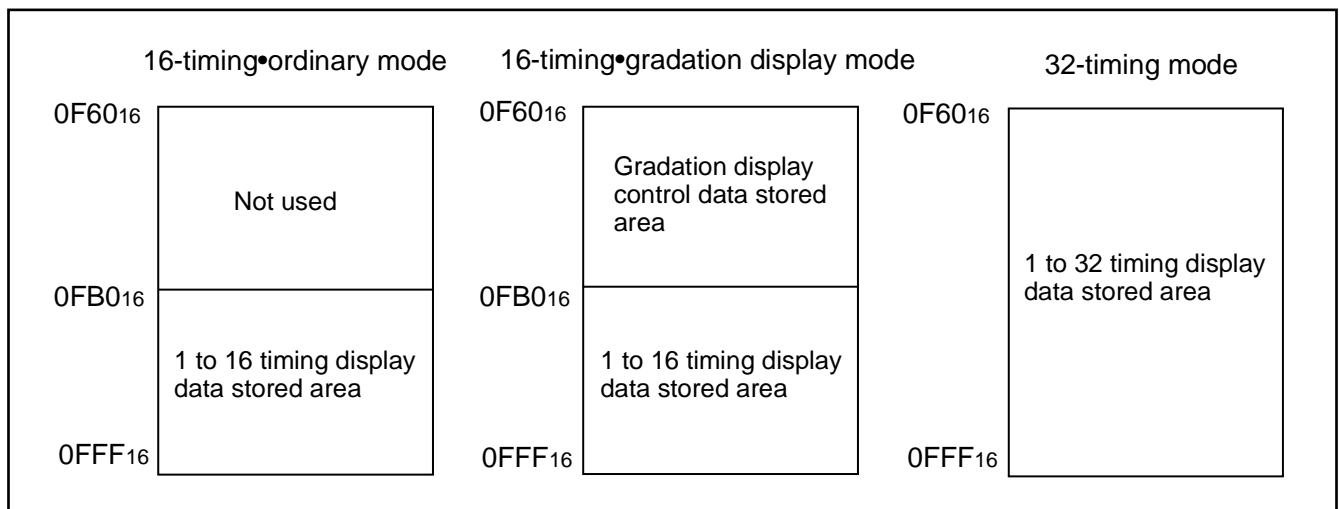

Fig. 45 FLD automatic display RAM assignment

**Data Setup**

**(1) 16-timing•ordinary mode**

The area of addresses 0FB0<sub>16</sub> to 0FFF<sub>16</sub> are used as a FLD automatic display RAM.

When data is stored in the FLD automatic display RAM, the last data of FLD port P2 is stored at address 0FB0<sub>16</sub>, the last data of FLD port P0 is stored at address 0FC0<sub>16</sub>, the last data of FLD port P1 is stored at address 0FD0<sub>16</sub>, the last data of FLD port P3 is stored at address 0FE0<sub>16</sub>, and the last data of FLD port P8 is stored at address 0FF0<sub>16</sub>, to assign in sequence from the last data respectively.

The first data of the FLD port P2, P0, P1, P3, and P8 is stored at an address which adds the value of (the timing number - 1) to the corresponding address 0FB0<sub>16</sub>, 0FC0<sub>16</sub>, 0FD0<sub>16</sub>, 0FE0<sub>16</sub>, and 0FF0<sub>16</sub>.

Set the FLD data pointer reload register to the value given by the timing number - 1. "1" is always written to bits 7, 6, and 5. Note that "0" is always read from bits 7, 6, and 5 when reading. "1" is always set to bit 4, but this bit become written value when reading.

**(2) 16-timing•gradation display mode**

Display data setting is performed in the same way as that of the 16-timing•ordinary mode. Gradation display control data is arranged at an address resulting from subtracting 0050<sub>16</sub> from the display data store address of each timing and pin. Bright display is performed by setting "0", and dark display is performed by setting "1".

Set the FLD data pointer reload register to the value given by the timing number - 1. "1" is always written to bits 7, 6, and 5. Note that "0" is always read from bits 7, 6, and 5 when reading. "1" is always set to bit 4, but this bit become written value when reading.

**(3) 32-timing mode**

The area of addresses 0F60<sub>16</sub> to 0FFF<sub>16</sub> are used as a FLD automatic display RAM. When data is stored in the FLD automatic display RAM, the last data of FLD port P2 is stored at address 0F60<sub>16</sub>, the last data of FLD port P0 is stored at address 0F80<sub>16</sub>, the last data of FLD port P1 is stored at address 0FA0<sub>16</sub>, the last data of FLD port P3 is stored at address 0FC0<sub>16</sub>, and the last data of FLD port P8 is stored at address 0FE0<sub>16</sub>, to assign in sequence from the last data respectively.

The first data of the FLD port P2, P0, P1, P3, and P8 is stored at an address which adds the value of (the timing number - 1) to the corresponding address 0F60<sub>16</sub>, 0F80<sub>16</sub>, 0FA0<sub>16</sub>, 0FC0<sub>16</sub>, and 0FE0<sub>16</sub>.

Set the FLD data pointer reload register to the value given by the timing number -1. "1" is always written to bits 7, 6, and 5. Note that "0" is always read from bits 7, 6, and 5 when reading.

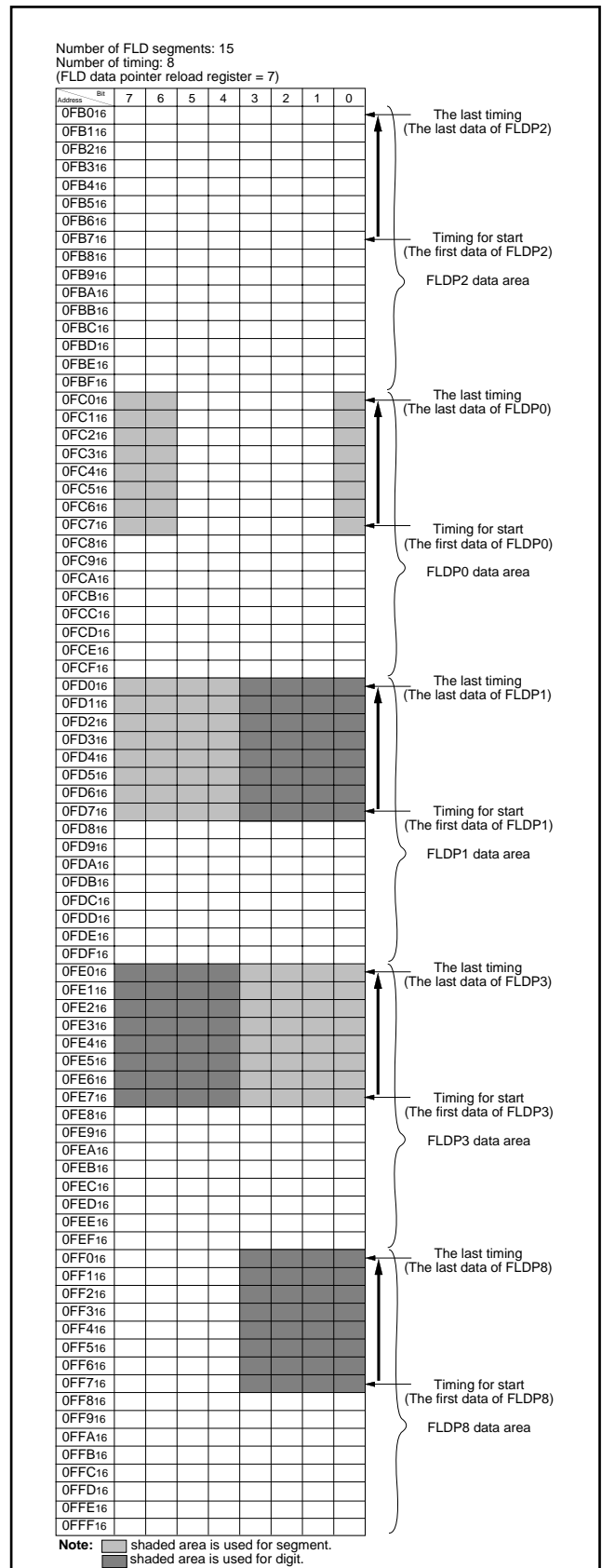

Fig. 46 Example of using FLD automatic display RAM in 16-timing•ordinary mode

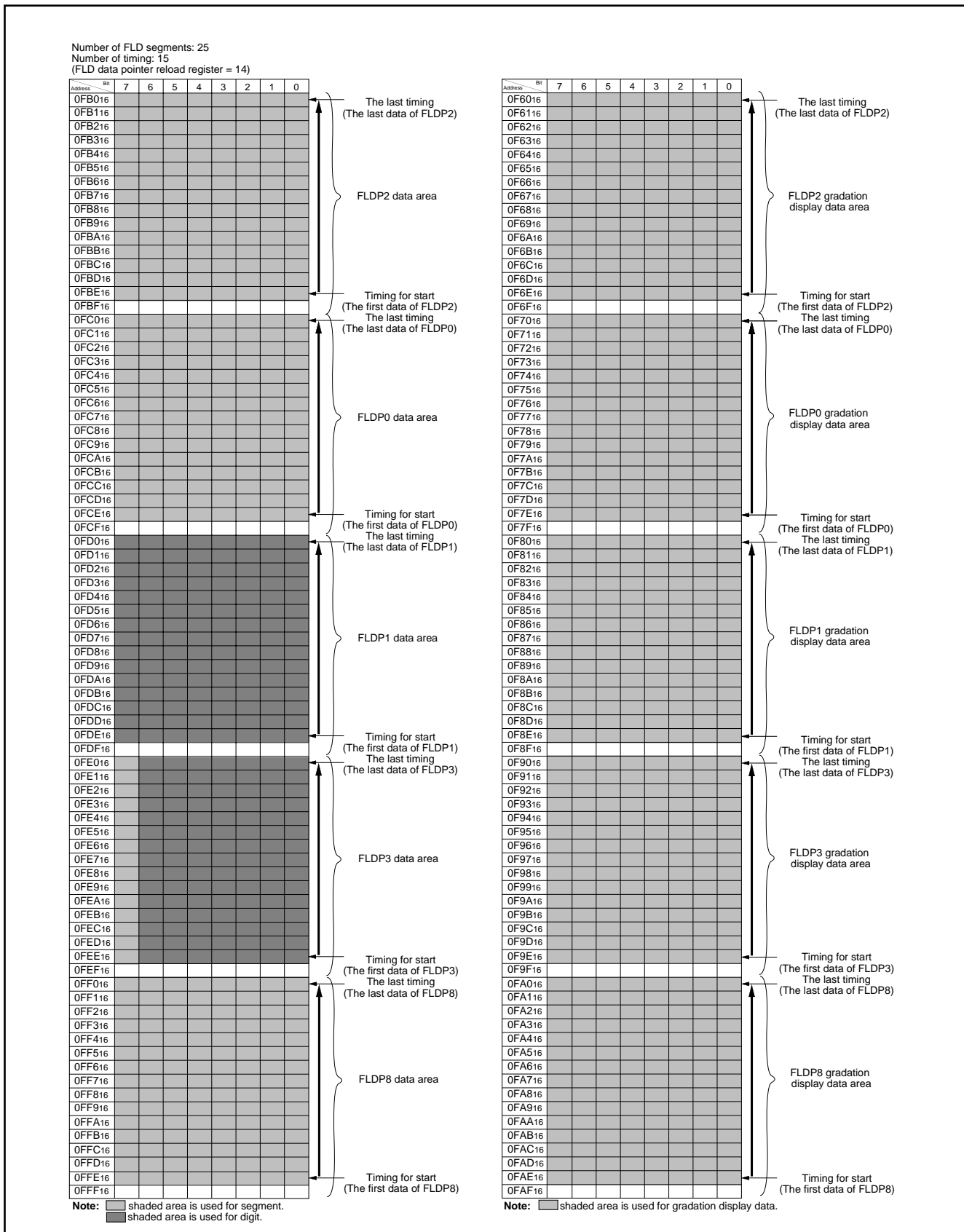

Fig. 47 Example of using FLD automatic display RAM in 16-timing\*gradation display mode

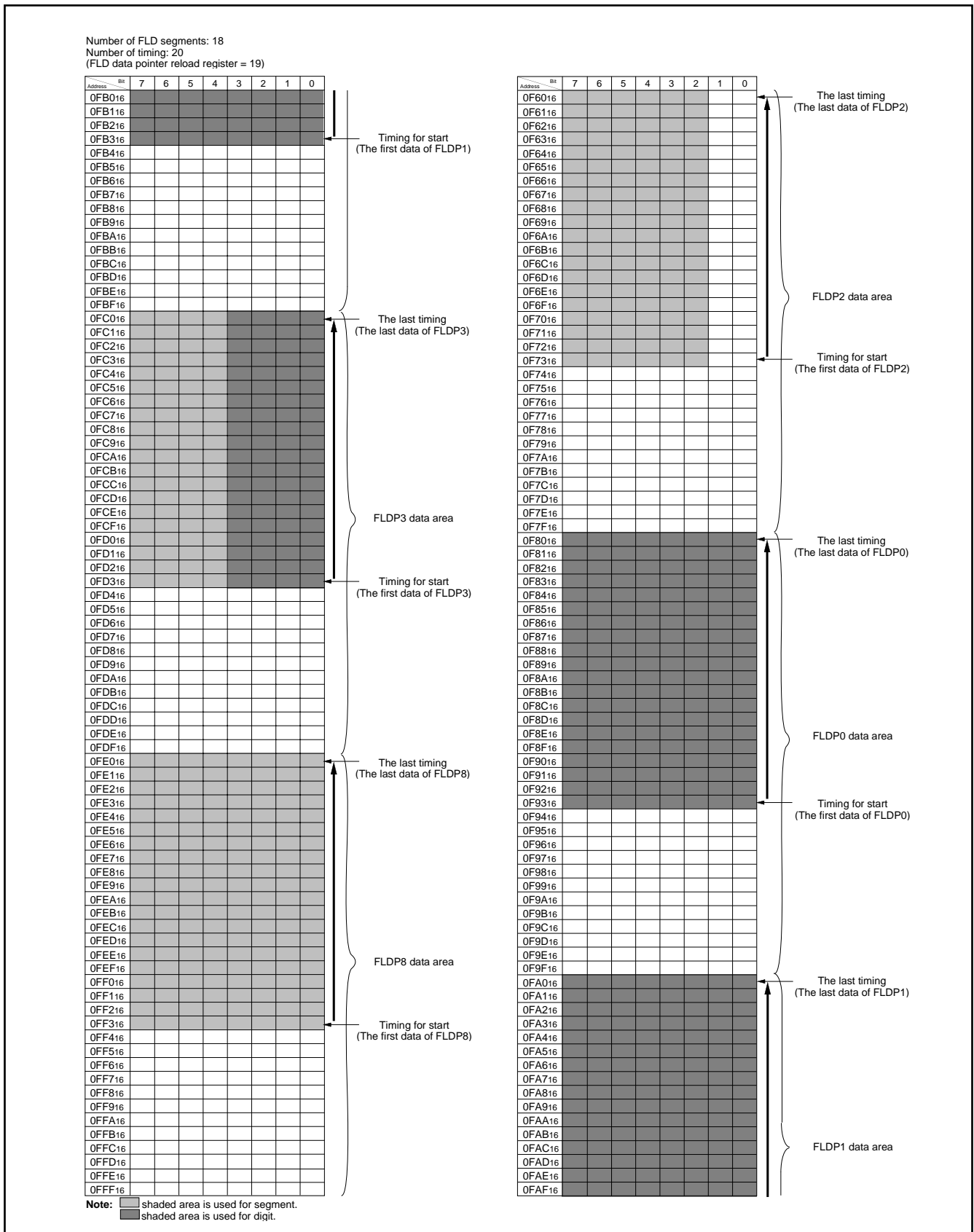

Fig. 48 Example of using FLD automatic display RAM in 32-timing mode

**Setting Method When Using Grid Scan Type FLD**

When using the grid scan type FLD, set "1" in the RAM area corresponding to the digit ports that output "1" at each timing. Set "0" in the RAM area corresponding to the other digit ports.

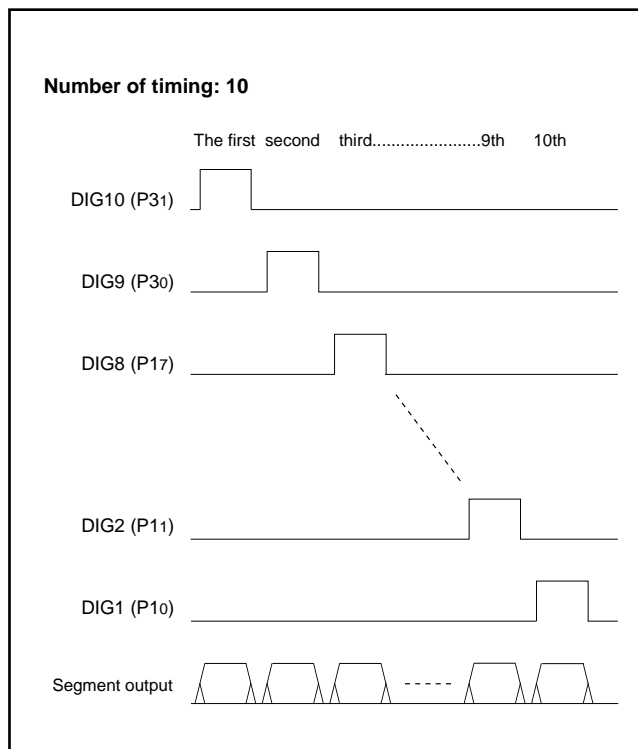

Fig. 49 Example of digit timing using grid scan type

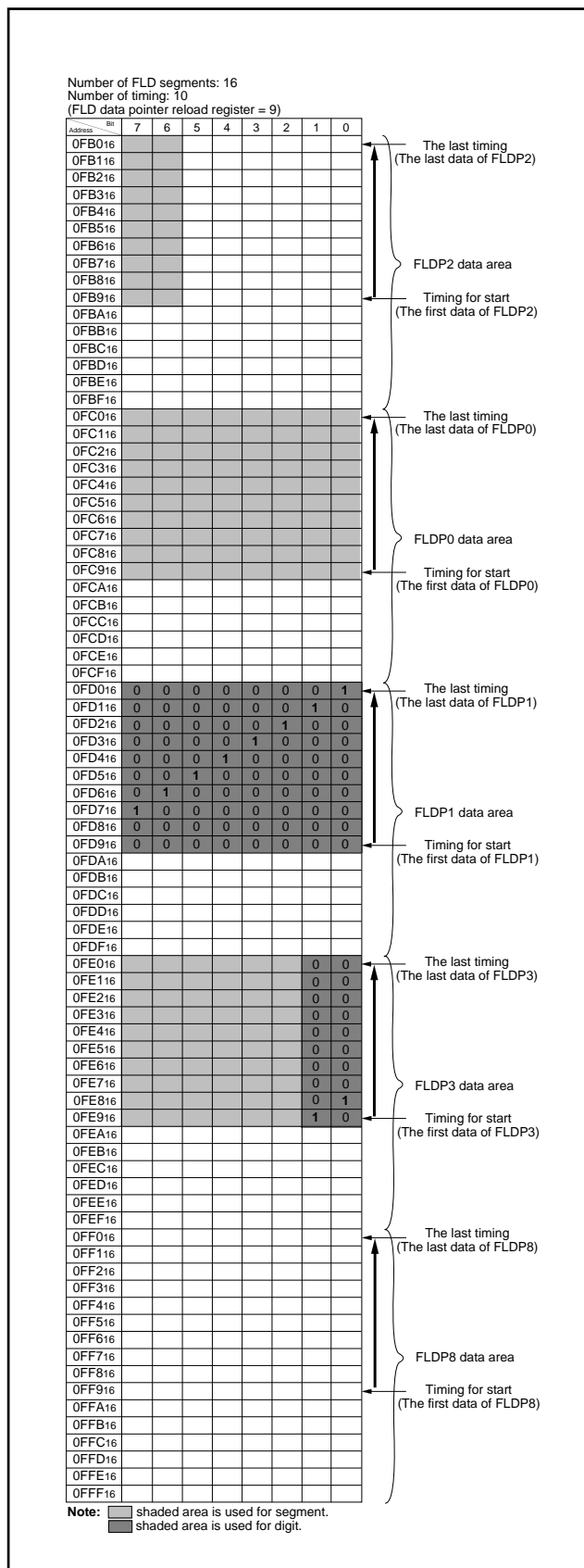

Fig. 50 Example of using FLD automatic display RAM using grid scan type

## Timing Setting

Each timing is set by the FLDC mode register, Tdisp time set register, Toff1 time set register, and Toff2 time set register.

### ●Tdisp time setting

Set the Tdisp time by the Tdisp counter count source selection bit of the FLDC mode register and the Tdisp time set register. Supposing that the value of the Tdisp time set register is  $n$ , the Tdisp time is represented as  $T_{disp} = (n+1) \times t$  ( $t$ : count source synchronization).

When the Tdisp counter count source selection bit of the FLDC mode register is "0" and the value of the Tdisp time set register is 200 (C8<sub>16</sub>), the Tdisp time is:  $T_{disp} = (200+1) \times 4$  (at  $X_{IN} = 4$  MHz) = 804  $\mu$ s. When reading the Tdisp time set register, the value in the counter is read out.

### ●Toff1 time setting

Set the Toff1 time by the Toff1 time set register.

Supposing that the value of the Toff1 time set register is  $n_1$ , the Toff1 time is represented as  $T_{off1} = n_1 \times t$ .

When the Tdisp counter count source selection bit of the FLDC mode register is "0" and the value of the Toff1 time set register is 30 (1E<sub>16</sub>),  $T_{off1} = 30 \times 4$  (at  $X_{IN} = 4$  MHz) = 120  $\mu$ s.

Set a value of 03<sub>16</sub> or more to the Toff1 time set register (address 0EF6<sub>16</sub>).

### ●Toff2 time setting

Set the Toff2 time by the Toff2 time set register.

Supposing that the value of the Toff2 time set register is  $n_2$ , the Toff2 time is represented as  $T_{off2} = n_2 \times t$ .

When the Tdisp counter count source selection bit of the FLDC mode register is "0" and the value of the Toff2 time set register is 180 (B4<sub>16</sub>),  $T_{off2} = 180 \times 4$  (at  $X_{IN} = 4$  MHz) = 720  $\mu$ s.

This Toff2 time setting is valid only for FLD ports which are in the gradation display mode and whose gradation display control RAM value is "1".

When setting "1" to bit 7 of the P8FLD output control register (address 0EFC<sub>16</sub>), set a value of 03<sub>16</sub> or more to the Toff2 time set register (address 0EF7<sub>16</sub>).

## FLD Automatic Display Start

To perform FLD automatic display, set the following registers.

- Port P0FLD/port switch register
- Port P2FLD/port switch register
- Port P8FLD/port switch register
- FLDC mode register
- Tdisp time set register
- Toff1 time set register
- Toff2 time set register
- FLD data pointer

FLD automatic display mode is selected by writing "1" to the bit 0 of the FLDC mode register (address 0EF4<sub>16</sub>), and the automatic display is started by writing "1" to bit 1. During FLD automatic display, bit 1 of the FLDC mode register (address 0EF4<sub>16</sub>) always keeps "1", and FLD automatic display can be interrupted by writing "0" to bit 1.

## Key-scan

When a key-scan is performed with the segment during key-scan blanking period  $T_{scan}$ , take the following sequence:

1. Write "0" to bit 0 of the FLDC mode register (address 0EF4<sub>16</sub>).
2. Set the port corresponding to the segment for key-scan to the output port.
3. Perform the key-scan.
4. After the key-scan is performed, write "1" to bit 0 of FLDC mode register (address 0EF4<sub>16</sub>).

### ■ Note

When performing a key-scan according to the above step 1 to 4, take the following points into consideration.

1. Do not set "0" in bit 1 of the FLDC mode register (address 0EF4<sub>16</sub>).
2. Do not set "1" in the ports corresponding to digits.



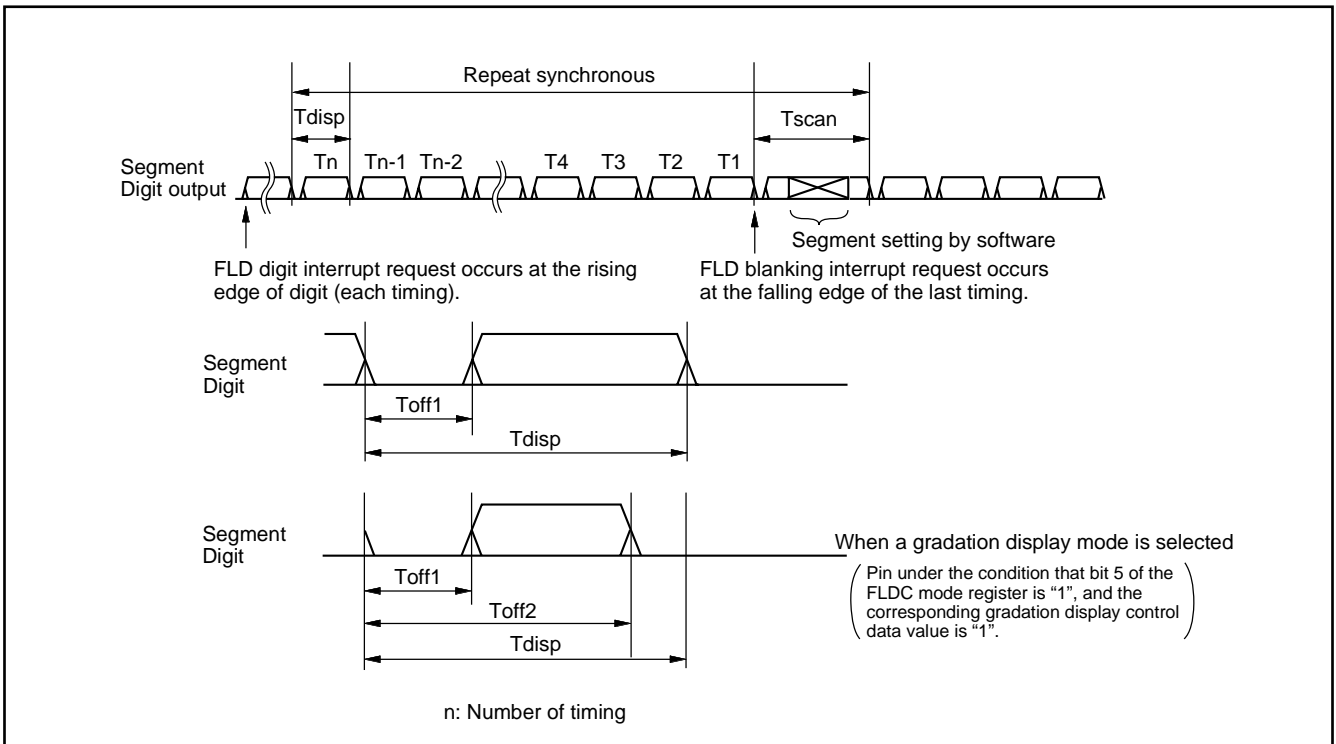

Fig. 51 FLDC timing

**P84 to P87 FLD Output Reverse Function**

P84 to P87 are provided with a function to reverse the polarity of the FLD output. This function is useful in adjusting the polarity when using an externally installed driver.

The output polarity can be reversed by setting "1" to bit 0 of the port P8 FLD output control register.

**P84 to P87 Toff Invalid Function**

P84 to P87 can output waveform in which Toff is invalid, when P84 to P87 is selected FLD ports (See Figure 52).

The function is useful when using a 4 bits →16 bits decoder. The Toff can be invalid by setting "1" to bit 2 of the port P8FLD output control register (address 0EFC16).

**P84 to P87 Output Delay Function**

P84 to P87 can output waveform in which is delayed for 16 μs, when selecting FLD port and selecting Toff invalid function (See Figure 52). When using a 4 bits →16 bits decoder, the function can be useful for prevention of leak radiation caused by phase discrepancy between segment output waveform and digit output waveform. This function can be set by setting "1" to bit 3 of the port P8FLD output control register (address 0EFC16).

**Dimmer Signal Output Function**

P63 can output the dimmer signal. When using a 4 bits →16 bits decoder, the dimmer signal can be used as a control signal for a 4 bits →16 bits decoder. When using M35501FP, the dimmer signal can be used as the CLK signal. The dimmer signal can be output by setting "1" to bit 4 of the port P8FLD output control register (address 0EFC16).

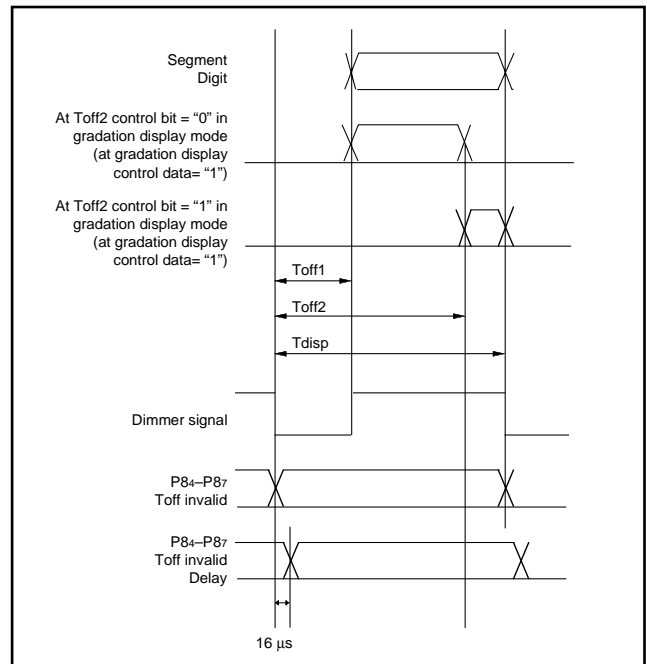

Fig. 52 P84 to P87 FLD output waveform

**Toff2 Control Bit**

The value of the Toff2 time set register is valid when gradation display mode is selected. The FLD ports output (set) the data of display RAM at the end of the Toff1 time and output "0" (reset) at the end of the Toff2 time, when bit 7 of the port P8FLD output control register is "0".

The FLD ports output (set) the data of display RAM at the end of the Toff2 time and output "0" (reset) at the end of Tdisp time, when bit 7 of the port P8FLD output control register is "1".

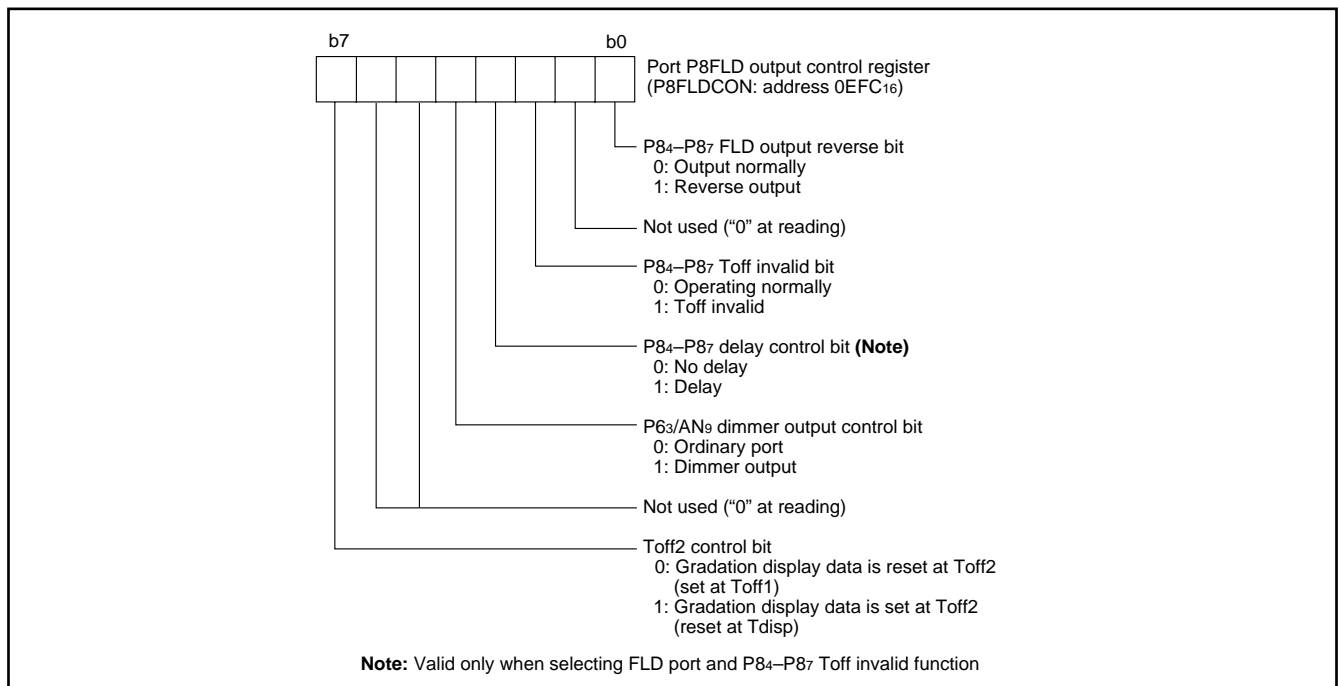

Fig. 53 Structure of port P8 FLD output control register

**A-D CONVERTER**

The 38B4 group has a 10-bit A-D converter. The A-D converter performs successive approximation conversion.

**[A-D Conversion Register] AD**

One of these registers is a high-order register, and the other is a low-order register. The high-order 8 bits of a conversion result is stored in the A-D conversion register (high-order) (address 0034<sub>16</sub>), and the low-order 2 bits of the same result are stored in bit 7 and bit 6 of the A-D conversion register (low-order) (address 0033<sub>16</sub>). During A-D conversion, do not read these registers.

**[A-D Control Register] ADCON**

This register controls A-D converter. Bits 3 to 0 are analog input pin selection bits. Bit 4 is an AD conversion completion bit and "0" during A-D conversion. This bit is set to "1" upon completion of A-D conversion.

A-D conversion is started by setting "0" in this bit.

**[Comparison Voltage Generator]**

The comparison voltage generator divides the voltage between AV<sub>SS</sub> and V<sub>REF</sub>, and outputs the divided voltages.

**[Channel Selector]**

The channel selector selects one of the input ports P7<sub>7</sub>/AN<sub>7</sub>–P7<sub>0</sub>/AN<sub>0</sub>, and P6<sub>5</sub>/SSTB<sub>1</sub>/AN<sub>11</sub>–P6<sub>2</sub>/SRDY<sub>1</sub>/AN<sub>8</sub> and inputs it to the comparator.

When port P6<sub>4</sub> is selected as an analog input pin, an external interrupt function (INT4) is invalid.

**[Comparator and Control Circuit]**

The comparator and control circuit compares an analog input voltage with the comparison voltage and stores the result in the A-D conversion register. When an A-D conversion is completed, the control circuit sets the AD conversion completion bit and the AD

conversion interrupt request bit to "1".

Note that the comparator is constructed linked to a capacitor, so set f(X<sub>IN</sub>) to at least 250 kHz during A-D conversion. Use a CPU system clock dividing the main clock X<sub>IN</sub> as the internal system clock.

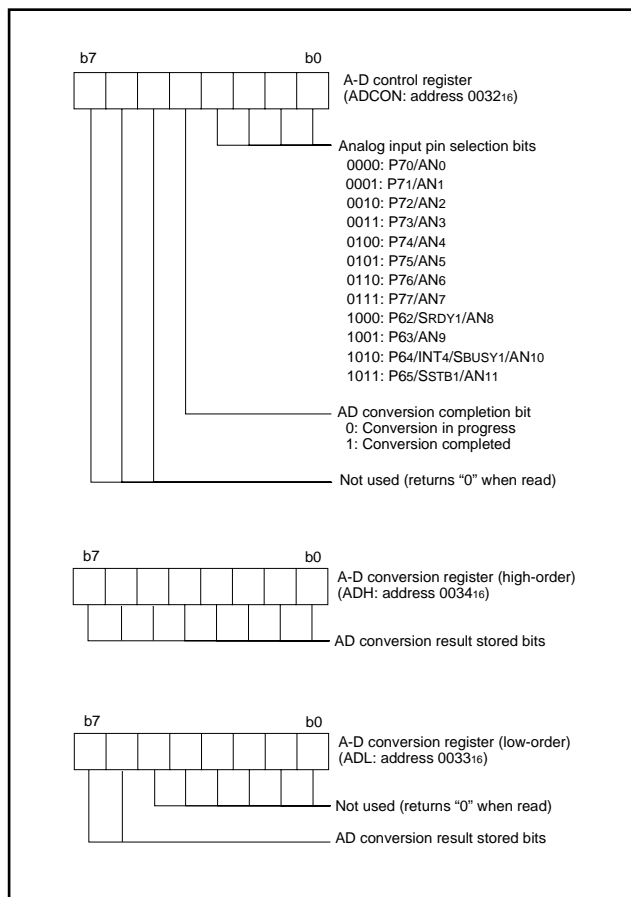

Fig. 54 Structure of A-D control register

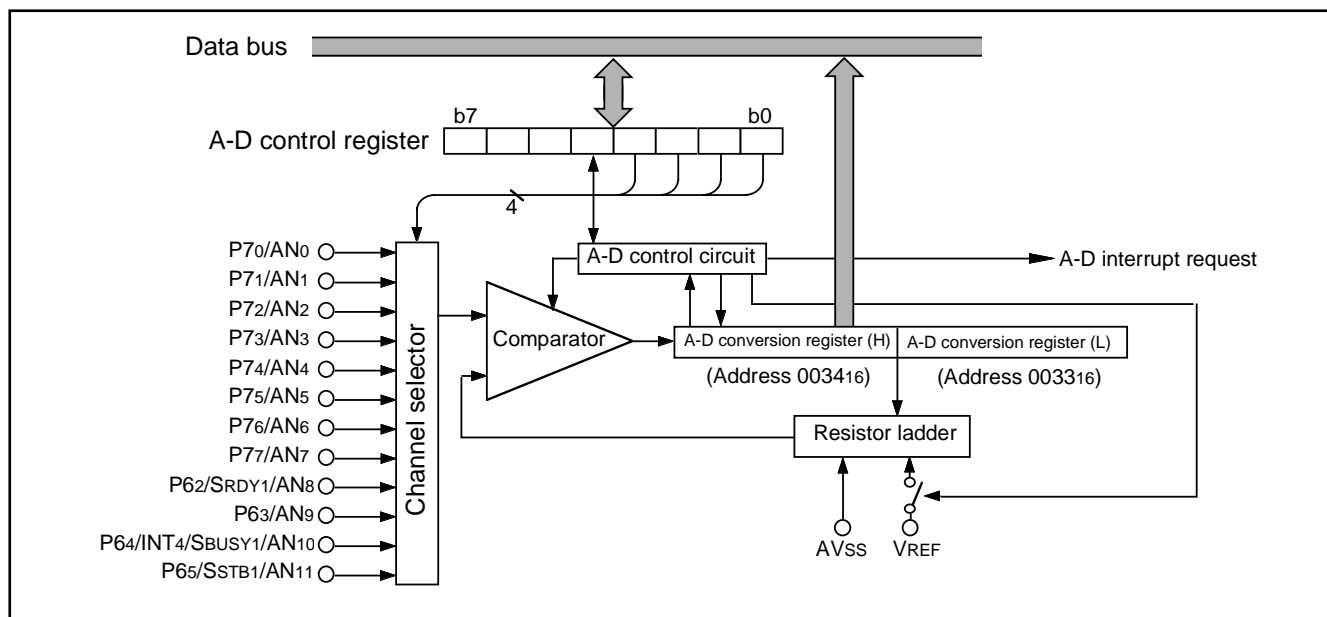

Fig. 55 Block diagram of A-D converter

**PULSE WIDTH MODULATION (PWM)**

The 38B4 group has a PWM function with a 14-bit resolution. When the oscillation frequency  $X_{IN}$  is 4 MHz, the minimum resolution bit width is 250 ns and the cycle period is 4096  $\mu$ s. The PWM timing generator supplies a PWM control signal based on a signal that is the frequency of the  $X_{IN}$  clock.

The explanation in the rest assumes  $X_{IN} = 4$  MHz.

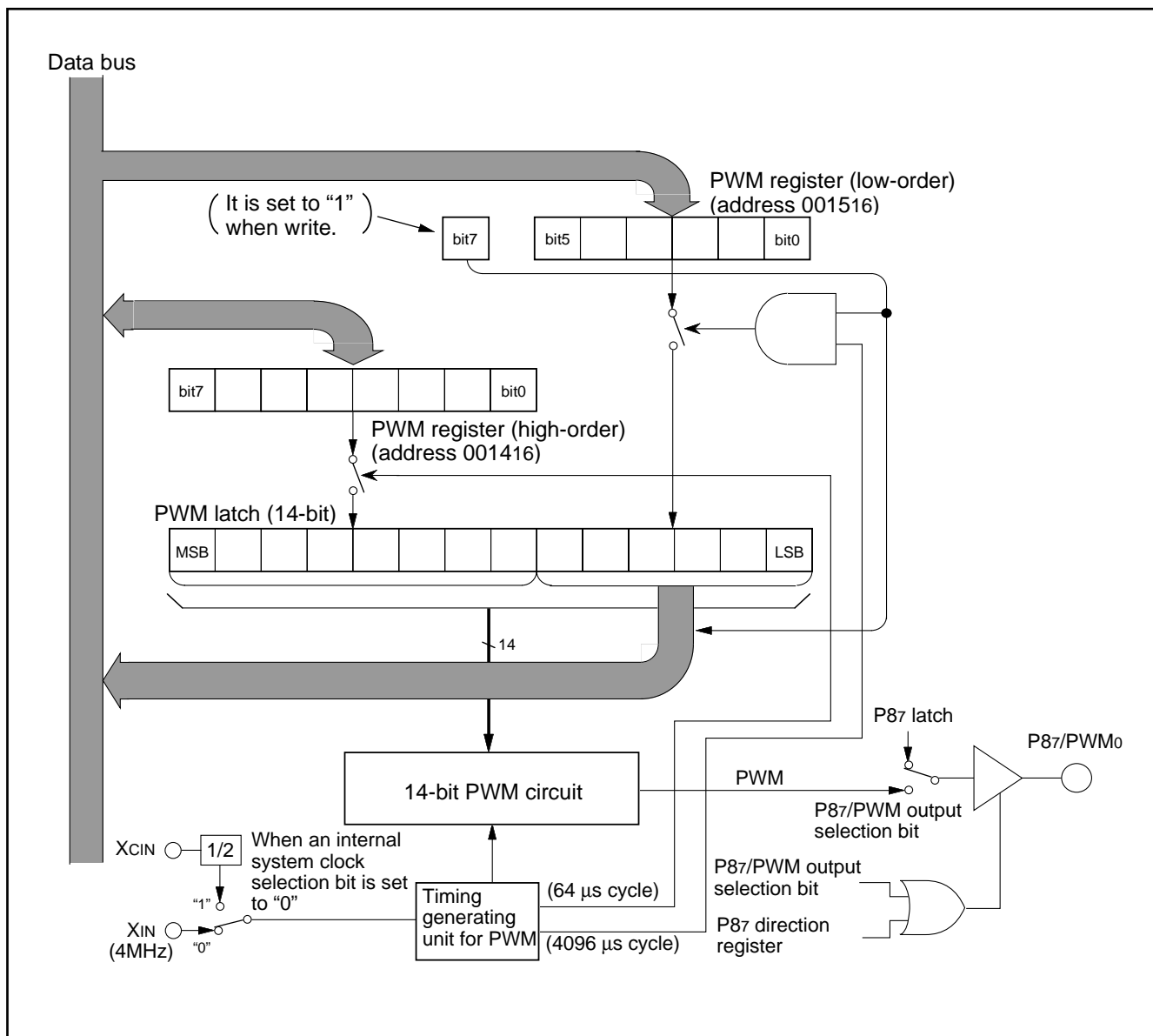

Fig. 56 PWM block diagram

**Data Setup**

The PWM output pin also function as port P87. Set port P87 to be the PWM output pin by setting bit 0 of the PWM control register (address 0026<sub>16</sub>) to "1". The high-order 8 bits of output data are set in the high-order PWM register PWMH (address 0014<sub>16</sub>) and the low-order 6 bits are set in the low-order PWM register PWML (address 0015<sub>16</sub>).

**PWM Operation**

The timing of the 14-bit PWM function is shown in Figure 57. The 14-bit PWM data is divided into the low-order 6 bits and the high-order 8 bits in the PWM latch.

The high-order 8 bits of data determine how long an "H" level signal is output during each sub-period. There are 64 sub-periods in each period, and each sub-period t is 256 X τ (= 64 μs) long. The signal's "H" has a length equal to N times τ, and its minimum resolution = 250 ns.

The last bit of the sub-period becomes the ADD bit which is specified either "H" or "L", by the contents of PWML. As shown in Table 10, the ADD bit is decided either "H" or "L".

That is, only in the sub-period t<sub>m</sub> shown in Table 10 in the PWM cycle period T = 64t, the "H" duration is lengthened during the minimum resolution width τ period in comparison with the other period. For example, if the high-order eight bits of the 14-bit data are "03<sub>16</sub>" and the low-order six bits are "05<sub>16</sub>", the length of the "H" level output in sub-periods t<sub>8</sub>, t<sub>24</sub>, t<sub>32</sub>, t<sub>40</sub> and t<sub>56</sub> is 4 τ, and its length 3 τ in all other sub-periods.

Time at the "H" level of each sub-period almost becomes equal because the time becomes length set in the high-order 8 bits or becomes the value plus τ, and this sub-period t (= 64 μs, approximate 15.6 kHz) becomes cycle period approximately.

**Transfer From Register To Latch**

Data written to the PWML register is transferred to the PWM latch once in each PWM period (every 4096 μs), and data written to the PWMH register is transferred to the PWM latch once in each sub-period (every 64 μs). When the PWML register is read, the contents of the latch are read. However, bit 7 of the PWML register indicates whether the transfer to the PWM latch is completed; the transfer is completed when bit 7 is "0".

**Table 10 Relationship between low-order 6-bit data and setting period of ADD bit**

Low-order 6-bit data	Sub-periods t <sub>m</sub> lengthened (m = 0 to 63)
0 0 0 0 0 0 <sup>LSB</sup>	None
0 0 0 0 0 1	m = 32
0 0 0 0 1 0	m = 16, 48
0 0 0 1 0 0	m = 8, 24, 40, 56
0 0 1 0 0 0	m = 4, 12, 20, 28, 36, 44, 52, 60
0 1 0 0 0 0	m = 2, 6, 10, 14, 18, 22, 26, 30, 34, 38, 42, 46, 50, 54, 58, 62
1 0 0 0 0 0	m = 1, 3, 5, 7, ..... 57, 59, 61, 63

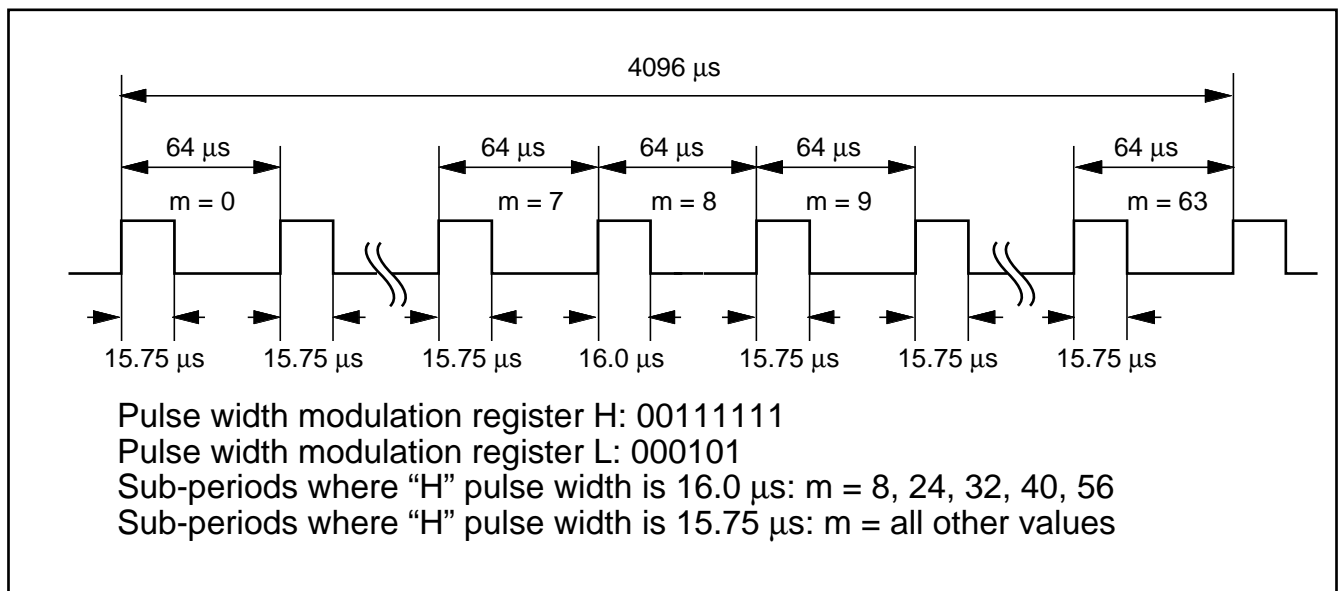

Fig. 57 PWM timing

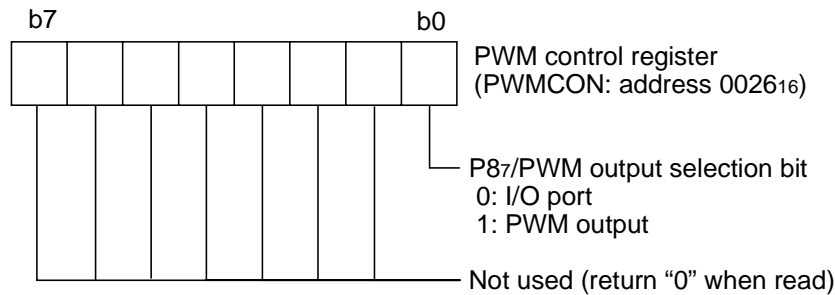

Fig. 58 Structure of PWM control register

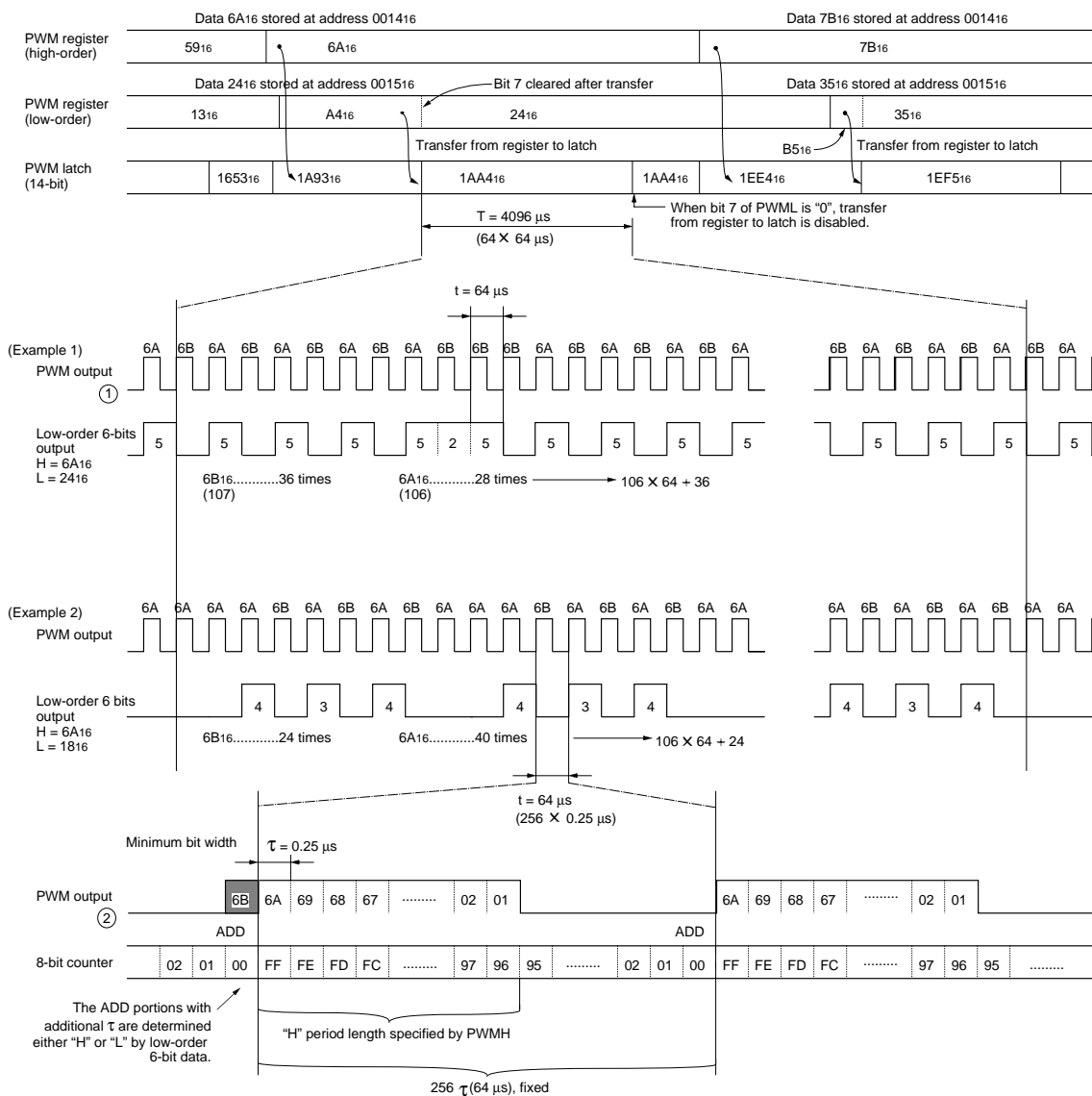

Fig. 59 14-bit PWM timing

**INTERRUPT INTERVAL DETERMINATION FUNCTION**

The 38B4 group has an interrupt interval determination circuit. This interrupt interval determination circuit has an 8-bit binary up counter. Using this counter, it determines a duration of time from the rising edge (falling edge) of an input signal pulse on the P47/INT2 pin to the rising edge (falling edge) of the signal pulse that is input next. How to determine the interrupt interval is described below.

1. Enable the INT2 interrupt by setting bit 2 of the interrupt control register 1 (address 003E16). Select the rising interval or falling interval by setting bit 2 of the interrupt edge selection register (address 003A16).
2. Set bit 0 of the interrupt interval determination control register (address 003116) to "1" (interrupt interval determination operating).
3. Select the sampling clock of 8-bit binary up counter by setting bit 1 of the interrupt interval determination control register. When writing "0",  $f(X_{IN})/128$  is selected (the sampling interval: 32  $\mu$ s at  $f(X_{IN}) = 4.19$  MHz); when "1",  $f(X_{IN})/256$  is selected (the sampling interval: 64  $\mu$ s at  $f(X_{IN}) = 4.19$  MHz).
4. When the signal of polarity which is set on the INT2 pin (rising or falling edge) is input, the 8-bit binary up counter starts counting up of the selected counter sampling clock.
5. When the signal of polarity above 4 is input again, the value of the 8-bit binary up counter is transferred to the interrupt interval determination register (address 003016), and the remote control interrupt request occurs. Immediately after that, the 8-bit binary up counter continues to count up again from "0016".
6. When count value reaches "FF16", the 8-bit binary up counter stops counting up. Then, simultaneously when the next counter sampling clock is input, the counter sets value "FF16" to the interrupt interval determination register to generate the counter overflow interrupt request.

**Noise Filter**

The P47/INT2 pin builds in the noise filter.

The noise filter operation is described below.

1. Select the sampling clock of the input signal with bits 2 and 3 of the interrupt interval determination control register. When not using the noise filter, set "00".
2. The P47/INT2 input signal is sampled in synchronization with the selected clock. When sampling the same level signal in a series of three sampling, the signal is recognized as the interrupt signal, and the interrupt request occurs.

When setting bit 4 of interrupt interval determination control register to "1", the interrupt request can occur at both rising and falling edges.

When using the noise filter, set the minimum pulse width of the INT2 input signal to 3 cycles or more of the sample clock.

**Note:** In the low-speed mode (CM7 = 1), the interrupt interval determination function cannot operate.

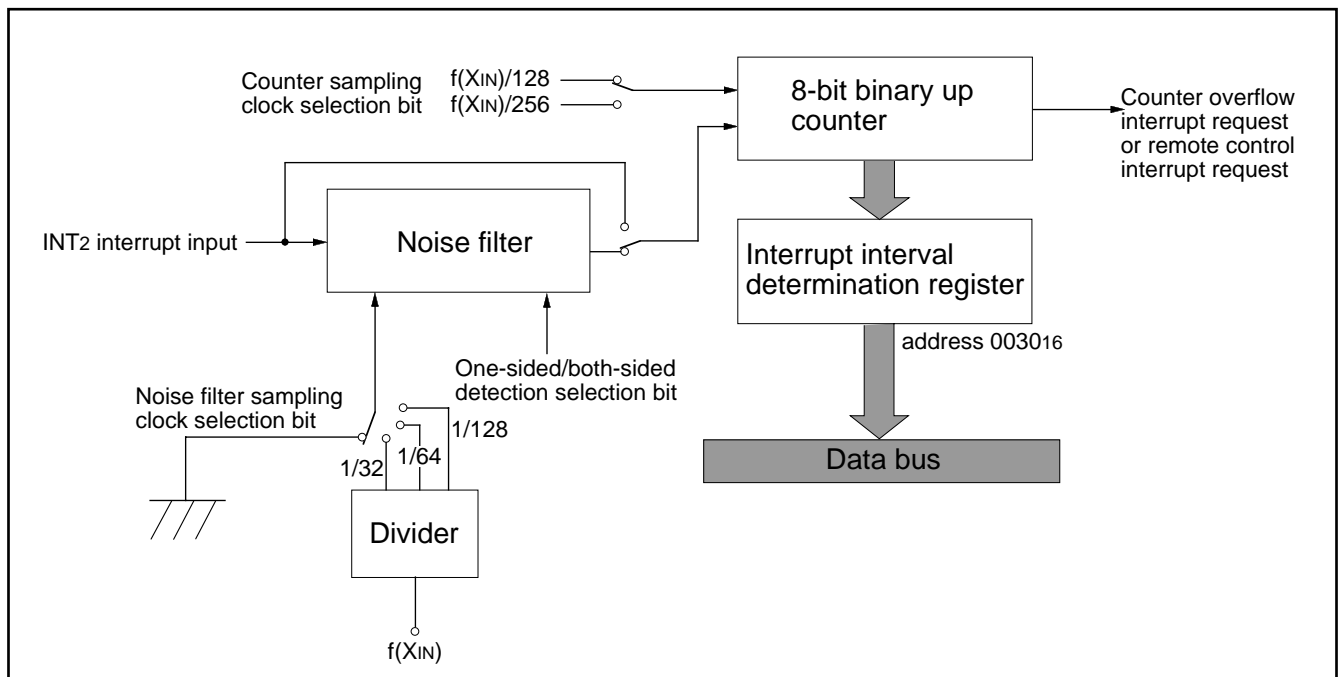

Fig. 60 Interrupt interval determination circuit block diagram

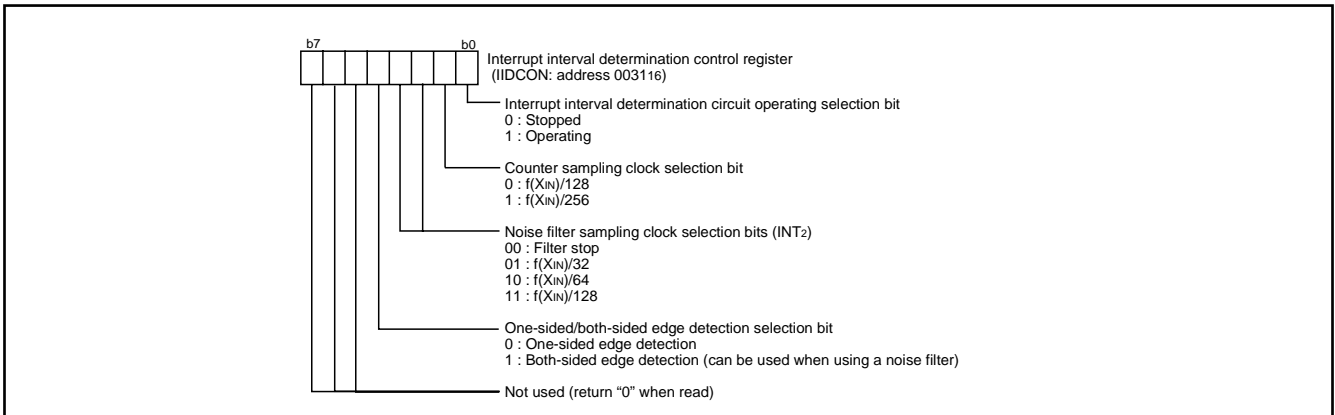

Fig. 61 Structure of interrupt interval determination control register

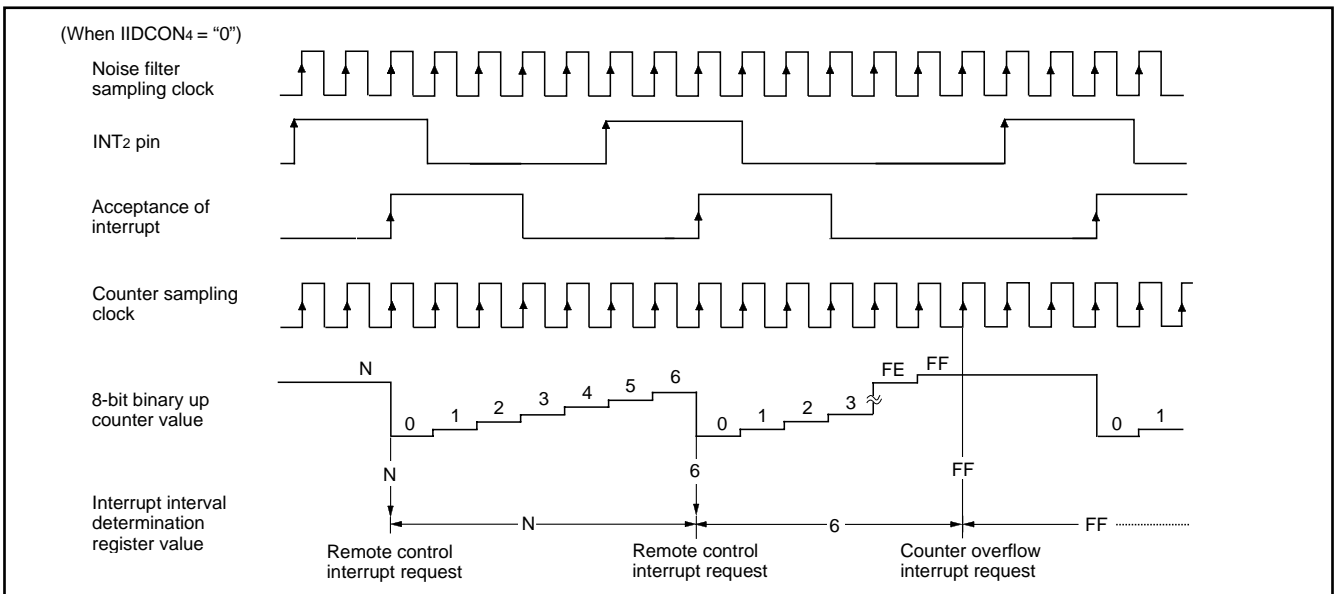

Fig. 62 Interrupt interval determination operation example (at rising edge active)

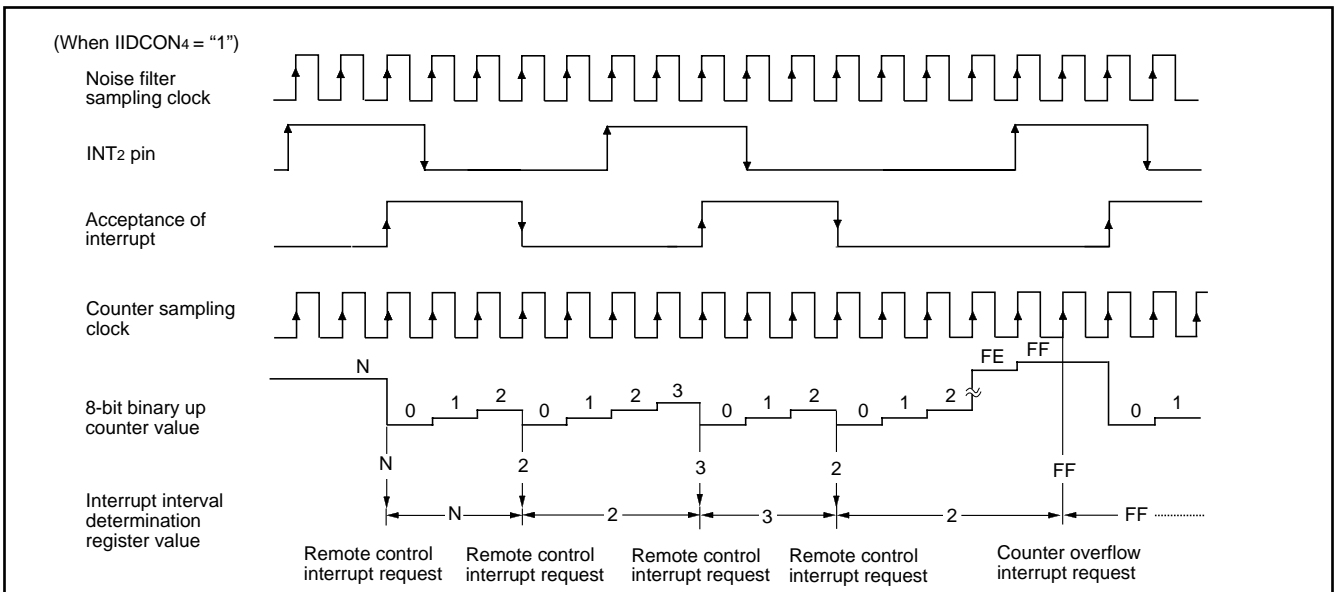

Fig. 63 Interrupt interval determination operation example (at both-sided edge active)



**WATCHDOG TIMER**

The watchdog timer gives a mean of returning to the reset status when a program cannot run on a normal loop (for example, because of a software runaway). The watchdog timer consists of an 8-bit watchdog timer L and a 12-bit watchdog timer H.

**Standard Operation Of Watchdog Timer**

When any data is not written into the watchdog timer control register (address 002B<sub>16</sub>) after resetting, the watchdog timer is in the stop state. The watchdog timer starts to count down by writing an optional value into the watchdog timer control register (address 002B<sub>16</sub>) and an internal reset occurs at an underflow of the watchdog timer H. Accordingly, programming is usually performed so that writing to the watchdog timer control register (address 002B<sub>16</sub>) may be started before an underflow. When the watchdog timer control register (address 002B<sub>16</sub>) is read, the values of the high-order 6 bits of the watchdog timer H, STP instruction disable bit, and watchdog timer H count source selection bit are read.

**●Initial value of watchdog timer**

At reset or writing to the watchdog timer control register (address 002B<sub>16</sub>), a watchdog timer H is set to "FFF<sub>16</sub>" and a watchdog timer L to "FF<sub>16</sub>".

**●Watchdog timer H count source selection bit operation**

Bit 7 of the watchdog timer control register (address 002B<sub>16</sub>) permits selecting a watchdog timer H count source. When this bit is set to

"0", the underflow signal of watchdog timer L becomes the count source. The detection time is set then to  $f(X_{IN}) = 2.1 \text{ s}$  at 4 MHz frequency and  $f(X_{CIN}) = 512 \text{ s}$  at 32 kHz frequency.

When this bit is set to "1", the count source becomes the signal divided by 8 for  $f(X_{IN})$  (or divided by 16 for  $f(X_{CIN})$ ). The detection time in this case is set to  $f(X_{IN}) = 8.2 \text{ ms}$  at 4 MHz frequency and  $f(X_{CIN}) = 2 \text{ s}$  at 32 KHz frequency. This bit is cleared to "0" after resetting.

**●Operation of STP instruction disable bit**

Bit 6 of the watchdog timer control register (address 002B<sub>16</sub>) permits disabling the STP instruction when the watchdog timer is in operation.

When this bit is "0", the STP instruction is enabled.

When this bit is "1", the STP instruction is disabled.

Once the STP instruction is executed, an internal resetting occurs.

When this bit is set to "1", it cannot be rewritten to "0" by program. This bit is cleared to "0" after resetting.

**■ Note**

When releasing the stop mode, the watchdog timer performs its count operation even in the stop release waiting time. Be careful not to cause the watchdog timer H to underflow in the stop release waiting time, for example, by writing data in the watchdog timer control register (address 002B<sub>16</sub>) before executing the STP instruction.

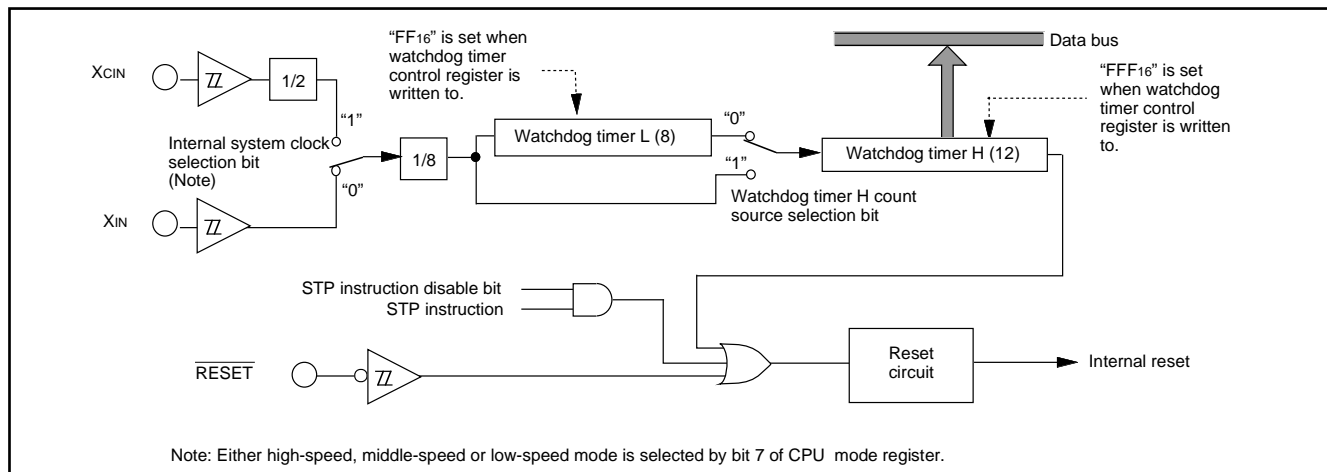

Fig. 64 Block diagram of watchdog timer

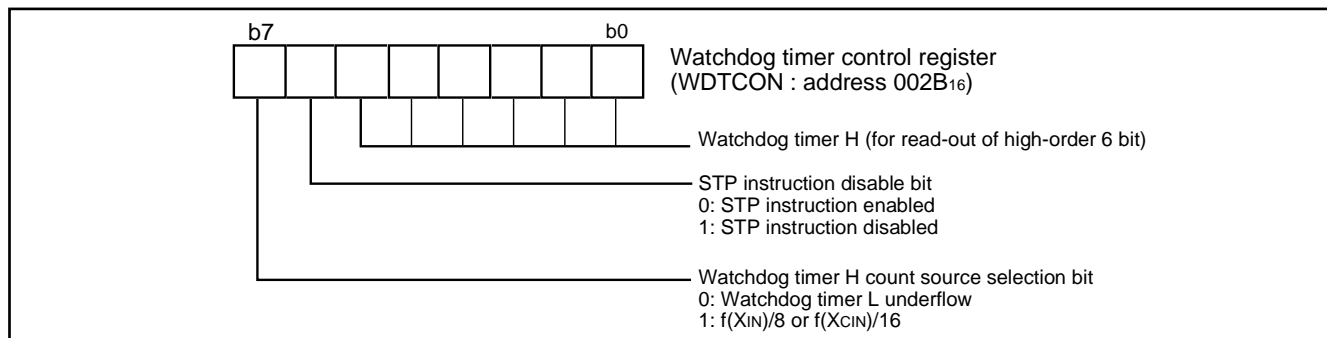

Fig. 65 Structure of watchdog timer control register

**BUZZER OUTPUT CIRCUIT**

The 38B4 group has a buzzer output circuit. One of 1 kHz, 2 kHz and 4 kHz (at  $X_{IN} = 4.19$  MHz) frequencies can be selected by the buzzer output control register (address 0EFD<sub>16</sub>). Either P4<sub>3</sub>/BUZ<sub>01</sub> or P2<sub>0</sub>/BUZ<sub>02</sub>/FLD<sub>0</sub> can be selected as a buzzer output port by the output port selection bits (b2 and b3 of address 0EFD<sub>16</sub>).

The buzzer output is controlled by the buzzer output ON/OFF bit (b4).

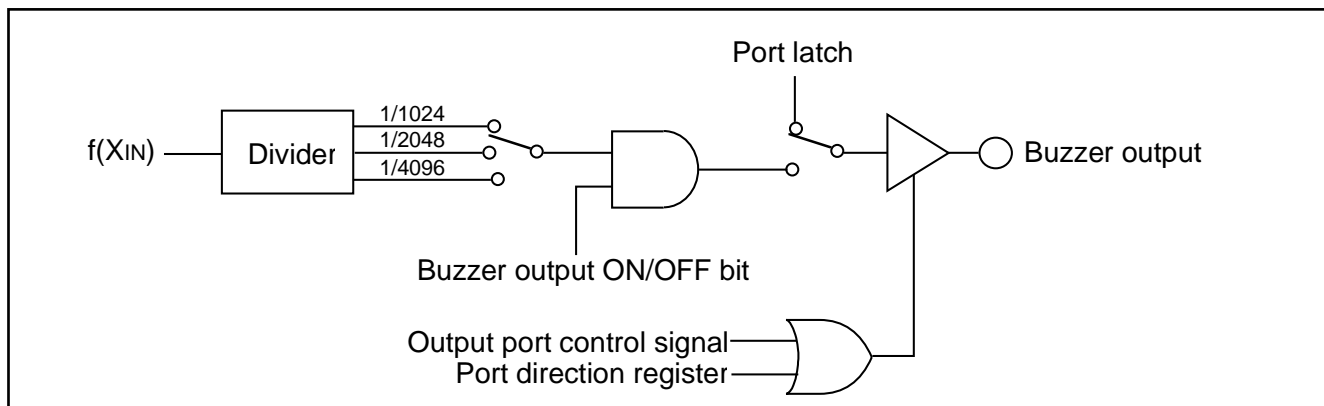

Fig. 66 Block diagram of buzzer output circuit

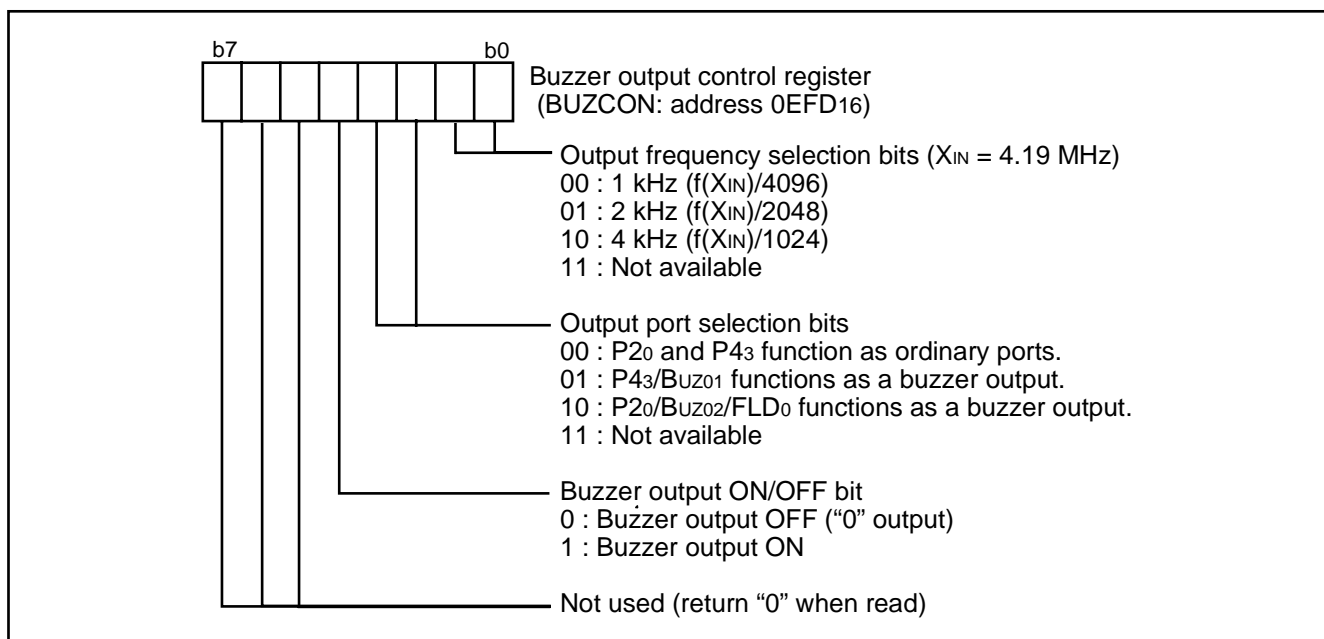

Fig. 67 Structure of buzzer output control register

**RESET CIRCUIT**

To reset the microcomputer, RESET pin should be held at an "L" level for 2 μs or more. Then the RESET pin is returned to an "H" level (the power source voltage should be between 2.7 V and 5.5 V, and the oscillation should be stable), reset is released. After the reset is completed, the program starts from the address contained in address FFFD<sub>16</sub> (high-order byte) and address FFFC<sub>16</sub> (low-order byte). Make sure that the reset input voltage is less than 0.5 V for V<sub>cc</sub> of 2.7 V (switching to the high-speed mode, a power source voltage must be between 4.0 V and 5.5 V).

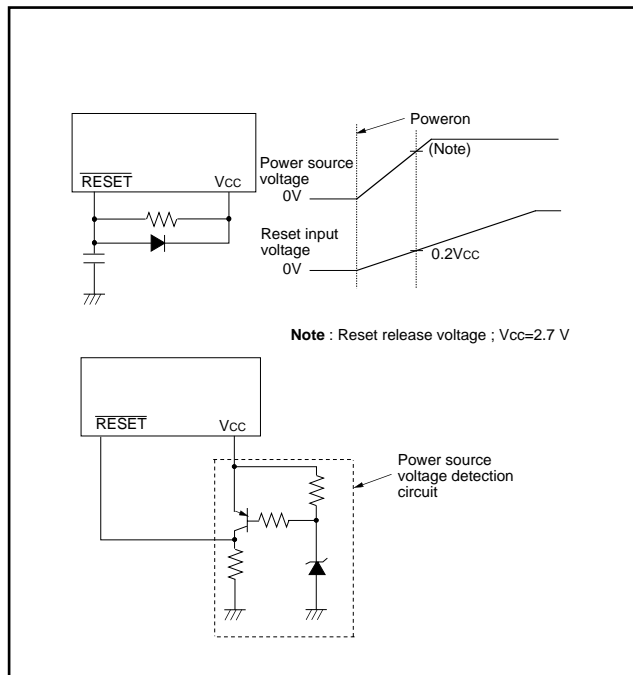

Fig. 68 Reset circuit example

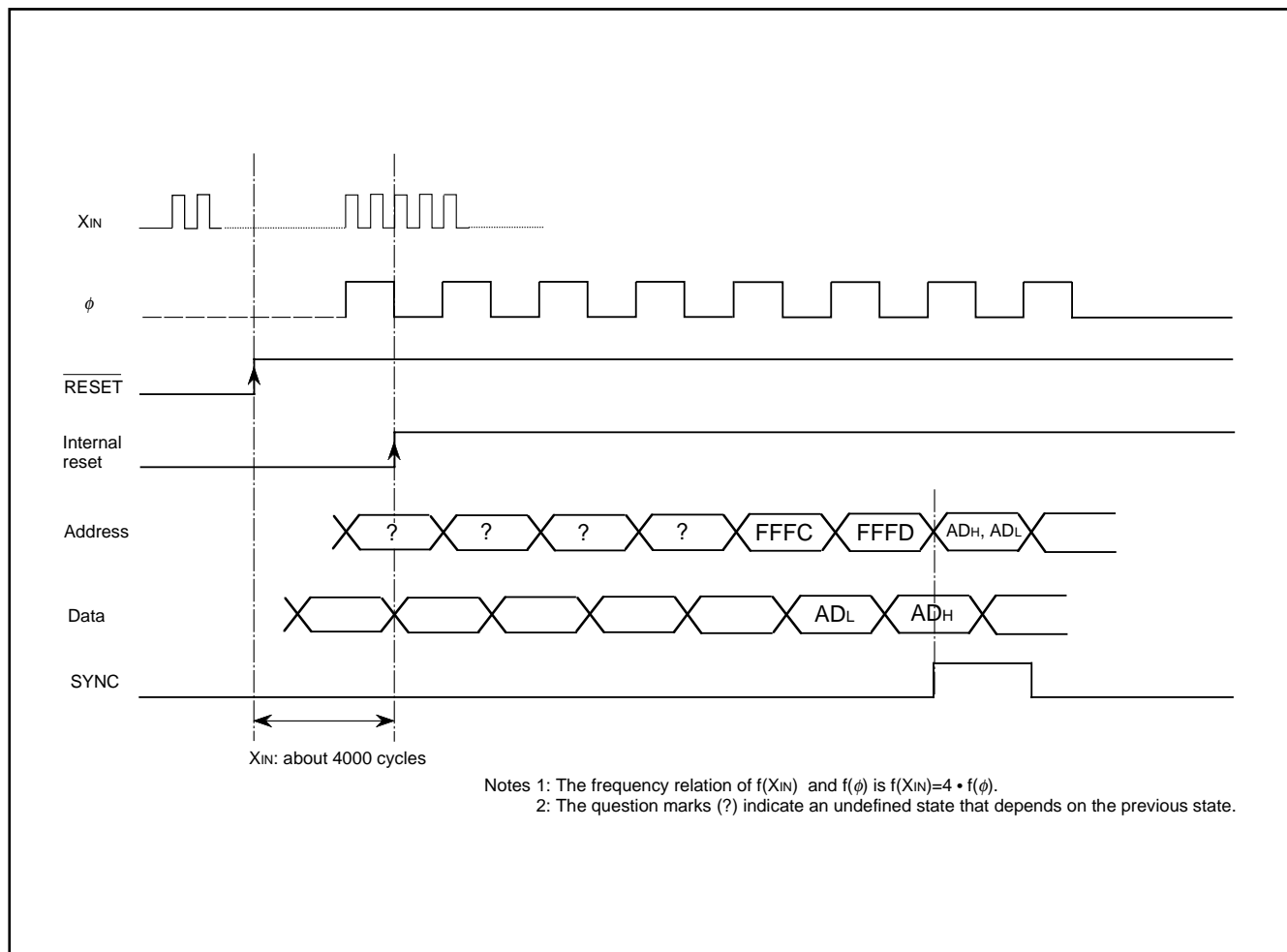

Fig. 69 Reset sequence

	Address	Register contents		Address	Register contents
(1) Port P0	0000 <sub>16</sub>	00 <sub>16</sub>	(33) Timer 34 mode register	0029 <sub>16</sub>	00 <sub>16</sub>
(2) Port P0 direction register	0001 <sub>16</sub>	00 <sub>16</sub>	(34) Timer 56 mode register	002A <sub>16</sub>	00 <sub>16</sub>
(3) Port P1	0002 <sub>16</sub>	00 <sub>16</sub>	(35) Watchdog timer control register	002B <sub>16</sub>	3F <sub>16</sub>
(4) Port P2	0004 <sub>16</sub>	00 <sub>16</sub>	(36) Timer X (low-order)	002C <sub>16</sub>	FF <sub>16</sub>
(5) Port P2 direction register	0005 <sub>16</sub>	00 <sub>16</sub>	(37) Timer X (high-order)	002D <sub>16</sub>	FF <sub>16</sub>
(6) Port P3	0006 <sub>16</sub>	00 <sub>16</sub>	(38) Timer X mode register 1	002E <sub>16</sub>	00 <sub>16</sub>
(7) Port P4	0008 <sub>16</sub>	00 <sub>16</sub>	(39) Timer X mode register 2	002F <sub>16</sub>	00 <sub>16</sub>
(8) Port P4 direction register	0009 <sub>16</sub>	00 <sub>16</sub>	(40) Interrupt interval determination control register	0031 <sub>16</sub>	00 <sub>16</sub>
(9) Port P5	000A <sub>16</sub>	00 <sub>16</sub>	(41) A-D control register	0032 <sub>16</sub>	10 <sub>16</sub>
(10) Port P5 direction register	000B <sub>16</sub>	00 <sub>16</sub>	(42) Interrupt source switch register	0039 <sub>16</sub>	00 <sub>16</sub>
(11) Port P6	000C <sub>16</sub>	00 <sub>16</sub>	(43) Interrupt edge selection register	003A <sub>16</sub>	00 <sub>16</sub>
(12) Port P6 direction register	000D <sub>16</sub>	00 <sub>16</sub>	(44) CPU mode register	003B <sub>16</sub>	0100101000
(13) Port P7	000E <sub>16</sub>	00 <sub>16</sub>	(45) Interrupt request register 1	003C <sub>16</sub>	00 <sub>16</sub>
(14) Port P7 direction register	000F <sub>16</sub>	00 <sub>16</sub>	(46) Interrupt request register 2	003D <sub>16</sub>	00 <sub>16</sub>
(15) Port P8	0010 <sub>16</sub>	00 <sub>16</sub>	(47) Interrupt control register 1	003E <sub>16</sub>	00 <sub>16</sub>
(16) Port P8 direction register	0011 <sub>16</sub>	00 <sub>16</sub>	(48) Interrupt control register 2	003F <sub>16</sub>	00 <sub>16</sub>
(17) Port P9	0012 <sub>16</sub>	00 <sub>16</sub>	(49) Pull-up control register 1	0EF0 <sub>16</sub>	00 <sub>16</sub>
(18) Port P9 direction register	0013 <sub>16</sub>	00 <sub>16</sub>	(50) Pull-up control register 2	0EF1 <sub>16</sub>	00 <sub>16</sub>
(19) UART control register	0017 <sub>16</sub>	80 <sub>16</sub>	(51) FLDC mode register	0EF4 <sub>16</sub>	00 <sub>16</sub>
(20) Serial I/O1 control register 1	0019 <sub>16</sub>	00 <sub>16</sub>	(52) Tdisp time set register	0EF5 <sub>16</sub>	00 <sub>16</sub>
(21) Serial I/O1 control register 2	001A <sub>16</sub>	00 <sub>16</sub>	(53) Toff1 time set register	0EF6 <sub>16</sub>	FF <sub>16</sub>
(22) Serial I/O1 control register 3	001C <sub>16</sub>	00 <sub>16</sub>	(54) Toff2 time set register	0EF7 <sub>16</sub>	FF <sub>16</sub>
(23) Serial I/O2 control register	001D <sub>16</sub>	00 <sub>16</sub>	(55) Port P0FLD/port switch register	0EF9 <sub>16</sub>	00 <sub>16</sub>
(24) Serial I/O2 status register	001E <sub>16</sub>	80 <sub>16</sub>	(56) Port P2FLD/port switch register	0EFA <sub>16</sub>	00 <sub>16</sub>
(25) Timer 1	0020 <sub>16</sub>	FF <sub>16</sub>	(57) Port P8FLD/port switch register	0EFB <sub>16</sub>	00 <sub>16</sub>
(26) Timer 2	0021 <sub>16</sub>	01 <sub>16</sub>	(58) Port P8FLD output control register	0EFC <sub>16</sub>	00 <sub>16</sub>
(27) Timer 3	0022 <sub>16</sub>	FF <sub>16</sub>	(59) Buzzer output control register	0EFD <sub>16</sub>	00 <sub>16</sub>
(28) Timer 4	0023 <sub>16</sub>	FF <sub>16</sub>	(60) Processor status register	(PS)	XXXXX1XX
(29) Timer 5	0024 <sub>16</sub>	FF <sub>16</sub>	(61) Program counter	(PCH)	FFF <sub>16</sub> contents
(30) Timer 6	0025 <sub>16</sub>	FF <sub>16</sub>		(PCL)	FFF <sub>16</sub> contents
(31) PWM control register	0026 <sub>16</sub>	00 <sub>16</sub>			
(32) Timer 12 mode register	0028 <sub>16</sub>	00 <sub>16</sub>			

X: Not fixed  
 Since the initial values for other than above mentioned registers and RAM contents are indefinite at reset, they must be set.

Fig. 70 Internal status at reset

**CLOCK GENERATING CIRCUIT**

The 38B4 group has two built-in oscillation circuits. An oscillation circuit can be formed by connecting a resonator between X<sub>IN</sub> and X<sub>OUT</sub> (X<sub>CIN</sub> and X<sub>COU</sub>T). Use the circuit constants in accordance with the resonator manufacturer's recommended values. No external resistor is needed between X<sub>IN</sub> and X<sub>OUT</sub> since a feedback resistor exists on-chip. However, an external feedback resistor is needed between X<sub>CIN</sub> and X<sub>COU</sub>T.

Immediately after power on, only the X<sub>IN</sub> oscillation circuit starts oscillating, and X<sub>CIN</sub> and X<sub>COU</sub>T pins function as I/O ports.

**Frequency Control**

**(1) Middle-speed mode**

The internal system clock is the frequency of X<sub>IN</sub> divided by 4. After reset, this mode is selected.

**(2) High-speed mode**

The internal system clock is the frequency of X<sub>IN</sub>.

**(3) Low-speed mode**

The internal system clock is the frequency of X<sub>CIN</sub> divided by 2.

**■Note**

If you switch the mode between middle/high-speed and low-speed, stabilize both X<sub>IN</sub> and X<sub>CIN</sub> oscillations. The sufficient time is required for the sub clock to stabilize, especially immediately after power on and at returning from stop mode. When switching the mode between middle/high-speed and low-speed, set the frequency on condition that  $f(X_{IN}) > 3f(X_{CIN})$ .

**(4) Low power consumption mode**

The low power consumption operation can be realized by stopping the main clock X<sub>IN</sub> in low-speed mode. To stop the main clock, set bit 5 of the CPU mode register to "1". When the main clock X<sub>IN</sub> is restarted (by setting the main clock stop bit to "0"), set enough time for oscillation to stabilize.

By clearing furthermore the X<sub>COU</sub>T drivability selection bit (b3) of CPU mode register to "0", low power consumption operation of less than 200 μA ( $f(X_{CIN}) = 32 \text{ kHz}$ ) can be realized by reducing the drivability between X<sub>CIN</sub> and X<sub>COU</sub>T. At reset or during STP instruction execution this bit is set to "1" and a strong drivability that has an easy oscillation start is set.

**Oscillation Control**

**(1) Stop mode**

If the STP instruction is executed, the internal system clock stops at an "H" level, and X<sub>IN</sub> and X<sub>CIN</sub> oscillators stop. Timer 1 is set to "FF<sub>16</sub>" and timer 2 is set to "01<sub>16</sub>".

Either X<sub>IN</sub> divided by 8 or X<sub>CIN</sub> divided by 16 is input to timer 1 as count source, and the output of timer 1 is connected to timer 2. The bits of the timer 12 mode register are cleared to "0". Set the interrupt enable bits of the timer 1 and timer 2 to disabled ("0") before executing the STP instruction. Oscillator restarts when an external interrupt is received or reset, but the internal system clock is not supplied to the CPU until timer 1 underflows. This allows time for the clock circuit oscillation to stabilize.

**(2) Wait mode**

If the WIT instruction is executed, the internal system clock stops at an "H" level. The states of X<sub>IN</sub> and X<sub>CIN</sub> are the same as the state before executing the WIT instruction. The internal system clock restarts at reset or when an interrupt is received. Since the oscillator does not stop, normal operation can be started immediately after the clock is restarted.

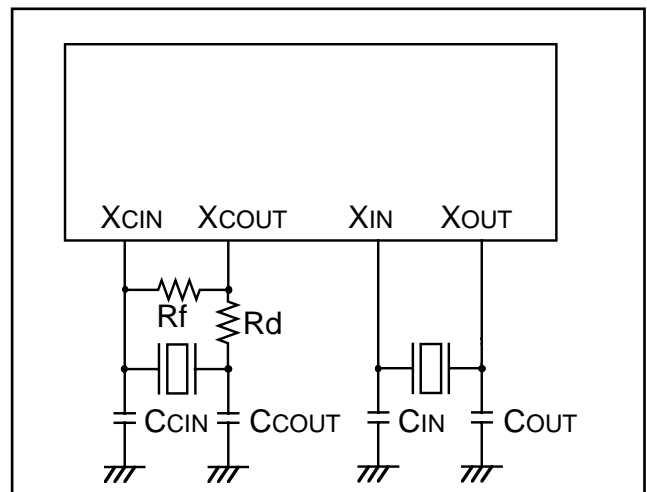

Fig. 71 Ceramic resonator circuit

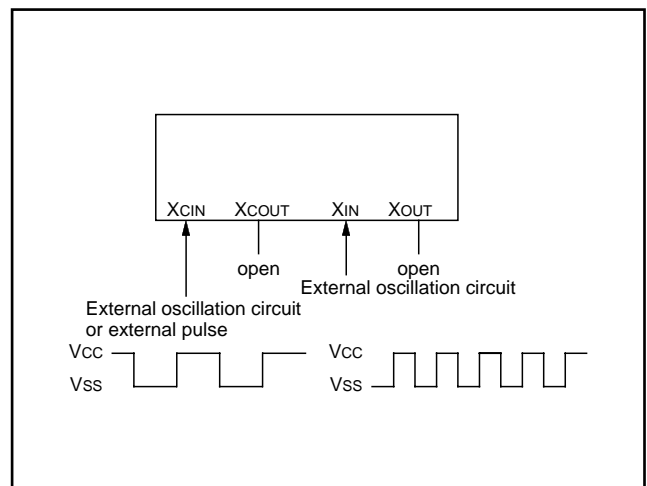

Fig. 72 External clock input circuit

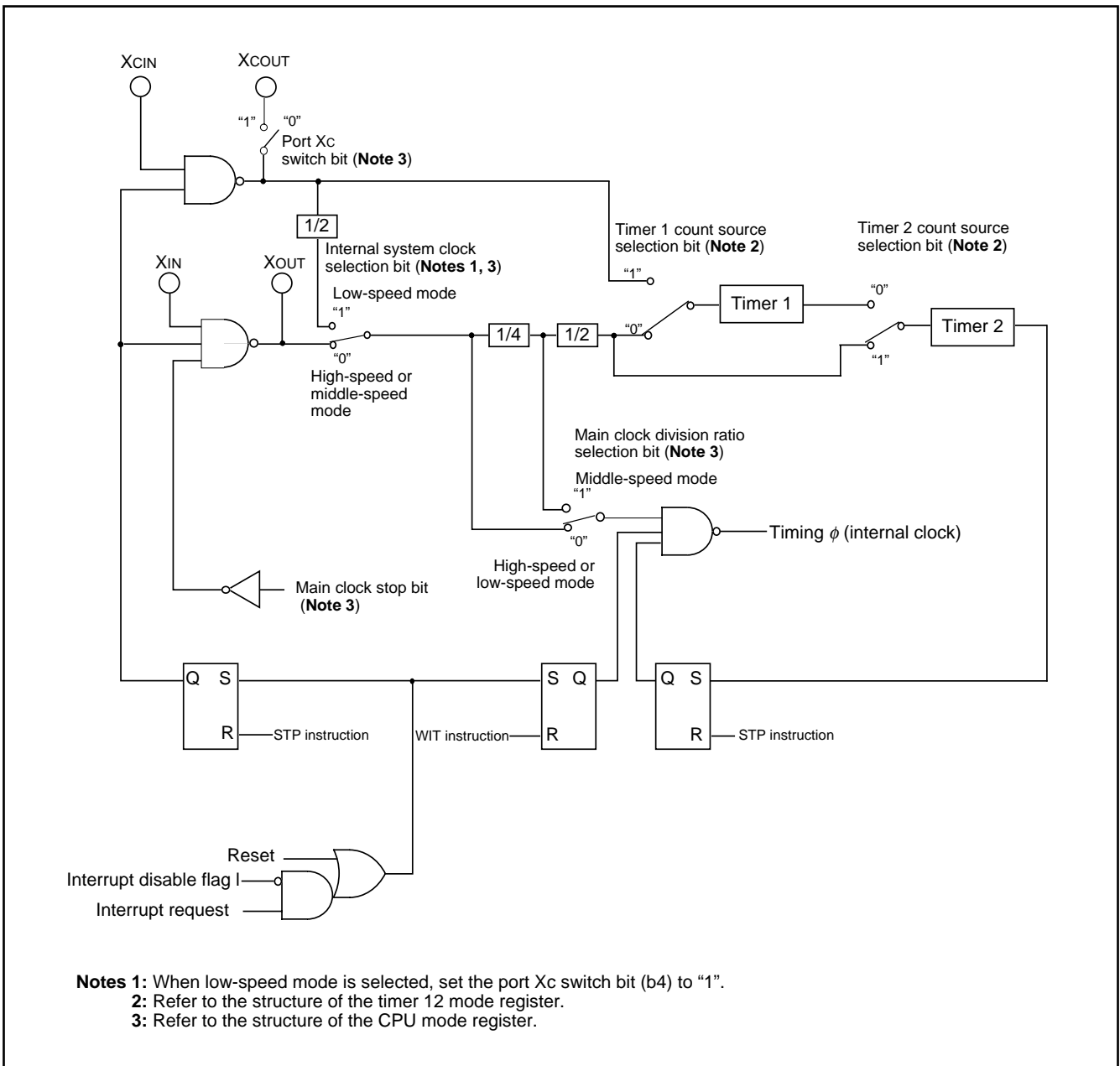
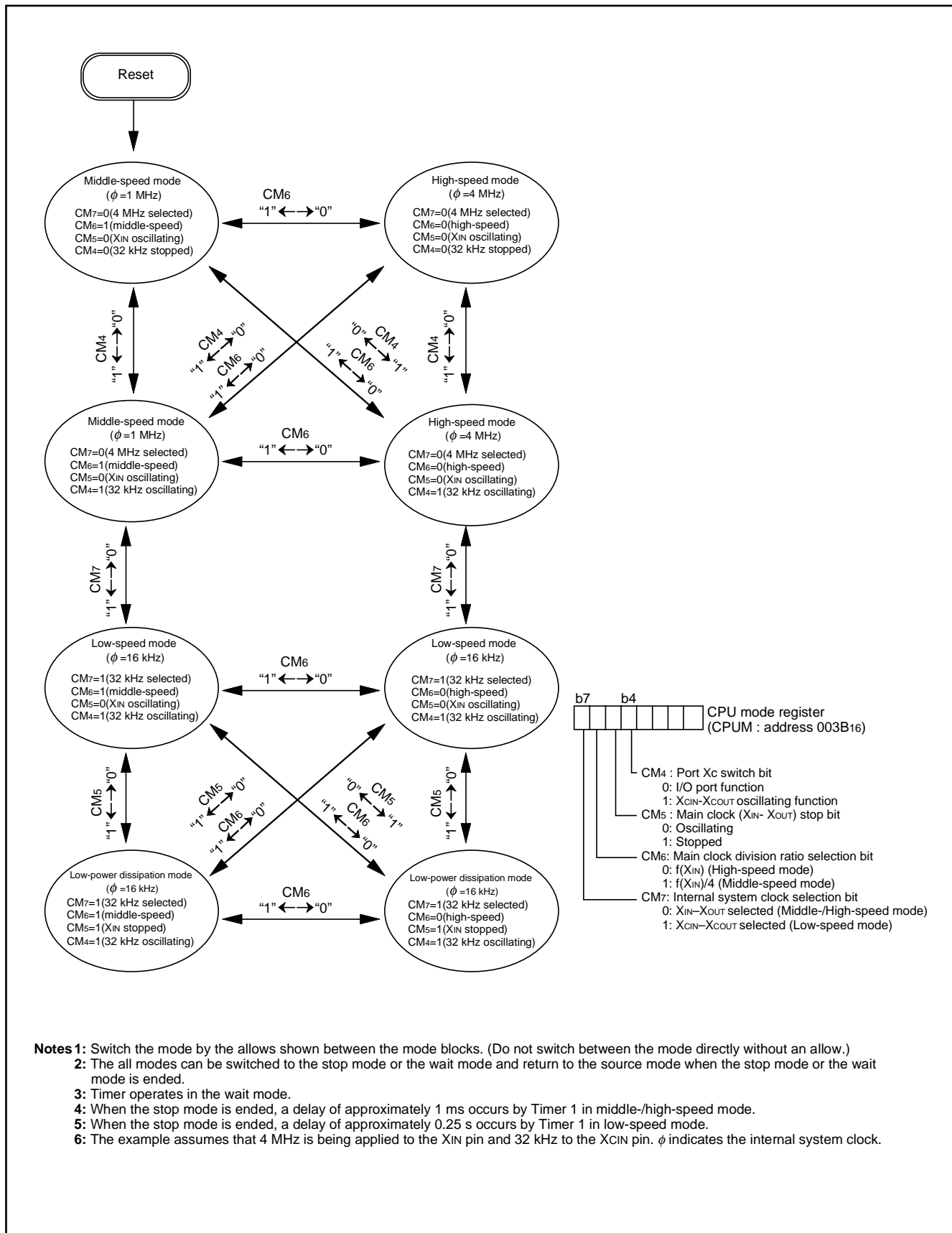

Fig. 73 Clock generating circuit block diagram



- Notes 1:** Switch the mode by the allows shown between the mode blocks. (Do not switch between the mode directly without an allow.)
- 2:** The all modes can be switched to the stop mode or the wait mode and return to the source mode when the stop mode or the wait mode is ended.
- 3:** Timer operates in the wait mode.
- 4:** When the stop mode is ended, a delay of approximately 1 ms occurs by Timer 1 in middle-/high-speed mode.
- 5:** When the stop mode is ended, a delay of approximately 0.25 s occurs by Timer 1 in low-speed mode.
- 6:** The example assumes that 4 MHz is being applied to the X<sub>IN</sub> pin and 32 kHz to the X<sub>CIN</sub> pin.  $\phi$  indicates the internal system clock.

Fig. 74 State transitions of system clock

## NOTES ON PROGRAMMING

### Processor Status Register

The contents of the processor status register (PS) after a reset are undefined, except for the interrupt disable flag (I) which is "1". After a reset, initialize flags which affect program execution. In particular, it is essential to initialize the index X mode (T) and the decimal mode (D) flags because of their effect on calculations.

### Interrupts

The contents of the interrupt request bits do not change immediately after they have been written. After writing to an interrupt request register, execute at least one instruction before performing a BBC or BBS instruction.

### Decimal Calculations

- To calculate in decimal notation, set the decimal mode flag (D) to "1", then execute an ADC or SBC instruction. Only the ADC and SBC instructions yield proper decimal results. After executing an ADC or SBC instruction, execute at least one instruction before executing a SEC, CLC, or CLD instruction.
- In decimal mode, the values of the negative (N), overflow (V), and zero (Z) flags are invalid.

### Timers

If a value  $n$  (between 0 and 255) is written to a timer latch, the frequency division ratio is  $1/(n+1)$ .

### Multiplication and Division Instructions

- The index X mode (T) and the decimal mode (D) flags do not affect the MUL and DIV instruction.
- The execution of these instructions does not change the contents of the processor status register.

### Ports

The contents of the port direction registers cannot be read. The following cannot be used:

- The data transfer instruction (LDA, etc.)
- The operation instruction when the index X mode flag (T) is "1"
- The addressing mode which uses the value of a direction register as an index
- The bit-test instruction (BBC or BBS, etc.) to a direction register
- The read-modify-write instructions (ROR, CLB, or SEB, etc.) to a direction register.

Use instructions such as LDM and STA, etc., to set the port direction registers.

### Serial I/O

- Using an external clock  
When using an external clock, input "H" to the external clock input pin and clear the serial I/O interrupt request bit before executing serial I/O transfer and serial I/O automatic transfer.
- Using an internal clock  
When using an internal clock, set the synchronous clock to the internal clock, then clear the serial I/O interrupt request bit before executing a serial I/O transfer and serial I/O automatic transfer.

### Automatic Transfer Serial I/O

When using the automatic transfer serial I/O mode of the serial I/O1, set an automatic transfer interval as the following. Otherwise the serial data might be incorrectly transmitted/received.

- Set an automatic transfer interval for each 1-byte data transfer as the following:
  - (1) Not using FLD controller  
Keep the interval for **5 cycles or more of internal system clock** from clock rising of the last bit of 1-byte data.
  - (2) Using FLD controller
    - (a) Not using gradation display  
Keep the interval for **12 cycles or more of internal system clock** from clock rising of the last bit of 1-byte data.
    - (b) Using gradation display  
Keep the interval for **18 cycles or more of internal system clock** from clock rising of the last bit of 1-byte data.

### A-D Converter

The comparator uses internal capacitors whose charge will be lost if the clock frequency is too low.

Therefore, make sure that  $f(X_{IN})$  is at least on 250 kHz during an A-D conversion.

Do not execute the STP or WIT instruction during an A-D conversion.

### Instruction Execution Time

The instruction execution time is obtained by multiplying the frequency of the internal system clock by the number of cycles needed to execute an instruction.

The number of cycles required to execute an instruction is shown in the list of machine instructions.

The frequency of the internal system clock is the same of the  $X_{IN}$  frequency in high-speed mode.

### At STP Instruction Release

At the STP instruction release, all bits of the timer 12 mode register are cleared.

The X<sub>COUT</sub> drivability selection bit (the CPU mode register) is set to "1" (high drive) in order to start oscillating.

### DATA REQUIRED FOR MASK ORDERS

The following are necessary when ordering a mask ROM production:

- (1) Mask ROM Order Confirmation Form
- (2) Mark Specification Form
- (3) Data to be written to ROM, in EPROM form (three identical copies)



**MASK OPTION OF PULL-DOWN RESISTOR**  
(object product: M38B4XXMH-XXXXFP)

Whether built-in pull-down resistors are connected or not to high-breakdown voltage ports P20 to P27 and P80 to P83 can be specified in ordering mask ROM. The option type can be specified from among 8 types; A to G, P as shown Table 11.

**Table 11 Mask option type of pull-down resistor**

Option type	Connective port of pull-down resistor (connected at "1" writing)												Restriction
	P20	P21	P22	P23	P24	P25	P26	P27	P80	P81	P82	P83	
A (\$41)													(Note 4)
B (\$42)							1	1					
C (\$43)				1	1	1	1	1					
D (\$44)		1	1	1	1	1	1	1					
E (\$45)	1	1	1	1	1	1	1	1					
F (\$46)	1	1	1	1	1	1	1	1	1	1			
G (\$47)	1	1	1	1	1	1	1	1	1	1	1	1	
P (\$50)	1	1	1	1	1	1	1	1	1	1	1	1	

- Notes 1:** The electrical characteristics of high-breakdown voltage ports P20 to P27 and P80 to P83's built-in pull-down resistors are the same as that of high-breakdown voltage ports P00 to P07.
- 2:** The absolute maximum ratings of power dissipation may be exceeded owing to the number of built-in pull-down resistor. After calculating the power dissipation, specify the option type.
- 3:** One time PROM version and EPROM version cannot be specified whether built-in pull-down resistors are connected or not likewise option type A.
- 4:** INT3 function and CNTR1 function cannot be used in the option type P.

**Power Dissipation Calculating Method**

- Fixed number depending on microcomputer's standard
  - V<sub>OH</sub> output fall voltage of high-breakdown port 2 V (max.); | Current value | = at 18 mA
  - Resistor value 43 V / 900 μA = 48 kΩ (min.)
  - Power dissipation of internal circuit (CPU, ROM, RAM etc.) = 5 V × 15 mA = 75 mW

- Fixed number depending on use condition
  - Apply voltage to V<sub>EE</sub> pin: V<sub>cc</sub> – 45 V
  - Timing number a; digit number b; segment number c
  - Ratio of T<sub>off</sub> time corresponding T<sub>disp</sub> time: 1/16
  - Turn ON segment number during repeat cycle: d
  - All segment number during repeat cycle: e (= a × c)
  - Total number of built-in resistor: for digit; f, for segment; g
  - Digit pin current value h (mA)
  - Segment pin current value i (mA)

- (1) Digit pin power dissipation  
{h × b × (1–T<sub>off</sub>/T<sub>disp</sub>) × voltage} / a
- (2) Segment pin power dissipation  
{i × d × (1–T<sub>off</sub>/T<sub>disp</sub>) × voltage} / a
- (3) Pull-down resistor power dissipation (digit)  
{power dissipation per 1 digit × (b × f / b) × (1–T<sub>off</sub>/T<sub>disp</sub>)} / a
- (4) Pull-down resistor power dissipation (segment)  
{power dissipation per 1 segment × (d × g / c) × (1–T<sub>off</sub>/T<sub>disp</sub>)} / a
- (5) Internal circuit power dissipation (CPU, ROM, RAM etc.) = 75 mW

(1) + (2) + (3) + (4) + (5) = X mW

**Power Dissipation Calculating Example 1**

- Fixed number depending on microcomputer's standard
  - V<sub>OH</sub> output fall voltage of high-breakdown port 2 V (max.); | Current value | = at 18 mA
  - Resistor value 43 V / 900 μA = 48 kΩ (min.)
  - Power dissipation of internal circuit (CPU, ROM, RAM etc.) = 5 V × 15 mA = 75 mW
- Fixed number depending on use condition
  - Apply voltage to V<sub>EE</sub> pin: V<sub>cc</sub> – 45 V
  - Timing number 17; digit number 16; segment number 20
  - Ratio of T<sub>off</sub> time corresponding T<sub>disp</sub> time: 1/16
  - Turn ON segment number during repeat cycle: 31
  - All segment number during repeat cycle: 340 (= 17 × 20)
  - Total number of built-in resistor: for digit; 16, for segment; 20
  - Digit pin current value: 18 (mA)
  - Segment pin current value: 3 (mA)

- (1) Digit pin power dissipation  
{18 × 16 × (1–1/16) × 2} / 17 = 31.77 mW
- (2) Segment pin power dissipation  
{3 × 31 × (1–1/16) × 2} / 17 = 10.26 mW
- (3) Pull-down resistor power dissipation (digit)  
(45 – 2)<sup>2</sup> / 48 × (16 × 16/16) × (1 – 1/16) / 17 = 33.99 mW
- (4) Pull-down resistor power dissipation (segment)  
(45 – 2)<sup>2</sup> / 48 × (31 × 20/20) × (1 – 1/16) / 17 = 65.86 mW
- (5) Internal circuit power dissipation (CPU, ROM, RAM etc.) = 75 mW

(1) + (2) + (3) + (4) + (5) = 217 mW

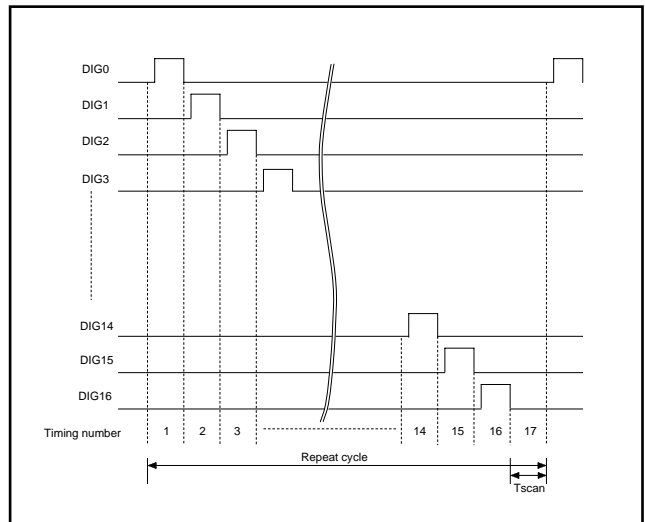

Fig. 75 Digit timing waveform (1)

**Power Dissipation Calculating Example 2  
(when 2 or more digit is turned ON at same time)**

●Fixed number depending on microcomputer’s standard

- V<sub>OH</sub> output fall voltage of high-breakdown port  
2 V (max.); | Current value | = at 18 mA
- Resistor value 43 V / 900 μA = 48 kΩ (min.)
- Power dissipation of internal circuit (CPU, ROM, RAM etc.) = 5 V X 15 mA = 75 mW

●Fixed number depending on use condition

- Apply voltage to V<sub>EE</sub> pin: V<sub>cc</sub> – 45 V
- Timing number 11; digit number 12; segment number 24
- Ratio of T<sub>off</sub> time corresponding T<sub>disp</sub> time: 1/16
- Turn ON segment number during repeat cycle: 114
- All segment number during repeat cycle: 264 (= 11 X 24)
- Total number of built-in resistor: for digit; 10, for segment; 22
- Digit pin current value: 18 (mA)
- Segment pin current value: 3 (mA)

- (1) Digit pin power dissipation  
 $\{18 \times 12 \times (1-1/16) \times 2\} / 11 = 36.82 \text{ mW}$
- (2) Segment pin power dissipation  
 $\{3 \times 114 \times (1-1/16) \times 2\} / 11 = 58.30 \text{ mW}$
- (3) Pull-down resistor power dissipation (digit)  
 $(45 - 2)^2 / 48 \times (12 \times 10/12) \times (1 - 1/16) / 11 = 32.84 \text{ mW}$
- (4) Pull-down resistor power dissipation (segment)  
 $(45 - 2)^2 / 48 \times (114 \times 22/24) \times (1 - 1/16) / 11 = 343.08 \text{ mW}$
- (5) Internal circuit power dissipation (CPU, ROM, RAM etc.) = 75 mW

(1) + (2)+ (3) + (4) + (5) = 547 mW

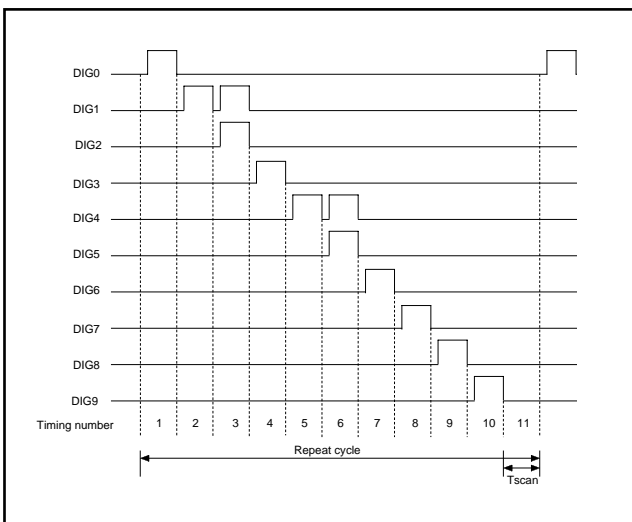

Fig. 76 Digit timing waveform (2)

**ABSOLUTE MAXIMUM RATINGS**

**Table 12 Absolute maximum ratings**

Symbol	Parameter	Conditions	Ratings	Unit
V <sub>CC</sub>	Power source voltage	All voltages are based on V <sub>SS</sub> . Output transistors are cut off.	-0.3 to 6.5	V
V <sub>EE</sub>	Pull-down power source voltage		V <sub>CC</sub> - 45 to V <sub>CC</sub> +0.3 (Note 1)	V
			V <sub>CC</sub> - 42 to V <sub>CC</sub> +0.3 (Note 2)	V
V <sub>I</sub>	Input voltage P47, P50-P57, P61-P65, P70-P77, P84-P87, P90, P91		-0.3 to V <sub>CC</sub> +0.3	V
V <sub>I</sub>	Input voltage P40-P46, P60		-0.3 to 13	V
V <sub>I</sub>	Input voltage P00-P07, P20-P27, P80-P83		V <sub>CC</sub> - 45 to V <sub>CC</sub> +0.3 (Note 1)	V
			V <sub>CC</sub> - 42 to V <sub>CC</sub> +0.3 (Note 2)	V
V <sub>I</sub>	Input voltage $\overline{\text{RESET}}$ , X <sub>IN</sub>		-0.3 to V <sub>CC</sub> +0.3	V
V <sub>I</sub>	Input voltage X <sub>CIN</sub>		-0.3 to V <sub>CC</sub> +0.3	V
V <sub>O</sub>	Output voltage P00-P07, P10-P17, P20-P27, P30-P37, P80-P83		V <sub>CC</sub> - 45 to V <sub>CC</sub> +0.3 (Note 1)	V
			V <sub>CC</sub> - 42 to V <sub>CC</sub> +0.3 (Note 2)	V
V <sub>O</sub>	Output voltage P50-P57, P61-P65, P70-P77, P84-P87, P90, P91, X <sub>OUT</sub> , X <sub>COUT</sub>		-0.3 to V <sub>CC</sub> +0.3	V
V <sub>O</sub>	Output voltage P40-P46, P60		-0.3 to 13	V
P <sub>d</sub>	Power dissipation	T <sub>a</sub> = -20 to 65 °C	800	mW
		T <sub>a</sub> = 65 to 85 °C	800 - 12.5 × (T <sub>a</sub> - 65)	mW
T <sub>opr</sub>	Operating temperature		-20 to 85	°C
T <sub>stg</sub>	Storage temperature		-40 to 125	°C

**Notes 1:** When V<sub>CC</sub> is 4.0 to 5.5 V.

**2:** When V<sub>CC</sub> is 2.7 to 4.0 V.

**RECOMMENDED OPERATING CONDITIONS**

**Table 13 Recommended operating conditions (1)**

(Vcc = 2.7 to 5.5 V, Ta = -20 to 85 °C, unless otherwise noted)

Symbol	Parameter		Limits			Unit	
			Min.	Typ.	Max.		
VCC	Power source voltage	In high-speed mode	4.0	5.0	5.5	V	
		In middle-/low-speed mode, 2 MHz or less in high-speed mode	2.7	5.0	5.5	V	
VSS	Power source voltage			0		V	
VEE	Pull-down power source voltage	VCC = 4.0 to 5.5 V	VCC-43		VCC	V	
		VCC = 2.7 to 4.0 V	VCC-40		VCC	V	
VREF	Analog reference voltage (when A-D converter is used)		2.0		VCC	V	
AVSS	Analog power source voltage			0		V	
VIA	Analog input voltage	AN0-AN11	0		VCC	V	
VIH	"H" input voltage	P40-P47, P50-P57, P60-P65, P70-P77, P90, P91	VCC = 4.0 to 5.5 V	0.75VCC		VCC	V
			VCC = 2.7 to 4.0 V	0.8VCC		VCC	V
VIH	"H" input voltage	P84-P87	VCC = 4.0 to 5.5 V	0.4VCC		VCC	V
			VCC = 2.7 to 4.0 V	0.5VCC		VCC	V
VIH	"H" input voltage	P00-P07	0.8VCC		VCC	V	
VIH	"H" input voltage	P20-P27, P80-P83	VCC = 4.0 to 5.5 V	0.52VCC		VCC	V
			VCC = 2.7 to 4.0 V	0.75VCC		VCC	V
VIH	"H" input voltage	RESET	0.8VCC		VCC	V	
VIH	"H" input voltage	XIN, XCIN	0.8VCC		VCC	V	
VIL	"L" input voltage	P40-P47, P50-P57, P60-P65, P70-P77, P90, P91	VCC = 4.0 to 5.5 V	0	0.25VCC	V	
			VCC = 2.7 to 4.0 V	0	0.2VCC	V	
VIL	"L" input voltage	P84-P87	0		0.16VCC	V	
VIL	"L" input voltage	P00-P07, P20-P27, P80-P83	0		0.2VCC	V	
VIL	"L" input voltage	RESET	0		0.2VCC	V	
VIL	"L" input voltage	XIN, XCIN	0		0.2VCC	V	

**Table 14 Recommended operating conditions (2)**

(V<sub>CC</sub> = 2.7 to 5.5 V, T<sub>a</sub> = -20 to 85 °C, unless otherwise noted)

Symbol	Parameter	Limits			Unit
		Min.	Typ.	Max.	
ΣIOH(peak)	"H" total peak output current ( <b>Note 1</b> ) P00-P07, P10-P17, P20-P27, P30-P37, P80-P83			-240	mA
ΣIOH(peak)	"H" total peak output current ( <b>Note 1</b> ) P50-P57, P61-P65, P70-P77, P90, P91			-60	mA
ΣIOL(peak)	"L" total peak output current ( <b>Note 1</b> ) P50-P57, P60-P65, P70-P77, P90, P91			100	mA
ΣIOL(peak)	"L" total peak output current ( <b>Note 1</b> ) P40-P46, P84-P87			60	mA
ΣIOH(avg)	"H" total average output current ( <b>Note 1</b> ) P00-P07, P10-P17, P20-P27, P30-P37, P80-P87			-120	mA
ΣIOH(avg)	"H" total average output current ( <b>Note 1</b> ) P50-P57, P61-P65, P70-P77, P90, P91			-30	mA
ΣIOL(avg)	"L" total average output current ( <b>Note 1</b> ) P50-P57, P60-P65, P70-P77, P90, P91			50	mA
ΣIOL(avg)	"L" total average output current ( <b>Note 1</b> ) P40-P46, P84-P87			30	mA
IOH(peak)	"H" peak output current ( <b>Note 2</b> ) P00-P07, P10-P17, P20-P27, P30-P37, P80-P83			-40	mA
IOH(peak)	"H" peak output current ( <b>Note 2</b> ) P50-P57, P61-P65, P70-P77, P84-P87, P90, P91			-10	mA
IOL(peak)	"L" peak output current ( <b>Note 2</b> ) P50-P57, P61-P65, P70-P77, P84-P87, P90, P91			10	mA
IOL(peak)	"L" peak output current ( <b>Note 2</b> ) P40-P46, P60			30	mA
IOH(avg)	"H" average output current ( <b>Note 3</b> ) P00-P07, P10-P17, P20-P27, P30-P37, P80-P83			-18	mA
IOH(avg)	"H" average output current ( <b>Note 3</b> ) P50-P57, P60-P65, P70-P77, P84-P87, P90, P91			-5	mA
IOL(avg)	"L" average output current ( <b>Note 3</b> ) P50-P57, P61-P65, P70-P77, P84-P87, P90, P91			5	mA
IOL(avg)	"L" average output current ( <b>Note 3</b> ) P40-P46, P60			15	mA
f(CNTR0)	Clock input frequency for timers 2, 4, and X (duty cycle 50 %)	V <sub>CC</sub> = 4.0 to 5.5 V		250	kHz
f(CNTR1)		V <sub>CC</sub> = 2.7 to 4.0 V		100	kHz
f(XIN)	Main clock input oscillation frequency ( <b>Note 4</b> )	V <sub>CC</sub> = 4.0 to 5.5 V		4.2	MHz
		V <sub>CC</sub> = 2.7 to 4.0 V		2	MHz
f(XCIN)	Sub-clock input oscillation frequency ( <b>Notes 4, 5</b> )		32.768	50	kHz

**Notes 1:** The total output current is the sum of all the currents flowing through all the applicable ports. The total average current is an average value measured over 100 ms. The total peak current is the peak value of all the currents.

**2:** The peak output current is the peak current flowing in each port.

**3:** The average output current IOL (avg), IOH(avg) in an average value measured over 100 ms.

**4:** When the oscillation frequency has a duty cycle of 50%.

**5:** When using the microcomputer in low-speed mode, set the sub-clock input oscillation frequency on condition that f(XCIN) < f(XIN)/3.

**ELECTRICAL CHARACTERISTICS**

**Table 15 Electrical characteristics (1)**

(VCC = 2.7 to 5.5 V, Ta = -20 to 85 °C, unless otherwise noted)

Symbol	Parameter		Test conditions	Limits			Unit
				Min.	Typ.	Max.	
VOH	"H" output voltage	P00–P07, P10–P17, P20–P27, P30–P37, P80–P83	VCC = 4.0 to 5.5 V	IOH = -18 mA	VCC-2.0		V
			VCC = 2.7 to 4.0 V	IOH = -10 mA	VCC-1.5		V
VOH	"H" output voltage	P50–P57, P60–P65, P70–P77, P84–P87, P90, P91	VCC = 4.0 to 5.5 V	IOH = -10 mA	VCC-2.0		V
			VCC = 2.7 to 4.0 V	IOH = -10 mA	VCC-1.0		V
VOL	"L" output voltage	P50–P57, P61–P65, P84–P87, P90, P91	VCC = 4.0 to 5.5 V	IOL = 10 mA		2.0	V
			VCC = 2.7 to 4.0 V	IOL = 1.6 mA		0.4	V
VOL	"L" output voltage	P40–P46, P60	VCC = 4.0 to 5.5 V	IOL = 15 mA	0.6	2.0	V
			VCC = 2.7 to 4.0 V	IOL = 5 mA	0.3	1.0	V
VT+–VT-	Hysteresis	P40–P42, P45–P47, P5, P60, P61, P64 (Note 1)			0.4		V
VT+–VT-	Hysteresis	RESET, XIN			0.5		V
VT+–VT-	Hysteresis	XCIN			0.5		μA
IiH	"H" input current	P47, P50–P57, P61–P65, P70–P77, P84–P87	Vi = VCC			5.0	μA
IiH	"H" input current	P40–P46, P60	Vi = 12 V			10.0	μA
IiH	"H" input current	P00–P07, P20–P27, P80–P83 (Note 2)	Vi = VCC			5.0	μA
IiH	"H" input current	RESET, XCIN	Vi = VCC			5.0	μA
IiH	"H" input current	XIN	Vi = VCC		4.0		μA
IiL	"L" input current	P40–P47, P60	Vi = VSS			-5.0	μA
IiL	"L" input current	P50–P57, P61–P65, P70–P77, P84–P87, P90, P91	Vi = VSS			-5.0	μA
			Pull-up "off"				
			VCC = 5 V, Vi = VSS		-70		μA
IiL	"L" input current	P00–P07, P20–P27, P80–P83 (Note 2)	VCC = 3 V, Vi = VSS		-25		μA
			Pull-up "on"				
IiL	"L" input current	RESET, XCIN	Vi = VSS			-5.0	μA
IiL	"L" input current	XIN	Vi = VSS		-4.0		μA
RPULLD	Pull-down resistor	P00–P07, P10–P17, P30–P37 (P20–P27, P80–P83 at option)	VEE = VCC-43 V, VOL = VCC	143	72	47	kΩ
Ileak	Output leak current	P00–P07, P10–P17, P20–P27, P30–P37, P80–P83	VEE = VCC-43 V, VOL = VCC-43 V			-10	μA
IreadH	"H" read current	P00–P07, P20–P27, P80–P83	Vi = 5 V		1		μA
VRAM	RAM hold voltage		When clock is stopped	2		VCC	V

Notes 1: P42, P45, P46, and P60 of the mask option type P do not have hysteresis characteristics.

2: Except when reading ports P0, P2, or P8.

**Table 16 Electrical characteristics (2)**

(VCC = 2.7 to 5.5 V, Ta = -20 to 85 °C, unless otherwise noted)

Symbol	Parameter	Test conditions	Limits			Unit
			Min.	Typ.	Max.	
I <sub>CC</sub>	Power source current	High-speed mode f(X <sub>IN</sub> ) = 4.2 MHz f(X <sub>CIN</sub> ) = 32 kHz Output transistors "off"		7.5		mA
		High-speed mode f(X <sub>IN</sub> ) = 4.2 MHz (in WIT state) f(X <sub>CIN</sub> ) = 32 kHz Output transistors "off"		1		mA
		Middle-speed mode f(X <sub>IN</sub> ) = 4.2 MHz f(X <sub>CIN</sub> ) = stopped Output transistors "off"		3		mA
		Middle-speed mode f(X <sub>IN</sub> ) = 4.2 MHz (in WIT state) f(X <sub>CIN</sub> ) = stopped Output transistors "off"		1		mA
		Low-speed mode f(X <sub>IN</sub> ) = stopped f(X <sub>CIN</sub> ) = 32 kHz Low-power dissipation mode (CM3 = 0) Output transistors "off"		60		μA
		Low-speed mode f(X <sub>IN</sub> ) = stopped f(X <sub>CIN</sub> ) = 32 kHz (in WIT state) Low-power dissipation mode (CM3 = 0) Output transistors "off"		20		μA
		Increment when A-D conversion is executed		0.6		mA
		All oscillation stopped (in STP state) Output transistors "off"	Ta = 25 °C	0.1	1	μA
	Ta = 85 °C		10	μA		

**A-D converter characteristics**

**Table 17 A-D converter characteristics (1)**

(VCC = 4.0 to 5.5 V, VSS = 0 V, Ta = -20 to 85 °C, f(X<sub>IN</sub>) = 250 kHz to 4.2 MHz in high-speed mode, unless otherwise noted)

Symbol	Parameter	Test conditions	Limits			Unit
			Min.	Typ.	Max.	
—	Resolution				10	Bits
—	Absolute accuracy (excluding quantization error)	VCC = VREF = 5.12 V		±1	±2.5	LSB
T <sub>CONV</sub>	Conversion time		61		62	tc(φ)
I <sub>VREF</sub>	Reference input current	VREF = 5.0 V	50	150	200	μA
I <sub>IA</sub>	Analog port input current			0.5	5.0	μA
RLADDER	Ladder resistor			35		kΩ

**Table 18 A-D converter characteristics (2)**

(VCC = 2.7 to 4.0 V, VSS = 0 V, Ta = -20 to 85 °C, f(X<sub>IN</sub>) = 250 kHz to 2 MHz in high-speed mode, unless otherwise noted)

Symbol	Parameter	Test conditions	Limits			Unit
			Min.	Typ.	Max.	
—	Resolution				10	Bits
—	Absolute accuracy (excluding quantization error)	VCC = VREF = 3.3 V		±3	±6	LSB
T <sub>CONV</sub>	Conversion time		61		62	tc(φ)
I <sub>VREF</sub>	Reference input current	VREF = 3.3 V	30	95	120	μA
I <sub>IA</sub>	Analog port input current			0.5	5.0	μA
RLADDER	Ladder resistor			35		kΩ

## TIMING REQUIREMENTS

Table 19 Timing requirements (1)

(VCC = 4.0 to 5.5 V, VSS = 0 V, Ta = -20 to 85 °C, unless otherwise noted)

Symbol	Parameter	Limits			Unit
		Min.	Typ.	Max.	
t <sub>w</sub> (RESET)	Reset input "L" pulse width	2.0			μs
t <sub>c</sub> (XIN)	Main clock input cycle time (XIN input)	238			ns
t <sub>WH</sub> (XIN)	Main clock input "H" pulse width	60			ns
t <sub>WL</sub> (XIN)	Main clock input "L" pulse width	60			ns
t <sub>c</sub> (XCIN)	Sub-clock input cycle time (XCIN input)	20			μs
t <sub>WH</sub> (XCIN)	Sub-clock input "H" pulse width	5.0			μs
t <sub>WL</sub> (XCIN)	Sub-clock input "L" pulse width	5.0			μs
t <sub>c</sub> (CNTR)	CNTR0, CNTR1 input cycle time	4.0			μs
t <sub>WH</sub> (CNTR)	CNTR0, CNTR1 input "H" pulse width	1.6			μs
t <sub>WL</sub> (CNTR)	CNTR0, CNTR1 input "L" pulse width	1.6			μs
t <sub>WH</sub> (INT)	INT0 to INT4 input "H" pulse width	80			ns
t <sub>WL</sub> (INT)	INT0 to INT4 input "L" pulse width	80			ns
t <sub>c</sub> (SCLK)	Serial I/O clock input cycle time	0.95			μs
t <sub>WH</sub> (SCLK)	Serial I/O clock input "H" pulse width	400			ns
t <sub>WL</sub> (SCLK)	Serial I/O clock input "L" pulse width	400			ns
t <sub>su</sub> (SCLK-SIN)	Serial I/O input set up time	200			ns
t <sub>h</sub> (SCLK-SIN)	Serial I/O input hold time	200			ns

Table 20 Timing requirements (2)

(VCC = 2.7 to 5.5 V, VSS = 0 V, Ta = -20 to 85 °C, unless otherwise noted)

Symbol	Parameter	Limits			Unit
		Min.	Typ.	Max.	
t <sub>w</sub> (RESET)	Reset input "L" pulse width	2.0			μs
t <sub>c</sub> (XIN)	Main clock input cycle time (XIN input)	500			ns
t <sub>WH</sub> (XIN)	Main clock input "H" pulse width	120			ns
t <sub>WL</sub> (XIN)	Main clock input "L" pulse width	120			ns
t <sub>c</sub> (XCIN)	Sub-clock input cycle time (XCIN input)	20			μs
t <sub>WH</sub> (XCIN)	Sub-clock input "H" pulse width	5.0			μs
t <sub>WL</sub> (XCIN)	Sub-clock input "L" pulse width	5.0			μs
t <sub>c</sub> (CNTR)	CNTR0, CNTR1 input cycle time	10			μs
t <sub>WH</sub> (CNTR)	CNTR0, CNTR1 input "H" pulse width	4.0			μs
t <sub>WL</sub> (CNTR)	CNTR0, CNTR1 input "L" pulse width	4.0			μs
t <sub>WH</sub> (INT)	INT0 to INT4 input "H" pulse width	230			ns
t <sub>WL</sub> (INT)	INT0 to INT4 input "L" pulse width	230			ns
t <sub>c</sub> (SCLK)	Serial I/O clock input cycle time	2.0			μs
t <sub>WH</sub> (SCLK)	Serial I/O clock input "H" pulse width	950			ns
t <sub>WL</sub> (SCLK)	Serial I/O clock input "L" pulse width	950			ns
t <sub>su</sub> (SCLK-SIN)	Serial I/O input set up time	400			ns
t <sub>h</sub> (SCLK-SIN)	Serial I/O input hold time	300			ns



## SWITCHING CHARACTERISTICS

Table 21 Switching characteristics (1)

(V<sub>CC</sub> = 4.0 to 5.5 V, V<sub>SS</sub> = 0 V, T<sub>a</sub> = -20 to 85 °C, unless otherwise noted)

Symbol	Parameter	Test conditions	Limits			Unit
			Min.	Typ.	Max.	
t <sub>WH</sub> (SCLK)	Serial I/O clock output "H" pulse width	CL = 100 pF	tc(SCLK)/2-160			ns
t <sub>WL</sub> (SCLK)	Serial I/O clock output "L" pulse width	CL = 100 pF	tc(SCLK)/2-160			ns
t <sub>d</sub> (SCLK-SOUT)	Serial I/O output delay time				0.2 tc	ns
t <sub>v</sub> (SCLK-SOUT)	Serial I/O output valid time		0			ns
t <sub>r</sub> (SCLK)	Serial I/O clock output rising time	CL = 100 pF			40	ns
t <sub>f</sub> (SCLK)	Serial I/O clock output falling time	CL = 100 pF			40	ns
t <sub>r</sub> (Pch-strg)	P-channel high-breakdown voltage output rising time ( <b>Note 1</b> )	CL = 100 pF V <sub>EE</sub> = V <sub>CC</sub> -43 V		55		ns
t <sub>r</sub> (Pch-weak)	P-channel high-breakdown voltage output rising time ( <b>Note 2</b> )	CL = 100 pF V <sub>EE</sub> = V <sub>CC</sub> -43 V		1.8		μs

**Notes 1:** When bit 7 of the FLDC mode register (address 0EF416) is at "0".**2:** When bit 7 of the FLDC mode register (address 0EF416) is at "1".

Table 22 Switching characteristics (2)

(V<sub>CC</sub> = 2.7 to 4.0 V, V<sub>SS</sub> = 0 V, T<sub>a</sub> = -20 to 85 °C, unless otherwise noted)

Symbol	Parameter	Test conditions	Limits			Unit
			Min.	Typ.	Max.	
t <sub>WH</sub> (SCLK)	Serial I/O clock output "H" pulse width	CL = 100 pF	tc(SCLK)/2-240			ns
t <sub>WL</sub> (SCLK)	Serial I/O clock output "L" pulse width	CL = 100 pF	tc(SCLK)/2-240			ns
t <sub>d</sub> (SCLK-SOUT)	Serial I/O output delay time				0.4 tc	ns
t <sub>v</sub> (SCLK-SOUT)	Serial I/O output valid time		0			ns
t <sub>r</sub> (SCLK)	Serial I/O clock output rising time	CL = 100 pF			60	ns
t <sub>f</sub> (SCLK)	Serial I/O clock output falling time	CL = 100 pF			60	ns
t <sub>r</sub> (Pch-strg)	P-channel high-breakdown voltage output rising time ( <b>Note 1</b> )	CL = 100 pF V <sub>EE</sub> = V <sub>CC</sub> -40 V		140		ns
t <sub>r</sub> (Pch-weak)	P-channel high-breakdown voltage output rising time ( <b>Note 2</b> )	CL = 100 pF V <sub>EE</sub> = V <sub>CC</sub> -40 V		3.6		μs

**Notes 1:** When bit 7 of the FLDC mode register (address 0EF416) is at "0".**2:** When bit 7 of the FLDC mode register (address 0EF416) is at "1".

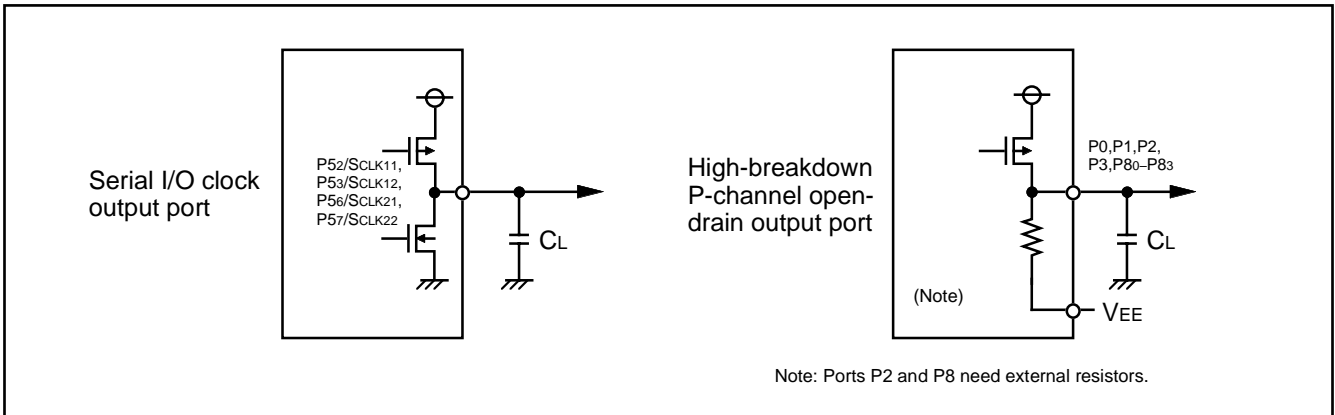

Fig. 77 Circuit for measuring output switching characteristics

Timing Diagram

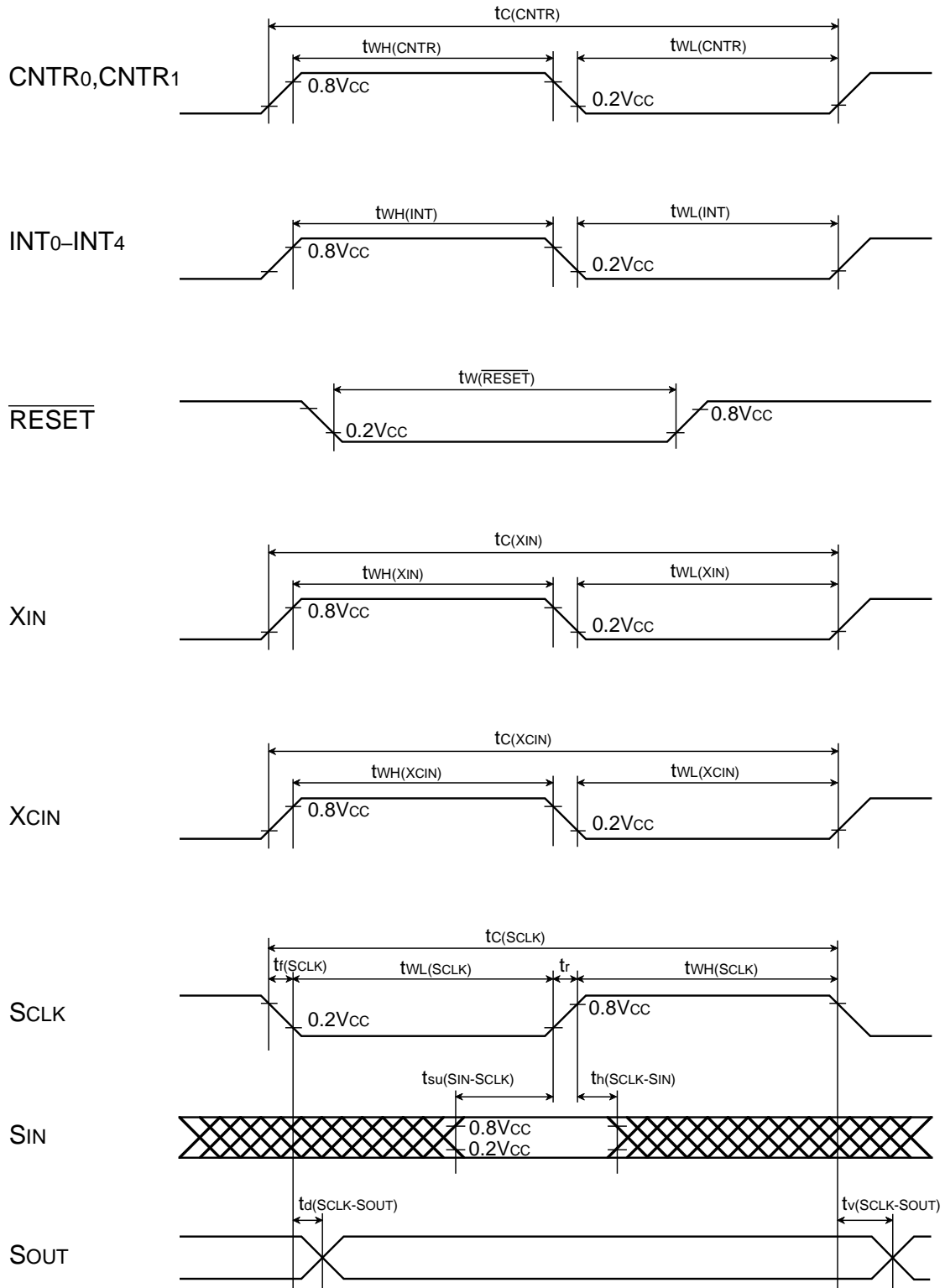

Fig. 78 Timing diagram

PACKAGE OUTLINE

80P6N-A

Plastic 80pin 14X20mm body QFP

EIAJ Package Code	JEDEC Code	Weight(g)	Lead Material
QFP80-P-1420-0.80	-	1.58	Alloy 42

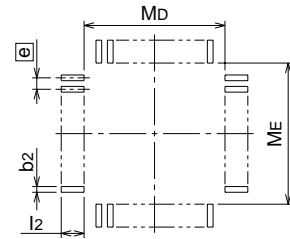
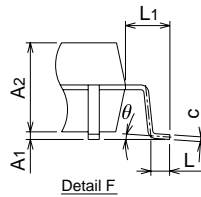
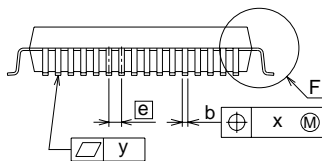
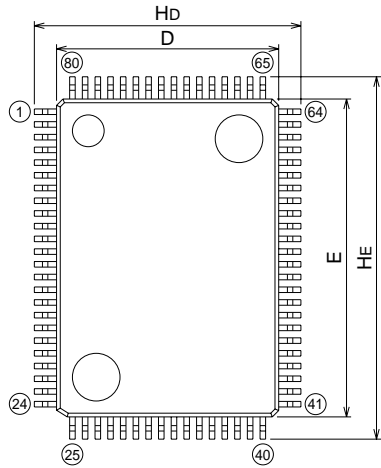

Recommended Mount Pad

Symbol	Dimension in Millimeters		
	Min	Nom	Max
A	-	-	3.05
A1	0	0.1	0.2
A2	-	2.8	-
b	0.3	0.35	0.45
c	0.13	0.15	0.2
D	13.8	14.0	14.2
E	19.8	20.0	20.2
e	-	0.8	-
Hd	16.5	16.8	17.1
HE	22.5	22.8	23.1
L	0.4	0.6	0.8
L1	-	1.4	-
x	-	-	0.2
y	-	-	0.1
$\theta$	0°	-	10°
b2	-	0.5	-
l2	1.3	-	-
Md	-	14.6	-
ME	-	20.6	-



# MITSUBISHI ELECTRIC CORPORATION

HEAD OFFICE: 2-2-3, MARUNOUCHI, CHIYODA-KU, TOKYO 100-8310, JAPAN

## Keep safety first in your circuit designs!

- Mitsubishi Electric Corporation puts the maximum effort into making semiconductor products better and more reliable, but there is always the possibility that trouble may occur with them. Trouble with semiconductors may lead to personal injury, fire or property damage. Remember to give due consideration to safety when making your circuit designs, with appropriate measures such as (i) placement of substitutive, auxiliary circuits, (ii) use of non-flammable material or (iii) prevention against any malfunction or mishap.

## Notes regarding these materials

- These materials are intended as a reference to assist our customers in the selection of the Mitsubishi semiconductor product best suited to the customer's application; they do not convey any license under any intellectual property rights, or any other rights, belonging to Mitsubishi Electric Corporation or a third party.
- Mitsubishi Electric Corporation assumes no responsibility for any damage, or infringement of any third-party's rights, originating in the use of any product data, diagrams, charts, programs, algorithms, or circuit application examples contained in these materials.
- All information contained in these materials, including product data, diagrams, charts, programs and algorithms represents information on products at the time of publication of these materials, and are subject to change by Mitsubishi Electric Corporation without notice due to product improvements or other reasons. It is therefore recommended that customers contact Mitsubishi Electric Corporation or an authorized Mitsubishi Semiconductor product distributor for the latest product information before purchasing a product listed herein.  
The information described here may contain technical inaccuracies or typographical errors. Mitsubishi Electric Corporation assumes no responsibility for any damage, liability, or other loss rising from these inaccuracies or errors. Please also pay attention to information published by Mitsubishi Electric Corporation by various means, including the Mitsubishi Semiconductor home page (<http://www.mitsubishichips.com>).
- When using any or all of the information contained in these materials, including product data, diagrams, charts, programs, and algorithms, please be sure to evaluate all information as a total system before making a final decision on the applicability of the information and products. Mitsubishi Electric Corporation assumes no responsibility for any damage, liability or other loss resulting from the information contained herein.
- Mitsubishi Electric Corporation semiconductors are not designed or manufactured for use in a device or system that is used under circumstances in which human life is potentially at stake. Please contact Mitsubishi Electric Corporation or an authorized Mitsubishi Semiconductor product distributor when considering the use of a product contained herein for any specific purposes, such as apparatus or systems for transportation, vehicular, medical, aerospace, nuclear, or undersea repeater use.
- The prior written approval of Mitsubishi Electric Corporation is necessary to reprint or reproduce in whole or in part these materials.
- If these products or technologies are subject to the Japanese export control restrictions, they must be exported under a license from the Japanese government and cannot be imported into a country other than the approved destination.  
Any diversion or reexport contrary to the export control laws and regulations of Japan and/or the country of destination is prohibited.
- Please contact Mitsubishi Electric Corporation or an authorized Mitsubishi Semiconductor product distributor for further details on these materials or the products contained therein.

REVISION DESCRIPTION LIST

38B4 GROUP DATA SHEET

Rev. No.	Revision Description	Rev. date
1.0	First Edition	000510