

SIEMENS

HIGH EFFICIENCY RED MPD 2545 ^{T-41-37}

GREEN MPD 2547

YELLOW MPD 2548

**.25" 4-Character, 5x7 Dot Matrix, X-Y Stackable,
HI-REL/Military Alphanumeric Programmable Display™
with Built-In CMOS Control Functions**

Intelligent
Display Devices

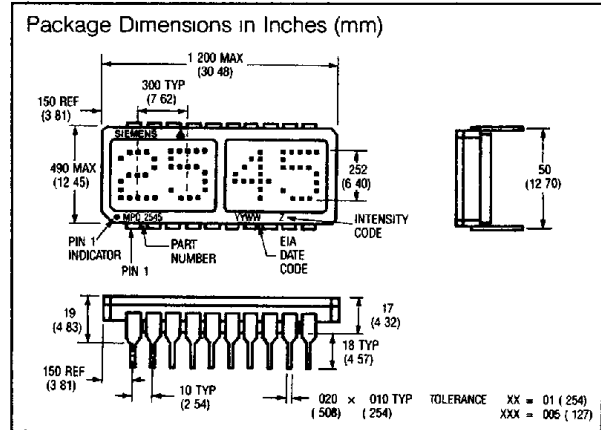
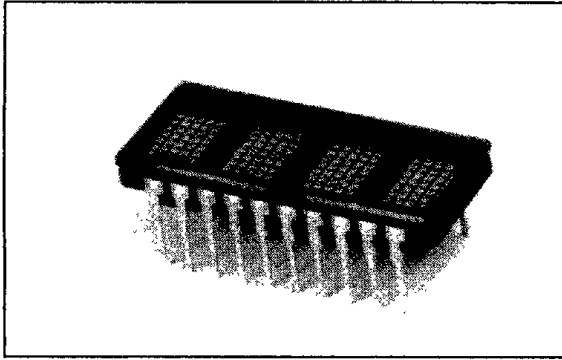

FEATURES

- Four .25" Dot Matrix Characters in Hermetic Package
- Conforms to MIL-D-87157 Quality Level A Test Table
- Built-in Memory, Decoders, Multiplexer and Drivers
- Viewing Angle, X Axis $\pm 40^\circ$, Y Axis $\pm 75^\circ$
- 96-Character ASCII Format (Both Upper and Lower Case Characters)
- Rugged Ceramic Package, Hermetic Sealed Flat Glass Window
- Wide Temperature Operating Range for High Reliability Industrial and Military Use, -55°C to $+100^\circ\text{C}$
- 8-Bit Bidirectional Data BUS
- READ/WRITE Capability
- Built-In Character Generator ROM
- TTL Compatible
- Easily Cascaded for Multidisplay Operation
- Less CPU Time Required
- Software Controlled Features:
 - Programmable Highlight Attribute (Blinking, Non-Blinking)
 - Asynchronous Memory Clear Function
 - Lamp Test
 - Display Blank Function
 - Single or Multiple Character Blinking Function
 - Three Programmable Brightness Levels

Important: Refer to Appnote 18, "Using and Handling Intelligent Displays." Since this is a CMOS device, normal precautions should be taken to avoid static damage.

GENERAL DESCRIPTION

The MPD 2545 (high efficiency red/orange), MPD 2547 (green), and MPD 2548 (yellow) are four-digit High Reliability dot matrix Programmable Displays that are aimed at satisfying the most demanding Military display requirements. They are designed for use in extremely harsh environments where only the most reliable product is acceptable. These devices are processed to meet the requirements of HI-REL/Military applications. The devices are constructed in a hermetic package using four .25-inch-high 5x7 dot matrix displays. The devices incorporate the latest in CMOS technology which is the heart of the device intelligence. The CMOS controller chip is controlled by a user-supplied eight-bit data word on the bidirectional BUS. The ASCII data and attribute data are word driven. This approach allows the MPD 2545/2547/2548 to interface using the same techniques as a microprocessor peripheral.

APPLICATIONS

- Military Control Panels
- Night Viewing Applications (Red Light)
- Cockpit Monitors
- Night Vision Goggle Viewable Displays (Green)
- Portable and Vehicle Technology
- Industrial Controllers

Maximum Ratings

DC Supply	-0.5 V to +6.0 Vdc
Input Voltage Relative to GND (all inputs)	-0.5 V to $V_{CC} + 0.5$ Vdc
Operating Temperature	-55°C to $+100^\circ\text{C}$
Storage Temperature	-55°C to $+150^\circ\text{C}$
Thermal Resistance (θ_{JC})	30°C/W

T-41-37

OPTICAL CHARACTERISTICS

High Efficiency Red MPD 2545

Description	Symbol	Min.	Typ. ⁽⁴⁾	Max.	Units	Test Conditions
Luminous Intensity per LED ^(1, 3) (Character Average)	I _{vave}	75	150		μcd	V _{CC} = 5.0 V, # sign "ON" on all digits at full brightness, T _{amb} = 25°C
Peak Wavelength	λ _{PEAK}		635		nm	
Dominant Wavelength ⁽²⁾	λ _D		630		nm	

High Efficiency Green MPD 2547

Description	Symbol	Min.	Typ. ⁽⁴⁾	Max.	Units	Test Conditions
Luminous Intensity per LED ^(1, 3) (Character Average)	I _{vave}	75	150		μcd	V _{CC} = 5.0 V, # sign "ON" on all digits at full brightness, T _{amb} = 25°C
Peak Wavelength	λ _{PEAK}		565		nm	
Dominant Wavelength ⁽²⁾	λ _D		570		nm	

Yellow MPD 2548

Description	Symbol	Min.	Typ. ⁽⁴⁾	Max.	Units	Test Conditions
Luminous Intensity per LED ^(1, 3) (Character Average)	I _{vave}	75	150		μcd	V _{CC} = 5.0 V, # sign "ON" on all digits at full brightness, T _{amb} = 25°C
Peak Wavelength	λ _{PEAK}		585		nm	
Dominant Wavelength ⁽²⁾	λ _D		590		nm	

Notes:

- 1 The displays are categorized for luminous intensity with the intensity category designated by a letter code on the bottom of the package
- 2 Dominant wavelength λ_D is derived from the CIE chromaticity diagram, and represents the single wavelength which defines the color of the device

3 The luminous sterance of the LED may be calculated using the following relationships

$$L_v \text{ (cd/m}^2\text{)} = I_v \text{ (Candela)/A (Meter)}^2$$

$$L_v \text{ (Footlamberts)} = \pi I_v \text{ (Candela)/A (Foot)}^2$$

$$A = 8.4 \times 10^{-7} \text{ ft}^2, 7.8 \times 10^{-6} \text{ m}^2$$

4 All typical values specified at V_{CC} = 5.0 V and T_{amb} = 25°C unless otherwise noted

DC CHARACTERISTICS

Parameter	-55°C			+25°C			+100°C			Units	Conditions
	Min.	Typ.	Max.	Min.	Typ.	Max.	Min.	Typ.	Max.		
I _{CC} Blank (All Inputs Low)		4	10		2.0	5.0		1	2.5	mA	V _{CC} = 5 V
I _{CC} 80 dots/unit (100% Brightness)		220	250		160	190		125	160	mA	V _{CC} = 5 V
V _{IL} (all inputs)			0.8			0.8			0.8	V	V _{CC} = 5 V ± 0.5 V
V _{IH} (all inputs)	2.0			2.0			2.0			V	V _{CC} = 5 V ± 0.5 V
I _{IL} (all inputs)		70	120		60	100		50	80	μA	V _{IN} = 0.8 V V _{CC} = 5.0 V

SWITCHING SPECIFICATIONS (@V_{CC} = 4.5 V)

		WRITE CYCLE TIMING		
Parameter	Description	Specification (ns)		
		-55°C	+25°C	+100°C
T _{WD}	Delay time for write pulse after control signals and data (min.)	25	50	75
T _{DH}	Data hold after write pulse (min.)	25	50	75
T _{WR}	Write pulse width	50	100	150
T _{WC}	Total write cycle time (min.)	100	200	300

- Notes 1 TRD=TRC-TAD-(TACC-TDD)
- 2 TWR=TWC-(TWD+TDH)

SWITCHING SPECIFICATIONS (@V_{CC} = 4.5 V) (Continued)

READ CYCLE TIMING		Specification (ns)		
Parameter	Description	-55°C	+25°C	+100°C
T _{AD}	Address set up delay after CE (min.)	0	0	10
T _{ACC}	Access time for data valid after address (max)	100	175	200
T _{DD}	Delay time for data valid after read pulse (max)	100	150	175
T _{DH}	Data valid after end of read pulse (min)	0	0	0
T _{RD}	Read Pulse (min.)	150	175	200
T _{RC}	Total read cycle time (min)	150	200	235

Notes 1 TRD = TRC - TAD - (TACC - TDD)
 2 TWR = TWC - (TWD + TDH)

TIMING CHARACTERISTICS @V_{CC} = 4.5 V

DATA "WRITE" CYCLE

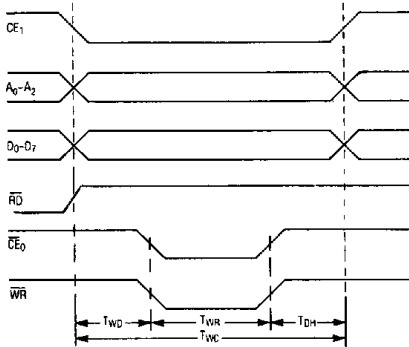

Note T_{RD} = T_{RC} - T_{AD} - (T_{ACC} - T_{DD})

DATA "READ" CYCLE

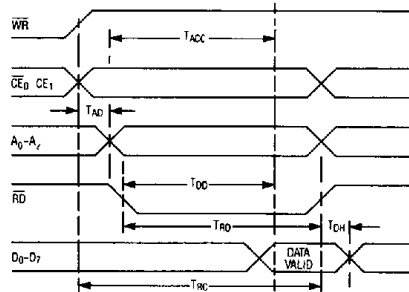

TIMING MEASUREMENT LEVELS

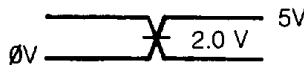

TOP VIEW

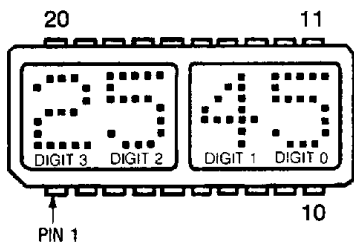

PIN ASSIGNMENTS

PINOUT			
Pin	Function	Pin	Function
1	\overline{RD} READ	11	\overline{WR} WRITE
2	CLK I/O CLOCK I/O	12	D7 DATA MSB
3	CLKSEL CLOCK SELECT	13	D6 DATA
4	\overline{RST} RESET	14	D5 DATA
5	CE1 CHIP ENABLE	15	D4 DATA
6	$\overline{CE0}$ CHIP ENABLE	16	D3 DATA
7	A2 ADDRESS MSB	17	D2 DATA
8	A1 ADDRESS	18	D1 DATA
9	A0 ADDRESS LSB	19	D0 DATA LSB
10	GND	20	V _{CC}

PIN DEFINITIONS

- Pin
- 1 \overline{RD} Active low, will enable a processor to read all registers in the MPD 2545/7/8
- 2 CLK I/O If CLK SEL (pin 3) is low, then expect an external clock source into this pin. If CLK SEL is high, then this pin will be the master or source for all other devices which have CLK SEL low
- 3 CLK SEL CLoCK SElect, determines the action of pin 2. CLK I/O, see the section on Cascading for an example.
- 4 \overline{RST} Reset. Must be held low until V_{CC} > 4.5 volts. Reset is used only to synchronize blinking and will not clear the display
- 5 CE1 Chip enable (active high).
- 6 $\overline{CE0}$ Chip enable (active low)
- 7. A2 Address input (MSB).
- 8 A1 Address input.
- 9 A0 Address input (LSB)
- 10 GND Ground.
- 11 \overline{WR} Write. Active Low. If the device is selected, a low on the write input loads the data into memory.
- 12 D7 Data Bus bit 7 (MSB)
- 13 D6 Data Bus bit 6.
- 14 D5 Data Bus bit 5.
- 15. D4 Data Bus bit 4.
- 16. D3 Data Bus bit 3.
- 17. D2 Data Bus bit 2.
- 18. D1 Data Bus bit 1
- 19 D0 Data Bus bit 0 (LSB)
- 20. V_{CC} Plus 5 volts power pin

Intelligent Display Devices

T-41-37

DATA INPUT COMMANDS															
CE0	CE1	RD	WR	A2	A1	A0	D7	D6	D5	D4	D3	D2	D1	D0	OPERATION
1	0	X	X	X	X	X	X	X	X	X	X	X	X	X	No Change
0	1	0	1	1	0	0	X	X	X	X	X	X	X	X	Read Digit 0 Data To Bus
0	1	1	0	1	0	0	X	0	1	0	0	1	0	0	(\$) Written To Digit 0
0	1	1	0	1	0	1	X	1	0	1	0	1	1	1	(W) Written to Digit 1
0	1	1	0	1	1	0	X	1	1	0	0	1	1	0	(f) Written To Digit 2
0	1	1	0	1	1	1	X	0	1	1	0	0	1	1	(3) Written To Digit 3
0	1	1	0	1	0	0	1	X	X	X	X	X	X	X	Char Written To Digit 0 And Cursor Enabled

MODE SELECTION				
CE0	CE1	RD	WR	OPERATION
0	1	0	0	Illegal
1	X	X	X	No Change
X	0	X	X	No Change
X	X	1	1	No Change

NOTE: 0 = Low Logic Level 1 = High Logic Level X = Don't Care

BLOCK DIAGRAM

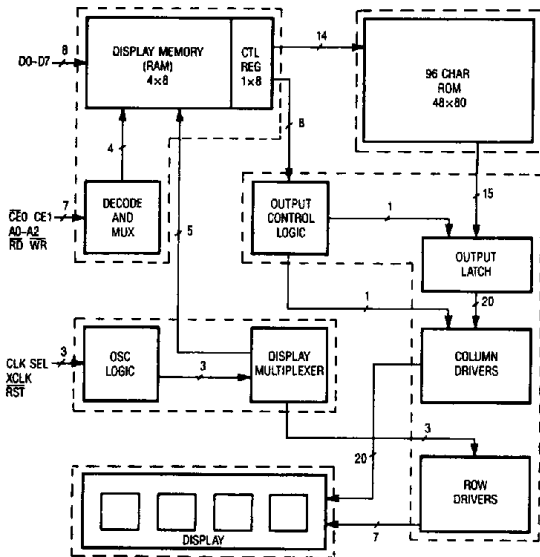

FUNCTIONAL DESCRIPTION

The MPD 2545/7/8 block diagram includes 5 major blocks and internal registers (indicated by dotted lines)

Display Memory consists of a 5x8 bit RAM block. Each of the four 8-bit words holds the 7-bit ASCII data (bits D0-D6). The fifth 8-bit memory word is used as a control register. A detailed description of the control register and its functions can be found under the heading Control Word. Each 8-bit word is addressable and can be read from or written to

The **Control Logic** dictates all of the features of the display device and is discussed in the Control Word section of this data sheet

The **Character Generator** converts the 7-bit ASCII data into the proper dot pattern for the 96 characters shown in the character set chart

The **Clock Source** can originate either from the internal oscillator clock or from an external source—usually from the output of another MPD 2545/7/8 in a multiple module display

The **Display Multiplexer** controls all display output to the digit drivers so no additional logic is required for a display system.

The **Column Drivers** are connected directly to the display.

The **Display** has four digits. Each of the four digits is comprised of 35 LEDs in a 5x7 dot array which makes up the alphanumeric characters.

The intensity of the display can be varied by the Control Word in steps of 0% (Blank), 25%, 50%, and full brightness.

MICROPROCESSOR INTERFACE

The interface to the microprocessor is through the address lines (A0-A2), the data bus (D0-D7), two chip select lines (CE0, CE1), and read (RD) and write (WR) lines

To derive the appropriate enable signal, the \overline{WR} and \overline{RD} lines should be "NANDED" into the CE1 input. The $\overline{CE0}$ should be held low when executing a read, or write operation

The read and write lines are both active low. During a valid read the data input lines (D0-D7) become outputs. A valid write will enable the data as input lines

INPUT BUFFERING

If a cable length of 6 inches or more is used, all inputs to the display should be buffered with a tri-state non-inverting buffer mounted as close to the display as conveniently possible. Recommended buffers are 74LS245 for the data lines and 74LS244 for the control lines

PROGRAMMING THE MPD 2545/7/8

There are five registers within the MPD 2545/7/8. Four of these registers are used to hold the ASCII code of the four display characters. The fifth register is the Control Word, which is used to blink, blank, clear or dim the entire display, or to change the presentation (attributes) of individual characters.

ADDRESSING

The addresses within the display device are shown below. Digit 0 is the rightmost digit of the display, while digit 3 is on the left. Although there is only one Control Word, it is duplicated at the four address locations 0-3. Data can be read from any of these locations. When one of these locations is written to, all of them will change together.

Address	Contents
0	Control Word
1	Control Word (Duplicate)
2	Control Word (Duplicate)
3	Control Word (Duplicate)
4	Digit 0 (rightmost)
5	Digit 1
6	Digit 2
7	Digit 3 (leftmost)

Bit D7 of any of the display digit locations is used to allow an attribute to be assigned to that digit. The attributes are discussed in the next section. If bit D7 is set to a one, that

character will be displayed using the attribute. If bit D7 is cleared, the character will display normally.

CONTROL WORD

When address bit A2 is taken low, the Control Word is accessed. The same Control Word appears in all four of the lower address spaces of the display. Through the Control Word, the display can be cleared, the lamps can be tested, display brightness can be selected, and attributes can be set for any characters which have been loaded with their most significant bit (D7) set high.

Brightness (D0, D1): The state of the lower two bits of the Control Word are used to set the brightness of the entire display, from 0% to 100%. The table below shows the correspondence of these bits to the brightness.

D7	D6	D5	D4	D3	D2	D1	D0	Operation
0	0	X	X	X	X	0	0	Blank
0	0	X	X	X	X	0	1	25% brightness
0	0	X	X	X	X	1	0	50% brightness
0	0	X	X	X	X	1	1	Full brightness

X = don't care

Attributes (D2-D4): Bits D2, D3, and D4 control the visual attributes (i.e., blinking, alternate) of those display digits which have been written with bit D7 set high. In order to use any of the four attributes, the Cursor Enable bit (D4 in the Control Word) must be set. When the Cursor Enable bit is

CONTROL WORD FORMAT

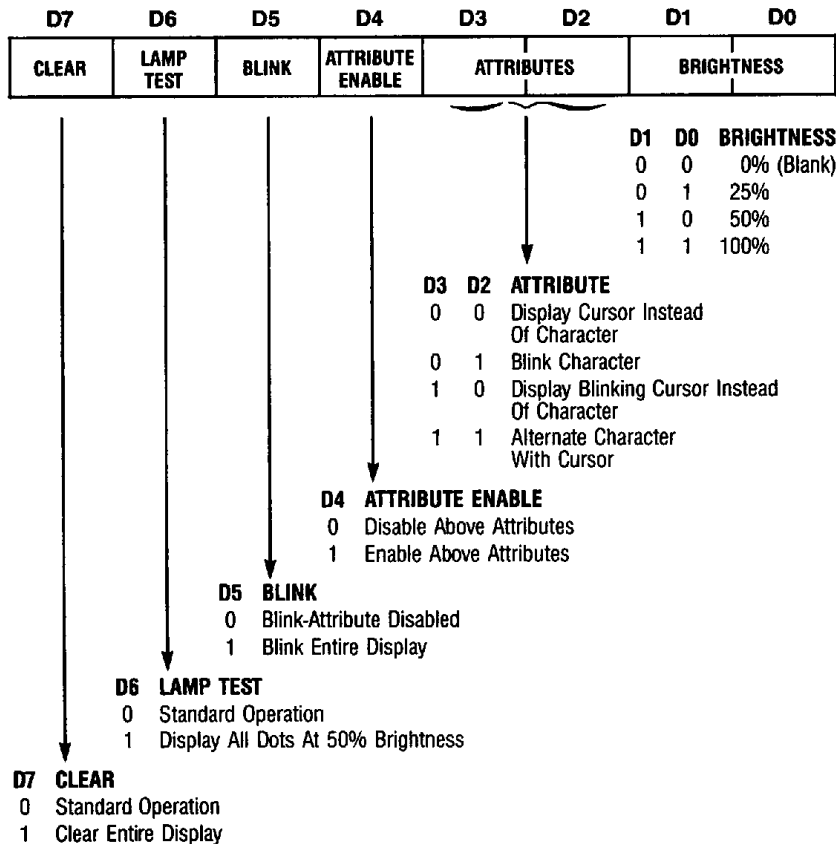

set, and bit D7 in a character location is set, the character will take on one of the following display attributes.

D7	D6	D5	D4	D3	D2	D1	D0	Operation
0	0	0	0	X	X	B	B	Disable highlight attribute
0	0	0	1	0	0	B	B	Display cursor* instead of character
0	0	0	1	0	1	B	B	Blink single character
0	0	0	1	1	0	B	B	Display blinking cursor* instead of character
0	0	0	1	1	1	B	B	Alternate character with cursor*

*"Cursor" refers to a condition when all dots in a single character space are lit to half brightness.
 X = don't care
 B = depends on the selected brightness

Attributes are non-destructive. If a character with bit D7 set is replaced by a cursor (Control Word bit D4 is set, and D3=D2=0) the character will remain in memory and can be revealed again by clearing D4 in the Control Word

Blink (D5): The entire display can be caused to blink at a rate of approximately 2Hz by setting bit D5 in the Control Word. This blinking is independent of the state of D7 in all character locations

In order to synchronize the blink rate in a bank of these devices, it is necessary to tie all devices' clocks and resets together as described in a later section of this data sheet

D7	D6	D5	D4	D3	D2	D1	D0	Operation
0	0	1	X	X	X	B	B	Blinking display

Lamp Test (D6): When the Lamp Test bit is set, all dots in the entire display are lit at half brightness. When this bit is cleared, the display returns to the characters that were showing before the lamp test.

D7	D6	D5	D4	D3	D2	D1	D0	Operation
0	1	0	X	X	X	X	X	Lamp test

Clear Data (7): When D7 is set in the Control Word all character and Control Word memory bits are reset to zero. This causes total erasure of the display, and returns all digits to a non-blink, the preset brightness, non-cursor status.

D7	D6	D5	D4	D3	D2	D1	D0	Operation
1	0	0	0	X	X	%	%	Clear

CASCADING

Cascading the MPD 2545/7/8 is a simple operation. The requirements for cascading are 1) decoding the correct address to determine the chip select for each additional device, 2) assuring that all devices are reset simultaneously, and 3) selecting one display as the clock source and setting all others to accept clock input (the reason for cascading the clock is to synchronize the flashing of multiple displays) One display as a source is capable of driving six other MPD 2545/7/8s. If more displays are required, a buffer will be necessary. The source display must have pin 3 tied high to output clock signals. All other displays must have pin 3 tied low

VOLTAGE TRANSIENTS

It has become common practice to provide 0.01 μ f bypass capacitors liberally in digital systems. Like other CMOS circuitry, the Intelligent Display controller chip has very low power consumption and the usual 0.01 μ f would be adequate were it not for the LEDs. The module itself can, in some conditions, use up to 100 mA (multiplexed). In order to prevent power supply transients, capacitors with low inductance and high capacitance at high frequencies are required. This suggests a solid tantalum or ceramic disc for high frequency bypass. For larger displays, distribute the bypass capacitors evenly, keeping capacitors as close to the power pins as possible. We recommend a 10 μ f and 0.01 μ f for every Intelligent Display to decouple the displays themselves, at the display.

CASCADING THE MPD 2545/7/8

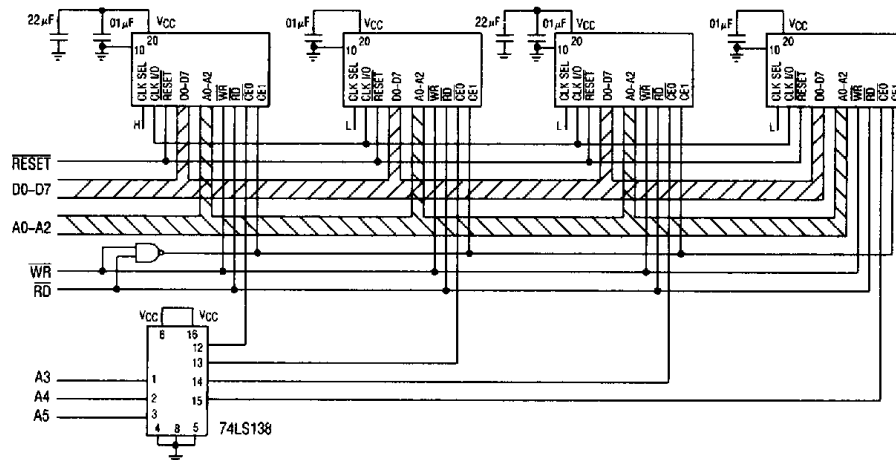

HOW TO LOAD INFORMATION INTO THE MPD 2545/7/8

Information loaded into the MPD 2545/7/8 can be either ASCII data or Control Word data. The following procedure (see also typical loading sequence) will demonstrate a typical loading sequence and the resulting visual display. The word STOP is used in all of the following examples.

- SET BRIGHTNESS**
- Step 1** Set the brightness level of the entire display to your preference (example: 100%)
- LOAD FOUR CHARACTERS**
- Step 2** Load an "S" in the left-hand digit.
Step 3 Load a "T" in the next digit.
Step 4 Load an "O" in the next digit.
Step 5 Load a "P" in the right-hand digit.
- If you loaded the information correctly, the MPD 2545 should now show the word "STOP."
- BLINK A SINGLE CHARACTER**
- Step 6** Into the digit, second from the right, load the hex code "CF," which is the code for an "O" with the D7 bit added as a control bit.
- NOTE: the "O" is the only digit which has the control bit (D7) added to normal ASCII data.
- Step 7** Load enable blinking character into the control word register.
- The MPD 2545 should now display "STOP" with a flashing "O."
- ADD ANOTHER BLINKING CHARACTER**
- Step 8** Into the left hand digit, load the hex code "D3" which is for an "S" with the D7 bit added as a control bit.
- The MPD 2545 should display "STOP" with a flashing "O" and a flashing "S."
- ALTERNATE CHARACTER/CURSORS ENABLE**
- Step 9** Load enable alternate character/cursor into the control word register.
- The MPD 2545 should now display "STOP" with the "O" and the "S" alternating between the letter and a cursor (all dots lit).
- INITIATE FOUR-CHARACTER BLINKING**
 (Regardless of Control Bit setting)
- Step 10** Load enable display blinking.
- The MPD 2545 should now display the entire word "STOP" blinking.

ELECTRICAL AND MECHANICAL CONSIDERATIONS

The CMOS IC of the MPD 2545/7/8 is designed to provide resistance to both Electrostatic and Discharge Damage and Latch Up due to voltage or current surges. Several precautions are strongly recommended for the user, to avoid overstressing these built-in safeguards.

ESD PROTECTION

Users of the MPD 2545/7/8 should be careful to handle the devices consistent with Standard ESD protection procedures. Operators should wear appropriate wrist, ankle or feet ground straps and avoid clothing that collects static charges. Work surfaces, tools and transport carriers that come into contact with unshielded devices or assemblies should also be appropriately grounded.

LATCH UP PROTECTION

Latch up is a condition that occurs in CMOS ICs after the input protection diodes have been broken down. These diodes can be reversed through several means:

$V_{IN} < GND$, $V_{IN} > V_{CC} + 0.5 V$, or through excessive currents begin forced on the inputs. When these situations exist, the IC may develop the response of an SCR and begin conducting as much as one amp through the V_{CC} pin. This destructive condition will persist (latched) until device failure or the device is turned off.

The Voltage Transient Suppression Techniques and buffer interfaces for longer cable runs help considerably to prevent latch conditions from occurring. Additionally, the following Power Up and Power Down sequence should be observed.

POWER UP SEQUENCE

1. Float all active signals by tri-stating the inputs to the displays.
2. Apply V_{CC} and GND to the display.
3. Apply active signals to the displays by enabling all input signals per application.

POWER DOWN SEQUENCE

1. Float all active signals by tri-stating the inputs to the display.
2. Turn off the power to the display.

TYPICAL LOADING SEQUENCE

	CE0	CE1	RD	WR	A2	A1	A0	D7	D6	D5	D4	D3	D2	D1	D0	DISPLAY
1	L	H	H	L	L	X	X	0	0	0	0	0	0	1	1	S
2	L	H	H	L	H	H	H	0	1	0	1	0	0	1	1	ST
3	L	H	H	L	H	H	L	0	1	0	1	0	1	0	0	STO
4	L	H	H	L	H	L	H	0	1	0	0	1	1	1	1	STOP
5	L	H	H	L	H	L	L	0	1	0	1	0	0	0	0	STOP
6	L	H	H	L	H	L	H	1	1	0	0	1	1	1	1	STOP*P
7	L	H	H	L	L	X	X	0	0	0	1	0	1	1	1	STO*P
8	L	H	H	L	H	H	H	1	1	0	1	0	0	1	1	S*TO*P
9	L	H	H	L	L	X	X	0	0	0	1	1	1	1	1	S*TO*P
10	L	H	H	L	L	X	X	0	0	1	0	0	0	1	1	S*T*O*P*

*Blinking Character
 † Character alternating with cursor (all dots lit)

CHARACTER SET

D0	L	H	L	H	L	H	L	H	L	H	L	H	L	H	L	H			
D1	L	L	H	H	L	L	H	H	L	L	H	H	L	L	H	H			
D2	L	L	L	L	H	H	H	H	L	L	L	L	H	H	H	H			
D3	L	L	L	L	L	L	L	L	L	H	H	H	H	H	H	H			
D0D1D2D3	HEX	0	1	2	3	4	5	6	7	8	9	A	B	C	D	E	F		
L	L	L	0	THESE CODES DISPLAY BLANK															
L	L	H	1																
L	H	L	2	!	"	#	\$	%	&	'	()	*	+	,	-	.	/	
L	H	H	3	0	1	2	3	4	5	6	7	8	9	:	;	<	=	>	?
H	L	L	4	a	b	c	d	e	f	g	h	i	j	k	l	m	n	o	
H	L	H	5	p	q	r	s	t	u	v	w	x	y	z	[\]	^	_
H	H	L	6	·	a	b	c	d	e	f	g	h	i	j	k	l	m	n	o
H	H	H	7	p	q	r	s	t	u	v	w	x	y	z	{		}	~	·

Notes 1 A2 must be held high for ASCII data
 2 Bit D7 = 1 enables attributes for the assigned digit

GENERAL QUALITY ASSURANCE LEVELS

The parts are tested in conformance with Quality Level A of MIL-D-87157 for hermetically sealed LED displays with 100% screening. The product is tested to Tables I, II, IIIa and IVa.

Table I. Quality Level A of MIL-D-87157

Test Screen	Method	Conditions
1. Precap Visual	2072 MIL-STD-750	
2. High Temperature Storage	1032 MIL-STD-750	T _{amb} = 125°C, Time = 24 hours
3. Temperature Cycling	1051 MIL-STD-750	Condition B, 10 Cycles, 15 min. Dwell
4. Constant Acceleration	2006 MIL-STD-750	5,000 G's at Y ₁ Orientation
5. Fine Leak	1071 MIL-STD-750	Condition G or H
6. Gross Leak	1071 MIL-STD-750	Condition C
7. Interim Electrical/Optical Tests		Limits and conditions are per the Electrical/Optical Characteristics. The I _{OH} and I _{OL} tests are the inverse of V _{OH} and V _{OL} specified in the Electrical Characteristics T _{amb} = 25°C
8 Burn-In ⁽¹⁾	1015 MIL-STD-883	Condition B at V _{CC} = 5.5 V, T _{amb} = 100°C. t = 160 hours
9. Final Electrical Test		Same as Step 7
10. External Visual	2009 MIL-STD-883	

Note:
 1 MIL-STD 883 test method applies

Intelligent Display Devices

Table II. Group A Electrical Tests - MIL-D-87157

Subgroup/Test	Parameters	LTPD
Subgroup 1 DC Electrical Tests at 25°C	Limits and conditions are per the Electrical/Optical Characteristics. The I _{OH} and I _{OL} tests are the inverse of V _{OH} and V _{OL} specified in the Electrical Characteristics.	5
Subgroup 2 Selected DC Electrical Tests at High Temperatures		7
Subgroup 3 Selected DC Electrical Tests at Low Temperatures		7
Subgroup 4, 5 and 6 Not Applicable		
Subgroup 7 Optical and Functional Tests at 25°C	Satisfied by Subgroup 1	5
Subgroup 8 External Visual		7

Table IIIa. Group B, Class A and B of MIL-D-87157

Subgroup/Test	MIL-STD-750 Method	Conditions	Sample Size
Subgroup 1 Resistance to Solvents	1022		4 Devices/0 Failures
Internal Visual and Mechanical ⁽³⁾	2014		1 Device/0 Failures
Subgroup 2 ^(1) 2) Solderability	2026	T _{amb} = 245°C for 5 seconds	LTPD = 15
Subgroup 3 Thermal Shock (Temp Cycle)	1051	Condition B, 10 Cycles, 15 min Dwell	LTPD = 15
Moisture Resistance	1021		
Fine Leak	1071	Condition G or H	
Gross Leak	1071	Condition C	
Electrical/Optical Endpoints		Limits and conditions are per the Electrical/Optical Characteristics. The I _{OH} and I _{OL} tests are the inverse of V _{OH} and V _{OL} specified in the Electrical Characteristics. T _{amb} = 25°C	
Subgroup 4 ⁽¹⁾ Operating Life Test (340 hours)	1027	T _{amb} = 100°C @ V _{CC} = 5.5 V	LTPD = 10
Electrical/Optical Endpoints		Same as Subgroup 3	
Subgroup 5 Non-Operating (Storage) Life Test (340 hours)	1032	T _{amb} = +125°C	LTPD = 10
Electrical/Optical Endpoints		Same as Subgroup 3	

Notes:

- 1. Whenever electrical/optical tests are not required as endpoints, electrical rejects may be used
- 2. The LTPD applies to the number of leads inspected except in no case shall less than 3 displays be used to provide the number of leads required
- 3. MIL-STD-883 test methods apply
- 4. Visual requirements shall be as specified in MIL-STD-883 Methods 1010 or 1011

Table IVa. Group C, Class A and B of MIL-D-87157

Subgroup/Test	MIL-STD-750 Method	Conditions	Sample Size
Subgroup 1 Physical Dimensions	2066		2 Devices/0 Failures
Subgroup 2 ^(2 6) Lead Integrity	2004	Condition B2	LTPD = 15
Fine Leak	1071	Condition G or H	
Gross Leak	1071	Condition C	
Subgroup 3 Shock	2016	1500G, Time = 0.5 ms, 5 Blows in Each Orientation X1, Y1, Y2	LTPD = 15
Vibration, Variable Frequency	2056		
Constant Acceleration	2006	5,000G at Y1 Orientation	
External Visual ⁽⁴⁾	1001 or 1011		
Electrical/Optical Endpoints		Limits and conditions are per the Electrical/Optical Characteristics. The I _{OH} and I _{OL} tests are the inverse of V _{OH} and V _{OL} specified in the Electrical Characteristics. T _{amb} = 25°C.	
Subgroup 4 ^(1 3) Salt Atmosphere	1041		LTPD = 15
External Visual ⁽⁴⁾	1010 or 1011		
Subgroup 5 Bond Strength ⁽⁵⁾	2037	Condition A	LTPD = 20 (C=0)
Subgroup 6 Operating Life Test ⁽⁷⁾	1026	T _{amb} = 100°C @ V _{CC} = 5.5 V	λ = 10
Electrical/Optical Endpoints ⁽⁷⁾	1026	Same as Subgroup 3	

Notes:

- | | |
|---|---|
| <p>1 Whenever electrical/optical tests are not required as endpoints, electrical rejects may be used</p> <p>2 The LTPD applies to the number of leads inspected except in no case shall less than three displays be used to provide the number of leads required</p> <p>3 Solderability samples shall not be used</p> | <p>4 Visual requirements shall be as specified in MIL-STD 883, Methods 1010 or 1011</p> <p>5 Displays may be selected prior to seal</p> <p>6 MIL STD 883 test method applies</p> <p>7 Test method or conditions in accordance with detail specification</p> |
|---|---|