

**OEM Wireless Local Area Network PC Card**



The Intersil OEM WLAN PC Card (Note 1) is a complete wireless high speed modem utilizing the Intersil PRISM™ Direct Sequence Spread Spectrum Wireless Transceiver chip set. This card

is made available to OEM's (Original Equipment Manufacturers) intending to private label or integrate the product. It provides a sophisticated turnkey solution of hardware and software to system providers or integrators requiring wireless data communications capability and is ideal for integration into computer platforms.

Supporting the IEEE 802.11 network specification for Direct Sequence Spread Spectrum DSSS signaling, the card is packaged in a PCMCIA Type II extended cover set and sold in standard packs of 50 units. Radio design evaluation can be conducted by using PRISM1KIT-EVAL (PCMCIA card with an open cover set and connector output, two cards per kit) or WLANKITPR1-EVAL (PCMCIA card with cover set and integrated antenna, 2 cards per kit). The card provides data rates up to 2Mbps. Outdoor line of sight range in excess of 1000 feet has been demonstrated and indoor range of 300 feet, depending on environment, is achievable. Interoperable Access Points are available from a number of suppliers, enabling a total wireless network solution.

**NOTES:**

1. Throughout this document, all references to 'PC Card', 'WLAN adapter', 'adapter', or 'card' refer to a covered card assembly conforming to the mechanical size specifications of the PCMCIA Standard Release 2.0, Type II Extended (5.0mm) definition.
2. The range will vary in different operating environments due to effects such as building construction.

**Features**

- FCC Certified Under Part 15 to Operate in 2.4GHz ISM Band
- Support for 1 and 2 Megabit Per Second (Mbps) Data Rates
- Supports the IEEE802.11 Direct Sequence Specification
- Microsoft® Windows® 95 NDIS3 and Microsoft Windows 3.1 NDIS2 Network Drivers Available (ODI Network Drivers Planned)
- Integrated Microstrip Antenna
- Microcode/BIOS are Contained in Programmable Nonvolatile Flash Memory
- Radio Range of 300 Feet in an Indoor Environment (Note 2)
- Completely Covered Assembly is Designed to Fully Support PCMCIA's Defined Mechanical and Environmental Stress Conditions
- Intelligent Power Control, Including Low Power Standby Mode

**Ordering Information**

PART NUMBER	DESCRIPTION	CARDS PER SET
PRISM1BRDA	OEM WLAN PC CARD	50
WLANKITPR1-EVAL	WLAN EVALUATION KIT	2

**Packaging**

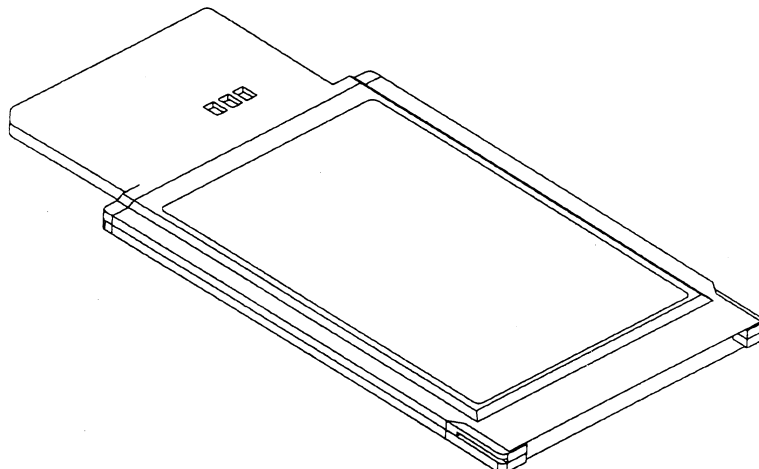

PRISM and Design® is a registered trademark of Intersil Corporation. PRISM™ is a trademark of Intersil Corporation.

## Functional Overview

The WLAN PC Card is designed to operate in the 2.4GHz ISM frequency band, channels 1 to 11, as specified by the FCC in the USA and ETSI in Europe (refer to Table 3). The Card will also operate with reduced performance (due to filter selection) on channel 14, specified for use in Japan. Radio Transmitters must be certified in a country prior to use. Refer to Table 4 for a list of countries and agencies that have approved the PRISM1BRDA for operation.

The Intersil PRISM Chip Set and AMD PCNet Mobile allows for high level integration allowing for reduced size, increased throughput, improved radio performance and faster time to market. The WLAN PC card implements Direct Sequence Spread Spectrum DSSS technology providing superior noise and signal jamming immunity including less severe impact from unintentional radiators such as microwave ovens. The user can connect the PC Card in an ad-hoc, peer-to-peer networking scheme, allowing for instant network setup in any office environment. By using an access point, the wireless LAN can be set up to allow for a greater number of users to interconnect, and to increase the coverage area. With a portal, the wireless LAN can be easily connected into an existing wired LAN, allowing for easy expansion of the service.

To learn more about what the IEEE802.11 is, refer to:

- Tech Brief TB337 "A Brief Tutorial on Spread Spectrum and Packet Radio" [1].

For a more detailed description of radio operation, please refer to:

- Data sheet "PRISM 2.4GHz Chip Set" [2] and:
- Application Note AN9624 "PRISM1KIT-EVAL DSSS PC Card Wireless LAN Description" [3].

For more specific software questions, refer to:

- Application Note AN9666 "Wireless LAN Evaluation Kit SW Installation and Usage" [4].

## The MAC Protocol Handler (AMD® PCNet™ Mobile) (AM79C930)

The PCNetMobile device (AM79C930) and its firmware are responsible for running the 802.11 protocol in the WLAN card. This section describes the features of IEEE 802.11 that are implemented. Further information can be obtained from the following documents:

1. AMD PCNetMobile WLAN Controller, Firmware Overview (available from AMD)
2. Firmware Interface Specification for IEEE 802.11/D5 (available from AMD)

Contact AMD's web site:

<http://www.amd.com/products/npd/npd.html>  
 select \* Available Literature  
 or \* PCnet Family Drivers

The functions supported by the STA (station) Firmware are:

- DCF (Distributed Coordination Function)
- CSMA/CA (Carrier Sense Multiple Access with Collision Avoidance)

- Random Backoff
- RTS/CTS Handshake (Ready To Send/Clear To Send) and NAV Management (Network Allocation Vector)
- MAC Level Acknowledgments (Media Access Control)
- Re-Transmission of Unacknowledged Frames
- Duplicate Detection and Rejection
- Broadcast and Multicast Frames
- Fragmentation and Re-Assembly
- Power Management (Planned)
- Timestamp Synchronization
- Probe Generation
- Beacon Generation in an Ad-Hoc Network
- Probe Response Generation in an Ad-Hoc Network

## Card Information Structure

The standard Intersil WLAN PC Card will be supplied with the following information embedded in the CIS. It should be noted that in most systems this information is displayed when the card is inserted. Customization of the CIS for specific customer requirements is available upon request, to enable customer information to be displayed when the card is inserted.

TABLE 1.

FUNCTION NAME	CONTENT
Manufacturer's ID	00
Function ID	Network Adapter
Product Revision	5
Manufacturer	AMD
Product	AM79C930
PROG	
LOT	

## Network Driver Software

The Intersil OEM WLAN PC Card will be supplied with NDIS2, NDIS3 and ODI network drivers. These drivers will be tested with the following network operating systems:

TABLE 2. SOFTWARE COMPATIBILITY TESTING

MANUFACTURER	TITLE	VERSION	DRIVER
Microsoft	Windows for Work Groups	3.11	NDIS2
Microsoft	Windows 95		NDIS3
Microsoft	Windows NT		NDIS3
Novel	Netware		ODI
IBM	OS2		ODI

Contact the factory for latest software status or visit our PRISM web site: <http://www.intersil.com>

### IEEE 802.11 International Agreement and Frequency Assignments

The IEEE802 LAN committee has forged an international agreement providing for wireless data communication standards for the frequency range of 2.4GHz to 2.4853GHz, as allocated by the FCC in the USA, and in the 2.471GHz to 2.497GHz frequency range, as specified by the regulatory authority in Japan. These standards are designed to focus the industry to develop highly integrated, low cost, interoperable WLAN equipment, of which PRISM1BRDA is a prime example.

There are 11 channels specified by the FCC in the 2.4GHz to 2.4853GHz range, and one channel in the 2.471GHz to 2.497GHz range, for operation in Japan. The ETSI (European) regulatory body conforms to the USA (FCC) channel assignments with the exceptions of channels 1 and 2 as shown in Table 3.

The available channels of operation in the 2.4GHz to 2.4853GHz and 2.471GHz to 2.497GHz ranges are as follows:

TABLE 3.

CHANNEL ID	FCC CHANNEL FREQUENCIES	ETSI CHANNEL FREQUENCIES	JAPAN FREQUENCY
1	2412MHz	N/A	N/A
2	2417MHz	N/A	N/A
3	2422MHz	2422MHz	N/A
4	2427MHz	2427MHz	N/A
5	2432MHz	2432MHz	N/A
6	2437MHz	2437MHz	N/A
7	2442MHz	2442MHz	N/A
8	2447MHz	2447MHz	N/A
9	2452MHz	2452MHz	N/A
10	2457MHz	2457MHz	N/A
11	2462MHz	2462MHz	N/A
12	N/A	2467MHz	N/A
13	N/A	2472MHz	N/A
14	N/A	N/A	2484MHz

### Warranty

The Intersil WLAN PC Card product is covered by a one year manufacturing warranty. Operation of the WLAN PC Card outside of the maximum ratings detailed above will make the warranty void.

### Agency and Regulatory Body Approvals

The WLAN PC Card will comply to the following standards:

TABLE 4.

COUNTRY	APPROVAL	NOTES
USA (Note 3)	FCC part 15, Sec. 15.247, Sec. 15.107 and 15.109	Approved for Intentional Radiators Computer Peripheral
Canada (Note 4)	ICAN RSS-210	Approved
Europe	ETSI 300.328 Nov 96 EMC prETS 300.826	Planned

NOTES:

- The Intersil FCC Identification Number is: MRF13316C2
- The IC Approval Number is: CAN2722102478

# PRISM1BRDA

## Absolute Maximum Ratings

Supply Voltage . . . . . -0.3V to 6.0V (Max)  
 Storage Temperature (Note 5) . . . . . -20°C to 65°C

## Operating Conditions

Temperature Range . . . . .  $0^{\circ}\text{C} \leq T_A \leq 55^{\circ}\text{C}$   
 Supply Voltage Range . . . . . 4.75V to 5.25V

**NOTE:**

5. All temperature references refer to ambient conditions.

*Caution: These are the absolute maximum ratings for the PC Card product. Exceeding these limits could cause permanent damage to the card.*

**Electrical Specifications** Test conditions supply voltage: 5V  $\pm$ 5%,  $T_A = 25^{\circ}\text{C}$

PARAMETER	SYMBOL	CONDITIONS	MIN	TYP	MAX	UNITS
<b>CURRENT CONSUMPTION</b>						
Average Current (Without Power Saving Mode) (Note 6)	$I_{CC}$	2% Transmit 98% Receive	-	290	-	mA
Average Current (With Power Saving Mode) (Note 6)	$I_{CC}$	2% TX 90% Standby 8% RX	-	60	-	mA
Continuous Transmit Mode	$I_{CC}$		-	488	-	mA
Continuous Receive Mode	$I_{CC}$		-	287	-	mA
Standby (Note 6)	$I_{CC}$	Estimated	-	30	-	mA
<b>PC CARD LOGIC LEVELS</b>						
Input HIGH Voltage	$V_{IH}$		2.4	-	$V_{CC} + 0.2$	V
Input LOW Voltage	$V_{IL}$		0.0	-	0.8	V
Output HIGH Voltage	$V_{OH}$	-0.4mA ILOAD	2.8	-	$V_{CC}$	V
Output LOW Voltage	$V_{OL}$	4mA ILOAD	-	-	0.45	V
		12mA ILOAD	-	-	0.45	V
		24mA ILOAD	-	-	0.45	V
<b>PC CARD LEAKAGE CURRENT</b>						
Input Leakage Current	$I_{IN}$		-10	-	10	$\mu\text{A}$
<b>PC CARD LOADING CAPACITANCE</b>						
Input Capacitance	$C_{IN}$		-	-	12	pF
Output Capacitance	$C_{OUT}$		-	-	12	pF
<b>ENVIRONMENTAL SPECIFICATIONS</b>						
Vibration	Vib	10Hz to 2000Hz, $V_{CC} = 0$	-	-	15	G
Drop	Drop		-	-	75	cm
Torque	T	$10^0$ Max	-	-	11	Lb/Ft <sup>2</sup>
ESD	ESD	Non-Operating	-	-	1500	V
X-RAY	X-RAY		-	-	10K	Roentgen
UV	UV	Wavelength 254nm	-	-	15K	$\mu\text{W}/\text{cm}$
Humidity	RH		-	-	98	%
EMI	EMI		-	-	1K	Oersted

## PRISM1BRDA

### Electrical Specifications Test conditions supply voltage: 5V ±5%, T<sub>A</sub> = 25°C (Continued)

PARAMETER	SYMBOL	CONDITIONS	MIN	TYP	MAX	UNITS
<b>RF SYSTEM SPECIFICATION</b>						
Antenna Gain	AG	Max	-	2.5	-	dBi
EIRP	EIRP		-	20	-	dBm
Receive Sensitivity	RX_S	8% PER, 2mB/s	-	-88	-	dBm
Maximum Receive Level	RX_MAX	PER <8%	-	-4	-	dBm
Third Order Intercept Point (Input)	IIP3		-	-24	-	dBm
Image Rejection	IR	PER <8%	-	65	-	dB
IF Rejection	IFR	PER <8%	-	80	-	dB
Adjacent Channel Rejection	ACPR	PER <8% (Note 7)	-	63	-	(dB)
Noise Figure RF Front End	NF		-	8	-	dB
Data Rate (Physical Layer)	Rate		-	1 and 2	-	Mb/s
Data Rate (PC to PC)	THRGH	DQPSK 2Mb mode	-	1.2	-	Mb/s

**NOTES:**

6. Refer to Application Note "PRISM Power Management Modes" AN9665.
7. The adjacent channel measurement is carried out on two channels specially separated by 25MHz (5 channels).

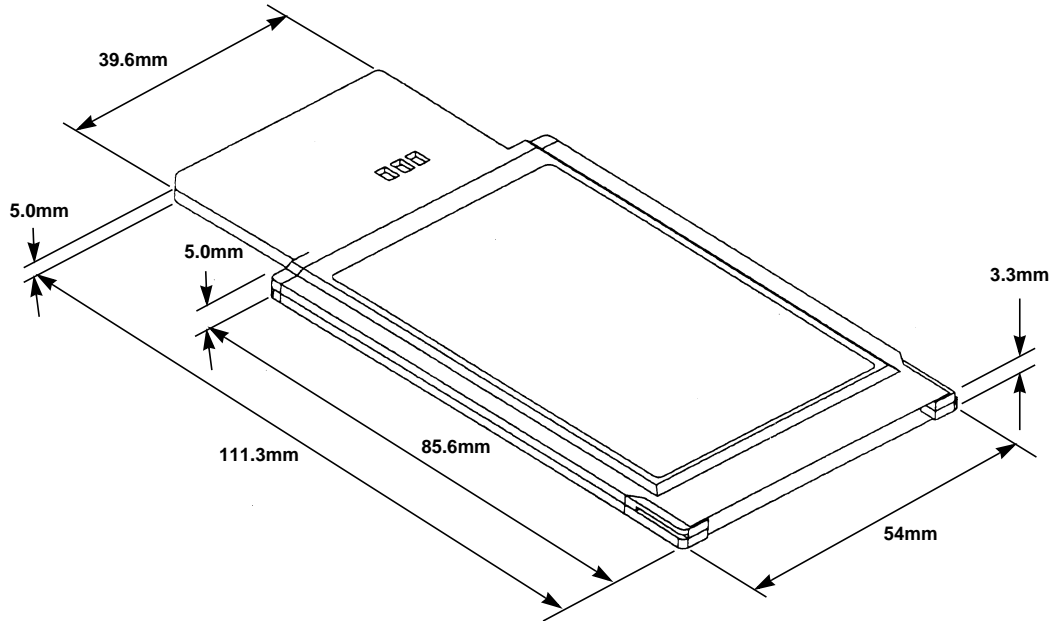

FIGURE 1. DIMENSIONED MECHANICAL DRAWING OF COVERSET

### PC Card Labels

The PC Card is offered with generic back label as shown below. Custom label options are available.

#### Back PC Card Label



### References

For Intersil documents available on the internet, see web site <http://www.intersil.com/>  
Intersil AnswerFAX (407) 724-7800.

Further information can be found in the following documents:

- The PCNetMobile (AM79C930) data sheet.
- Intersil PRISM data sheets, web home page, <http://www.intersil.com/>
- IEEE 802.11 Standards Project (available from the IEEE, New York, USA).
- PC Card V2.1 Standard

All Intersil semiconductor products are manufactured, assembled and tested under **ISO9000** quality systems certification.

*Intersil semiconductor products are sold by description only. Intersil Corporation reserves the right to make changes in circuit design and/or specifications at any time without notice. Accordingly, the reader is cautioned to verify that data sheets are current before placing orders. Information furnished by Intersil is believed to be accurate and reliable. However, no responsibility is assumed by Intersil or its subsidiaries for its use; nor for any infringements of patents or other rights of third parties which may result from its use. No license is granted by implication or otherwise under any patent or patent rights of Intersil or its subsidiaries.*

For information regarding Intersil Corporation and its products, see web site <http://www.intersil.com>

### **Sales Office Headquarters**

#### **NORTH AMERICA**

Intersil Corporation  
P. O. Box 883, Mail Stop 53-204  
Melbourne, FL 32902  
TEL: (407) 724-7000  
FAX: (407) 724-7240

#### **EUROPE**

Intersil SA  
Mercure Center  
100, Rue de la Fusee  
1130 Brussels, Belgium  
TEL: (32) 2.724.2111  
FAX: (32) 2.724.22.05

#### **ASIA**

Intersil (Taiwan) Ltd.  
7F-6, No. 101 Fu Hsing North Road  
Taipei, Taiwan  
Republic of China  
TEL: (886) 2 2716 9310  
FAX: (886) 2 2715 3029