

PWM Power Control with Interference Suppression

Description

The U6083B is a PWM IC in bipolar technology for the control of an N-channel power MOSFET used as a high-side switch. The IC is ideal for use in the brightness

control (dimming) of lamps e.g., in dashboard applications.

Features

- Pulse-width modulation up to 2 kHz clock frequency
- Protection against short circuit, load dump over-voltage and reverse V_S
- Duty cycle 18 to 100% continuously
- Internally reduced pulse slope of lamp's voltage
- Interference and damage protection according to VDE 0839 and ISO/TR 7637/1.
- Charge-pump noise suppressed
- Ground-wire breakage protection

Block Diagram

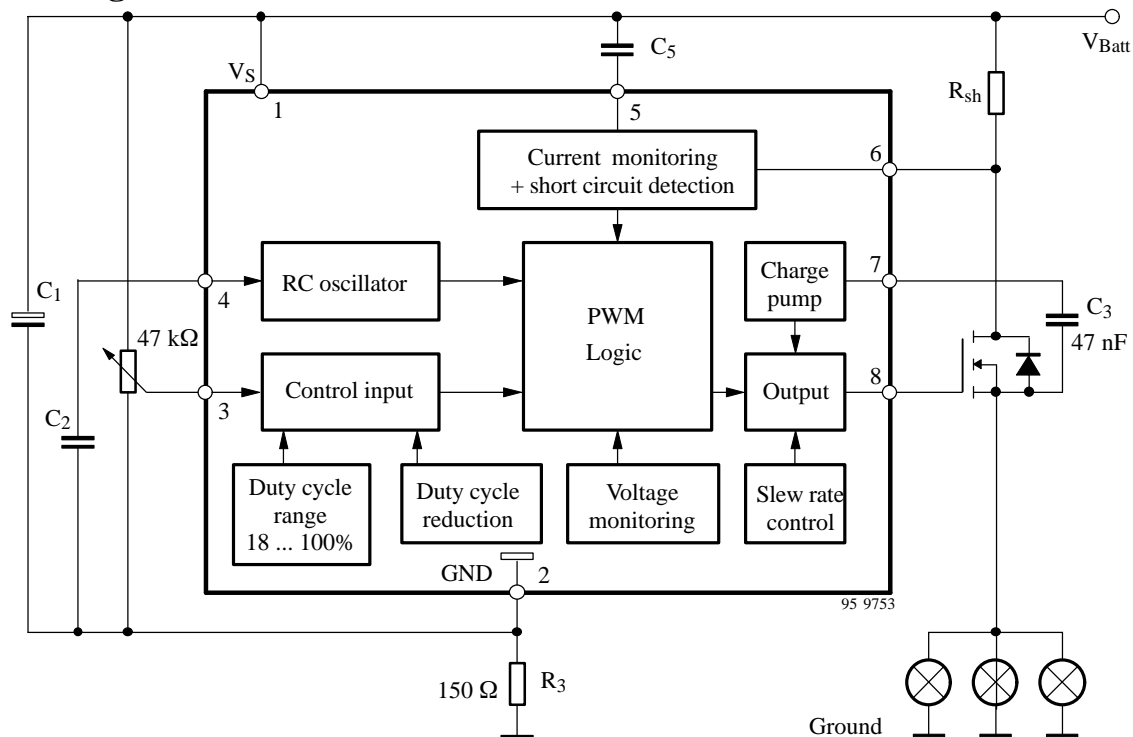
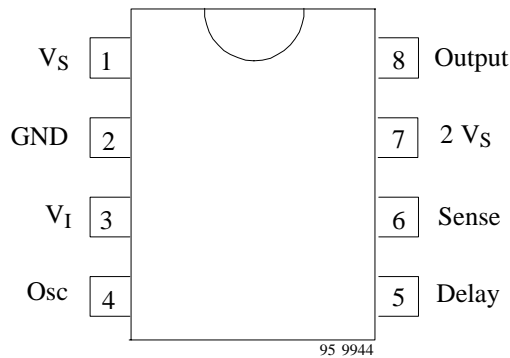

Figure 1. Block diagram with external circuit

Ordering Information

Extended Type Number	Package	Remarks
U6083B	DIP8	

Pin Description



Pin	Symbol	Function
1	V _S	Supply voltage V _S
2	GND	IC ground
3	V _I	Control input (duty cycle)
4	Osc	Oscillator
5	Delay	Short circuit protection delay
6	Sense	Current sensing
7	2 V _S	Voltage doubler
8	Output	Output

Functional Description

Pin 1, Supply Voltage, V_S or V_{Batt}

Overvoltage Detection

Stage 1:

If overvoltages V_{Batt} > 20 V (typ.) occur, the external transistor is switched off and switched on again at V_{Batt} < 18.5 V (hysteresis).

Stage 2:

If V_{Batt} > 28.5 V (typ), the voltage limitation of the IC is reduced from V_S = 26 V to 20 V. The gate of the external transistor remains at the potential of the IC ground, thus producing voltage sharing between FET and lamps in the event of overvoltage pulses occurring (e.g., load dump). The short-circuit protection is not in operation. At V_{Batt} approx. < 23 V, the overvoltage detection stage 2 is switched off. Thus during overvoltage detection stage 2 the lamp voltage V_{lamp} is calculated to :

$$V_{Lamp} = V_{Batt} - V_S - V_{GS}$$

V_S = Supply voltage of the IC at overvoltage detection stage 2

V_{GS} = Gate – source voltage of the FET

Undervoltage Detection

In the event of voltages of approximately V_{Batt} < 5.0 V, the external FET is switched off and the latch for short-circuit detection is reset.

A hysteresis ensures that the FET is switched on again at approximately V_{Batt} ≥ 5.4 V.

Pin 2, GND

Ground-Wire Breakage

To protect the FET in the case of ground-wire breakage, a 1 MΩ resistor between gate and source it is recommended to provide proper switch-off conditions.

Pin 3, Control Input

The pulse width is controlled by means of an external potentiometer (47 kΩ). The characteristic (angle of rotation/duty cycle) is linear. The duty cycle can be varied from 18 to 100%. It is possible to further restrict the duty cycle with the resistors R₁ and R₂ (see figure 3).

In order to reduce the power dissipation of the FET and to increase the lifetime of the lamps, the IC automatically reduces the maximum duty cycle at Pin 8 if the supply voltage exceeds V₂ = 13 V. Pin 3 is protected against short-circuit to V_{Batt} and ground (V_{Batt} ≤ 16.5 V).

Pin 4, Oscillator

The oscillator determines the frequency of the output voltage. This is defined by an external capacitor, C₂. It is charged with a constant current, I, until the upper switching threshold is reached. A second current source is then activated which taps a double current, 2 × I, from the charging current. The capacitor, C₂, is thus discharged at the current, I, until the lower switching threshold is reached. The second source is then switched off again and the procedure starts once more.

Example for Oscillator Frequency Calculation:

Switching thresholds

V_{T100} = High switching threshold (100% duty cycle)

$$V_{T100} = V_S \times \alpha_1 = (V_{Batt} - I_S \times R_3) \times \alpha_1$$

V_{T<100} = High switching threshold (< 100% duty cycle)

$$V_{T<100} = V_S \times \alpha_2 = (V_{Batt} - I_S \times R_3) \times \alpha_2$$

V_{TL} = Low switching threshold

$$V_{TL} = V_S \times \alpha_3 = (V_{Batt} - I_S \times R_3) \times \alpha_3$$

whereas

α₁, α₂ and α₃ are fixed values.

Calculation Example

The above mentioned threshold voltages are calculated for the following values given in the data sheet.

$$V_{Batt} = 12 \text{ V}, I_S = 4 \text{ mA}, R_3 = 150 \Omega, \\ \alpha_1 = 0.7, \alpha_2 = 0.67 \text{ and } \alpha_3 = 0.28.$$

$$V_{T100} = (12 \text{ V} - 4 \text{ mA} \times 150 \Omega) \times 0.7 \approx 8 \text{ V}$$

$$V_{T<100} = 11.4 \text{ V} \times 0.67 = 7.6 \text{ V}$$

$$V_{TL} = 11.4 \text{ V} \times 0.28 = 3.2 \text{ V}$$

Oscillator Frequency

3 cases have to be distinguished

- 1) f_1 for duty cycle = 100%, no slope reduction with capacitor C_4 (see figure 3)

$$f_1 = \frac{I_{osc}}{2 \times (V_{T100} - V_{TL}) \times C_2}, \text{ where } C_2 = 68 \text{ nF} \\ I_{osc} = 45 \mu\text{A}$$

$$f_1 = \dots = 75 \text{ Hz}$$

- 2) f_2 for duty cycle < 100%, no slope reduction with capacitor C_4

For a duty cycle of less than 100%, the oscillator frequency, f , is as follows:

$$f_2 = \frac{I_{osc}}{2 \times (V_{T<100} - V_{TL}) \times C_2}, \text{ where } C_2 = 68 \text{ nF} \\ I_{osc} = 45 \mu\text{A}$$

$$f_2 = \dots = 69 \text{ Hz}$$

- 3) f_3 with duty cycle < 100% with slope reduction capacitor C_4 (see page 3 "Output Slope Control")

$$f_3 = \frac{I_{osc}}{2 \times (V_{T<100} - V_{TL}) \times C_2 + 2V_{Batt} \times C_4}$$

where $C_2 = 68 \text{ nF}$

$$C_4 = 1.8 \text{ nF}$$

$$I_{osc} = 45 \mu\text{A}$$

$$f_3 = \dots = 70 \text{ Hz}$$

By selecting different values of C_2 and C_4 , it is possible to have a range of oscillator frequencies from 10 to 2000 Hz as shown in the data sheet.

Output Slope Control

The slope of the lamp voltage is internally limited to reduce radio interference by limitation of the voltage gain of the PWM comparator.

Thus, the voltage rise on the lamp is proportional to the oscillator voltage increase at the switchover time according to the equation.

$$dV_8/dt = \alpha_4 \times dV_4/dt =$$

$$2 \times \alpha_4 \times f \times (\alpha_2 - \alpha_3) \times (V_{Batt} - I_S \times R_3)$$

when

$$f = 75 \text{ Hz}, V_{TX} = V_{T<100} \text{ and } \alpha_4 = 63$$

we obtain

$$dV_8/dt = 2 \times 63 \times 75 \text{ Hz} \times (0.67 - 0.28) \times (12 \text{ V} - 4 \text{ mA} \times 150 \Omega) \\ = 42 \text{ V/ms}$$

Via an external capacitor, C_4 , the slope can be further reduced as follows:

$$dV_8/dt = I_{OSC}/(C_4 + C_2/\alpha_4)$$

when

$$I_{OSC} = 45 \mu\text{A}, C_4 = 1.8 \text{ nF}, C_2 = 68 \text{ nF} \text{ and } \alpha_4 = 63$$

$$\text{then } dV_8/dt = 45 \mu\text{A}/(1.8 \text{ nF} + 68 \text{ nF}/63) = 15.6 \text{ V/ms}$$

To damp oscillation tendencies, a resistance of 100 Ω in series with capacitance C_4 is recommended.

Interference Suppression

"On-board" radio reception according to VDE 0879 part 3/4.81

Test conditions referring to figure 2.

Application circuit according to figure 1 or 3.

Load: nine 4-W lamps in parallel.

Duty cycle = 18%

V_{Batt} = 12 V

f_{Osc} = 100 Hz

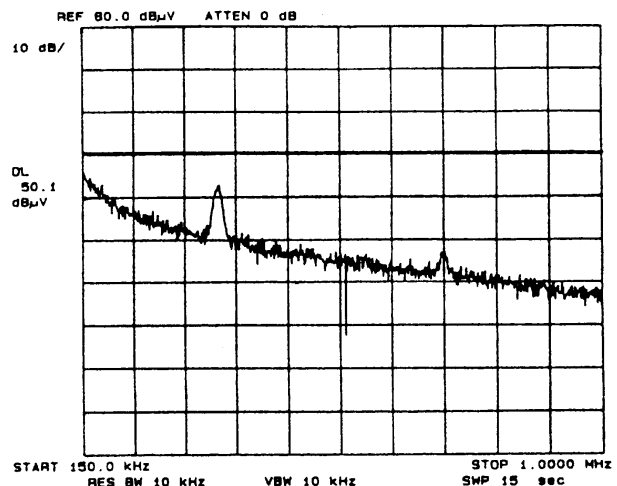

Figure 2. Voltage spectrum of on-board radio reception

Pins 5 and Pin 6, Short-Circuit Protection and Current Sensing

1. Short-Circuit Detection and Time Delay, t_d

The lamp current is monitored by means of an external shunt resistor. If the lamp current exceeds the threshold for the short-circuit detection circuit ($V_{T2} \approx 90$ mV), the duty cycle is switched over to 100% and the capacitor C_5 is charged by a current source of $I_{ch} - I_{dis}$. The external FET is switched off after the cut-off threshold (V_{T5}) is reached. Renewed switching on of the FET is possible only after a power-on reset. The current source, I_{dis} , ensures that the capacitor C_5 is not charged by parasitic currents.

Time delay, t_d , is as follows:

$$t_d = C_5 \times V_{T5} / (I_{ch} - I_{dis})$$

With $C_5 = 100$ nF and $V_{T5} = 10.4$ V, $I_{ch} = 13$ μ A, $I_{dis} = 3$ μ A, we have

$$t_d = 100 \text{ nF} \times 10.4 \text{ V} / (13 \text{ } \mu\text{A} - 3 \text{ } \mu\text{A})$$

$$t_d = 104 \text{ ms}$$

2. Current Limitation:

The lamp current is limited by a control amplifier to protect the external power transistor. The voltage drop across an external shunt resistor acts as the measured variable. Current limitation takes place for a voltage drop of $V_{T1} \approx 100$ mV. Owing to the difference $V_{T1} - V_{T2} \approx 10$ mV, it is ensured that current limitation occurs only when the short-circuit detection circuit has responded.

After a power-on reset, the output is inactive for half an oscillator cycle. During this time, the supply voltage capacitor can be charged so that current limitation is guaranteed in the event of a short-circuit when the IC is switched on for the first time.

Pins 7 and 8, Charge Pump and Output,

Pin 8 (output) is suitable for controlling a power MOSFET. During the active integration phase, the supply current of the operational amplifier is mainly supplied by the capacitor C_3 (bootstrapping). In addition, a trickle charge is generated by an integrated oscillator ($f_7 \approx 400$ kHz) and a voltage doubler circuit. This permits a gate voltage supply at a duty cycle of 100%.

Absolute Maximum Ratings

Parameters	Symbol	Value	Unit
Junction temperature	T_j	150	$^{\circ}\text{C}$
Ambient temperature range	T_{amb}	-40 to +110	$^{\circ}\text{C}$
Storage temperature range	T_{stg}	-55 to +125	$^{\circ}\text{C}$

Thermal Resistance

Parameters	Symbol	Value	Unit
Junction ambient	R_{thJA}	120	K/W

Electrical Characteristics

$T_{amb} = -40$ to $+110^{\circ}\text{C}$, $V_{Batt} = 9$ to 16.5 V, (basic function is guaranteed between 6.0 V to 9.0 V) reference point ground, unless otherwise specified (see figure 1). All other values refer to Pin GND (Pin 2).

Parameters	Test Conditions / Pins	Symbol	Min.	Typ.	Max.	Unit
Current consumption	Pin 1	I_S			7.9	mA
Supply voltage	Overvoltage detection, stage 1	V_{Batt}			25	V
Stabilized voltage	$I_S = 10$ mA Pin 1	V_S	24.5		27.0	V
Battery undervoltage detection	– on	V_{Batt}	4.4	5.0	5.6	V
	– off		4.8	5.4	6.0	
Battery overvoltage detection						
Stage 1:	– on	V_{Batt}	18.3	20.0	21.7	V
	– off		16.7	18.5	20.3	
Stage 2: Detection stage 2	– on	V_{Batt}	25.5	28.5	32.5	V
	– off		19.5	23.0	26.5	
Stabilized voltage	$I_S = 30$ mA Pin 1	V_S	18.5	20.0	21.5	V
Short-circuit protection Pin 6						
Short-circuit current limitation	$V_{T1} = V_S - V_6$	V_{T1}	85	100	120	mV
Short-circuit detection	$V_{T2} = V_S - V_6$	V_{T2}	75	90	105	mV
		$V_{T1} - V_{T2}$	3	10	30	
Delay timer short circuit detection, $V_{Batt} = 12$ V Pin 5						
Switched off threshold	$V_{T5} = V_S - V_5$	V_{T5}	10.2	10.4	10.6	V
Charge current		I_{ch}		13		μA
Discharge current		I_{dis}		3		μA
Capacitance current	$I_5 = I_{ch} - I_{dis}$	I_5	5	10	15	mA
Voltage doubler Pin 7						
Voltage	Duty cycle 100%	V_7	$2 V_S$			
Oscillator frequency		f_7	280	400	520	kHz
Internal voltage limitation	$I_7 = 5$ mA (whichever is lower)	V_7	26	27.5	30.0	V
			V_{S+14}	V_{S+15}	V_{S+16}	
Edge steepness	$dv_8/dt = \alpha_4 dv_4/dt$ dV_8/dt_{max}	α_4	53	63	72 130	V/ms

*) Reference point is battery ground.

Electrical Characteristics (continued)

$T_{amb} = -40$ to $+110^{\circ}\text{C}$, $V_{Batt} = 9$ to 16.5 V, (basic function is guaranteed between 6.0 V to 9.0 V) reference point ground, unless otherwise specified (see figure 1). All other values refer to Pin GND (Pin 2).

Parameters	Test Conditions / Pins	Symbol	Min.	Typ.	Max.	Unit
Gate output Pin 8						
Voltage	Low level	V_8	0.35	0.70	0.95	V
	$V_{Batt} = 16.5$ V $T_{amb} = 110^{\circ}\text{C}$, $R_3 = 150 \Omega$				1.5 *)	
	High level, duty cycle 100%	V_8		V_7		
Current	$V_8 =$ Low level	I_8	1.0			mA
	$V_8 =$ High level, $I_7 > I_8 $		-1.0			
Duty cycle	Min: $C_2 = 68$ nF Max: $V_{Batt} \leq 12.4$ V $V_{Batt} = 16.5$ V, $C_2 = 68$ nF	t_p/T	15 100 65	18 73	21 81	%
Oscillator						
Frequency	Pin4	f	10		2000	Hz
Threshold cycle Upper	$V_8 =$ High, $\alpha_1 = \frac{V_{T100}}{V_S}$	α_1	0.68	0.7	0.72	
	$V_8 =$ Low, $\alpha_2 = \frac{V_{T<100}}{V_S}$	α_2	0.65	0.67	0.69	
	$\alpha_3 = \frac{V_{TL}}{V_S}$	α_3	0.26	0.28	0.3	
Oscillator current	$V_{Batt} = 12$ V	$\pm I_{Osc}$	34	45	54	μA
Frequency	C_4 open, $C_2 = 68$ nF duty cycle = 50%	f	56	75	90	Hz

*) Reference point is battery ground.

Application

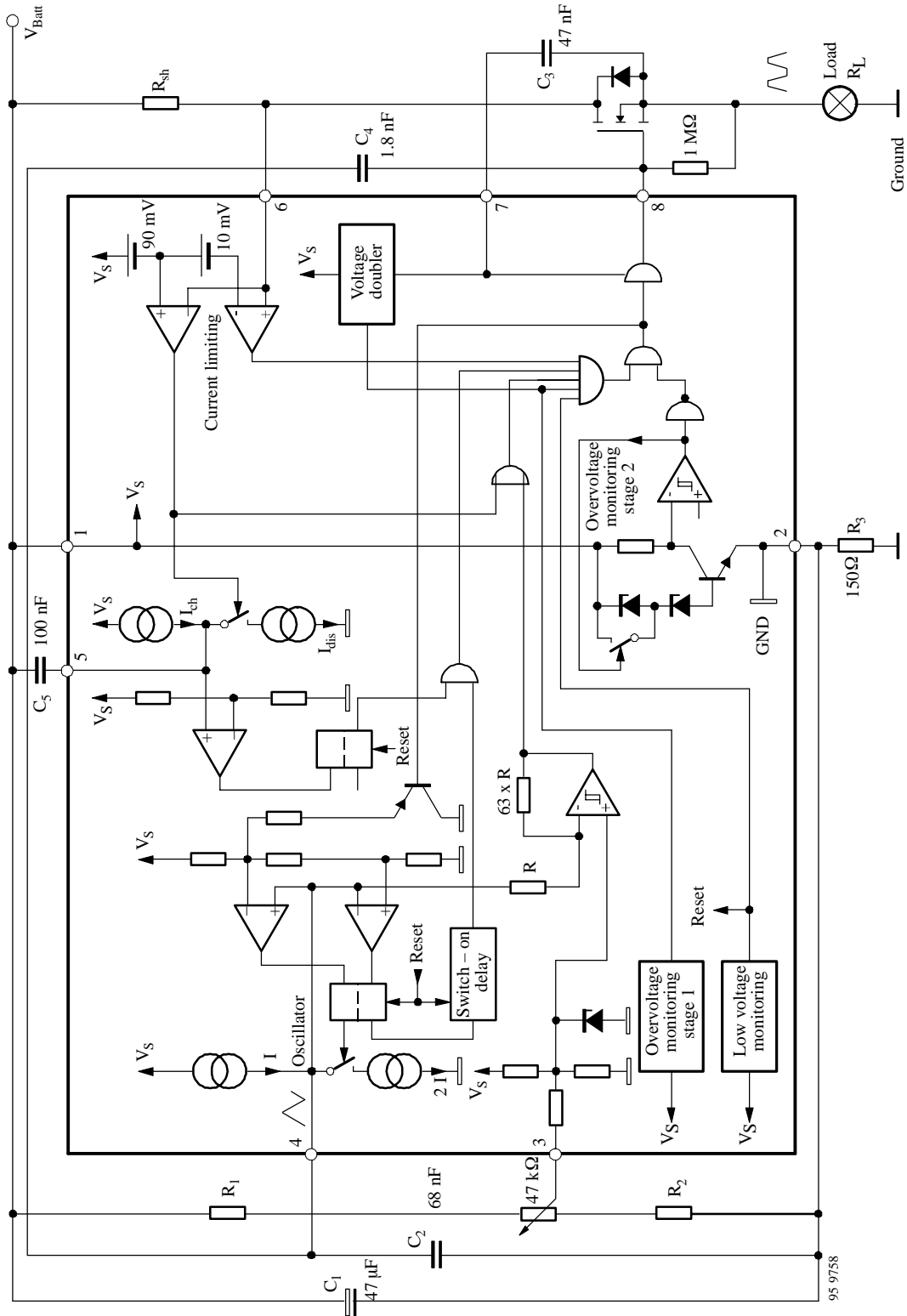
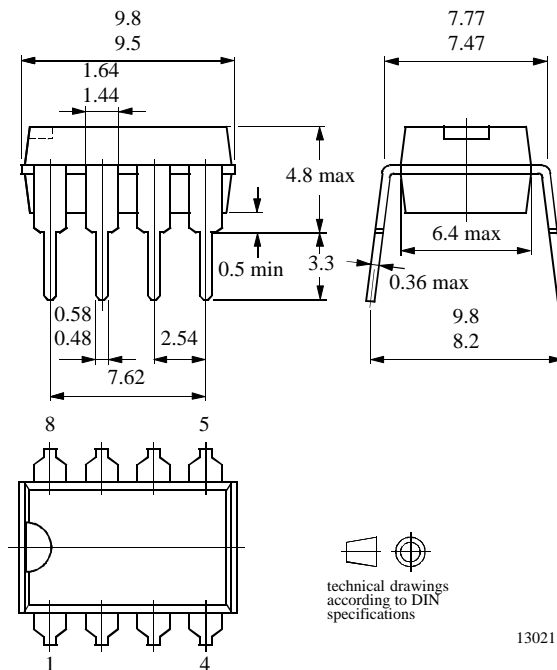

Figure 3. Application

Package Information

Package DIP8

Dimensions in mm



Ozone Depleting Substances Policy Statement

It is the policy of **Atmel Germany GmbH** to

1. Meet all present and future national and international statutory requirements.
2. Regularly and continuously improve the performance of our products, processes, distribution and operating systems with respect to their impact on the health and safety of our employees and the public, as well as their impact on the environment.

It is particular concern to control or eliminate releases of those substances into the atmosphere which are known as ozone depleting substances (ODSs).

The Montreal Protocol (1987) and its London Amendments (1990) intend to severely restrict the use of ODSs and forbid their use within the next ten years. Various national and international initiatives are pressing for an earlier ban on these substances.

Atmel Germany GmbH has been able to use its policy of continuous improvements to eliminate the use of ODSs listed in the following documents.

1. Annex A, B and list of transitional substances of the Montreal Protocol and the London Amendments respectively
2. Class I and II ozone depleting substances in the Clean Air Act Amendments of 1990 by the Environmental Protection Agency (EPA) in the USA
3. Council Decision 88/540/EEC and 91/690/EEC Annex A, B and C (transitional substances) respectively.

Atmel Germany GmbH can certify that our semiconductors are not manufactured with ozone depleting substances and do not contain such substances.

We reserve the right to make changes to improve technical design and may do so without further notice.

Parameters can vary in different applications. All operating parameters must be validated for each customer application by the customer. Should the buyer use Atmel Wireless & Microcontrollers products for any unintended or unauthorized application, the buyer shall indemnify Atmel Wireless & Microcontrollers against all claims, costs, damages, and expenses, arising out of, directly or indirectly, any claim of personal damage, injury or death associated with such unintended or unauthorized use.

Data sheets can also be retrieved from the Internet: <http://www.atmel-wm.com>

Atmel Germany GmbH, P.O.B. 3535, D-74025 Heilbronn, Germany
Telephone: 49 (0)7131 67 2594, Fax number: 49 (0)7131 67 2423