

THIS DOCUMENT AND THE DATA DISCLOSED  
HEREIN OR HEREWITH IS NOT TO BE REPRODUCED,  
USED, OR DISCLOSED IN WHOLE OR IN PART  
TO ANYONE WITHOUT PERMISSION OF VICOR CORP.

LTR.	DESCRIPTION	DATE	APP'D.
B1	REDRAWN & REVISED ECO #2107	3/84	

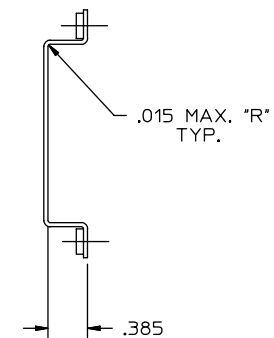
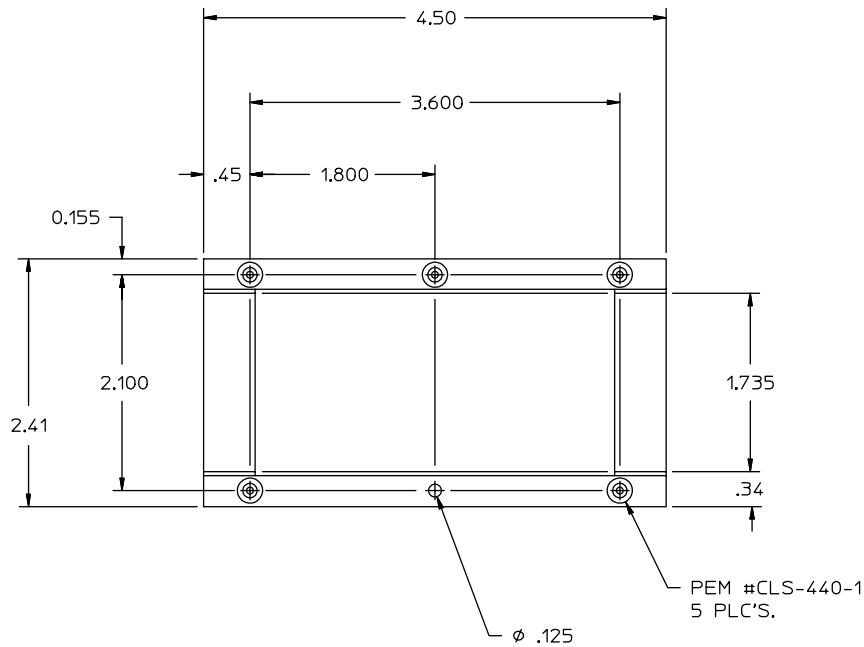

NOTES:

1. MATERIAL: 5052-H34 AL., .040 THICK.
2. REMOVE ALL BURRS & SHARP EDGES.
3. FINISH: CLEAR CHROMATE.

VICOR ANDOVER, MA. U.S.A.

DRAWN: J. WITEK 6/90	MODULE SHIELD	
CHECKED:		
APP'D:		
ALL DIMENSIONS ARE IN INCHES (MILLIMETERS)	TOLERANCES (EXCEPT AS NOTED) .XX ± .01 .XXX ± .005 FRACT ± 1/64 ANGLES ± 1°0	DRAWING NO. REV. 01039 B1
DO NOT SCALE DRAWING	SCALE: FULL	SHEET 1 OF 1
NEXT ASSY:		