

MAXIM

MAX3701 Evaluation Kit

General Description

The MAX3701 evaluation kit (EV-Kit) provides electrical evaluation of the MAX3701 blue laser driver. The evaluation kit also includes an optical evaluation section but true optical application requires a flex cable assembly.

Component List

DESIGNATION	QTY	DESCRIPTION
C1, C4, C6, C17, C29	5	0.01 μ F \pm 10% ceramic capacitor (0402)
C2, C3, C5, C7, C8, C10, C12, C13, C15, C16, C18, C22, C25, C26, C28, C30	16	0.1 μ F \pm 10% ceramic capacitor (0402)
C9	1	10pF \pm 1% ceramic capacitor (0402)
C11	1	18pF \pm 5% ceramic capacitor (0402)
C19	1	10pF \pm 5% ceramic capacitor (0603)
C14, C23, C24, C27	4	22 μ F \pm 5% tantalum capacitors (B Case)
D1	1	User-supplied laser diode
J1-J5	5	SMA connectors (edge-mount, tab contact)
JU1-JU15	15	2-pin headers (0.1in centers)
L1	1	1.3nH \pm 5% inductor
L5-L8	4	4.7 μ H \pm 5% inductors
Q1	1	PNP transistor (SOT23) FMMT591A Zetex
R1, R12, R13	3	Open
R2-R4, R9	4	49.9 Ω \pm 1% resistor (0402)
R5	1	20 Ω \pm 1% resistor (0402)
R6	1	22.6 Ω \pm 1% resistor (0805)
R7	1	90.9 Ω \pm 1% resistor (0805)
R8	1	27.4 Ω \pm 1% resistor (0805)
R10, R11, R26-R29, R35	7	10k Ω potentiometers
R14	1	10 Ω \pm 5% resistor (0603)
R15, R16, R19, R20, R25, R33	6	100 Ω \pm 1% resistors (0402)

Features

- ◆ Fully Assembled and Tested
- ◆ EV Kit Designed for 50 Ω Interfaces

Component List (cont.)

R17	1	10k Ω \pm 1% resistor (0402)
R18	1	8.25k Ω \pm 5% resistor (0402)
R21-R24	4	3.32k Ω \pm 1% resistors (0402)
R30	1	5k Ω potentiometer
R31	1	2k Ω \pm 1% resistor (0805)
R32	1	0 Ω \pm 5% resistor (0402)
R34	1	10k Ω \pm 1% resistor (0805)
TP1-TP6, TP11-TP17, TP23, TP24, TP26-TP29, TP32, TP33, J10-J13, J18, J19	27	Test points
U1	1	MAX3701CTJ
U2	1	MAX495ESA (8 SO)
U4, U5	2	MAX4477AUA
U6	1	User supplied photodiode

Ordering Information

PART	TEMP. RANGE	IC PACKAGE
MAX3701EVKIT	0 $^{\circ}$ C to +70 $^{\circ}$ C	32- QFN

Component Suppliers

SUPPLIER	PHONE	FAX
AVX	843-444-2863	843-626-3123
Coilcraft	847-639-6400	847-639-1469
Digi-Key	218-681-6674	218-681-3380
EF Johnson	402-474-4800	402-474-4858
Murata	415-964-6321	415-964-8165

Note: Please indicate that you are using the MAX3701 when ordering from these suppliers.

Evaluates: MAX3701

MAX3701 Evaluation Kit

Quick Start

The MAX3701 EV kit contains controls for setting the MAX3701 in a read or write format.

- 1) Install a shunt across JU9 to enable the chip. Remove shunt from JU3.
- 2) Connect a +3.3V power supply to J13. Connect ground to J12.
- 3) Connect a +5V power supply to J11. Connect ground to J10.
- 4) Connect a +9V power supply to J19. Connect ground to J18.
- 5) Monitor the voltage from TP32 to ground and adjust the R30 potentiometer until the voltage is around +3.2V.
- 6) Install a shunt across JU13. Adjust the R29 potentiometer until the desired bias level is achieved at the output. The bias level can be monitored by measuring the voltage across R6.
- 7) Connect J1 to a high-speed 50Ω oscilloscope. Attenuation may be necessary to meet the oscilloscope requirements, since the output voltage may exceed the maximum voltage for the oscilloscope. The output modulation current is the amplitude from the oscilloscope divided by 11.3Ω.

Read Mode

- 8) Install a shunt across JU5. Remove shunt from JU4.
- 9) Install shunts across JU1 and JU2.
- 10) Adjust the R10 potentiometer until the desired frequency is achieved at the output.
- 11) Adjust the R11 potentiometer until the desired amplitude is achieved at the output.

Write Mode

- 8) Install a shunt across JU4. Remove shunt from JU5.
- 9) Connect a data signal to any or all data inputs (J2, J3, J4, J5) Ensure that data is within the MAX3701 data sheet limits.
- 10) Install shunts across JU15, JU10, JU11 or JU12, depending on the input being controlled (V5, V4, V3 and V2 respectively). With shunts installed the voltage at these inputs are controlled by the potentiometers attached at the nodes (R35, R26, R27 and R28 respectively). It is important to note that the total output current must not exceed 200mA.

Installing a Laser Diode

The MAX3701 EV kit includes a footprint (D1) for evaluating the MAX3701 with a laser diode. Setup of the evaluation kit is the same as described in the previous section. The MAX3701 is designed to drive a blue laser diode. Due to the wavelength of a blue laser diode, precautions need to be taken for eye safety during test. The following steps need to be implemented to install the laser diode.

- 11) Remove L1, and install a 0Ω resistor for R13.
- 12) Connect the laser diode in the proper orientation. Refer to the schematic in Figure 1 for the proper orientation.
- 13) SB2, SB3 and SB4 can be used to connect the correct leads of the laser diode to ground. The connection will vary depending on the laser diode used.
- 14) Compensation for the laser diode output is implemented with the R5, C9 and R14, C19 networks. Compensation changes the rise and fall time. A compromise between the two needs to be achieved for proper operation.

Emulating a Monitor Diode

The MAX3701 EV Kit is equipped with a monitor diode emulation circuit to test the sample and hold function of the MAX3701. To use the monitor diode emulation circuit, follow these steps:

- 1) Ensure no monitor diode (U6) is installed.
- 2) Shunt solder bridge SB1.
- 3) Select monitor diode transimpedance gain with JU14. (High = 10kΩ, Low = 1.66kΩ)
- 4) Provide a clock for the sample and hold circuitry at TP6 with a range up to 1.0MHz.
- 5) Apply a voltage at TP3 proportional to the monitor diode current desired ($I_{MDIN} = V_{TP3}/8250\Omega$).
- 6) Monitor output of sample and hold circuit at TP4.

Installing a Monitor Diode

The MAX3701 EV Kit can accommodate a monitor diode installed at U6. To use the monitor diode, follow these steps:

- 1) Open solder bridge SB1.
- 2) Install monitor diode at U6. (Cathode = Pin 3, Anode = Pin 2)
- 3) Select monitor diode transimpedance gain with JU14. (High = 10kΩ, Low = 1.66kΩ)
- 4) Provide a clock for the sample and hold circuitry at TP6 with a range up to 1.0MHz.
- 5) Monitor output of sample and hold circuit at TP4.

MAX3701 Evaluation Kit

Evaluates: MAX3701

Adjustment and Control Description (see Quick Start first)

COMPONENT	NAME	FUNCTION
JU1	-	Shunting this jumper connects the FREQ pin to the R10 potentiometer. Leaving this jumper open allows the uninstalled R1 fixed resistor to control the FREQ pin. Used for read mode control.
JU2	-	Shunting this jumper connects the AMP pin to the R11 potentiometer. Leaving this jumper open allows the uninstalled R12 fixed resistor to control the AMP pin. Used for read mode control.
JU3	-	Shunting this jumper connects the EN pin to GND. When shunted the chip is enabled.
JU4	-	Shunting this jumper connects the RWB pin to GND. When shunted the write function is enabled.
JU5	-	Shunting this jumper connects the RWB pin to +3.3V. When shunted the read function is enabled.
JU6	-	Shunting this jumper connects the SCLK pin to GND. When shunted a static low is created on the SCLK input.
JU7	-	Shunting this jumper connects the SCLK pin to +3.3V. When shunted a static high is created on the SCLK input.
JU8	-	Shunting this jumper shorts the filter network on the V1 input. Leaving this jumper open implements the filter network on the V1 input.
JU9	-	Shunting this jumper connects the EN pin to +3.3V. When shunted the chip is disabled.
JU10	-	Shunting this jumper connects the V4 pin to the R26 potentiometer. Used for write mode.
JU11	-	Shunting this jumper connects the V3 pin to the R27 potentiometer. Used for write mode.
JU12	-	Shunting this jumper connects the V2 pin to the R28 potentiometer. Used for write mode.
JU13	-	Shunting this jumper connects the V1 pin to the R29 potentiometer.
JU14	-	Shunting this jumper connects the SEL pin to +3.3V. Leaving this jumper open connects the SEL pin to GND through a 10kΩ resistor.
JU15	-	Shunting this jumper connects the V5 pin to the R35 potentiometer. Used for write mode.
R10	FREQ	Adjusts the frequency of the output while the part is in the read mode.
R11	AMP	Adjusts the amplitude of the output while the part is in the read mode.
R26	V4	Adjusts the voltage at the V4 pin, controls the current contributed to the output by this channel.
R27	V3	Adjusts the voltage at the V3 pin, controls the current contributed to the output by this channel.
R28	V2	Adjusts the voltage at the V2 pin, controls the current contributed to the output by this channel.
R29	V1	Adjusts the voltage at the V1 pin, controls the current contributed to the output by this channel.
R30	-	Adjusts the biasing voltage at the output to account for the blue laser diode model voltage drop.
R35	V5	Adjusts the voltage at the V5 pin, which controls the current contributed to the output by this channel.

MAX3701 Evaluation Kit

Evaluates: MAX3701

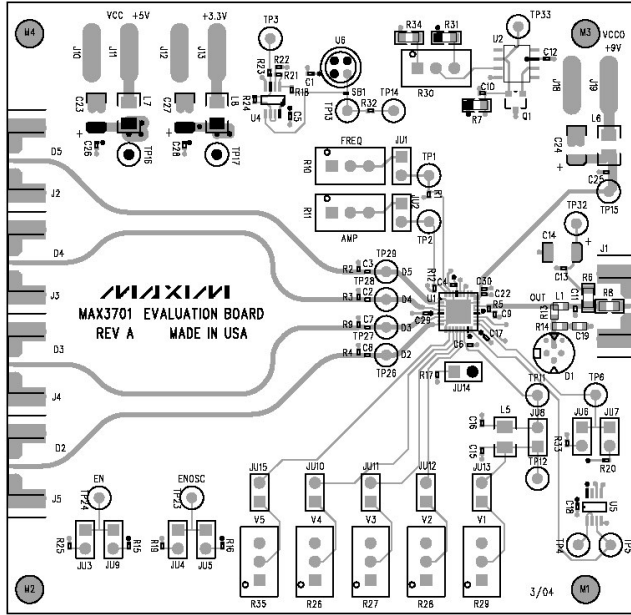

Figure 2. MAX3701 EV Kit Component Placement Guide - Component Side

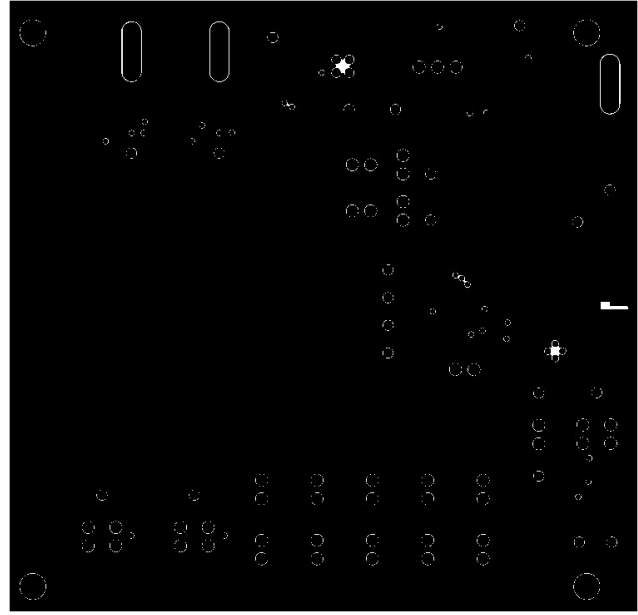

Figure 3. MAX3701 EV Kit PC Board Layout - Ground Plane

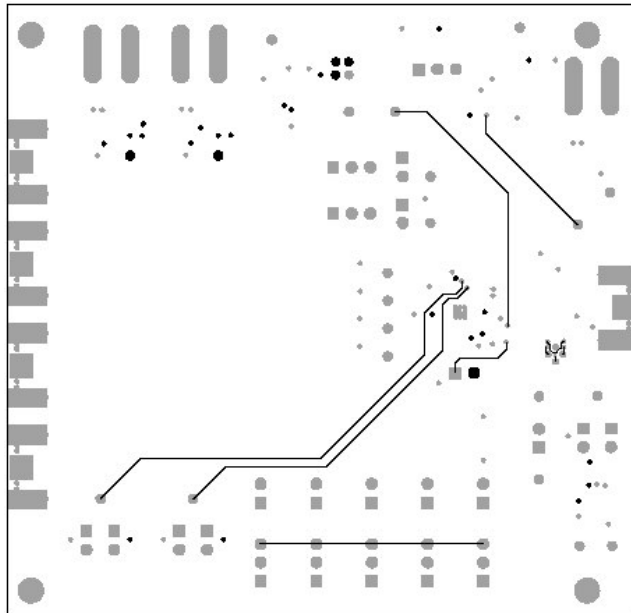

Figure 4. MAX3701 EV Kit PC Board Layout - Solder Side

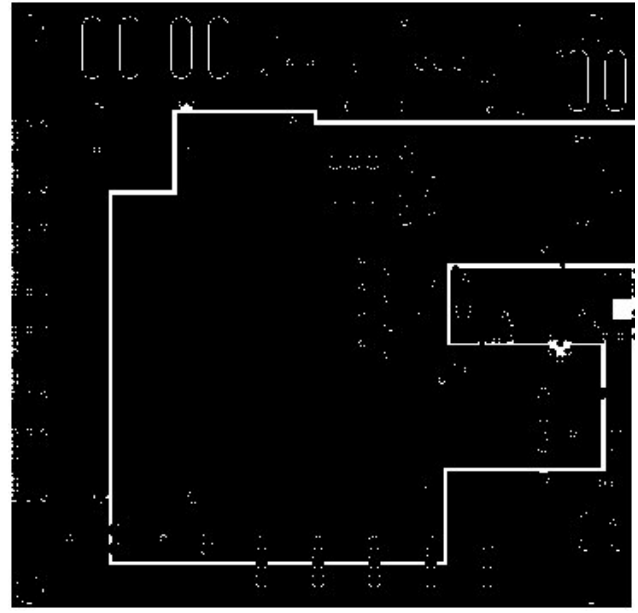

Figure 5. MAX3701 EV Kit PC Board Layout - Power Plane

Maxim cannot assume responsibility for use of any circuitry other than circuitry entirely embodied in a Maxim product. No circuit patent licenses are implied. Maxim reserves the right to change the circuitry and specifications without notice at any time.

Maxim Integrated Products, 120 San Gabriel Drive, Sunnyvale, CA 94086 408-737-7600

5