



# MAX8724 Evaluation Kit

**Evaluates: MAX8724**

## General Description

The MAX8724 evaluation kit (EV kit) is an accurate and efficient multichemistry battery charger. It uses analog inputs to control charge voltage and current. The EV kit can charge 2 to 4 series lithium-ion (Li+) cells with a current up to 3A. High efficiency is achieved by a buck topology with synchronous rectification. The EV kit provides outputs that can be used to monitor the input current, the battery-charging current, and the presence of an AC adapter.

## Ordering Information

PART	TEMP RANGE	IC PACKAGE
MAX8724EVKIT	0°C to +70°C	28 QFN

## Features

- ◆ Input Current Limiting
- ◆  $\pm 0.5\%$  Battery-Voltage Set-Point Accuracy Using Internal Reference
- ◆ Analog Inputs Control Charge Current and Battery-Voltage Set Point
- ◆ Monitor Outputs for
  - Current Drawn from AC Input Source
  - Charging Current
  - AC Adapter Presence
- ◆ Up to 17.6V Battery-Voltage Set Point
- ◆ +8V to +25V Input Voltage
- ◆ 3A Battery Charge Current
- ◆ Charges Any Battery Chemistry: Li+, NiCd, NiMH, Lead Acid, etc.
- ◆ Surface-Mount Construction
- ◆ Fully Assembled and Tested

## Component List

DESIGNATION	QTY	DESCRIPTION
C1, C4	2	22 $\mu$ F $\pm 20\%$ , 25V X5R ceramic capacitors (2220) TDK C5750X5R1E226M
C2, C3	0	Not installed (2220)
C5, C6	0	Not installed, E size
C7, C8, C9, C13, C14, C15, C17	0	Not installed (0603)
C10	1	4.7 $\mu$ F $\pm 10\%$ , 6.3V X5R ceramic capacitor (0603) TDK C1608X5R0J475K
C11, C23	2	1 $\mu$ F $\pm 10\%$ , 6.3V X5R ceramic capacitors (0603) Murata GRM188R60J105K Taiyo Yuden JMK107BJ105KA TDK C1608X5R1A105K
C12, C18, C19, C20	4	0.1 $\mu$ F $\pm 10\%$ , 25V X7R ceramic capacitors (0603) Murata GRM188R71E104K TDK C1608X7R1E104K

DESIGNATION	QTY	DESCRIPTION
C16	1	1 $\mu$ F $\pm 10\%$ , 25V X7R ceramic capacitor (1206) Murata GRM31MR71E105K Taiyo Yuden TMK316BJ105KL TDK C3216X7R1E105K
C21, C22	2	0.01 $\mu$ F $\pm 10\%$ , 50V X7R ceramic capacitors (0603) Murata GRM188R71H103K Taiyo Yuden UMK107B103KZ TDK C1608X7R1H103K
D1	1	Schottky diode, 10A, DPAK Diodes Inc. MBRD1035CTL ON Semiconductor MBRD1035CTL
D2, D3	2	Schottky diodes, 0.5A, 30V SOD-123 Diodes Inc. B0530W General Semiconductor MBR0530 ON Semiconductor MBR0530
D4	1	Schottky diode, 1A, 40V, SMA Central Semiconductor CMSH1-40ML Diodes Inc. B130L

# MAX8724 Evaluation Kit

## Component List (continued)

DESIGNATION	QTY	DESCRIPTION
J1	1	Smart-battery header assembly, right angle, keyless, 5-position Tyco Electronics 787441-1
JU1	1	2-pin header
JU2, JU3, JU5, JU6	4	3-pin headers
JU4	0	Not installed
L1	1	10 $\mu$ H, 4.4A inductor Sumida CDRH104R-100NC TOKO 919AS-100M
N1	1	Dual, n-channel, 8-pin SO, MOSFET Fairchild FDS6912A
P1	0	Not installed
R1	1	0.01 $\Omega$ $\pm$ 1%, 0.5W sense resistor (2010) Vishay Dale WSL2010 0.010 1.0% IRC LRC-LR2010-01-R010-F
R2	1	0.015 $\Omega$ $\pm$ 1%, 0.5W sense resistor (2010) Vishay Dale WSL2010 0.015 1.0% IRC LRC-LR2010-01-R015-F
R3–R6, R14, R15, R17–R20, R22, R23, R24	0	Not installed (0603)
R7	1	590k $\Omega$ $\pm$ 1% resistor (0603)
R8	1	196k $\Omega$ $\pm$ 1% resistor (0603)
R9	1	4.7k $\Omega$ $\pm$ 5% resistor (0603)
R10, R11	2	10k $\Omega$ $\pm$ 5% resistors (0603)
R12, R13	2	50k $\Omega$ potentiometers (multiturn)
R16	1	33 $\Omega$ $\pm$ 5% resistor (0603)
R21	1	1M $\Omega$ $\pm$ 5% resistor (0603)
R25	1	10 $\Omega$ $\pm$ 5% resistor (0603)
U1	1	MAX8724ET1 (28-pin QFN-EP)

## Quick Start

### Required Equipment

Before beginning, the following equipment is required:

- DC source to supply the input current to the charger. This source must be capable of supplying a voltage greater than the battery-voltage set point and have a sufficient current rating.

- DC source capable of supplying a voltage between +2.5V to +3.6V for REFIN.
- Voltmeter.
- Battery pack or load.

### Procedure

The MAX8724 EV kit is a fully assembled and tested surface-mount board. Follow the steps below to verify board operation. **Do not turn on the power supply until all connections are completed. Observe all precautions on the battery manufacturer's data sheet:**

- 1) Install a shunt on JU1 to set the battery-voltage set point to 4.2V per cell. If a different battery-voltage set point is required, see the *Battery-Voltage Set Point* section.
- 2) Place a shunt across pins 1-2 on JU2 to enable 3A charging-current limit. If the battery is not rated for 3A charge current, then select a charge current and set as explained in the *Charging-Current Limit (Potentiometer R12)* section.
- 3) Set jumper JU5 to indicate the number of cells in the battery pack (Table 1).
- 4) Place a shunt across pins 2-3 on JU6.
- 5) Place a shunt across pins 2-3 on JU3 to disable the MAX8724.
- 6) Connect the input-current supply across the ADAPTER\_IN and PGND pads.
- 7) Connect the +2.5VDC to +3.6VDC power supply to REFIN and GND.
- 8) Connect a battery pack between the BATT+ and BATT- pads.
- 9) Turn on the power supplies.
- 10) Enable the MAX8724 by moving the shunt on JU3 to the 1-2 position.
- 11) Verify current is being delivered to the battery.

## Detailed Description

The MAX8724 includes all the functions necessary to charge Li+ batteries. The EV kit is shipped with a charging-current limit of 3A and a battery-voltage set point of 4.2V times the number of cells in the battery pack.

The MAX8724 charges the battery pack at a constant current of 3A (the charging-current limit) until the battery pack voltage reaches 4.2V times the number of cells (the battery-voltage set point). At this time, the MAX8724 charges the battery pack with a constant voltage equal to the battery-voltage set point.

**Note:** During charging, if the source-current limit is reached, the charge current decreases.

# MAX8724 Evaluation Kit

For more information on the operation of the MAX8724, refer to the *Detailed Description* section of the MAX1908/MAX8724 data sheet.

## Jumper JU1

Jumper JU1 connects VCTL to LDO. This sets the battery-voltage set point to 4.2V x the number of cells.

The battery-voltage set point can be set between 4.0V and 4.4V (times the number of cells) by removing the shunt on JU1 and installing resistors at R5 and R6. See the *Battery-Voltage Set Point* section for more information.

## Jumper JU2

Jumper JU2 connects ICTL to either LDO or potentiometer R12. Connecting ICTL to LDO sets the charging-current limit to 3A. Connecting ICTL to potentiometer R12 provides adjustment of the charging-current limit to between 0.156A and 5A. Refer to the *Setting the Charging-Current Limit* section of the MAX1908/MAX8724 data sheet for more information.

**Note:** Applying a voltage less than REFIN / 32 to ICTL places the MAX8724 in shutdown mode; 5A charging current requires a different inductor. The 8-pin SO dual MOSFET (N1) is capable of handling 5A at room temperature only. For a higher ambient temperature, replace it with two single 8-pin SO MOSFETs.

## Jumper JU3

Jumper JU3 either enables the MAX8724 or places it into shutdown. See Table 1 for jumper settings.

## Jumper JU4

Jumper JU4 is factory reserved.

## Jumper JU5

Jumper JU5 selects the number of series cells to be charged. See Table 1 for jumper settings.

## Jumper JU6

Jumper JU6 connects ACOK to either a 1MΩ pullup resistor or to an optional MOSFET circuit (P1, R22, and R23). Using a MOSFET provides a lower dropout voltage than Schottky diode D1.

Use a p-channel MOSFET such as Fairchild FDS6675 for P1. Choose resistor values for R22 and R23 that ensure V<sub>GS</sub> is not exceeded on the MOSFET.

## Battery-Voltage Set Point

The default battery-voltage set point on the MAX8724 EV kit is 4.2V times the number of cells. To set it to a

value between 4.0V and 4.4V (times the number of cells), remove the shunt on JU1 and install resistors at R5 and R6. Use the following equation to calculate the resistor values:

$$R5 = R6 \left( \frac{0.4}{\frac{V_{BATT}}{CELLS} - 4} - 1 \right)$$

where V<sub>BATT</sub> is the desired battery-voltage set point and CELLS is the number of cells selected by jumper JU5.

Choose 1% resistors with a total resistance less than 250kΩ to minimize error caused by bias current.

For V<sub>BATT</sub> / CELLS = 4, use 100kΩ for R6 and leave R5 uninstalled.

## Charging-Current Limit (Potentiometer R12)

The default charging-current limit on the MAX8724 EV kit is 3A. To set it to a value between 0.156A and 5A, move the shunt on jumper JU2 to the 2-3 position and adjust potentiometer R12. Refer to the *Setting the Charging-Current Limit* section of the MAX1908/MAX8724 data sheet for more information.

**Note:** Five-amp charging current requires a different inductor. The 8-pin SO dual MOSFET (N1) is capable of handling 5A at room temperature only. For a higher ambient temperature, replace it with two single 8-pin SO MOSFETs.

## Source-Current Limit (Potentiometer R13)

Potentiometer R13 is connected to CLS, the source-current-limit input. Adjusting R13 allows the input-current limit to be set between 3.75A and 7.5A. Refer to the *Setting the Input-Current Limit* section of the MAX1908/MAX8724 data sheet for more information.

## Evaluating the MAX8724 Above 25V

To evaluate the MAX8724 with an input voltage greater than 25V (up to 28V), capacitors C1 and C16 must be replaced with higher voltage rating parts. Any capacitors that were installed in locations C2, C5, C6, C7, and C9 must also meet the higher voltage rating.

# MAX8724 Evaluation Kit

**Table 1. Jumper Selection**

JUMPER	JUMPER POSITION	FUNCTION
JU1	Open	Battery-voltage set point can be set between 4.0V and 4.4V times the number of cells. Resistors R5 and R6 must be installed.
	Closed*	VCTL = LDO. Battery-voltage set point set to 4.2V times the number of cells.
JU2	1-2*	ICTL = LDO. Charging-current limit set to 3A.
	2-3	ICTL connected to potentiometer R12. Charging-current limit can be adjusted between 0.156A ( $V_{ICTL} = \text{REFIN} / 32$ ) and 5A ( $V_{ICTL} = \text{REFIN}$ ). <b>Note:</b> $V_{ICTL} < \text{REFIN} / 32$ places the MAX8724 in shutdown.
JU3	1-2*	$\overline{\text{SHDN}}$ = high. MAX8724 enabled.
	2-3	$\overline{\text{SHDN}}$ = low. MAX8724 disabled.
	Open	Drive pad $\overline{\text{SHDN}}$ with an external signal.
JU4	Open	Factory reserved.
	Closed* (shorted by PC board trace)	Normal operation.
JU5	1-2	CELL = REFIN, cell count = 4.
	2-3*	CELL = GND, cell count = 2.
	Open	CELL = float, cell count = 3.
JU6	1-2	$\overline{\text{ACOK}}$ connected to optional MOSFET circuit (P1, R22, and R23).
	2-3*	$\overline{\text{ACOK}}$ connected to 1M $\Omega$ pullup resistor.

\*Default position.

## Component Suppliers

SUPPLIER	PHONE	FAX	WEBSITE
Central Semiconductor	631-435-1110	631-435-1824	www.centralsemi.com
Diodes Inc.	805-446-4800	805-381-3899	www.diodes.com
Fairchild Semiconductor	888-522-5372	972-910-8036	www.fairchildsemi.com
General Semiconductor	760-804-9258	760-804-9259	www.gensemi.com
International Resistive Co. (IRC)	361-992-7900	361-992-3377	www.irctt.com
Murata	770-436-1300	770-436-3030	www.murata.com
ON Semiconductor	602-244-6600	602-244-4545	www.onsemi.com
Sumida	847-545-6700	847-545-6720	www.sumida.com
Taiyo Yuden	800-348-2496	847-925-0899	www.t-yuden.com
TDK	847-803-6100	847-390-4405	www.component.tdk.com
TOKO	847-297-0070	847-699-1194	www.tokoam.com
Vishay Dale	402-564-3131	402-563-6296	www.vishay.com

**Note:** Indicate you are using the MAX8724 when contacting these manufacturers.

# MAX8724 Evaluation Kit

Evaluates: MAX8724

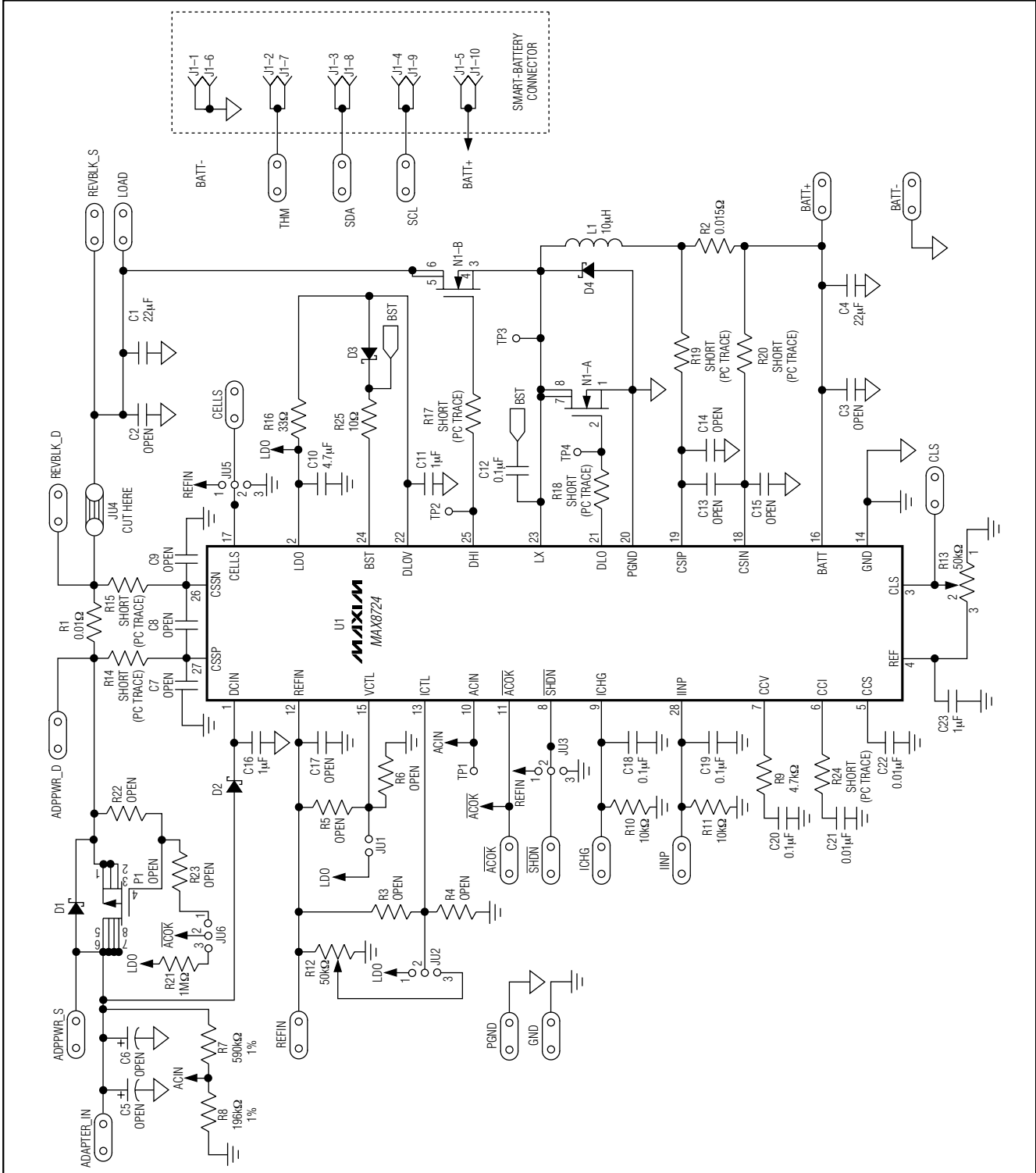

Figure 1. MAX8724 EV Kit Schematic

# MAX8724 Evaluation Kit

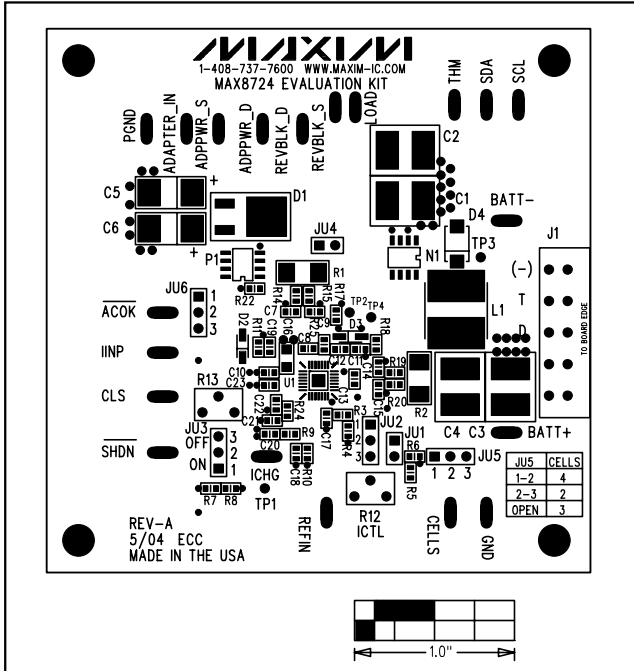

Figure 2. MAX8724 EV Kit Component Placement Guide—Component Side

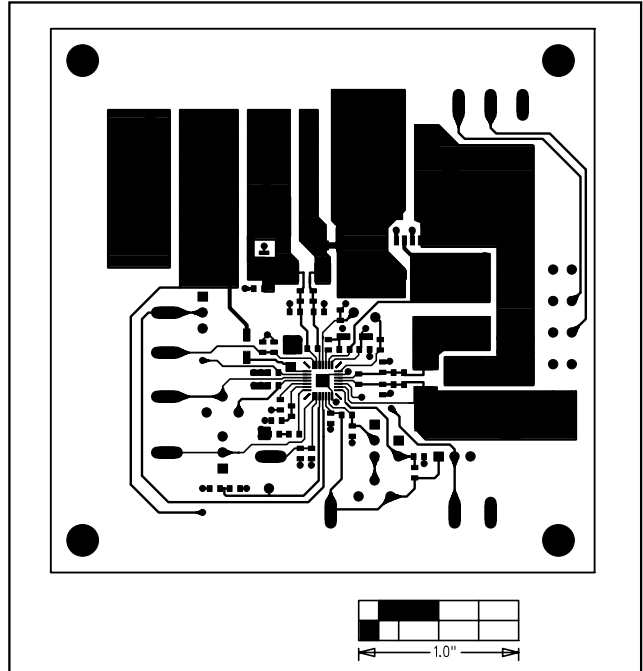

Figure 3. MAX8724 EV Kit PC Board Layout—Component Side

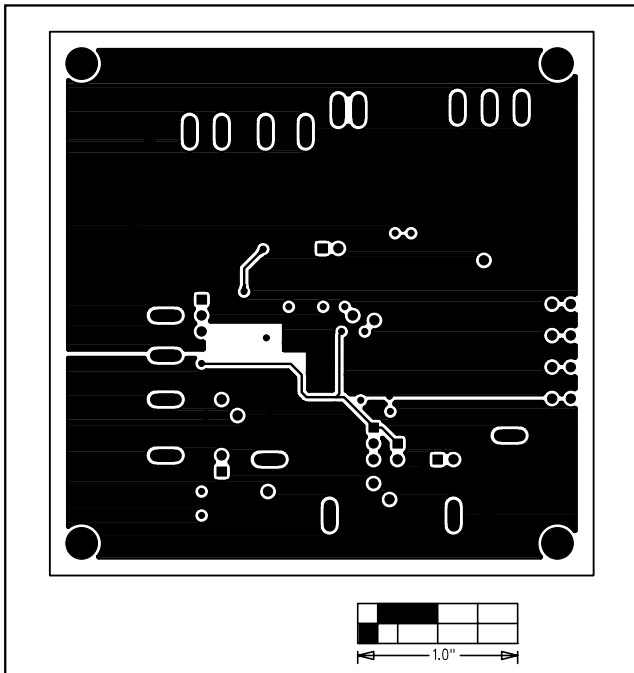

Figure 4. MAX8724 EV Kit PC Board Layout—Signal and Ground Layer

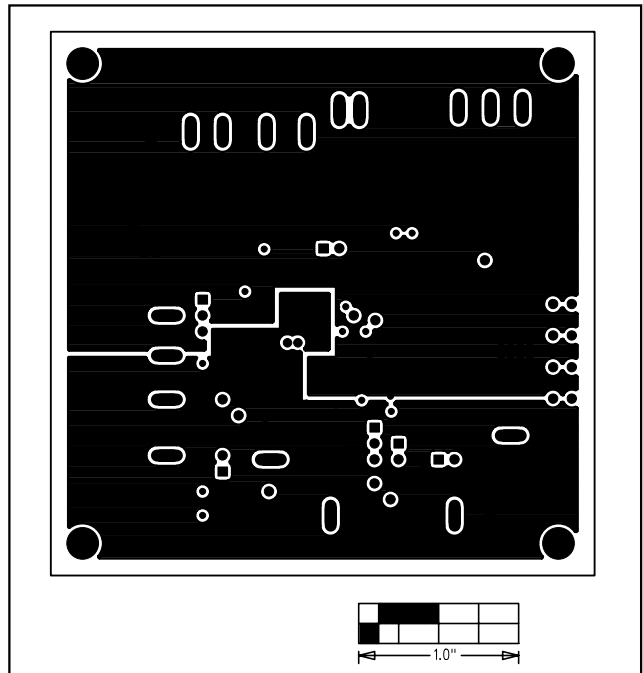

Figure 5. MAX8724 EV Kit PC Board Layout—Ground Layer

# MAX8724 Evaluation Kit

**Evaluates: MAX8724**

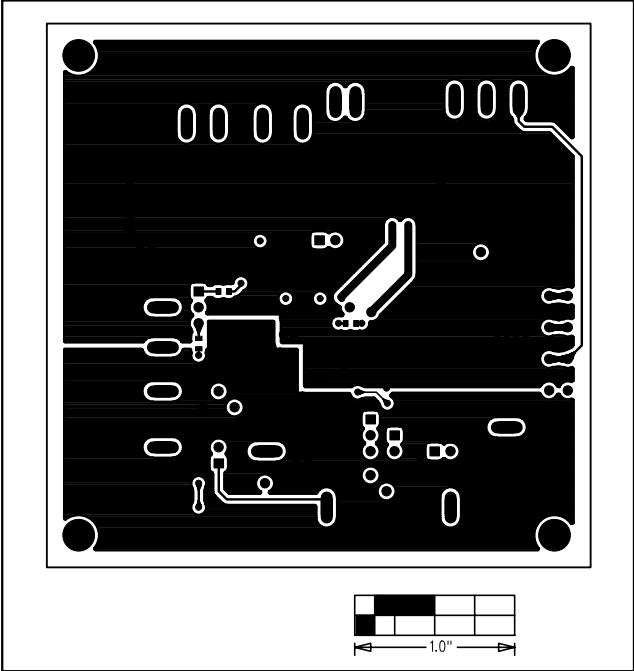

Figure 6. MAX8724 EV Kit PC Board Layout—Solder Side

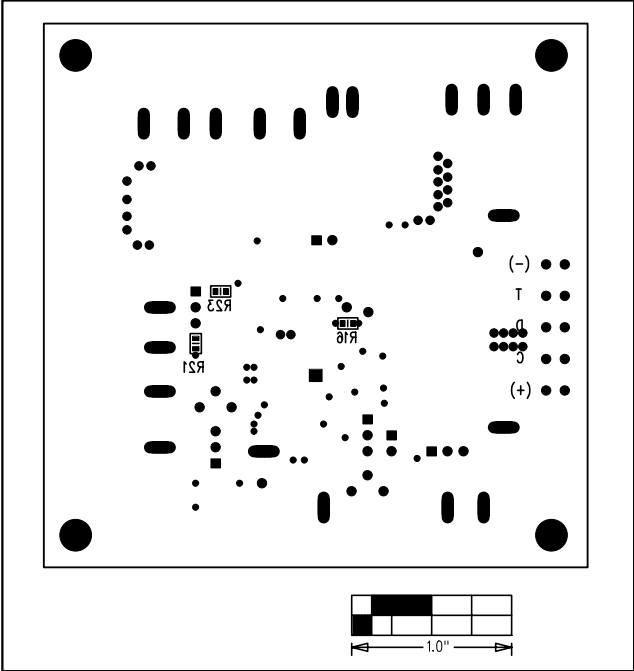

Figure 7. MAX8724 EV Kit PC Board Layout—Solder Side

Maxim cannot assume responsibility for use of any circuitry other than circuitry entirely embodied in a Maxim product. No circuit patent licenses are implied. Maxim reserves the right to change the circuitry and specifications without notice at any time.

**Maxim Integrated Products, 120 San Gabriel Drive, Sunnyvale, CA 94086 408-737-7600** \_\_\_\_\_ 7