

Integrated Silicon Pressure Sensor On-Chip Signal Conditioned, Temperature Compensated and Calibrated

MPXV4006G SERIES

The MPXV4006G series piezoresistive transducer is a state-of-the-art monolithic silicon pressure sensor designed for a wide range of applications, but particularly those employing a microcontroller or microprocessor with A/D inputs. This sensor combines a highly sensitive implanted strain gauge with advanced micromachining techniques, thin-film metallization, and bipolar processing to provide an accurate, high level analog output signal that is proportional to the applied pressure.

**INTEGRATED
 PRESSURE SENSOR
 0 to 6 kPa (0 to 0.87 psi)
 0.2 to 4.7 V OUTPUT**

Features

- Temperature Compensated over 10° to 60°C
- Ideally Suited for Microprocessor or Microcontroller-Based Systems
- Available in Gauge Surface Mount (SMT) or Through-hole (DIP) Configurations
- Durable Thermoplastic (PPS) Package

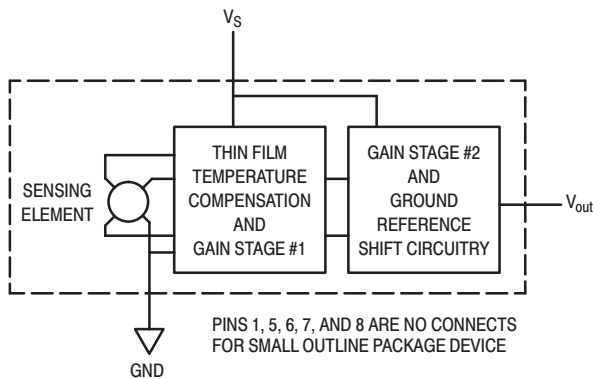

Figure 1. Fully Integrated Pressure Sensor Schematic

**SMALL OUTLINE PACKAGE
 SURFACE MOUNT**

**MPXV4006G6U
 CASE 482**

**MPXV4006GC6U
 CASE 482A**

**MPXV4006GP
 CASE 1369**

**MPXV4006DP
 CASE 1351**

**SMALL OUTLINE PACKAGE
 THROUGH-HOLE**

**MPXV4006G7U
 CASE 482B**

**MPXV4006GC7U
 CASE 482C**

PIN NUMBER			
1	N/C	5	N/C
2	V _S	6	N/C
3	Gnd	7	N/C
4	V _{out}	8	N/C

NOTE: Pins 1, 5, 6, 7, and 8 are internal device connections. Do not connect to external circuitry or ground. Pin 1 is noted by the notch in the lead.

Replaces MPXT4006D/D

REV 4

Freescale Semiconductor, Inc.

MAXIMUM RATINGS(NOTE)

Parameters	Symbol	Value	Unit
Maximum Pressure (P1 > P2)	P_{max}	24	kPa
Storage Temperature	T_{stg}	-30 to +100	°C
Operating Temperature	T_A	+10 to +60	°C

NOTE: Exposure beyond the specified limits may cause permanent damage or degradation to the device.

OPERATING CHARACTERISTICS ($V_S = 5.0$ Vdc, $T_A = 25^\circ\text{C}$ unless otherwise noted, P1 > P2. Decoupling circuit shown in Figure 3 required to meet electrical specifications.)

Characteristic	Symbol	Min	Typ	Max	Unit
Pressure Range	P_{OP}	0	—	6.0	kPa
Supply Voltage ⁽¹⁾	V_S	4.75	5.0	5.25	Vdc
Supply Current	I_S	—	—	10	mAdc
Full Scale Span ⁽²⁾	(RL = 51kΩ) V_{FSS}	—	4.6	—	V
Offset ⁽³⁾⁽⁵⁾	(RL = 51kΩ) V_{off}	0.100	0.225	0.430	V
Sensitivity	V/P	—	766	—	mV/kPa
Accuracy ⁽⁴⁾⁽⁵⁾	(10 to 60°C)	—	—	±5.0	% V_{FSS}

NOTES:

- Device is ratiometric within this specified excitation range.
- Full Scale Span (V_{FSS}) is defined as the algebraic difference between the output voltage at full rated pressure and the output voltage at the minimum rated pressure.
- Offset (V_{off}) is defined as the output voltage at the minimum rated pressure.
- Accuracy (error budget) consists of the following:
 - Linearity: Output deviation from a straight line relationship with pressure over the specified pressure range.
 - Temperature Hysteresis: Output deviation at any temperature within the operating temperature range, after the temperature is cycled to and from the minimum or maximum operating temperature points, with zero differential pressure applied.
 - Pressure Hysteresis: Output deviation at any pressure within the specified range, when this pressure is cycled to and from the minimum or maximum rated pressure, at 25°C.
 - Offset Stability: Output deviation, after 1000 temperature cycles, -30 to 100°C, and 1.5 million pressure cycles, with minimum rated pressure applied.
 - TcSpan: Output deviation over the temperature range of 10 to 60°C, relative to 25°C.
 - TcOffset: Output deviation with minimum rated pressure applied, over the temperature range of 10 to 60°C, relative to 25°C.
 - Variation from Nominal: The variation from nominal values, for Offset or Full Scale Span, as a percent of V_{FSS} , at 25°C.
- Auto Zero at Factory Installation: Due to the sensitivity of the MPXV4006G, external mechanical stresses and mounting position can affect the zero pressure output reading. To obtain the 5% FSS accuracy, the device output must be "autozeroed" after installation. Autozeroing is defined as storing the zero pressure output reading and subtracting this from the device's output during normal operations.

ON-CHIP TEMPERATURE COMPENSATION, CALIBRATION AND SIGNAL CONDITIONING

The performance over temperature is achieved by integrating the shear-stress strain gauge, temperature compensation, calibration and signal conditioning circuitry onto a single monolithic chip.

Figure 2 illustrates the gauge configuration in the basic chip carrier (Case 482). A fluorosilicone gel isolates the die surface and wire bonds from the environment, while allowing the pressure signal to be transmitted to the silicon diaphragm.

The MPXV4006G series sensor operating characteristics are based on use of dry air as pressure media. Media, other than dry air, may have adverse effects on sensor performance and long-term reliability. Internal reliability and qualification

test for dry air, and other media, are available from the factory. Contact the factory for information regarding media tolerance in your application.

Figure 3 shows the recommended decoupling circuit for interfacing the output of the integrated sensor to the A/D input of a microprocessor or microcontroller. Proper decoupling of the power supply is recommended.

Figure 4 shows the sensor output signal relative to pressure input. Typical, minimum and maximum output curves are shown for operation over a temperature range of 10°C to 60°C using the decoupling circuit shown in Figure 3. The output will saturate outside of the specified pressure range.

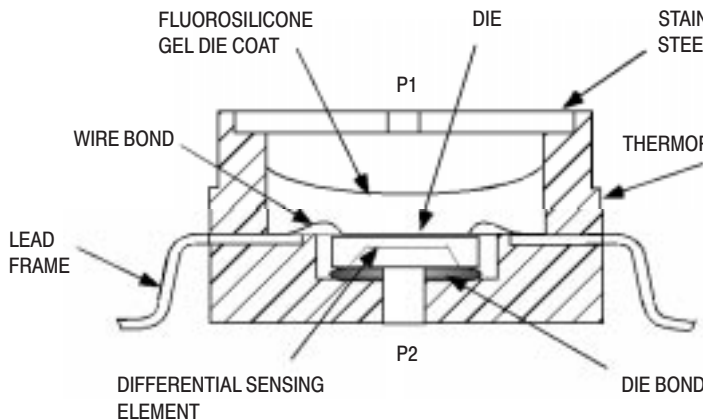

Figure 2. Cross-Sectional Diagram (Not to Scale)

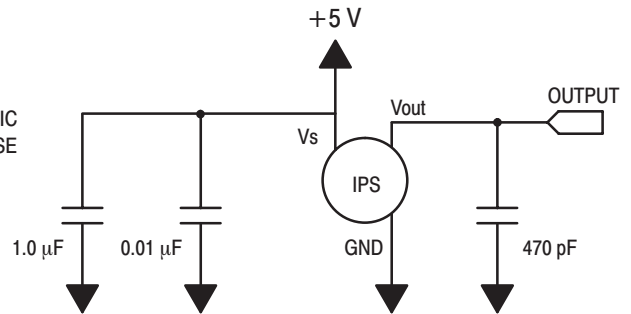

Figure 3. Recommended power supply decoupling and output filtering recommendations. For additional output filtering, please refer to Application Note AN1646.

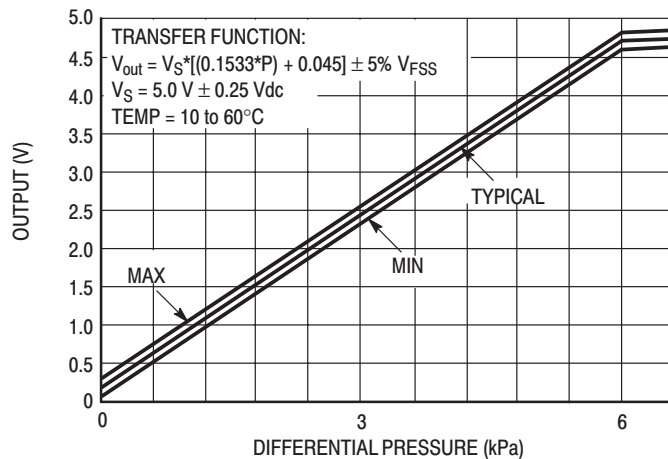

Figure 4. Output versus Pressure Differential

(See Note 5 in Operating Characteristics)

PRESSURE (P1)/VACUUM (P2) SIDE IDENTIFICATION TABLE

Motorola designates the two sides of the pressure sensor as the Pressure (P1) side and the Vacuum (P2) side. The Pressure (P1) side is the side containing silicone gel which isolates the die from the environment. The Motorola pres-

sure sensor is designed to operate with positive differential pressure applied, P1 > P2.

The Pressure (P1) side may be identified by using the table below:

Part Number	Case Type	Pressure (P1) Side Identifier
MPXV4006G6U/T1	482	Stainless Steel Cap
MPXV4006GC6U/T1	482A	Side with Port Attached
MPXV4006G7U	482B	Stainless Steel Cap
MPXV4006GC7U	482C	Side with Port Attached
MPXV4006GP	1369	Side with Port Attached
MPXV4006DP	1351	Side with Part Marking

ORDERING INFORMATION

MPXV4006G series pressure sensors are available in the basic element package or with pressure ports. Two packing options are offered for the 482 and 482A case configurations.

Device Type	Options	Case No.	MPX Series Order No.	Packing Options	Marking
Basic Element	Element Only	482	MPXV4006G6U	Rails	MPXV4006G
	Element Only	482	MPXV4006G6T1	Tape and Reel	MPXV4006G
	Element Only	482	MPXV4006G7U	Rails	MPXV4006G
Ported Element	Axial Port	482A	MPXV4006GC6U	Rails	MPXV4006G
	Axial Port	482A	MPXV4006GC6T1	Tape and Reel	MPXV4006G
	Axial Port	482A	MPXV4006GC7U	Rails	MPXV4006G
	Side Port	1369	MPXV4006GP	Trays	MPXV4006G
	Dual Port	1351	MPXV4006DP	Trays	MPXV4006G

MINIMUM RECOMMENDED FOOTPRINT FOR SURFACE MOUNTED APPLICATIONS

Surface mount board layout is a critical portion of the total design. The footprint for the surface mount packages must be the correct size to ensure proper solder connection interface between the board and the package. With the correct

footprint, the packages will self align when subjected to a solder reflow process. It is always recommended to design boards with a solder mask layer to avoid bridging and shorting between solder pads.

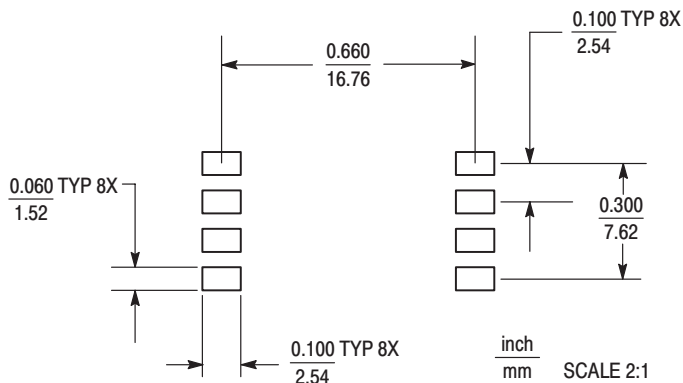
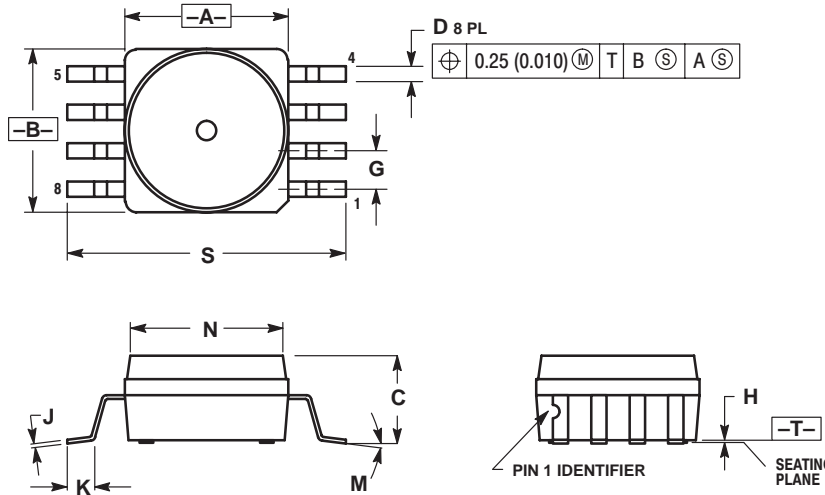

Figure 5. SOP Footprint (Case 482)

SMALL OUTLINE PACKAGE DIMENSIONS
SURFACE MOUNT



- NOTES:
1. DIMENSIONING AND TOLERANCING PER ANSI Y14.5M, 1982.
 2. CONTROLLING DIMENSION: INCH.
 3. DIMENSION A AND B DO NOT INCLUDE MOLD PROTRUSION.
 4. MAXIMUM MOLD PROTRUSION 0.15 (0.006).
 5. ALL VERTICAL SURFACES 5° TYPICAL DRAFT.

DIM	INCHES		MILLIMETERS	
	MIN	MAX	MIN	MAX
A	0.415	0.425	10.54	10.79
B	0.415	0.425	10.54	10.79
C	0.212	0.230	5.38	5.84
D	0.038	0.042	0.96	1.07
G	0.100 BSC		2.54 BSC	
H	0.002	0.010	0.05	0.25
J	0.009	0.011	0.23	0.28
K	0.061	0.071	1.55	1.80
M	0°	7°	0°	7°
N	0.405	0.415	10.29	10.54
S	0.709	0.725	18.01	18.41

CASE 482-01
ISSUE O

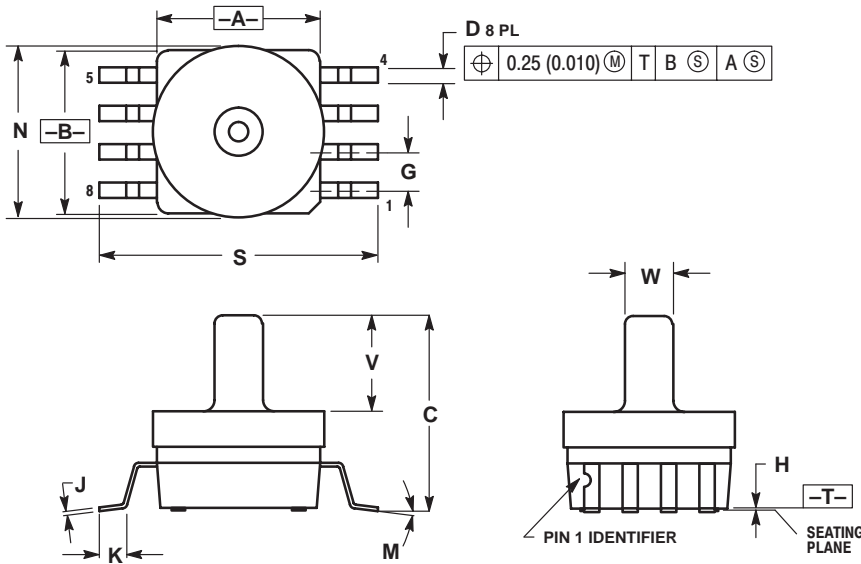

- NOTES:
1. DIMENSIONING AND TOLERANCING PER ANSI Y14.5M, 1982.
 2. CONTROLLING DIMENSION: INCH.
 3. DIMENSION A AND B DO NOT INCLUDE MOLD PROTRUSION.
 4. MAXIMUM MOLD PROTRUSION 0.15 (0.006).
 5. ALL VERTICAL SURFACES 5° TYPICAL DRAFT.

DIM	INCHES		MILLIMETERS	
	MIN	MAX	MIN	MAX
A	0.415	0.425	10.54	10.79
B	0.415	0.425	10.54	10.79
C	0.500	0.520	12.70	13.21
D	0.038	0.042	0.96	1.07
G	0.100 BSC		2.54 BSC	
H	0.002	0.010	0.05	0.25
J	0.009	0.011	0.23	0.28
K	0.061	0.071	1.55	1.80
M	0°	7°	0°	7°
N	0.444	0.448	11.28	11.38
S	0.709	0.725	18.01	18.41
V	0.245	0.255	6.22	6.48
W	0.115	0.125	2.92	3.17

CASE 482A-01
ISSUE A

SMALL OUTLINE PACKAGE DIMENSIONS – CONTINUED
SURFACE MOUNT

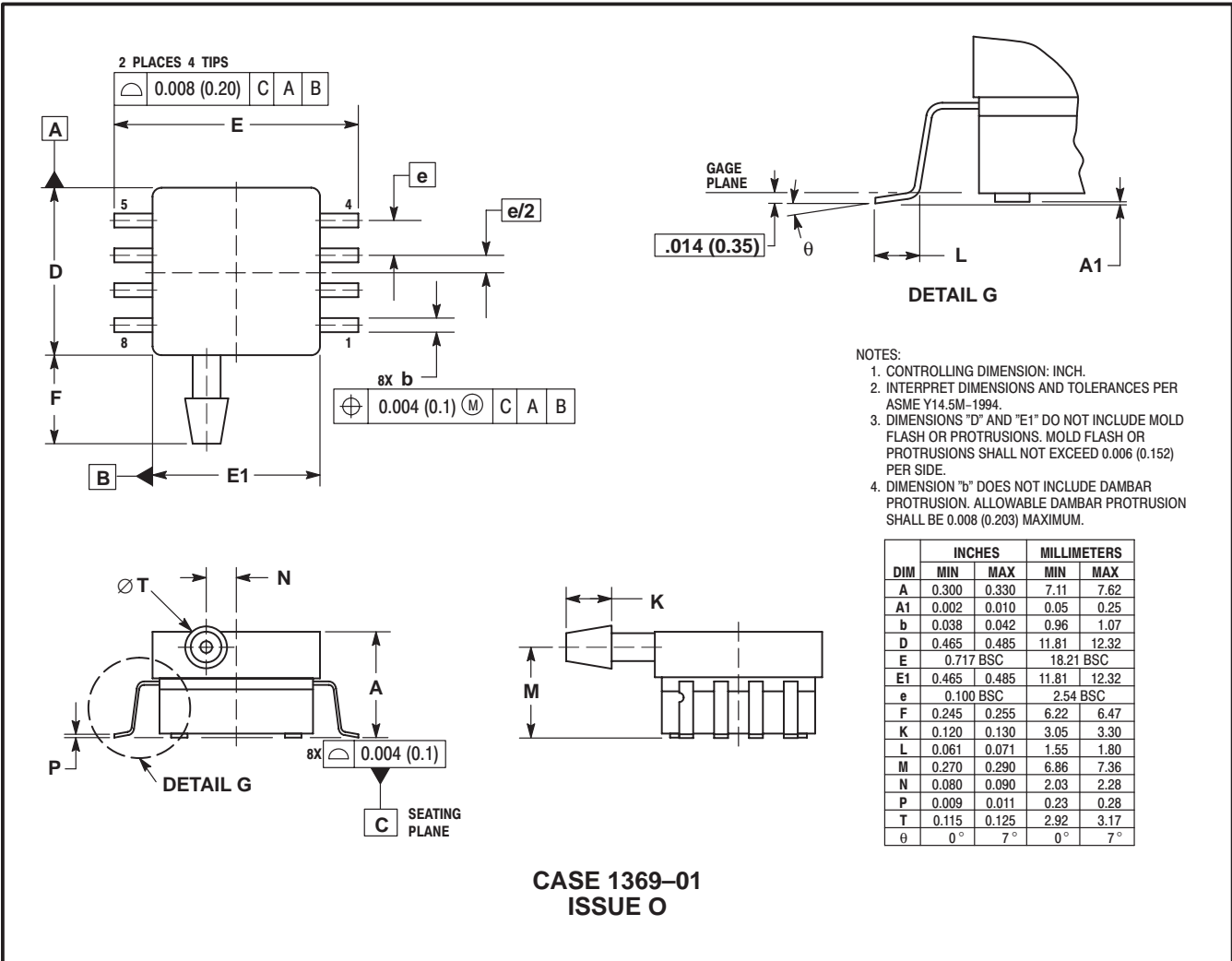

Freescale Semiconductor, Inc.

**SMALL OUTLINE PACKAGE DIMENSIONS – CONTINUED
SURFACE MOUNT**

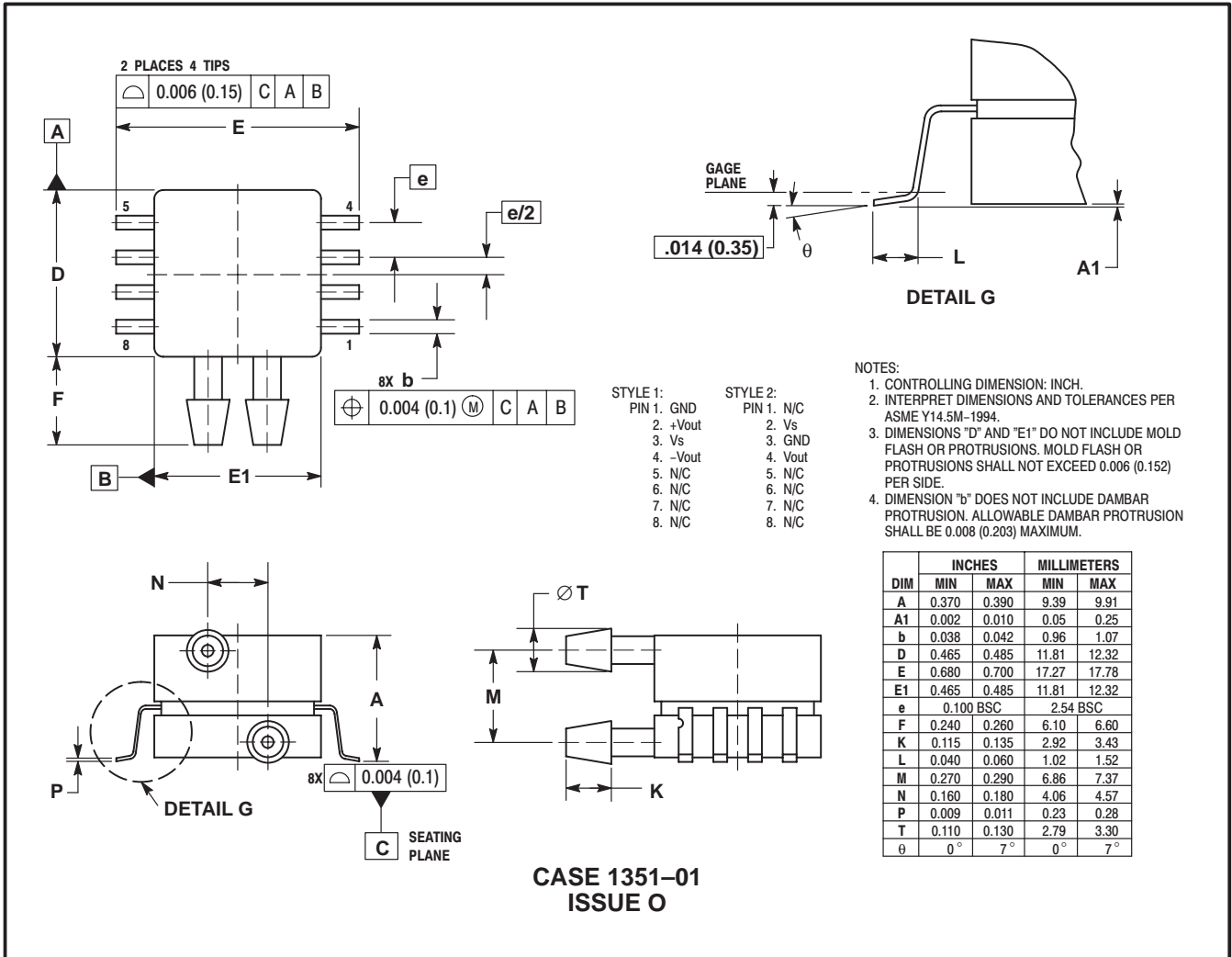

SMALL OUTLINE PACKAGE DIMENSIONS – CONTINUED
THROUGH-HOLE

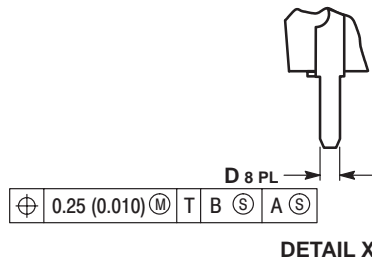
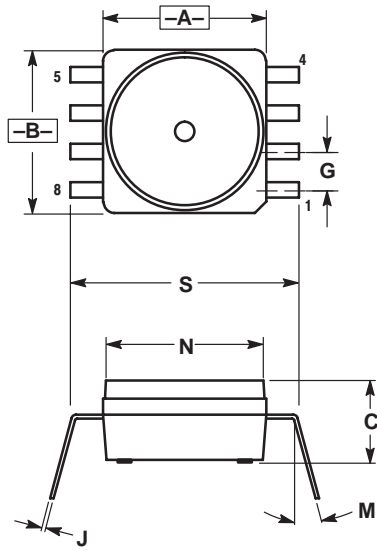

- NOTES:
1. DIMENSIONING AND TOLERANCING PER ANSI Y14.5M, 1982.
 2. CONTROLLING DIMENSION: INCH.
 3. DIMENSION A AND B DO NOT INCLUDE MOLD PROTRUSION.
 4. MAXIMUM MOLD PROTRUSION 0.15 (0.006).
 5. ALL VERTICAL SURFACES 5° TYPICAL DRAFT.
 6. DIMENSION S TO CENTER OF LEAD WHEN FORMED PARALLEL.

DIM	INCHES		MILLIMETERS	
	MIN	MAX	MIN	MAX
A	0.415	0.425	10.54	10.79
B	0.415	0.425	10.54	10.79
C	0.210	0.220	5.33	5.59
D	0.026	0.034	0.66	0.864
G	0.100 BSC		2.54 BSC	
J	0.009	0.011	0.23	0.28
K	0.100	0.120	2.54	3.05
M	0° 15°		0° 15°	
N	0.405	0.415	10.29	10.54
S	0.540	0.560	13.72	14.22

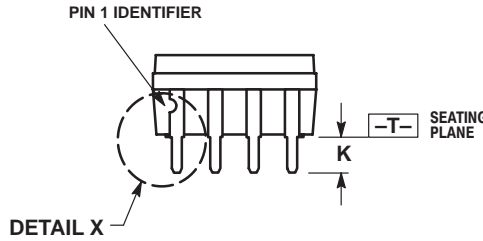

CASE 482B-03
ISSUE B

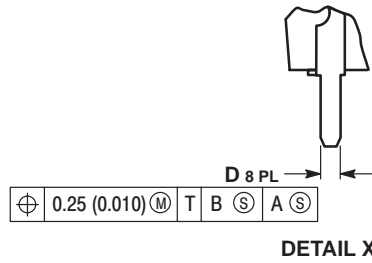
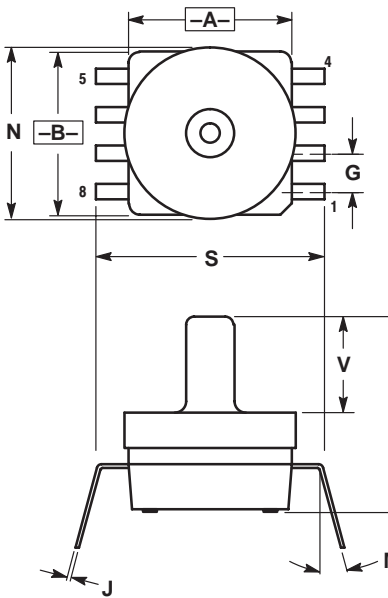

- NOTES:
1. DIMENSIONING AND TOLERANCING PER ANSI Y14.5M, 1982.
 2. CONTROLLING DIMENSION: INCH.
 3. DIMENSION A AND B DO NOT INCLUDE MOLD PROTRUSION.
 4. MAXIMUM MOLD PROTRUSION 0.15 (0.006).
 5. ALL VERTICAL SURFACES 5° TYPICAL DRAFT.
 6. DIMENSION S TO CENTER OF LEAD WHEN FORMED PARALLEL.

DIM	INCHES		MILLIMETERS	
	MIN	MAX	MIN	MAX
A	0.415	0.425	10.54	10.79
B	0.415	0.425	10.54	10.79
C	0.500	0.520	12.70	13.21
D	0.026	0.034	0.66	0.864
G	0.100 BSC		2.54 BSC	
J	0.009	0.011	0.23	0.28
K	0.100	0.120	2.54	3.05
M	0° 15°		0° 15°	
N	0.444	0.448	11.28	11.38
S	0.540	0.560	13.72	14.22
V	0.245	0.255	6.22	6.48
W	0.115	0.125	2.92	3.17

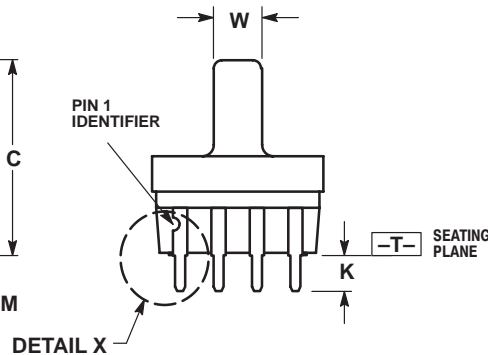

CASE 482C-03
ISSUE B

NOTES

Freescale Semiconductor, Inc.

NOTES

Freescale Semiconductor, Inc.

NOTES

Freescale Semiconductor, Inc.

Motorola reserves the right to make changes without further notice to any products herein. Motorola makes no warranty, representation or guarantee regarding the suitability of its products for any particular purpose, nor does Motorola assume any liability arising out of the application or use of any product or circuit, and specifically disclaims any and all liability, including without limitation consequential or incidental damages. "Typical" parameters can and do vary in different applications and actual performance may vary over time. All operating parameters, including "Typicals" must be validated for each customer application by customer's technical experts. Motorola does not convey any license under its patent rights nor the rights of others. Motorola products are not designed, intended, or authorized for use as components in systems intended for surgical implant into the body, or other applications intended to support or sustain life, or for any other application in which the failure of the Motorola product could create a situation where personal injury or death may occur. Should Buyer purchase or use Motorola products for any such unintended or unauthorized application, Buyer shall indemnify and hold Motorola and its officers, employees, subsidiaries, affiliates, and distributors harmless against all claims, costs, damages, and expenses, and reasonable attorney fees arising out of, directly or indirectly, any claim of personal injury or death associated with such unintended or unauthorized use, even if such claim alleges that Motorola was negligent regarding the design or manufacture of the part. Motorola and the Stylized M Logo are registered trademarks of Motorola, Inc. Motorola, Inc. is an Equal Opportunity/Affirmative Action Employer.

MOTOROLA and the Stylized M Logo are registered in the US Patent & Trademark Office. All other product or service names are the property of their respective owners.

© Motorola, Inc. 2002.

How to reach us:

USA/EUROPE/Locations Not Listed: Motorola Literature Distribution; P.O. Box 5405, Denver, Colorado 80217. 1-303-675-2140 or 1-800-441-2447

JAPAN: Motorola Japan Ltd.; SPS, Technical Information Center, 3-20-1, Minami-Azabu, Minato-ku, Tokyo 106-8573 Japan. 81-3-3440-3569

ASIA/PACIFIC: Motorola Semiconductors H.K. Ltd.; Silicon Harbour Centre, 2 Dai King Street, Tai Po Industrial Estate, Tai Po, N.T., Hong Kong. 852-26668334

Technical Information Center: 1-800-521-6274

HOME PAGE: <http://www.motorola.com/semiconductors/>



MOTOROLA

**For More Information On This Product,
Go to: www.freescale.com**

MPXV4006G/D