

DC/DC Converter – Power Supply 20 V

Description

The U6262B is a multifunctional power supply IC which provides four different voltages dedicated to supply components of complex microcontroller systems. Supplied by a battery voltage in the wide range from 6 V to 26 V, the U6262B generates typically 20 V with a step-up converter, PWM, external power MOSFET and 150 μ H inductivity. This voltage is fed to a step-down

converter with external 150 μ H inductivity to generate a 7-V auxiliary voltage with a small ripple. By means of this voltage, two linear regulators with only a small power dissipation provide a constant 5-V ($\pm 3\%$) supply for microcontrollers and an even more accurate 5-V ($\pm 2\%$) supply as a reference for sensors and a/d converters.

Features

- Voltage outputs
 - 20-V step-up converter with $I \leq 1.2$ A
 - 7-V step-down converter with $I \leq 400$ mA
 - 5-V logic supply with $I \leq 14$ mA
 - 5-V reference voltage with $I \leq 14$ mA
- Logic input ENABLE
 - Enables the step-up converter
- Analog input VKL15
 - Energy-reserve mode switches off the step-up converter at $V_{Batt} < 5.25$ V
 - Controls start-up behavior
- Logic output NRES
 - N-reset output with over/ under voltage monitoring of both 5-V supplies

Ordering Information

Extended Type Number	Package	Remarks
U6262B	SO20	

Block Diagram

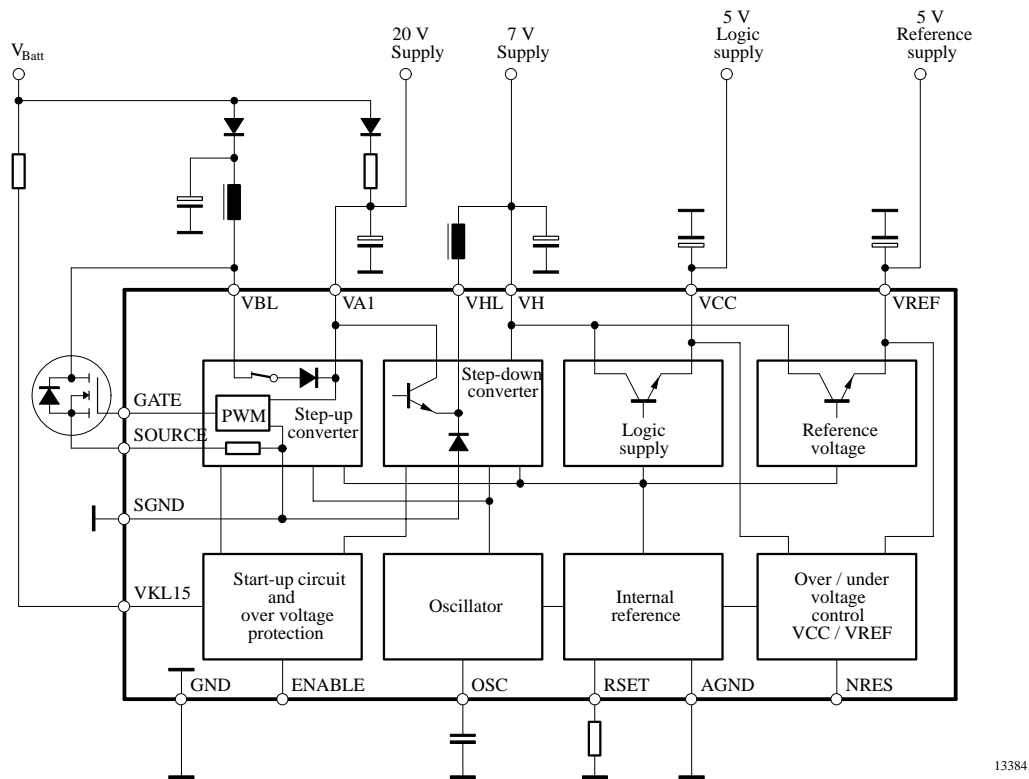

Figure 1. Block diagram with external circuit

13384

Ozone Depleting Substances Policy Statement

It is the policy of **TEMIC Semiconductor GmbH** to

1. Meet all present and future national and international statutory requirements.
2. Regularly and continuously improve the performance of our products, processes, distribution and operating systems with respect to their impact on the health and safety of our employees and the public, as well as their impact on the environment.

It is particular concern to control or eliminate releases of those substances into the atmosphere which are known as ozone depleting substances (ODSs).

The Montreal Protocol (1987) and its London Amendments (1990) intend to severely restrict the use of ODSs and forbid their use within the next ten years. Various national and international initiatives are pressing for an earlier ban on these substances.

TEMIC Semiconductor GmbH has been able to use its policy of continuous improvements to eliminate the use of ODSs listed in the following documents.

1. Annex A, B and list of transitional substances of the Montreal Protocol and the London Amendments respectively
2. Class I and II ozone depleting substances in the Clean Air Act Amendments of 1990 by the Environmental Protection Agency (EPA) in the USA
3. Council Decision 88/540/EEC and 91/690/EEC Annex A, B and C (transitional substances) respectively.

TEMIC Semiconductor GmbH can certify that our semiconductors are not manufactured with ozone depleting substances and do not contain such substances.

We reserve the right to make changes to improve technical design and may do so without further notice.

Parameters can vary in different applications. All operating parameters must be validated for each customer application by the customer. Should the buyer use TEMIC Semiconductors products for any unintended or unauthorized application, the buyer shall indemnify TEMIC Semiconductors against all claims, costs, damages, and expenses, arising out of, directly or indirectly, any claim of personal damage, injury or death associated with such unintended or unauthorized use.

TEMIC Semiconductor GmbH, P.O.B. 3535, D-74025 Heilbronn, Germany
Telephone: 49 (0)7131 67 2594, Fax number: 49 (0)7131 67 2423