

UTC LM2954 LINEAR INTEGRATED CIRCUIT

300 mA LOW-DROPOUT VOLTAGE REGULATOR

DESCRIPTION

The UTC LM2954 is a monolithic integrated voltage regulator with low dropout voltage, and low quiescent current. It includes many features that suitable for different applications.

Available in 3-pin TO-92, DIP-8, SOP-8 and SOT-223 packages.

FEATURES

- *High accuracy 3.3, 5V fixed output for TO-92, DIP-8 and SOP-8 package.
- *Extremely low quiescent current and dropout voltage.
- *Extremely tight load and line regulation.
- *Current and thermal limiting.
- *Very low temperature coefficient.
- *Logic controlled shutdown and error flag available for DIP and SOP package.
- *Output voltage programmable for DIP and SOP package.

APPLICATIONS

- *Battery powered equipment.
- *High efficient linear regulator down to 1.24V.
- *Cellular phones.

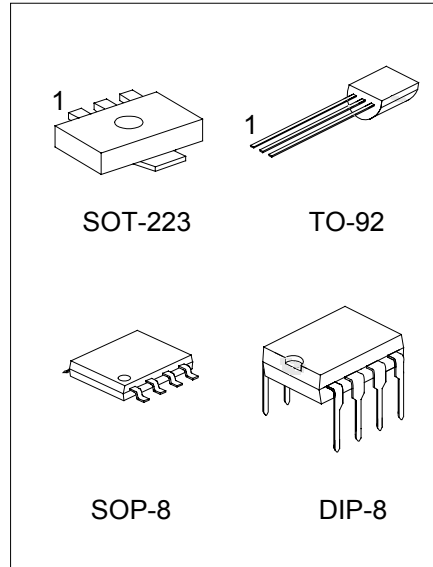

ORDERING INFORMATION

PART NUMBER	TEMPERATURE RANGE	PACKAGE	ACCURACY
UTC LM2954-5.0	-40°C ~ +125°C	3-Pin TO-92 plastic	1.0%
UTC LM2954-3.3	-40°C ~ +125°C	3-Pin TO-92 plastic	1.0%
UTC LM2954	-40°C ~ +125°C	8-Pin SOP-8 plastic	1.0%
UTC LM2954	-40°C ~ +125°C	8-Pin DIP-8 plastic	1.0%

UTC LM2954 LINEAR INTEGRATED CIRCUIT

PIN CONFIGURATIONS

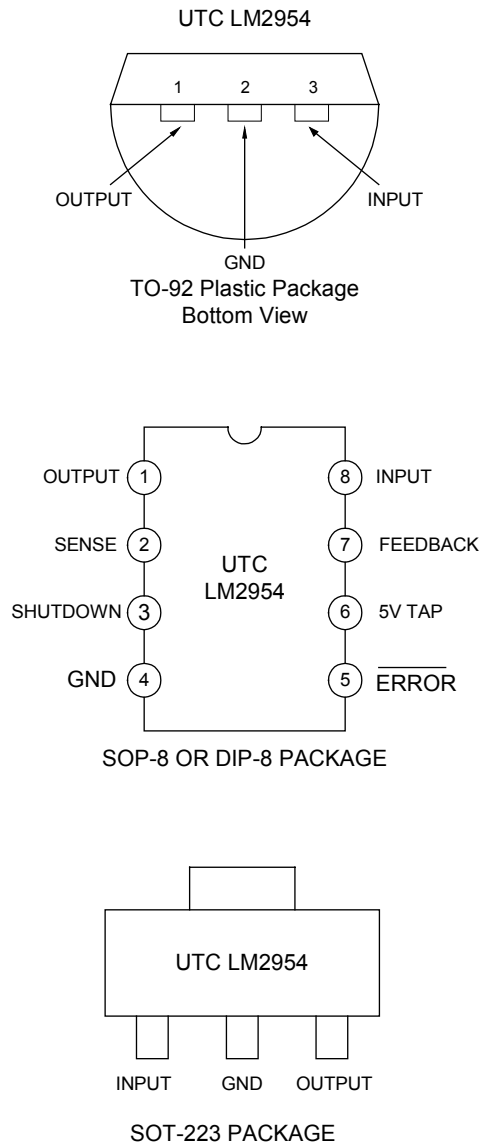
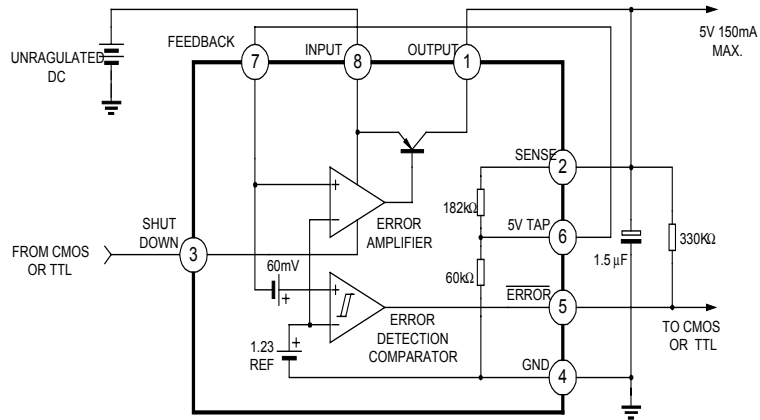

Fig. 1

UTC LM2954 LINEAR INTEGRATED CIRCUIT

BLOCK DIAGRAM



ABSOLUTE MAXIMUM RATINGS

PARAMETER	SYMBOL	VALUE	UNIT
Supply Voltage	V _{cc}	-0.3 ~ +30	V
Feedback Voltage	V _{feedback}	-1.5 ~ +30	V
Shutdown Voltage	V _{shutdown}	-0.3 ~ +30	V
Comparator Output Voltage	V _{co}	-0.3 ~ +30	V
Storage temperature	T _{str}	-65 ~ +150	°C
Operating Junction Temperature	T _j	-40 ~ +125	°C

UTC LM2954 LINEAR INTEGRATED CIRCUIT

ELECTRICAL CHARACTERISTICS

(Tested at $T_J=25^{\circ}\text{C}$, $V_{IN}=6\text{V}$, $I_L=100\mu\text{A}$ and $C_L=1\text{F}$, unless otherwise specified)

PARAMETER	PART NUMBER	TEST CONDITIONS	MIN.	TYP.	MAX.	UNIT
Output Voltage	UTC LM2954-3.3 UTC LM2954-5.0 UTC LM2954	$T_J=25^{\circ}\text{C}$ (note 1)	3.27 4.95	3.3 5.0	3.33 5.05	V
	UTC LM2954-3.3 UTC LM2954-5.0 UTC LM2954	$-25^{\circ}\text{C}\leq T_J\leq +85^{\circ}\text{C}$ (note 1)	3.23 4.9	3.3 5.0	3.36 5.1	V
	UTC LM2954-3.3 UTC LM2954-5.0 UTC LM2954	$100\mu\text{A}\leq I_L\leq 300\text{mA}$ $T_J\leq T_J(\text{max})$ (note 1)	3.23 4.9	3.3 5.0	3.36 5.1	V
Output Voltage Temperature Coefficient			20		100	ppm/ $^{\circ}\text{C}$
Line Regulation		$6\text{V}\leq V_{IN}\leq 30\text{V}$		0.1	0.2	%
Load Regulation		$100\mu\text{A}\leq I_L\leq 300\text{mA}$		0.2	0.5	%
Dropout Voltage		$I_L=100\text{mA}$	50	80	150	mV
		$I_L=200\text{mA}$ (note 2)	380	450	600	
Ground Current		$I_L=100\mu\text{A}$	0.75	0.12	0.14	mA
		$I_L=200\text{mA}$	8	12	14	
Dropout Ground Current		$V_{IN}=4.5\text{V}$, $I_L=100\mu\text{A}$	110	170	200	μA
Current Limit		$V_{out}=0$	300			mA
Output Noise 10Hz to 100KHz		$C_L=1\mu\text{F}$			430	μV
		$C_L=200\mu\text{F}$			160	
		$C_L=3.3\mu\text{F}$			100	
		(Bypass=0.01 μF) pins 7 to (utc2954)				
For 8-Pin Version Only						
Reference Voltage			1.22	1.235	1.25	V
Reference Voltage		(Note 4)	1.19		1.27	V
Feedback Pin Bias Current				20	40	nA
Reference Voltage Temperature Coefficient				50		ppm/ $^{\circ}\text{C}$
Feedback Bias Current Temperature Coefficient				0.1		nA/ $^{\circ}\text{C}$
Error Comparator						
Output Leakage Current		$V_{OH}=30\text{V}$			1	μA
Output Low Voltage		$V_{IN}=4.5\text{V}$ $I_{OL}=400\mu\text{A}$			250	mV
Upper Threshold Voltage		(Note 3)	3.2			% V_O
Lower Threshold Voltage		(Note 3)			7.6	% V_O
Hysteresis		(Note 3)		15		mV
Shutdown Input						

UTC LM2954 LINEAR INTEGRATED CIRCUIT

PARAMETER	PART NUMBER	TEST CONDITIONS	MIN.	TYP.	MAX.	UNIT
Input Logic Voltage		Low(Regulator ON)		1.3		V
		High(Regulator OFF)	2.0		0.70	
Shutdown Pin Input Current		Vshutdown=2.4V		30	50	μA
		Vshutdown=30V		450	600	μA
Regulator Output Current Shutdown		Vshutdown>=2V, VIN<=30V, Vout=0, Feedback pin tied to 5V Tap.		3	10	μA

Note 1: Additional conditions for 8-pin versions are feedback tied to 5V Tap an Output tied to Output Sense (Vout=5V) and Vshutdown<=0.8V.

Note 2: Dropout Voltage is defined as the input to output differential at which the output voltage drops 100mV below its nominal value measured at 1V differential.

Note 3: Comparator thresholds are expressed in terms of percentage value of voltage output.

Note 4: $V_{ref} \leq V_{out} \leq (V_{in} - 1V)$, $2.3V \leq V_{in} \leq 30V$, $100\mu A \leq I_L \leq 100mA$, $T_J \leq T_{JMAX}$

APPLICATION CIRCUIT (10A LOW DROPOUT REGULATOR)

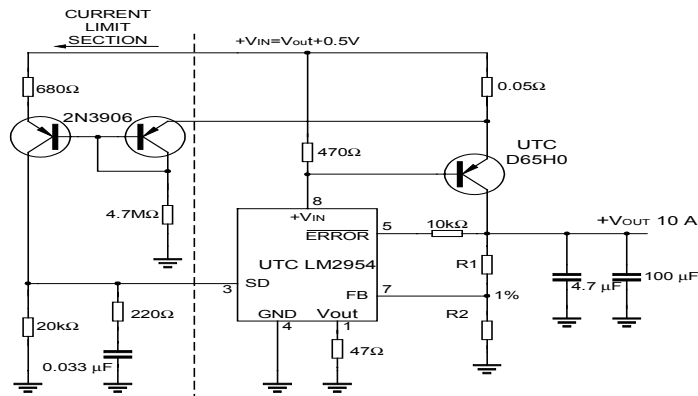

$$V_{out} = 1.23V * (1 + R1/R2)$$

For 5V output use internal resistors. Wire pin 6 to 7 and wire pin 2 to +Vout

Fig.2

UTC LM2954 LINEAR INTEGRATED CIRCUIT

