

ADVANCE PRODUCT SUMMARY

# CX77312: iPAC™ PAM for Quad-Band GSM / GPRS

## APPLICATIONS

- Quad-band cellular handsets encompassing
  - Class 4 GSM850/900
  - Class 1 DCS1800 PCS1900
  - Class 12 GPRS multi-slot operation

## FEATURES

- Low input power range 0 to 6 dBm
- High efficiency
  - GSM850 53%
  - GSM900 54%
  - DCS 49%
  - PCS 49%
- Internal ICC sense resistor for iPAC™
- Closed loop iPAC or open loop operation with external PAC circuit
- Input/Output matching 50 Ω internal (with DC blocking)
- Small outline
  - 8 mm x 10 mm
- Low profile
  - 1.5 mm maximum
- Low APC current
  - 25 μA
- Gold plated, lead-free contacts

The CX77312 Power Amplifier Module (PAM) is designed in a compact form factor for quad-band cellular handsets comprising GSM850/900, DCS1800, and PCS1900 operation. The PAM also supports Class 12 General Packet Radio Service (GPRS) multi-slot operation.

The module consists of separate GSM850/900 PA and DCS1800/PCS1900 PA blocks, impedance-matching circuitry for 50 Ω input and output impedances, and a Power Amplifier Control (PAC) block with an internal current-sense resistor. The custom CMOS integrated circuit provides the internal PAC function and interface circuitry. Fabricated onto a single Gallium Arsenide (GaAs) die, one Heterojunction Bipolar Transistor (HBT) PA block supports the GSM850/900 bands and the other supports the DCS1800 and PCS1900 bands. Both PA blocks share common power supply pins to distribute current. The GaAs die, the Silicon (Si) die, and the passive components are mounted on a multi-layer laminate substrate. The assembly is encapsulated with plastic overmold.

RF input and output ports of the CX77312 are internally matched to 50 Ω to reduce the number of external components for a quad-band design. Extremely low leakage current (2.5 mA, typical) of the dual PA module maximizes handset standby time. The CX77312 also contains band-select switching circuitry to select GSM (logic 0) or DCS/PCS (logic 1) as determined from the Band Select (BS) signal. In the Functional Block Diagram below, the BS pin selects the PA output (DCS/PCS OUT or GSM OUT) and the Analog Power Control (VAPC) controls the level of output power.

VBATT and IREG OUT pins connect to an internal current-sense resistor and interface to an integrated power amplifier control (PAC) function, which is insensitive to variations in temperature, power supply, and process. The PAC ENABLE input allows initial turn-on of PAC circuitry to minimize battery drain.

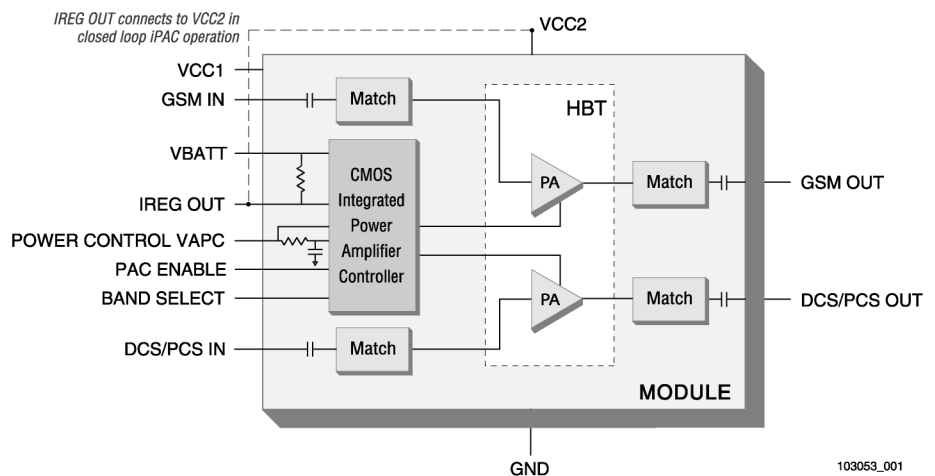

Figure 1. Functional Block Diagram

© 2002–2003, Skyworks Solutions, Inc. All Rights Reserved.

Information in this document is provided in connection with Skyworks Solutions, Inc. ("Skyworks") products. These materials are provided by Skyworks as a service to its customers and may be used for informational purposes only. Skyworks assumes no responsibility for errors or omissions in these materials. Skyworks may make changes to its products, specifications and product descriptions at any time, without notice. Skyworks makes no commitment to update the information and shall have no responsibility whatsoever for conflicts, incompatibilities, or other difficulties arising from future changes to its products and product descriptions.

No license, express or implied, by estoppel or otherwise, to any intellectual property rights is granted by this document. Except as may be provided in Skyworks' Terms and Conditions of Sale for such products, Skyworks assumes no liability whatsoever.

THESE MATERIALS ARE PROVIDED "AS IS" WITHOUT WARRANTY OF ANY KIND, EITHER EXPRESS OR IMPLIED, RELATING TO SALE AND/OR USE OF SKYWORKS™ PRODUCTS INCLUDING WARRANTIES RELATING TO FITNESS FOR A PARTICULAR PURPOSE, MERCHANTABILITY, PERFORMANCE, QUALITY OR NON-INFRINGEMENT OF ANY PATENT, COPYRIGHT OR OTHER INTELLECTUAL PROPERTY RIGHT. SKYWORKS FURTHER DOES NOT WARRANT THE ACCURACY OR COMPLETENESS OF THE INFORMATION, TEXT, GRAPHICS OR OTHER ITEMS CONTAINED WITHIN THESE MATERIALS. SKYWORKS SHALL NOT BE LIABLE FOR ANY SPECIAL, INDIRECT, INCIDENTAL, OR CONSEQUENTIAL DAMAGES, INCLUDING WITHOUT LIMITATION, LOST REVENUES OR LOST PROFITS THAT MAY RESULT FROM THE USE OF THESE MATERIALS.

Skyworks™ products are not intended for use in medical, lifesaving or life-sustaining applications. Skyworks' customers using or selling Skyworks™ products for use in such applications do so at their own risk and agree to fully indemnify Skyworks for any damages resulting from such improper use or sale.

The following are trademarks of Skyworks Solutions, Inc.: Skyworks™, the Skyworks symbol, and "Breakthrough Simplicity"™. Product names or services listed in this publication are for identification purposes only, and may be trademarks of third parties. Third-party brands and names are the property of their respective owners.

Additional information, posted at [www.skyworksinc.com](http://www.skyworksinc.com), is incorporated by reference.

General Information  
Skyworks Solutions, Inc.  
20 Sylvan Rd.  
Woburn, MA 01801

[www.skyworksinc.com](http://www.skyworksinc.com)

