

1.4MHz SOT23 Current-Mode Step-Up DC/DC Converter

FEATURES

- Fixed Frequency 1.4MHz Current-Mode PWM Operation.
- Adjustable Output Voltage up to 30V.
- Guaranteed 13V/ 200mA Output with 5V Input.
- 2.5V to 10V Input Range.
- Maximum 0.1 μ A Shutdown Current.
- Programmable Soft-Start.
- Tiny Inductor and Capacitors are allowed.
- Space-Saving SOT-23-6 Package.

APPLICATIONS

- White LED Backlight.
- OLED Driver.

DESCRIPTION

AIC1896 is a current-mode pulse-width modulation (PWM), step-up DC/DC Converter. The built-in high voltage N-channel MOSFET allows AIC1896 for step-up applications with up to 30V output voltage, as well as for Single Ended Primary Inductance Converter (SEPIC) and other low-side switching DC/DC converter.

The high switching frequency (1.4MHz) allows the use of small external components. The Soft-Start function is programmable with an external capacitor, which sets the input current ramp rate.

The AIC1896 is available in a space-saving SOT-23-6 package.

TYPICAL APPLICATION CIRCUIT

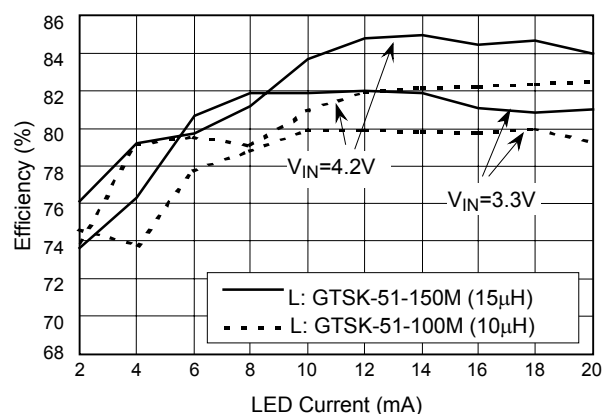
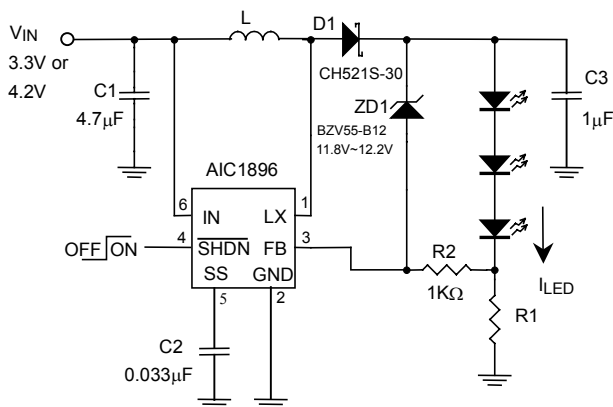

Fig. 1 Li-Ion Powered Driver for three white LEDs

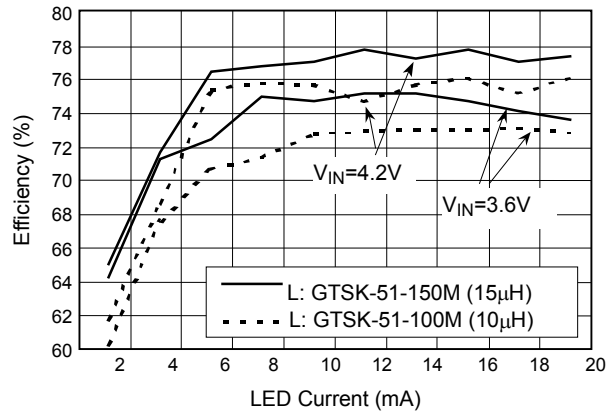
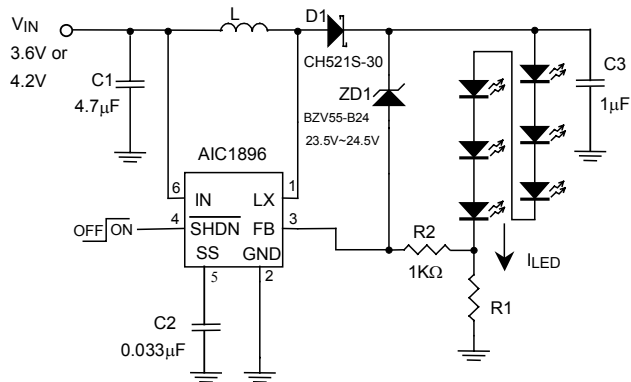

Fig. 2 Li-Ion Powered Driver for six white LEDs

ORDERING INFORMATION

AIC1896-CXXX

PACKING TYPE
 TR: TAPE & REEL
 BG: BAG

PACKAGE TYPE
 G: SOT-23-6

Example: AIC1896-CGTR
 → in SOT-23-6 Package & Tape & Reel
 Packing Type

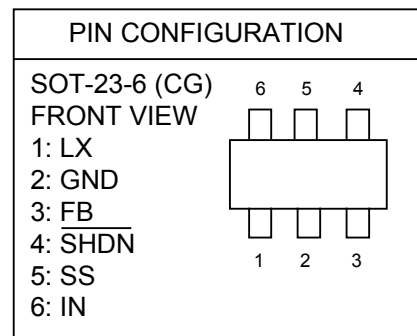

● SOT-23-6 Marking

Part No.	Marking
AIC1896CG	1896

■ ABSOLUTE MAXIMUM RATINGS

LX to GND	-0.3V to +33V
FB to GND	-0.3V to +6V
IN, $\overline{\text{SHDN}}$	-0.3V to +11V
SS to GND	-0.3V to +6V
LX Pin RMS Current	0.6A
Continuous Power Dissipation ($T_A = +70^\circ\text{C}$) (Note 1)	
6-Pin SOT23 (derate 9.1mW/ $^\circ\text{C}$ above +70 $^\circ\text{C}$)	727mW
Operating Temperature Range	-40 $^\circ\text{C}$ to +85 $^\circ\text{C}$
Junction Temperature	+150 $^\circ\text{C}$
Storage Temperature Range	-65 $^\circ\text{C}$ to +150 $^\circ\text{C}$
Lead Temperature (soldering, 10s)	+300 $^\circ\text{C}$

Note 1: Thermal properties are specified with product mounted on PC board with one square-inch of copper area and still air.

ELECTRICAL CHARACTERISTICS ($V_{IN}=V_{SHDN}=3V$, $FB=GND$, $SS=Open$, $T_A=-40^{\circ}C$

 to $85^{\circ}C$, Unless otherwise specified)

PARAMETER	SYMBOL	CONDITIONS	MIN	TYP	MAX	UNITS
Input Supply Range	V_{IN}		2.5		10	V
Output Voltage Adjust Range	V_{OUT}				30	V
V_{IN} Undervoltage Lockout	UVLO	V_{IN} rising, 50mV hysteresis		2.2		V
Quiescent Current	I_{IN}	$V_{FB} = 1.3V$, not switching		0.1	0.2	mA
		$V_{FB} = 1.0V$, switching		1	5	
Shutdown Supply Current		$\overline{V_{SHDN}} = 0$, $T_A = +25^{\circ}C$		0.01	0.5	μA
		$\overline{V_{SHDN}} = 0$		0.01	10	μA
ERROR AMPLIFIER						
Feedback Regulation Set Point	V_{FB}		1.205	1.23	1.255	V
FB Input Bias Current	I_{FB}	$V_{FB} = 1.24V$		21	80	nA
Line Regulation		$2.6V < V_{IN} < 5.5V$		0.05	0.20	%/V
OSCILLATOR						
Frequency	f_{OSC}		1000	1400	1800	KHz
Maximum Duty Cycle	DC		82	86		%
POWER SWITCH						
Steady State Output Current	I_o	Refer to Fig. 18				A
On-Resistance	$R_{DS(ON)}$			1	1.4	Ω
Leakage Current	$I_{LX(OFF)}$	$V_{LX} = 12V$, $T_A = +25^{\circ}C$		0.1	1	μA
		$V_{LX} = 12V$			10	
SOFT-START						
Reset Switch Resistance					100	Ω
Charge Current		$V_{SS} = 1.2V$	1.5	4	7.0	μA
CONTROL INPUT						
Input Low Voltage	V_{IL}	$\overline{V_{SHDN}}$, $V_{IN} = 2.5V$ to $10V$			0.3	V
Input High Voltage	V_{IH}	$\overline{V_{SHDN}}$, $V_{IN} = 2.5V$ to $10V$	1.0			V
\overline{SHDN} Input Current	$I_{\overline{SHDN}}$	$\overline{V_{SHDN}} = 3V$		25	50	μA
		$\overline{V_{SHDN}} = 0$		0.01	0.1	

TYPICAL PERFORMANCE CHARACTERISTICS

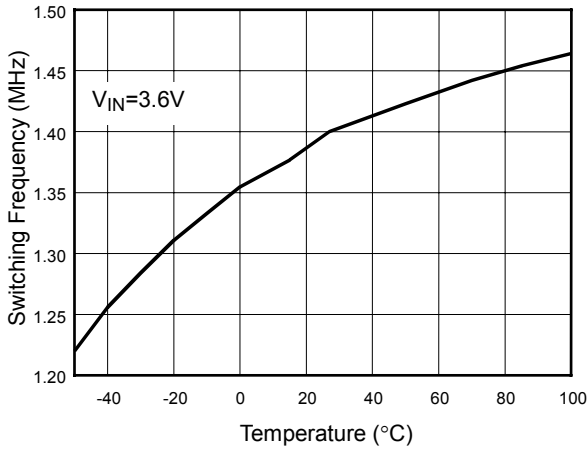

Fig. 3 Switching Frequency vs. Temperature

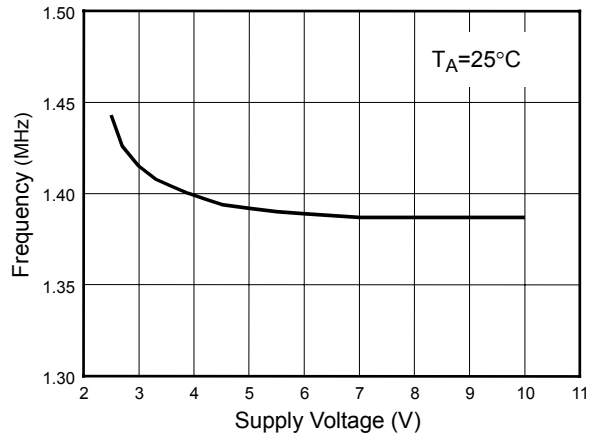

Fig. 4 Frequency vs. Supply Voltage

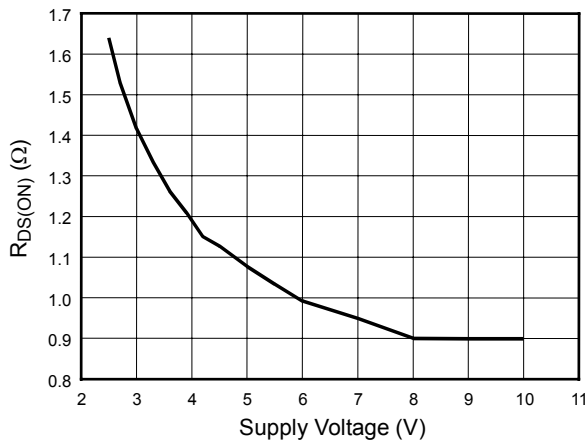

Fig. 5 R_DS(ON) vs. Supply Voltage

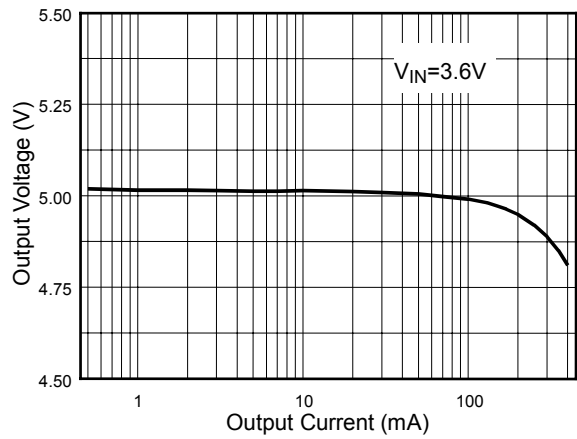

Fig. 6 Load Regulation

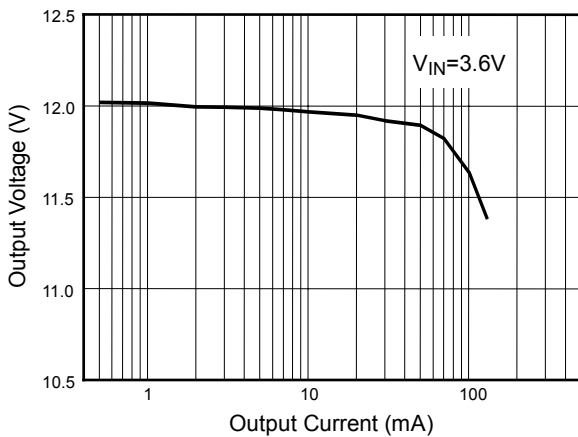

Fig. 7 Load Regulation

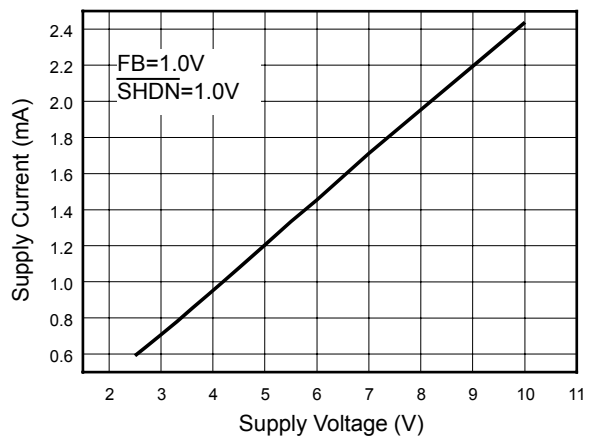

Fig. 8 Load Regulation

TYPICAL PERFORMANCE CHARACTERISTICS (Continued)

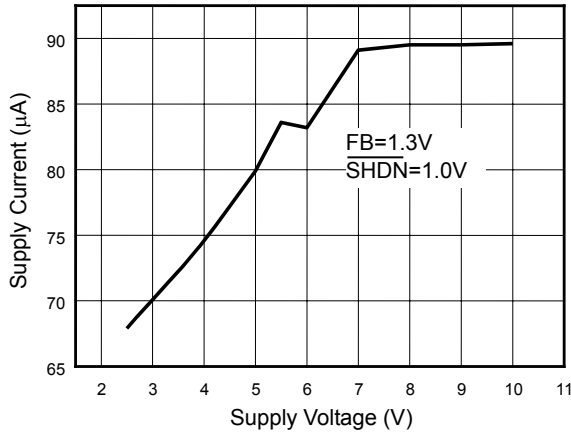

Fig. 9 Non-Switching Current

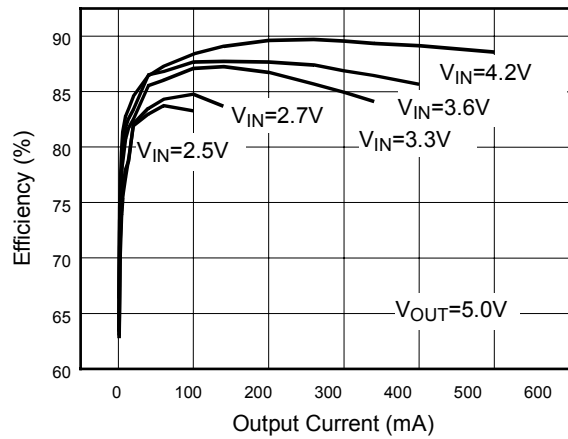

Fig. 10 Efficiency vs. Output Current

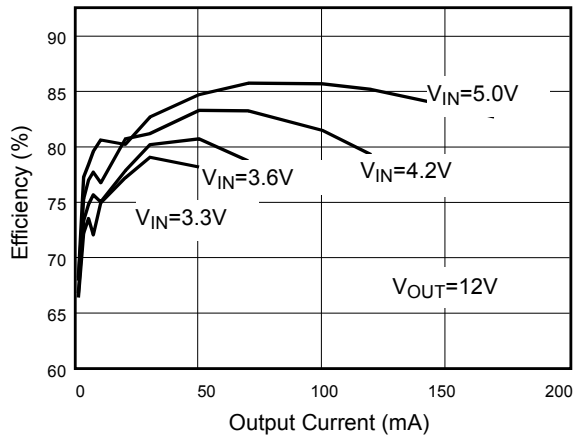

Fig. 11 Efficiency vs. Output Current

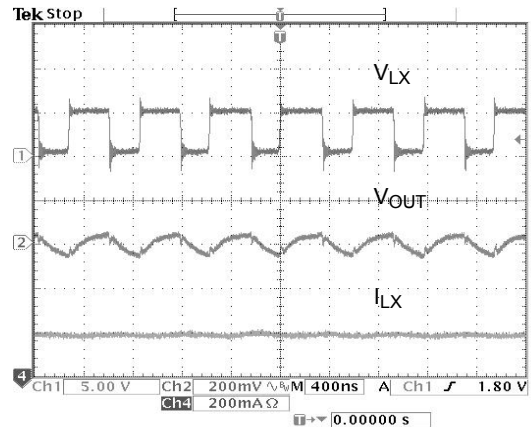

Fig. 12 Operation Wave Form

($V_{IN}=3V; V_{OUT}=5V; L1=10\mu H; R1=36K; R2=12K;$
 $C3=39pF; I_{OUT}=200mA$)

TYPICAL PERFORMANCE CHARACTERISTICS (Continued)

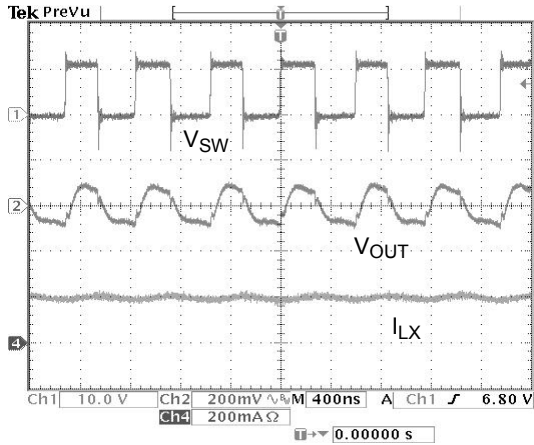

Fig. 13 Operation Wave Form
 $(V_{IN}=5V; V_{OUT}=12V; L1=22\mu H; R1=105K;$
 $R2=12K; C3=1nF; I_{OUT}=200mA)$

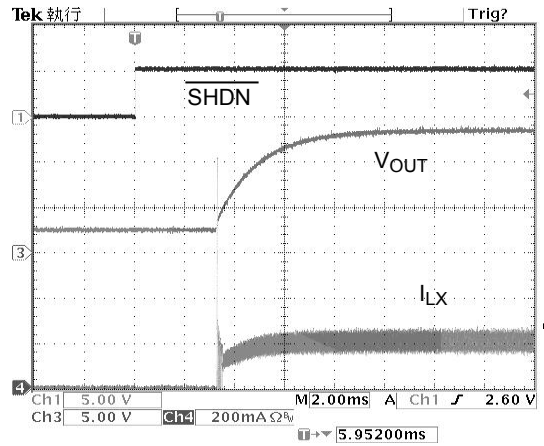

Fig. 14 Start-Up from Shutdown
 $(V_{IN}=3.3V; V_{OUT}=13V; R_{LOAD}=300\Omega)$

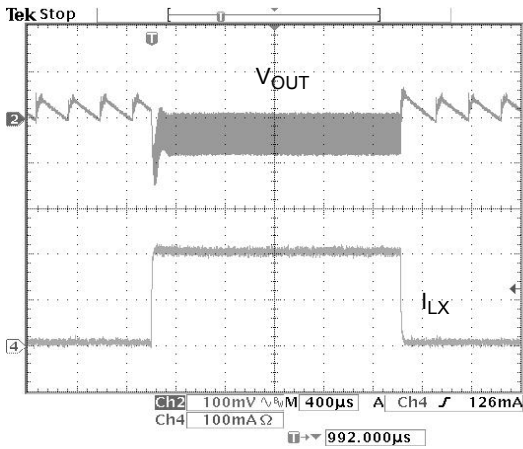

Fig. 15 Load Step Response
 $(V_{IN}=3.3V; V_{OUT}=5V; I_{OUT}=5mA \text{ to } 200mA)$

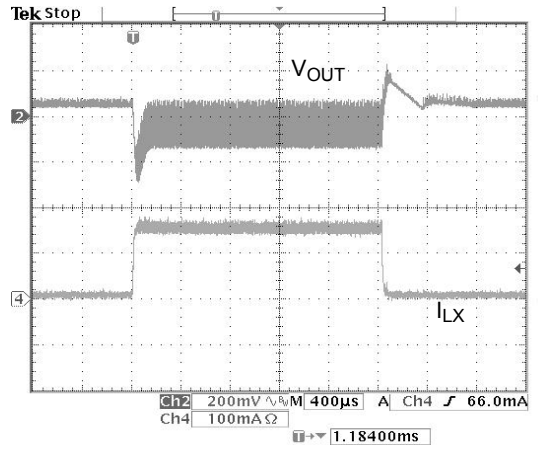

Fig. 16 Load Step Response
 $(V_{IN}=5V; V_{OUT}=12V; I_{OUT}=5mA \text{ to } 150mA)$

■ TYPICAL PERFORMANCE CHARACTERISTICS (Continued)

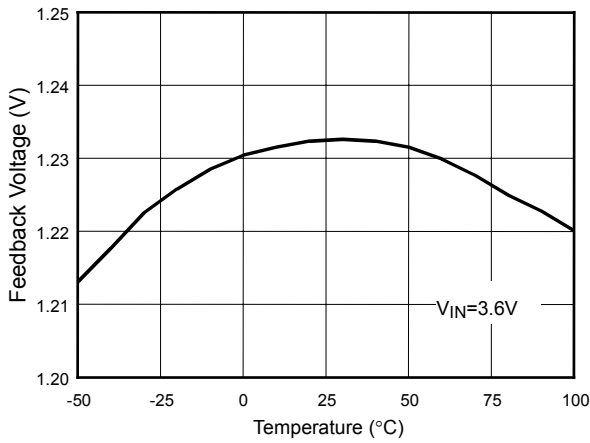

Fig. 17 Feedback Pin Voltage

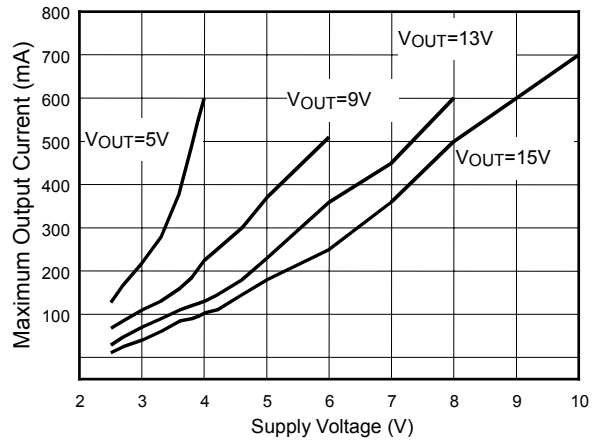

Fig. 18 Maximum Output current vs. Supply Voltage

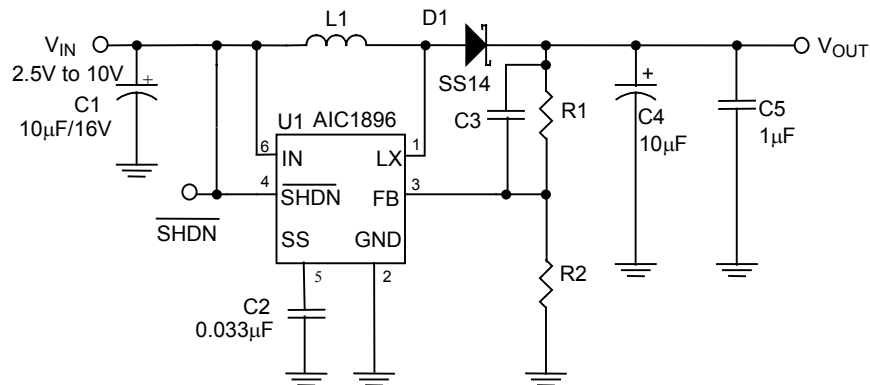
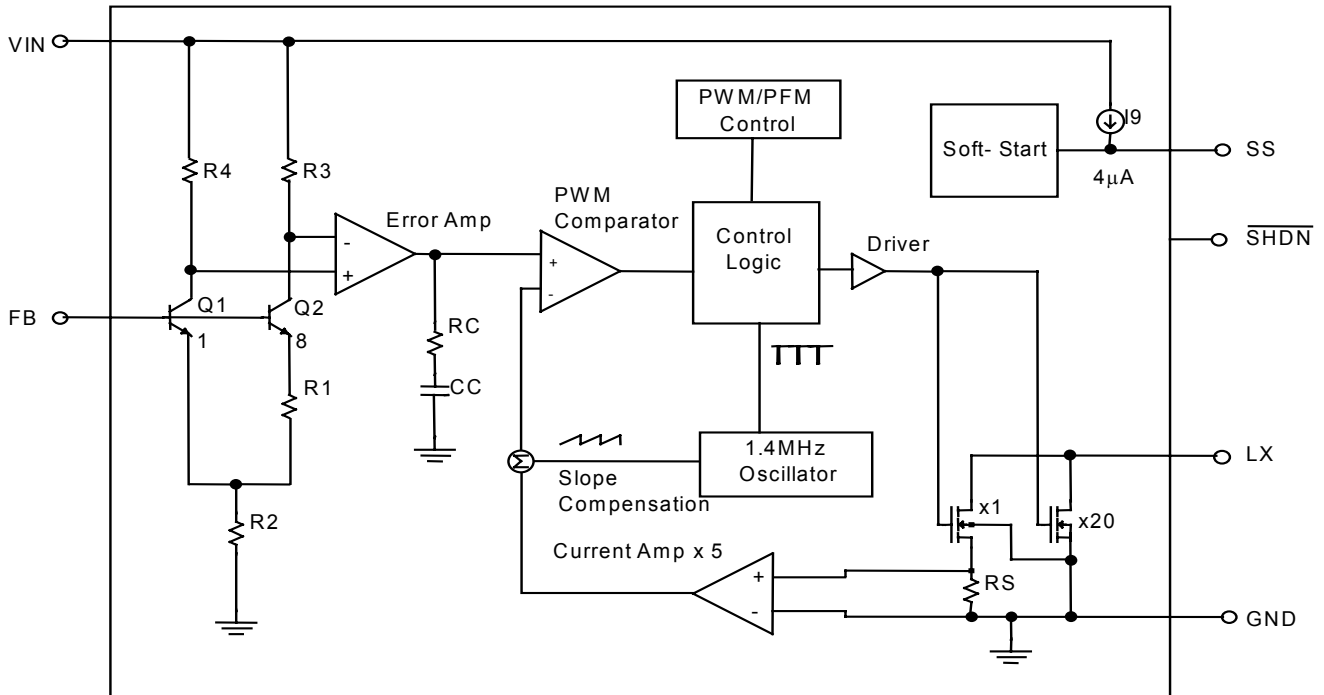

Fig. 19. Test circuit of figure 9~18.

■ BLOCK DIAGRAM



■ PIN DESCRIPTIONS

PIN 1: LX - Power Switching Connection. Connect LX to inductor and output rectifier. Keep the distance between the components as close to LX as possible.

PIN 2: GND - Ground.

PIN 3: FB - Feedback Input. Connect a resistive voltage-divider from the output to FB to set the output voltage.

PIN 4: $\overline{\text{SHDN}}$ - Shutdown Input. Drive $\overline{\text{SHDN}}$ low to turn off the converter. To automatically start the converter, connect $\overline{\text{SHDN}}$ to IN. Drive

$\overline{\text{SHDN}}$ with a slew rate of $0.1\text{V}/\mu\text{s}$ or greater. Do not leave $\overline{\text{SHDN}}$ unconnected. $\overline{\text{SHDN}}$ draws up to $50\mu\text{A}$.

PIN 5: SS - Soft-Start Input. Connect a soft-start capacitor from SS to GND in order to soft-start the converter. Leave SS open to disable the soft-start function.

PIN 6: IN - Internal Bias Voltage Input. Connect IN to the input voltage source. Bypass IN to GND with a capacitor sitting as close to IN as possible.

■ APPLICATION INFORMATION

Inductor Selection

A 15 μ H inductor is recommended for most AIC1896 applications. Although small size and high efficiency are major concerns, the inductor should have low core losses at 1.4MHz and low DCR (copper wire resistance).

Capacitor Selection

The small size of ceramic capacitors makes them ideal for AIC1896 applications. X5R and X7R types are recommended because they retain their capacitance over wider ranges of voltage and temperature than other types, such as Y5V or Z5U. A 4.7 μ F input capacitor and a 1 μ F output capacitor are sufficient for most AIC1896 applications.

Diode Selection

Schottky diodes, with their low forward voltage drop and fast reverse recovery, are the ideal choices for AIC1896 applications. The forward voltage drop of a Schottky diode represents the conduction losses in the diode, while the diode capacitance (CT or CD) represents the switching losses. For diode selection, both forward voltage drop and diode capacitance need to be considered. Schottky diodes with higher current ratings usually have lower forward voltage drop and larger diode capacitance, which can cause significant switching losses at the 1.4MHz switching frequency of AIC1896. A Schottky diode rated at 100mA to 200mA is sufficient for most AIC1896 applications.

LED Current Control

LED current is controlled by feedback resistor (R1 in Fig. 1). The feedback reference is 1.23V. The LED current is $1.23V/R1$. In order to have

accurate LED current, precision resistors are preferred (1% recommended). The formula for R1 selection are shown below.

$$R1 = 1.23V/I_{LED} \quad (1)$$

Open-Circuit Protection

In the cases of output open circuit, when the LEDs are disconnected from the circuit or the LEDs fail, the feedback voltage will be zero. AIC1896 will then switch to a high duty cycle resulting in a high output voltage, which may cause SW pin voltage to exceed its maximum 30V rating. A zener diode can be used at the output to limit the voltage on SW pin (Fig. 20). The zener voltage should be larger than the maximum forward voltage of the LED string. The current rating of the zener should be larger than 0.1mA.

Dimming Control

There are three different types of dimming control circuits as follows:

1. Using a pwm signal

PWM brightness control provides the widest dimming range by pulsing the LEDs on and off using the control signal. The LEDs operate at either zero or full current, The average LED current changes with the duty cycle of the PWM signal. Typically, a 1kHz to 10kHz PWM signal is used. PWM dimming with the AIC1896 can be accomplished two different ways (see Fig. 21). The $\overline{\text{SHDN}}$ pin can be driven directly or a resistor can be added to drive the FB pin. If the $\overline{\text{SHDN}}$ pin is used, increasing the duty cycle will increase the LED brightness. If the FB pin is used, increasing the duty cycle will decrease the brightness. Using this method, the LEDs are dimmed using FB and turned off completely using $\overline{\text{SHDN}}$.

2. Using a DC Voltage

For some applications, the preferred method of brightness control uses a variable DC voltage to adjust the LED current. The dimming control using a DC voltage is shown in Fig. 22. As the DC voltage increases, the voltage drop on R2 increases and the voltage drop on R1 decreases. Thus, the LED current decreases. The selection of R2 and R3 should make the current from the variable DC source much smaller than the LED current and much larger than the FB pin bias

current. For VDC range from 0V to 5V, the selection of resistors in Fig. 22 gives dimming control of LED current from 20mA to 0mA.

3. Using a Filtered PWM Signal

The filtered PWM signal can be considered as an adjustable DC voltage. It can be used to replace the variable DC voltage source in dimming control. The circuit is shown in Fig. 23.

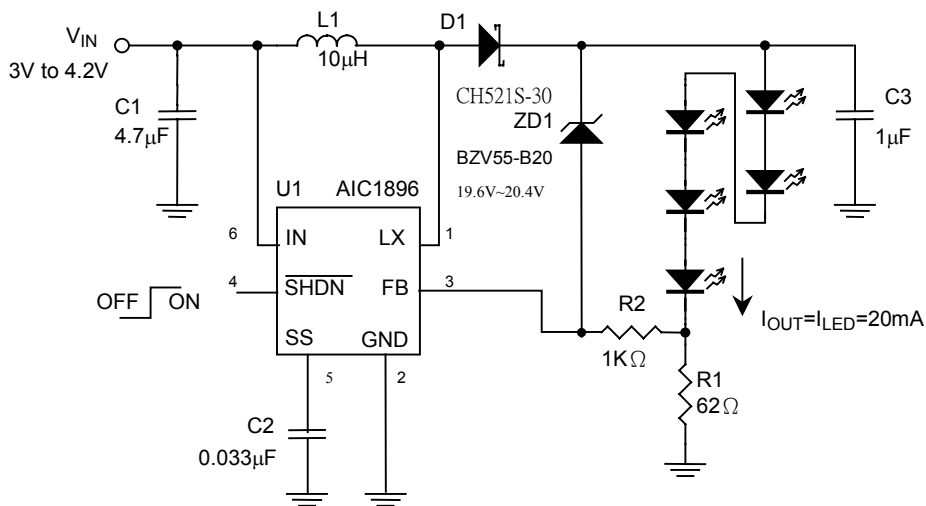

Fig. 20 White LED Driver with Open-Circuit Protection

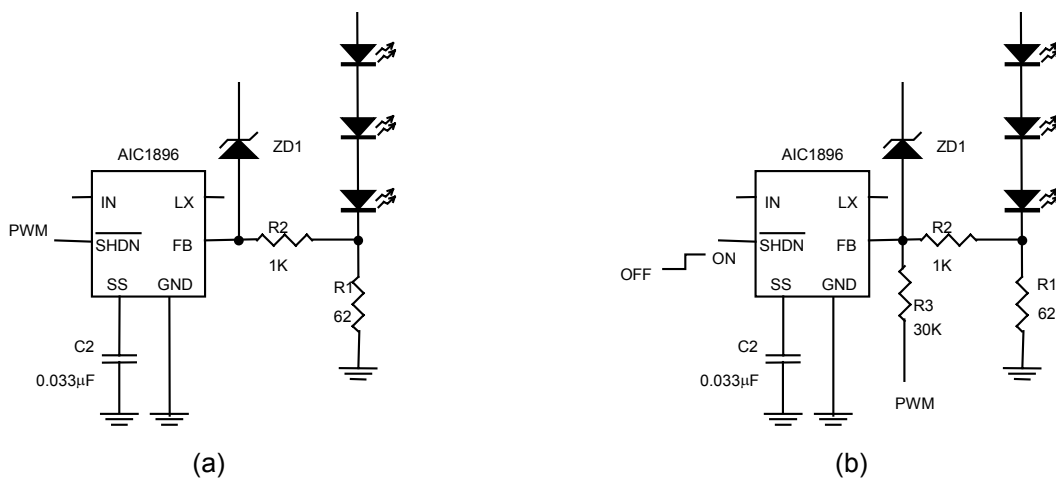

Fig. 21 Dimming Control Using a PWM Signal

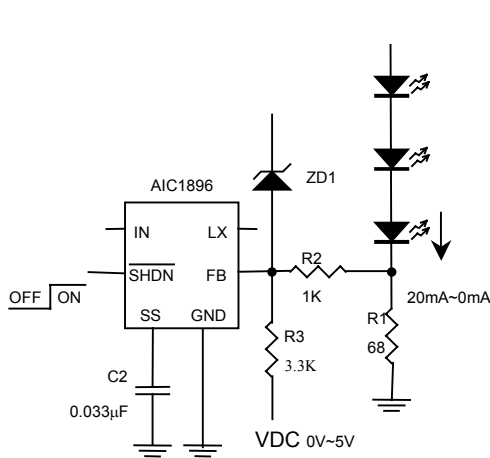

Fig. 22 Dimming Control Using a DC Voltage

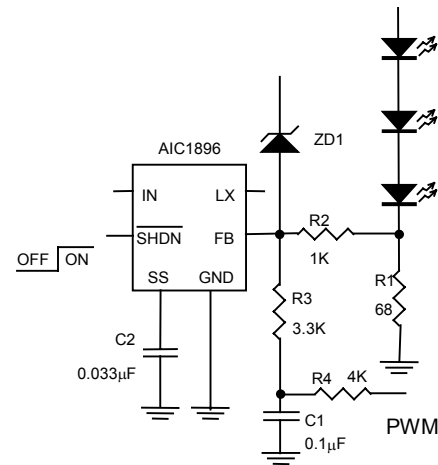

Fig. 23 Dimming Control Using a Filtered PWM Signal

APPLICATION EXAMPLES

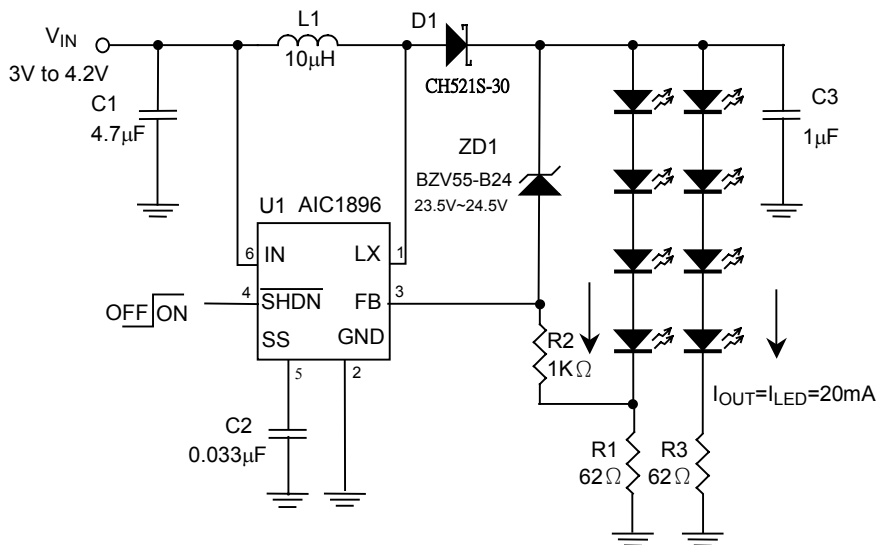
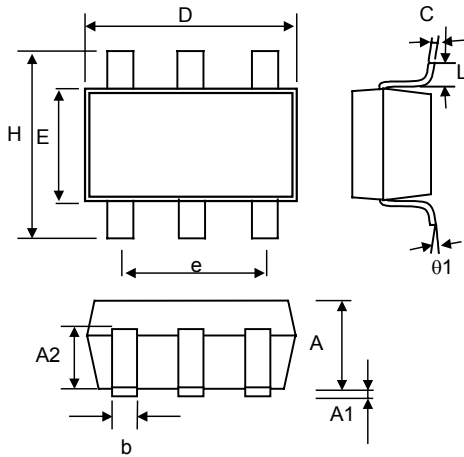

Fig. 24 Li-Ion Powered Driver for eight White LEDs with Open-Circuit Protection

■ PHYSICAL DIMENSIONS
● SOT-23-6 (unit: mm)

SYMBOL	MIN	MAX
A	1.00	1.30
A1	—	0.10
A2	0.70	0.90
b	0.35	0.50
C	0.10	0.25
D	2.70	3.10
E	1.60	2.00
e	1.90 (TYP)	
H	2.60	3.00
L	0.37	—
θ1	1°	9°