

# HIGH POWER GaAs FET

## FEATURES INCLUDE:

- 27.5 dBm Output Power with 7db Associated Gain at 8 GHz
- Power Optimized Design Provides High Power-added Efficiency
- Large Cross Section Ti/Pt/Au Gates Enhance Durability and Reliability
- Chip Devices are Selected from Standard Military Grade Wafers
- Hermetic Metal/Ceramic Package Suitable for Hi-Rel Applications
- Custom Electrical Test and Screening Available for Source Control Drawings

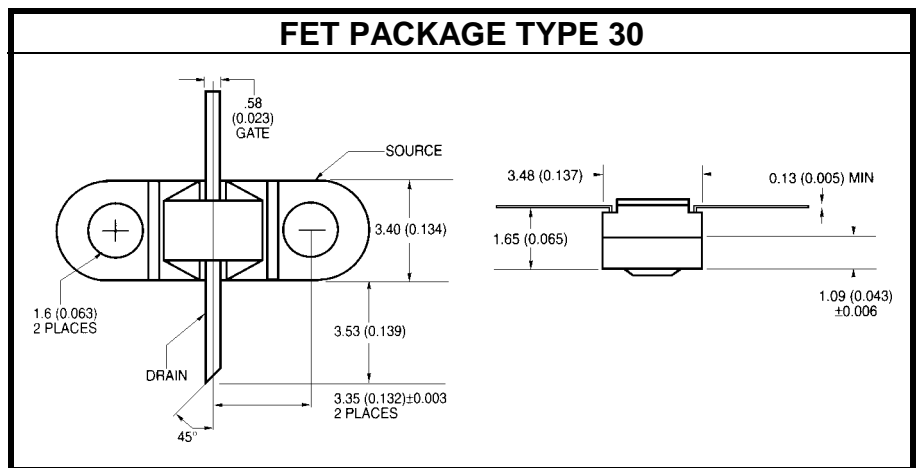

## RF ELECTRICAL SPECIFICATIONS $T_A = 25^\circ\text{C}$

SYMBOL	TEST CONDITIONS	MINIMUM	TYPICAL	MAXIMUM	UNITS
<b>MAG</b>	MAX AVAILABLE GAIN FREQUENCY = 8.0 GHz		8.5		<b>dB</b>
<b>PMAG</b>	OUTPUT POWER AT MAG TUNING FREQUENCY = 8.0 GHz		24		<b>dBm</b>