

DATA SHEET

HAL810

Programmable Linear Hall Effect Sensor

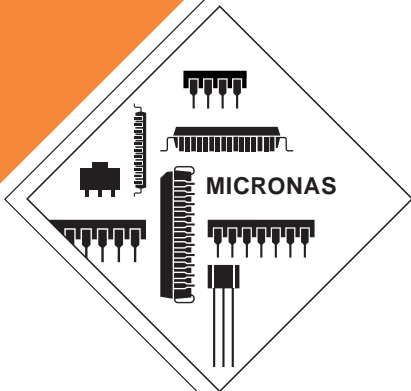

Edition June 24, 2004
6251-536-3DS

 MICRONAS

Contents

Page	Section	Title
3	1.	Introduction
3	1.1.	Major Applications
3	1.2.	Features
4	1.3.	Marking Code
4	1.3.1.	Special Marking of Prototype Parts
4	1.4.	Operating Junction Temperature Range (T_J)
4	1.5.	Hall Sensor Package Codes
4	1.6.	Solderability
4	1.7.	Pin Connections and Short Descriptions
5	2.	Functional Description
5	2.1.	General Function
7	2.2.	Digital Signal Processing and EEPROM
9	2.3.	Calibration Procedure
9	2.3.1.	General Procedure
10	2.3.2.	Calibration of the Angle Sensor
12	3.	Specifications
12	3.1.	Outline Dimensions
16	3.2.	Dimensions of Sensitive Area
16	3.3.	Position of Sensitive Areas
16	3.4.	Absolute Maximum Ratings
17	3.4.1.	Storage and Shelf Life
17	3.5.	Recommended Operating Conditions
18	3.6.	Characteristics
19	3.7.	Magnetic Characteristics
19	3.8.	Open-Circuit Detection
19	3.9.	Typical Characteristics
21	4.	Application Notes
21	4.1.	Application Circuit
21	4.2.	Measurement of a PWM Output Signal
22	4.3.	Temperature Compensation
23	4.4.	Undervoltage Behavior
23	4.5.	Ambient Temperature
23	4.6.	EMC and ESD
24	5.	Programming of the Sensor
24	5.1.	Definition of Programming Pulses
24	5.2.	Definition of the Telegram
26	5.3.	Telegram Codes
27	5.4.	Number Formats
28	5.5.	Register Information
28	5.6.	Programming Information
30	6.	Data Sheet History

Programmable Linear Hall Effect Sensor

Release Note: Revision bars indicate significant changes to the previous edition.

1. Introduction

The HAL810 is a member of the Micronas family of programmable linear Hall sensors. The linear output is provided as the duty cycle of a pulse-width modulated output signal (PWM signal).

The HAL810 is a universal magnetic field sensor with a linear output based on the Hall effect. The IC is designed and produced in sub-micron CMOS technology and can be used for angle or distance measurements if combined with a rotating or moving magnet. The major characteristics, such as magnetic field range, sensitivity, output quiescent signal (output duty cycle at $B = 0$ mT), and output duty cycle range are programmable in a non-volatile memory.

The HAL810 features a temperature-compensated Hall plate with chopped offset compensation, an A/D converter, digital signal processing, an EEPROM memory with redundancy and lock function for the calibration data, a serial interface for programming the EEPROM, and protection devices at all pins. The internal digital signal processing is of great benefit as analog offsets, temperature shifts, and mechanical stress do not lower the sensor accuracy.

The HAL810 is programmable by modulating the supply voltage. No additional programming pin is needed. The easy programmability allows a 2-point calibration by adjusting the output signal directly to the input signal (like mechanical angle, distance, or current). Individual adjustment of each sensor during the customer's manufacturing process is possible. With this calibration procedure, the tolerances of the sensor, the magnet, and the mechanical positioning can be compensated in the final assembly. This offers a low-cost alternative for all applications that presently need mechanical adjustment or laser trimming for calibrating the system.

In addition, the temperature compensation of the Hall IC can be suited to all common magnetic materials by programming first and second order temperature coefficients of the Hall sensor sensitivity. This enables operation over the full temperature range with high accuracy.

The calculation of the individual sensor characteristics and the programming of the EEPROM memory can easily be done with a PC and the application kit from Micronas.

The sensor is designed for hostile industrial and automotive applications and operates with a supply voltage of typically 5 V in the ambient temperature range

from -40 °C up to 150 °C. The HAL810 is available in the very small leaded packages TO92UT-1 and TO92UT-2.

1.1. Major Applications

Due to the sensor's versatile programming characteristics, the HAL810 is the optimal system solution for applications such as:

- contactless potentiometers,
- rotary sensors,
- distance measurements,
- magnetic field and current measurement.

WARNING:

DO NOT USE THESE SENSORS IN LIFE-SUPPORTING SYSTEMS, AVIATION, AND AEROSPACE APPLICATIONS.

1.2. Features

- high-precision linear Hall effect sensor with digital signal processing
- PWM output signal with a refresh rate of typically 125 Hz and up to 11 Bit resolution
- multiple programmable magnetic characteristics in a non-volatile memory (EEPROM) with redundancy and lock function
- open-circuit feature (ground and supply line break detection)
- temperature characteristics programmable for matching all common magnetic materials
- programmable clamping function
- programming via modulation of the supply voltage
- operation from -40 °C up to 150 °C ambient temperature
- operation with 4.5 V to 5.5 V supply voltage in specification and functions with up to 8.5 V
- operation with static magnetic fields and dynamic magnetic fields
- overvoltage and reverse-voltage protection at all pins
- magnetic characteristics extremely robust against mechanical stress
- short-circuit protected push-pull output
- EMC and ESD optimized design

1.3. Marking Code

The HAL810 has a marking on the package surface (branded side). This marking includes the name of the sensor and the temperature range.

Type	Temperature Range	
	A	K
HAL810	810A	810K

1.3.1. Special Marking of Prototype Parts

Prototype parts are coded with an underscore beneath the temperature range letter on each IC. They may be used for lab experiments and design-ins but are not intended for the use in qualification tests or as production parts.

1.4. Operating Junction Temperature Range (T_J)

The Hall sensors from Micronas are specified to the chip temperature (junction temperature T_J).

A: T_J = -40 °C to +170 °C

K: T_J = -40 °C to +140 °C

The relationship between ambient temperature (T_A) and junction temperature is explained in Section 4.5. on page 23.

1.5. Hall Sensor Package Codes

HALXXXPA-T

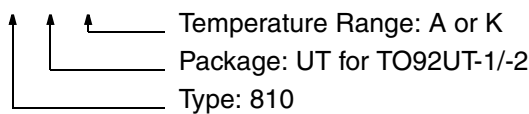

Example: **HAL810UT-K**

- Type: 810
- Package: TO92UT
- Temperature Range: T_J = -40 °C to +140 °C

Hall sensors are available in a wide variety of packaging versions and quantities. For more detailed information, please refer to the brochure: "Hall Sensors: Ordering Codes, Packaging, Handling".

1.6. Solderability

Package TO92UT-1/-2: according to IEC68-2-58

During soldering reflow processing and manual reworking, a component body temperature of 260 °C should not be exceeded.

Solderability is guaranteed for one year from the date code on the package. Solderability has been tested after storing the devices for 16 hours at 155 °C. The wettability was more than 95%.

1.7. Pin Connections and Short Descriptions

Pin No.	Pin Name	Type	Short Description
1	VDD	IN	Supply Voltage and Programming Pin
2	GND		Ground
3	OUT	OUT	Push-Pull Output

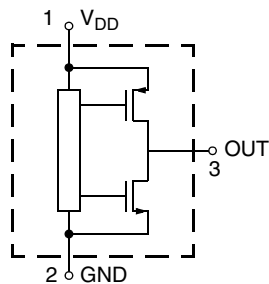

Fig. 1-1: Pin configuration

2. Functional Description

2.1. General Function

The HAL810 is a monolithic integrated circuit which provides a pulse-width modulated output signal (PWM). The duty cycle of the PWM signal is proportional to the magnetic flux through the Hall plate.

The external magnetic field component perpendicular to the branded side of the package generates a Hall voltage. The Hall IC is sensitive to magnetic north and south polarity. This voltage is converted to a digital value, processed in the Digital Signal Processing Unit (DSP) according to the settings of the EEPROM registers, converted to a pulse-width modulated output signal, and stabilized by a push-pull output transistor stage. The function and the parameters for the DSP are explained in Section 2.2. on page 7.

The setting of the LOCK register disables the programming of the EEPROM memory for all time. This register cannot be reset.

As long as the LOCK register is not set, the output characteristics can be adjusted by programming the EEPROM registers. The IC is addressed by modulating the supply voltage (see Fig. 2-1). In the supply voltage range from 4.5 V to 5.5 V, the sensor gener-

ates a PWM output signal. After detecting a command, the sensor reads or writes the memory and answers with a digital signal on the output pin. The PWM output is switched off during the communication.

The open-circuit detection provides a defined output voltage if the V_{DD} or GND line is broken. Internal temperature compensation circuitry and the chopped off-set compensation enables operation over the full temperature range with minimal changes in accuracy and high offset stability. The circuitry also rejects offset shifts due to mechanical stress from the package. The non-volatile memory consists of redundant EEPROM cells. In addition, the sensor IC is equipped with devices for overvoltage and reverse-voltage protection at all pins.

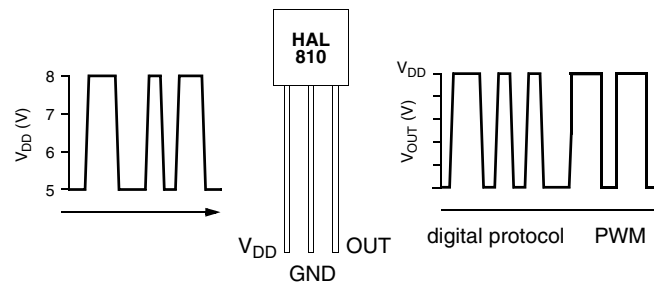

Fig. 2-1: Programming with V_{DD} modulation

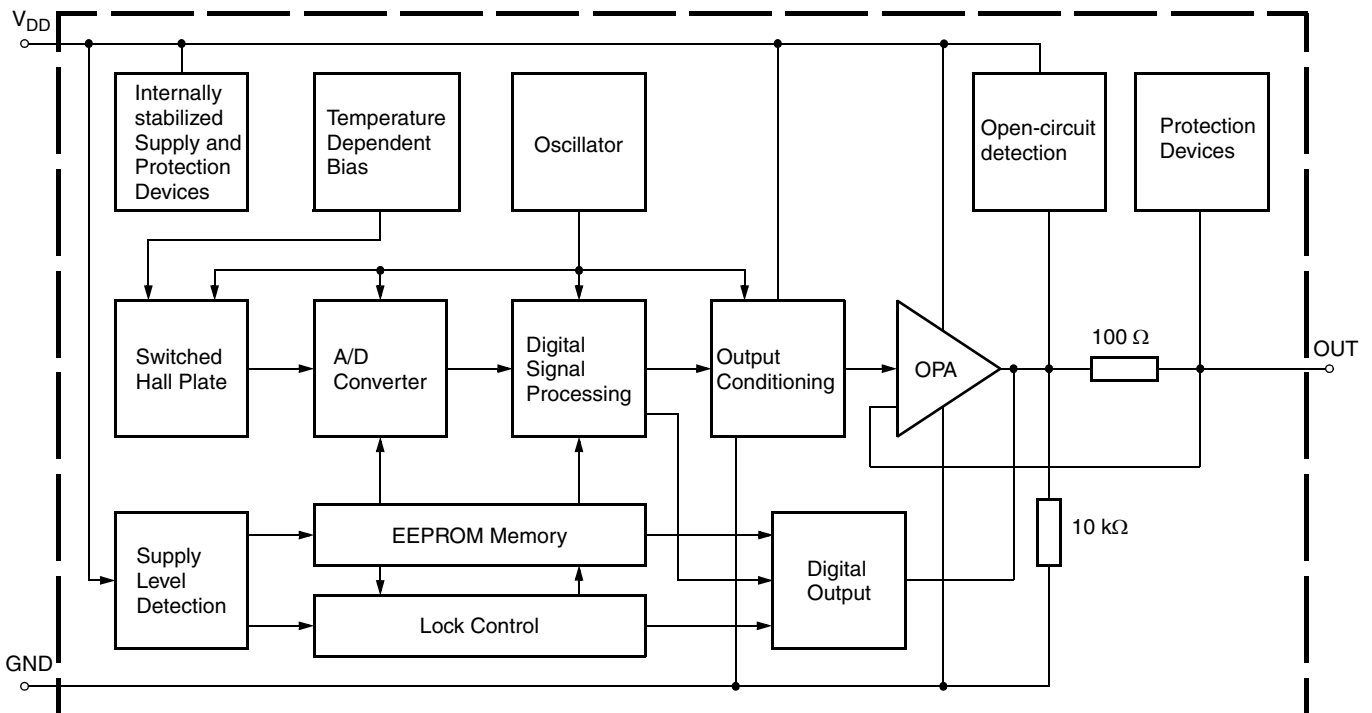

Fig. 2-2: HAL810 block diagram

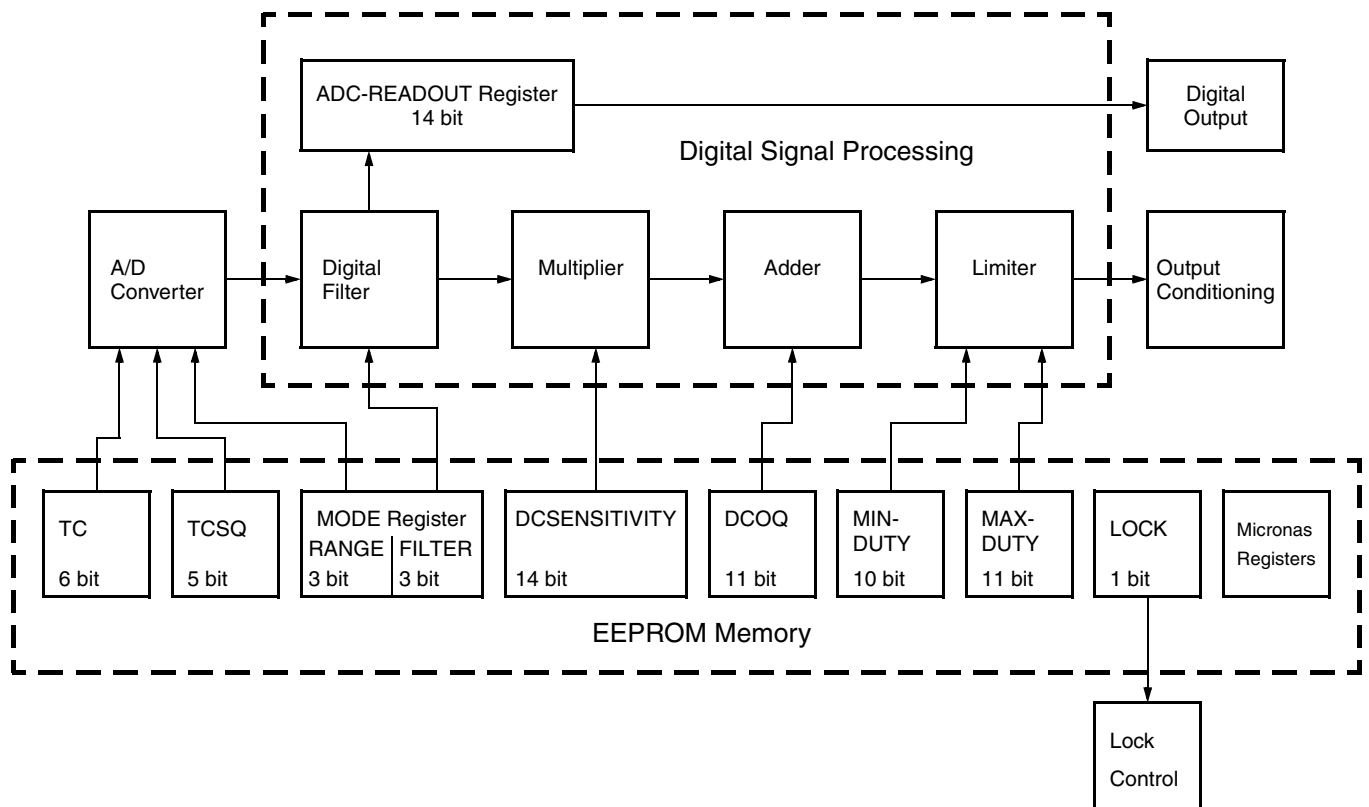

Fig. 2-3: Details of EEPROM and Digital Signal Processing

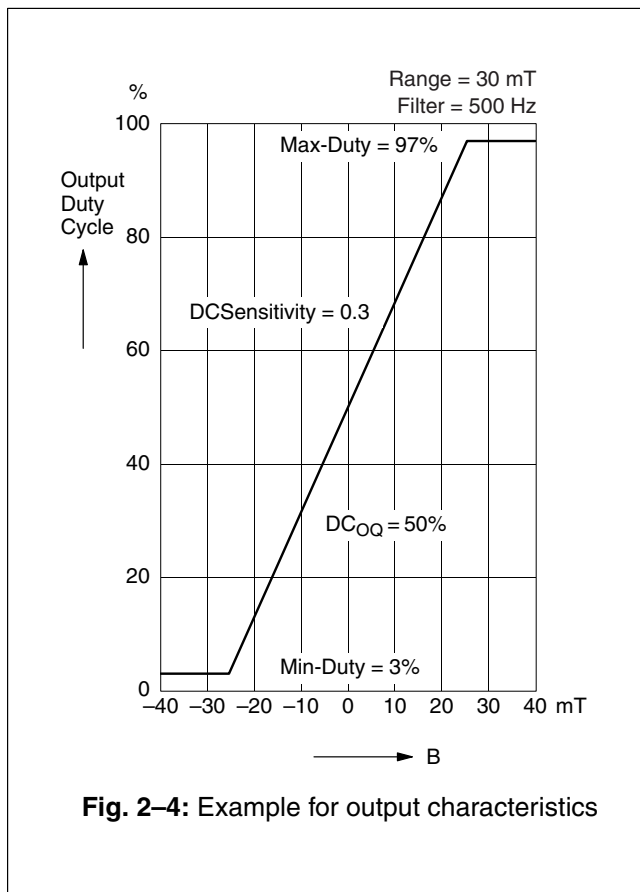

Fig. 2-4: Example for output characteristics

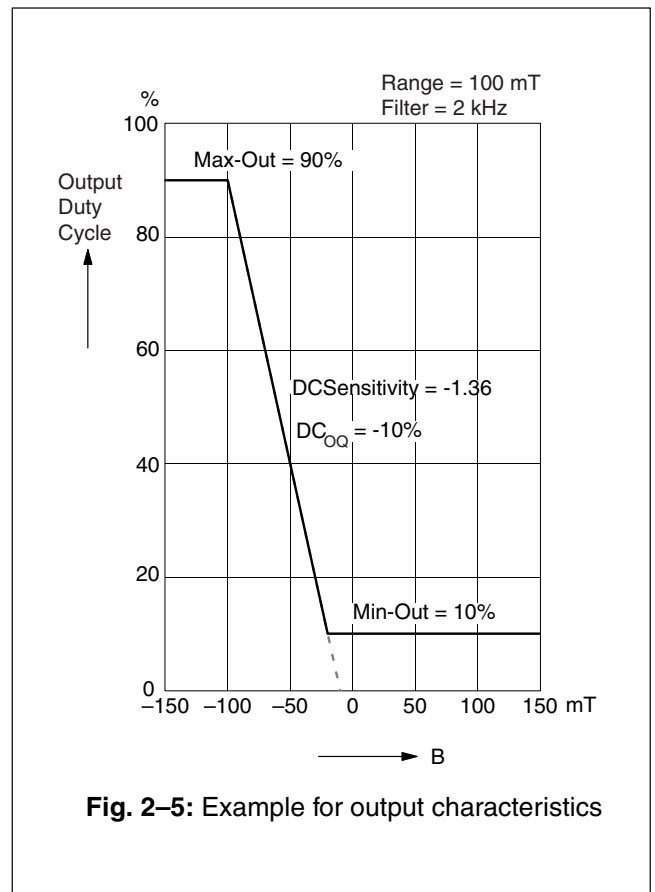

Fig. 2-5: Example for output characteristics

2.2. Digital Signal Processing and EEPROM

The DSP is the main part of this sensor and performs the signal conditioning. The parameters for the DSP are stored in the EEPROM registers. The details are shown in Fig. 2–3.

Terminology:

MIN-DUTY: name of the register or register value

Min-Duty: name of the parameter

The EEPROM registers consist of three groups:

Group 1 contains the registers for the adaptation of the sensor to the magnetic circuit: Mode for selecting the magnetic field range and filter frequency, TC and TCSQ for the temperature characteristics of the magnetic sensitivity.

Group 2 contains the registers for defining the output characteristics: DCSensitivity, DCOQ, MIN-DUTY, and MAX-DUTY. The output characteristic of the sensor is defined by these 4 parameters (see Fig. 2–5 and Fig. 2–6 for examples).

- The parameter DC_{OQ} (Output Quiescent Duty Cycle) corresponds to the duty cycle at $B = 0$ mT.
- The parameter DCSensitivity defines the magnetic sensitivity:

$$DCSensitivity = \frac{\Delta DC_{OUT} * 2048}{\Delta ADC-Readout * 100\%}$$

- The output duty cycle can be calculated as:

$$DC_{OUT} = DCSensitivity * ADC-Readout / 2048 * 100\% + DC_{OQ}$$

The output duty cycle range can be clamped by setting the registers MIN-DUTY and MAX-DUTY in order to enable failure detection (such as short-circuits to V_{DD} or GND and open connections).

Group 3 contains the Micronas registers and LOCK for the locking of all registers. The Micronas registers are programmed and locked during production and are read-only for the customer. These registers are used for oscillator frequency trimming, A/D converter offset compensation, and several other special settings.

An external magnetic field generates a Hall voltage on the Hall plate. The ADC converts the amplified positive or negative Hall voltage (operates with magnetic north and south poles at the branded side of the package) to a digital value. Positive values correspond to a magnetic north pole on the branded side of the package. The digital signal is filtered in the internal low-pass filter and is readable in the ADC-READOUT register. Depending on the programmable magnetic range of the Hall IC, the operating range of the A/D converter is from –30 mT...+30 mT up to –150 mT...+150 mT.

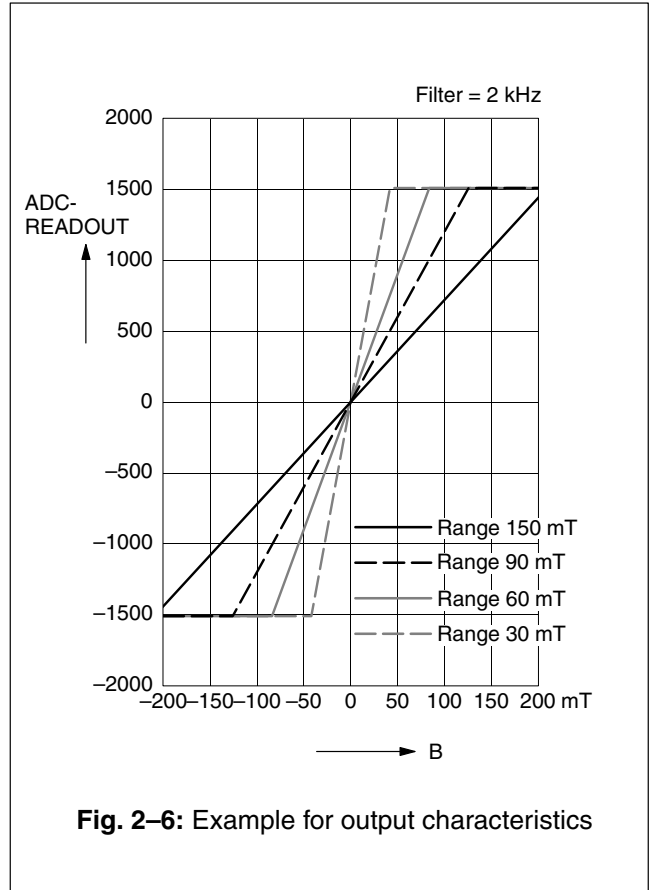

Fig. 2–6: Example for output characteristics

During further processing, the digital signal is multiplied with the sensitivity factor, added to the quiescent output duty cycle and limited according to Min-Duty and Max-Duty. The result is converted to the duty cycle of a pulse width modulated signal and stabilized by a push-pull output transistor stage.

The ADC-Readout at any given magnetic field depends on the programmed magnetic field range but also on the filter frequency. Fig. 2–6 shows the typical ADC-Readout values for the different magnetic field ranges with the filter frequency set to 2 kHz. The relationship between the minimum and maximum ADC-Readout values and the filter frequency setting is listed in the following table.

Filter Frequency	ADC-Readout range
80 Hz	–3968...3967
160 Hz	–1985...1985
500 Hz	–5292...5290
1 kHz	–2646...2645
2 kHz	–1512...1511

Note: During application design, it should be taken into consideration that the maximum and minimum ADC-READOUT is not exceeded during calibration and operation of the Hall IC. Consequently, the maximum and minimum magnetic fields that may occur in the operational range of a specific application should not saturate the A/D converter. Please note that the A/D converter saturates at magnetic fields well above, respectively below, the magnetic range limits. This large safety band between specified magnetic range and true operational range helps to avoid saturation.

Range

The RANGE bits are the three lowest bits of the MODE register; they define the magnetic field range of the A/D converter.

Magnetic Field Range	Range
-30 mT...30 mT	0
-40 mT...40 mT	4
-60 mT...60 mT	5
-75 mT...75 mT	1
-80 mT...80 mT	6
-90 mT...90 mT	2
-100 mT...100 mT	7
-150 mT...150 mT	3

Filter

The FILTER bits are the three highest bits of the MODE register; they define the -3 dB frequency of the digital low pass filter.

-3 dB Frequency	Filter
80 Hz	0
160 Hz	1
500 Hz	2
1 kHz	3
2 kHz	4

TC and TCSQ

The temperature dependence of the magnetic sensitivity can be adapted to different magnetic materials in order to compensate for the change of the magnetic strength with temperature. The adaptation is done by programming the TC (Temperature Coefficient) and the TCSQ registers (Quadratic Temperature Coefficient). Thereby, the slope and the curvature of the temperature dependence of the magnetic sensitivity can be matched to the magnet and the sensor assembly. As a result, the output characteristic can be fixed over the full temperature range. The sensor can compensate for linear temperature coefficients ranging from about -3100 ppm/K up to 400 ppm/K and quadratic coefficients from about -5 ppm/K² to 5 ppm/K². Please refer to Section 4.3. on page 22 for the recommended settings for different linear temperature coefficients.

DCSensitivity

The DCSENSITIVITY register contains the parameter for the multiplier in the DSP. The DCSensitivity is programmable between -4 and 4. The register can be changed in steps of 0.00049. DCSensitivity = 1 corresponds to an increase of the output duty cycle by 100% if ADC-Readout increases by 2048.

For all calculations, the digital value of the A/D converter is used. This digital information is derived from the magnetic signal and is readable from the ADC-READOUT register.

$$DCSensitivity = \frac{\Delta DC_{OUT} * 2048}{\Delta ADC-Readout * 100\%}$$

DC_{0Q}

The DCOQ register contains the parameter for the adder in the DSP. DC_{0Q} is the output duty cycle without external magnetic field (B = 0 mT, respectively ADC-Readout = 0) and programmable from -100% to 100%. The register can be changed in steps of 0.0976%.

Note: If DC_{0Q} is programmed as negative values, the maximum output duty cycle is limited to:

$$DC_{OUTmax} = DC_{0Q} + 100\%$$

For calibration in the system environment, a 2-point adjustment procedure (see Section 2.3.) is recommended. The suitable DCSensitivity and DC_{0Q} values for each sensor can be calculated individually by this procedure.

Clamping Function

The output duty cycle range can be clamped in order to detect failures like shorts of the output signal to V_{DD} or GND or an open circuit.

The MIN-DUTY register contains the parameter for the lower limit. The minimum duty cycle is programmable between 0% and 50% in steps of 0.0488%.

The MAX-DUTY register contains the parameter for the upper limit. The maximum duty cycle is programmable between 0% and 100% in steps of 0.0488%.

LOCKR

By setting this 1-bit register, all registers will be locked, and the sensor will no longer respond to any supply voltage modulation. This bit is active after the first power-off and power-on sequence after setting the LOCK bit.

Warning: This register cannot be reset!

ADC-READOUT

This 14-bit register delivers the actual digital value of the applied magnetic field before the signal processing. This register can be read out and is the basis for the calibration procedure of the sensor in the system environment.

2.3. Calibration Procedure

2.3.1. General Procedure

For calibration in the system environment, the application kit from Micronas is recommended. It contains the hardware for the generation of the serial telegram for programming and the corresponding software for the input of the register values.

In this section, programming of the sensor using this programming tool is explained. Please refer to Section 5. on page 24 for information about programming without this tool.

For the individual calibration of each sensor in the customer application, a two point adjustment is recommended (see Fig. 2–7 for an example). When using the application kit, the calibration can be done in three steps:

Step 1: Input of the registers which need not be adjusted individually

The magnetic circuit, the magnetic material with its temperature characteristics, the filter frequency, and low and high clamping duty cycles are given for this application.

Therefore, the values of the following registers should be identical for all sensors of the customer application.

- Filter
(according to the maximum signal frequency)
- Range
(according to the maximum magnetic field at the sensor position)
- TC and TCSQ
(depends on the material of the magnet and the other temperature dependencies of the application)
- Min-Duty and Max-Duty
(according to the application requirements)

Write and store the appropriate settings into the HAL810 registers.

Step 2: Calculation of DC_{OQ} and DCSensitivity

The calibration points 1 and 2 can be set inside the specified range. The corresponding values for DC₁ and DC₂ result from the application requirements.

$$Min-Duty \leq DC_{1,2} \leq Max-Duty$$

For highest accuracy of the sensor, calibration points near the minimum and maximum input signal are recommended. The difference of the duty cycle between calibration point 1 and calibration point 2 should be more than 70%.

Set the system to calibration point 1 and read the register ADC-READOUT. The result is ADC-Readout1.

Now, set the system to calibration point 2, read the register ADC-READOUT, and get ADC-Readout2.

With these readouts and the nominal duty cycles DC₁ and DC₂, for the calibration points 1 and 2, respectively, the values for DCSensitivity and DC_{OQ} are calculated as:

$$DCSensitivity = \frac{DC_2 - DC_1}{ADC-Readout2 - ADC-Readout1} * \frac{2048}{100\%}$$

$$DC_{OQ} = DC_1 - \frac{ADC-Readout1 * DCSensitivity * 100\%}{2048}$$

This calculation has to be done individually for each sensor.

Next, write and store the calculated values for DCSensitivity and DC_{OQ} into the IC for adjusting the sensor.

The sensor is now calibrated for the customer application. However, the programming can be changed again and again if necessary.

Step 3: Locking the Sensor

The last step is activating the lock function with the "LOCK" command. Please note that the LOCK function becomes effective after power-down and power-up of the Hall IC. The sensor is now locked and does not respond to any programming or reading commands.

Warning: This register cannot be reset!

2.3.2. Calibration of the Angle Sensor

The following description explains the calibration procedure using an angle sensor as an example. The required output characteristic is shown in Fig. 2-7.

- the angle range is from -25° to 25°
- temperature coefficient of the magnet: -500 ppm/K

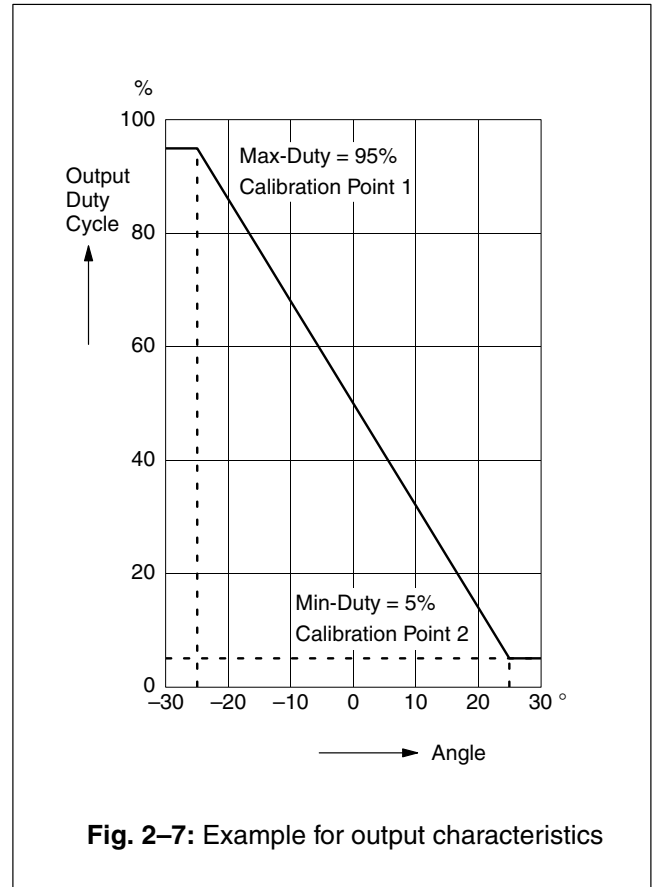

Fig. 2-7: Example for output characteristics

Step 1: Input of the registers which need not be adjusted individually

The register values for the following registers are given for all applications:

- Filter
Select the filter frequency: 500 Hz
- Range
Select the magnetic field range: 30 mT
- TC
For this magnetic material: 6
- TCSQ
For this magnetic material: 14
- Min-Duty
For our example: 5%
- Max-Duty
For our example: 95%

Enter these values in the software, and use the “write and store” command for permanently writing the values in the registers.

Step 2: Calculation of DC_{OQ} and $DCSensitivity$

There are two ways to calculate the values for DC_{OQ} and $DCSensitivity$.

Manual Calculation:

Set the system to calibration point 1 (angle 1 = -25°) and read the register ADC-Readout. For our example, the result is $ADC\text{-Readout}1 = -2500$.

Next, set the system to calibration point 2 (angle 2 = 25°), and read the register ADC-Readout again. For our example, the result is $ADC\text{-Readout}2 = +2350$.

With these measurements and the targets $DC_1 = 95\%$ and $DC_2 = 5\%$, the values for $DCSensitivity$ and DC_{OQ} are calculated as

$$DCSensitivity = \frac{5\% - 95\%}{2350 + 2500} * \frac{2048}{100\%} = -0.3800$$

$$DC_{OQ} = 95\% - \frac{-2500 * (-0.3800) * 100\%}{2048} = 48.61\%$$

Software Calibration:

Use the menu CALIBRATE from the PC software and enter the values 95% for DC_1 and 5% for DC_2 . Set the system to calibration point 1 (angle 1 = -25°), press the key “Read ADC-Readout1”, set the system to calibration point 2 (angle 2 = 25°), press the key “Read ADC-Readout2”, and hit the button “Calculate”. The software will then calculate the appropriate DC_{OQ} and $DCSensitivity$.

This calculation has to be done individually for each sensor. Now, write the calculated values with the “write and store” command into the HAL810 for programming the sensor.

Step 3: Locking the Sensor

The last step is to activate the lock function with the “lock” command. Please note that the LOCK function becomes effective after power-down and power-up of the Hall IC. The sensor is now locked and does not respond to any programming or reading commands.

Warning: This register cannot be reset!

3. Specifications

3.1. Outline Dimensions

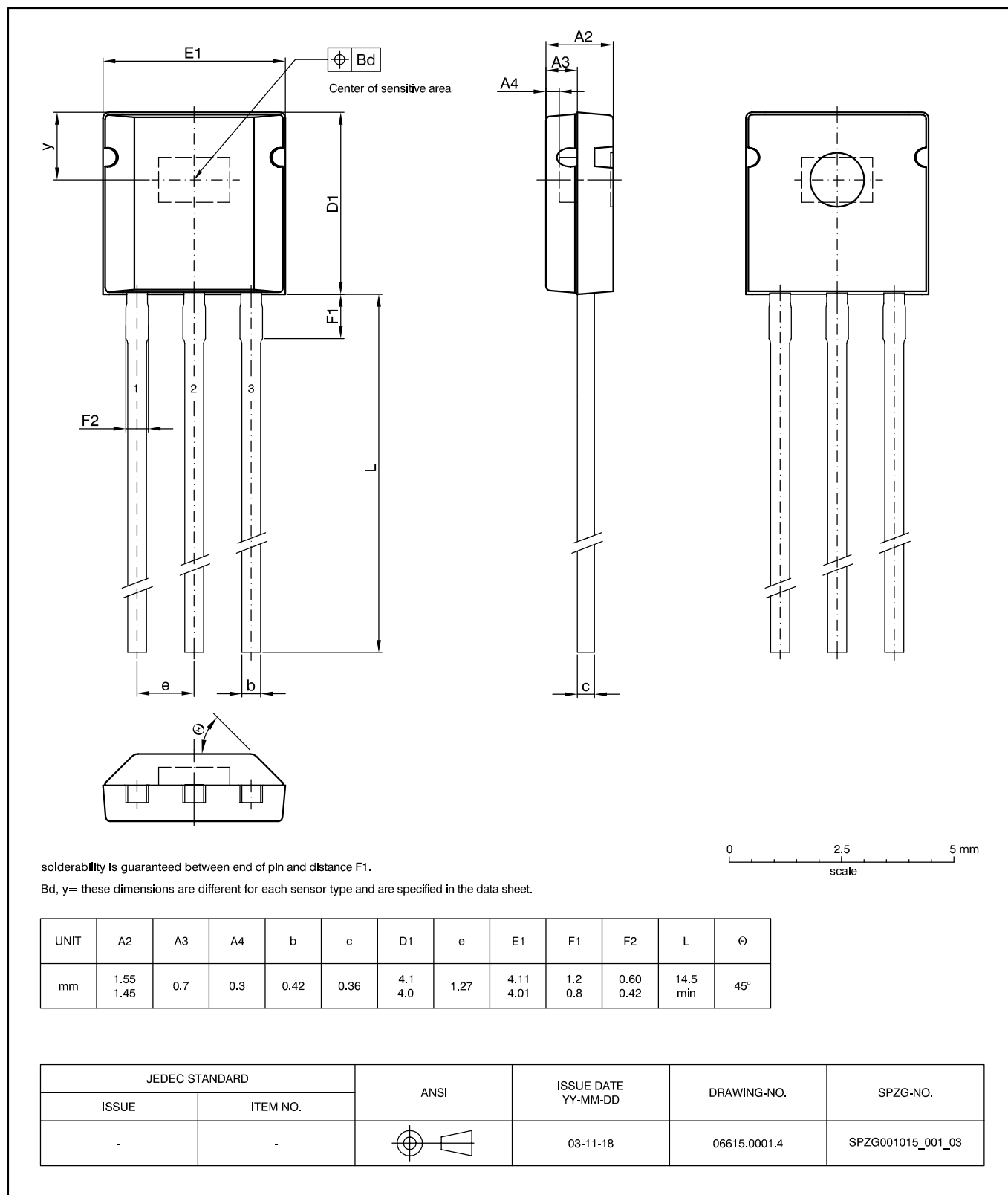

Fig. 3-1:
TO92UT-2: Plastic Transistor Standard UT package, 3 leads
Weight approximately 0.12 g

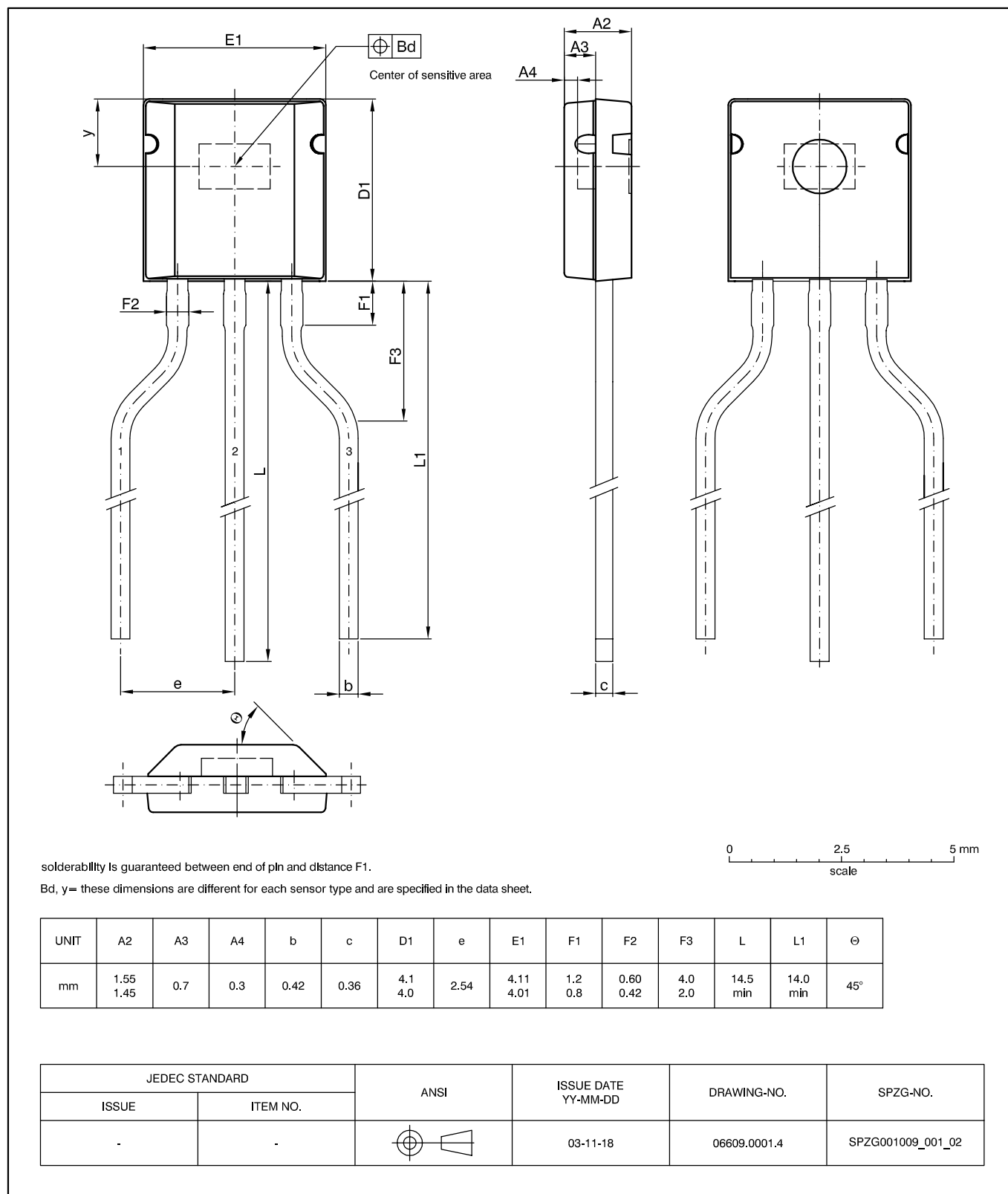

Fig. 3-2:
TO92UT-1: Plastic Transistor Standard UT package, 3 leads, spread
 Weight approximately 0.12 g

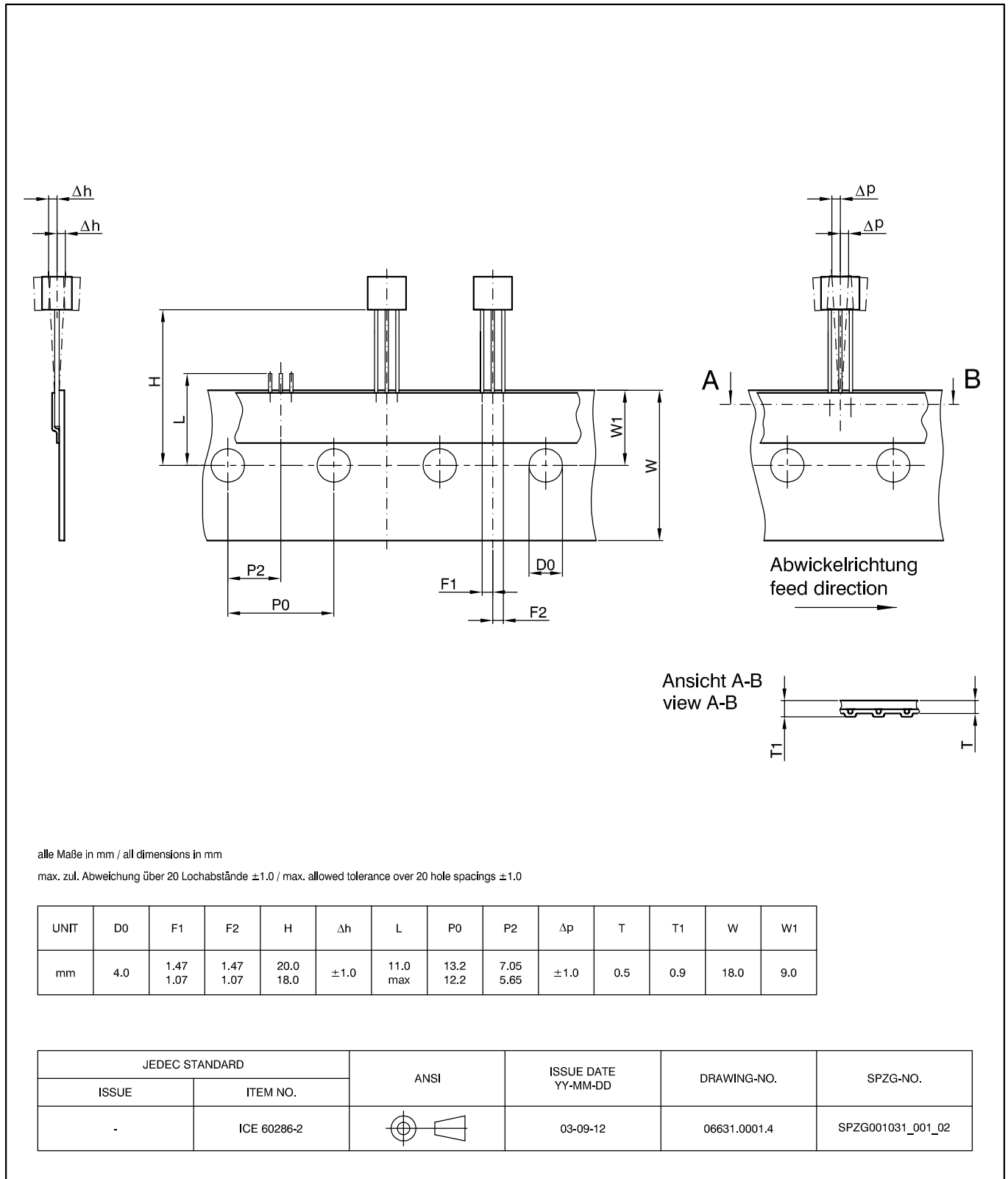

Fig. 3-3:
TO92UT-2: Dimensions ammpack inline

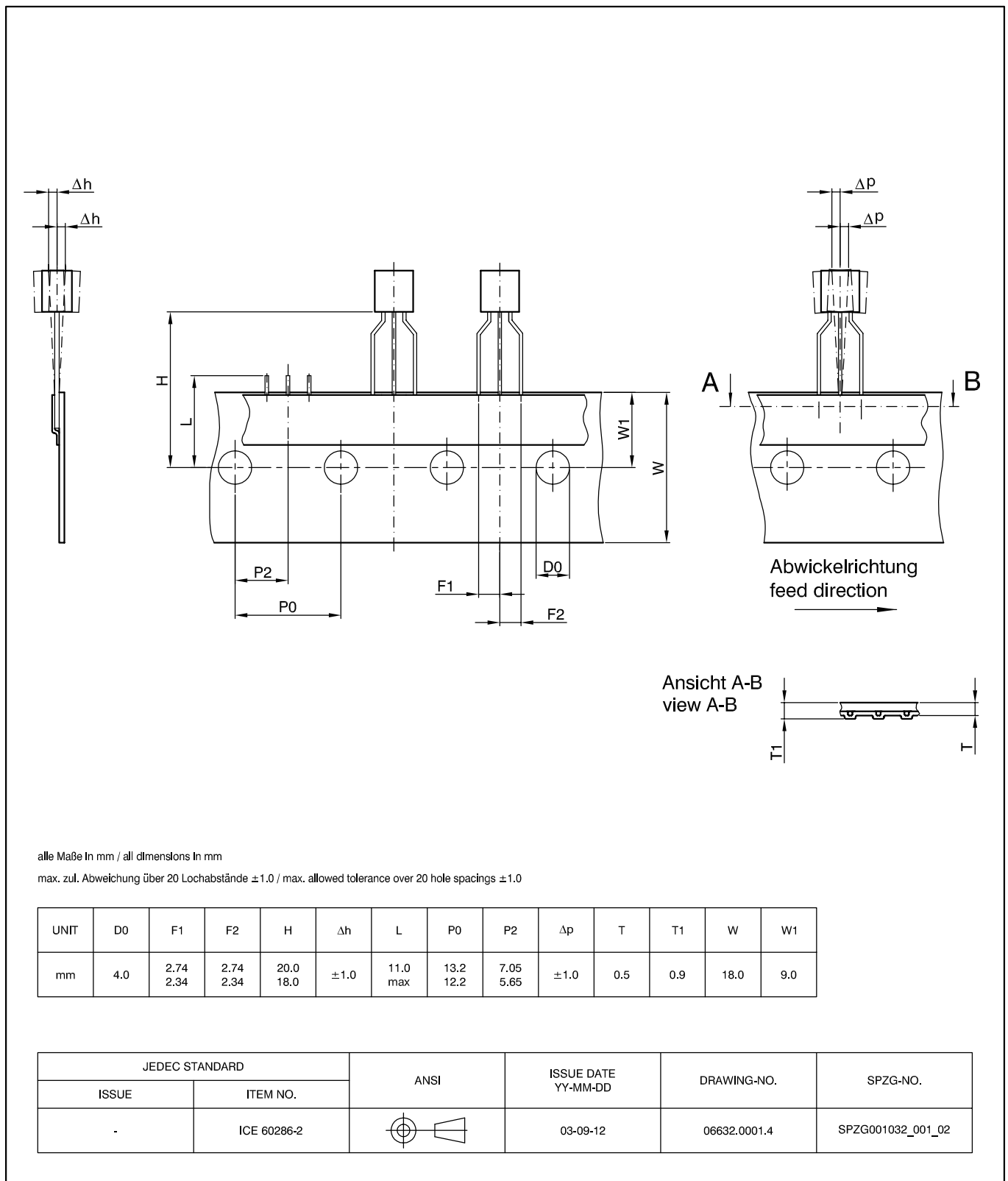

Fig. 3-4:
T092UT-1: Dimensions ammpack inline, spread

3.2. Dimensions of Sensitive Area

0.25 mm x 0.25 mm

3.3. Position of Sensitive Areas

TO92UT-1/-2	
x	center of the package
y	1.5 mm nominal
Bd	0.3 mm

3.4. Absolute Maximum Ratings

Stresses beyond those listed in the “Absolute Maximum Ratings” may cause permanent damage to the device. This is a stress rating only. Functional operation of the device at these conditions is not implied. Exposure to absolute maximum rating conditions for extended periods will affect device reliability.

This device contains circuitry to protect the inputs and outputs against damage due to high static voltages or electric fields; however, it is advised that normal precautions be taken to avoid application of any voltage higher than absolute maximum-rated voltages to this circuit.

All voltages listed are referenced to ground (GND).

Symbol	Parameter	Pin No.	Min.	Max.	Unit
V_{DD}	Supply Voltage	1	-8.5	8.5	V
V_{DD}	Supply Voltage	1	-14.4 ^{1) 2)}	14.4 ^{1) 2)}	V
$-I_{DD}$	Reverse Supply Current	1	-	50 ¹⁾	mA
V_{OUT}	Output Voltage	3	-5 ⁵⁾ -5 ⁵⁾	8.5 ³⁾ 14.4 ^{3) 2)}	V
$V_{OUT} - V_{DD}$	Excess of Output Voltage over Supply Voltage	3,1		2	V
I_{OUT}	Continuous Output Current	3	-10	10	mA
t_{Sh}	Output Short Circuit Duration	3	-	10	min
T_J	Junction Temperature Range		-40 -40	170 ⁴⁾ 150	°C °C
N_{PROG}	Number of Programming Cycles		-	100	

¹⁾ as long as T_{Jmax} is not exceeded

²⁾ $t < 10$ min ($V_{DDmin} = -15$ V for $t < 1$ min, $V_{DDmax} = 16$ V for $t < 1$ min)

³⁾ as long as T_{Jmax} is not exceeded, output is not protected to external 14 V-line (or to -14 V)

⁴⁾ $t < 1000$ h

⁵⁾ internal protection resistor = 100 Ω

3.4.1. Storage and Shelf Life

The permissible storage time (shelf life) of the sensors is unlimited, provided the sensors are stored at a maximum of 30 °C and a maximum of 85% relative humidity. At these conditions, no Dry Pack is required.

Solderability is guaranteed for one year from the date code on the package. Solderability has been tested after storing the devices for 16 hours at 155 °C. The wettability was more than 95%.

3.5. Recommended Operating Conditions

Functional operation of the device beyond those indicated in the “Recommended Operating Conditions/Characteristics” is not implied and may result in unpredictable behavior of the device and may reduce reliability and lifetime.

All voltages listed are referenced to ground (GND).

Symbol	Parameter	Pin No.	Min.	Typ.	Max.	Unit
V _{DD}	Supply Voltage	1	4.5	5	5.5	V
I _{OUT}	Continuous Output Current	3	-1	-	1	mA
R _L	Load Resistor	3	4.5	-	-	kΩ
C _L	Load Capacitance	3	0.33	10	100	nF

3.6. Characteristics

at $T_J = -40\text{ °C}$ to $+170\text{ °C}$, $V_{DD} = 4.5\text{ V}$ to 5.5 V , $GND = 0\text{ V}$ after programming, at Recommended Operation Conditions if not otherwise specified in the column “Conditions”. Typical Characteristics for $T_J = 25\text{ °C}$ and $V_{DD} = 5\text{ V}$.

Symbol	Parameter	Pin No.	Min.	Typ.	Max.	Unit	Conditions
I_{DD}	Supply Current over Temperature Range	1	–	7	10	mA	
V_{DDZ}	Overshoot Protection at Supply	1	–	17.5	20	V	$I_{DD} = 25\text{ mA}$, $T_J = 25\text{ °C}$, $t = 20\text{ ms}$
V_{OZ}	Overshoot Protection at Output	3	–	17	19.5	V	$I_O = 10\text{ mA}$, $T_J = 25\text{ °C}$, $t = 20\text{ ms}$
	Output Duty Cycle Resolution	3	–	–	11	bit	1)
INL	Non-Linearity of Output Duty Cycle over Temperature	3	–0.5	0	0.5	%	2)
ΔT_K	Variation of Linear Temperature Coefficient	3	–400	0	400	ppm/k	if TC and TCSQ suitable for the application
$\Delta DC_{MIN-DUTY}$	Accuracy of Minimum Duty Cycle over Temperature Range	3	–1	0	1	%	
$\Delta DC_{MAX-DUTY}$	Accuracy of Maximum Duty Cycle over Temperature Range	3	–1	0	1	%	
V_{OUTH}	Output High Voltage	3	–	4.8	–	V	$V_{DD} = 5\text{ V}$, $-1\text{ mA} \leq I_{OUT} \leq 1\text{ mA}$
V_{OUTL}	Output Low Voltage	3	–	0.2	–	V	$V_{DD} = 5\text{ V}$, $-1\text{ mA} \leq I_{OUT} \leq 1\text{ mA}$
f_{PWM}	PWM Output Frequency over Temperature Range	–	105	125	145	Hz	
f_{ADC}	Internal ADC Frequency over Temperature Range	–	110	128	150	kHz	
t_{POD}	Power-Up Time (Time to reach valid duty cycle)	–	–	–	25	ms	
R_{OUT}	Output Resistance over Recommended Operating Range	3	–	1	10	Ω	$V_{OUTLmax} \leq V_{OUT} \leq V_{OUTHmin}$
R_{thJA} TO92UT-1, TO92UT-2	Thermal Resistance Junction to Soldering Point	–	–	150	200	K/W	
1) if the Hall IC is programmed accordingly 2) if more than 50% of the selected magnetic field range are used							

3.7. Magnetic Characteristics

at $T_J = -40\text{ °C}$ to $+170\text{ °C}$, $V_{DD} = 4.5\text{ V}$ to 5.5 V , $GND = 0\text{ V}$ after programming, at Recommended Operation Conditions if not otherwise specified in the column “Conditions”. Typical Characteristics for $T_J = 25\text{ °C}$ and $V_{DD} = 5\text{ V}$.

Symbol	Parameter	Pin No.	Min.	Typ.	Max.	Unit	Test Conditions
B_{Offset}	Magnetic Offset	3	-0.5	0	0.5	mT	$B = 0\text{ mT}$, $T_J = 25\text{ °C}$, unadjusted sensor
$\Delta B_{\text{Offset}}/\Delta T$	Magnetic Offset Change due to T_J		-10	0	10	$\mu\text{T/K}$	$B = 0\text{ mT}$

3.8. Open-Circuit Detection

at $T_J = -40\text{ °C}$ to $+170\text{ °C}$, Typical Characteristics for $T_J = 25\text{ °C}$

Symbol	Parameter	Pin No.	Min.	Typ.	Max.	Unit	Test Conditions
V_{OUT}	Output voltage at open V_{DD} line	3	0	0	0.2	V	$V_{DD} = 5\text{ V}$ $R_L = 10\text{ k}\Omega$ to GND
V_{OUT}	Output voltage at open GND line	3	4.7	4.8	5	V	$V_{DD} = 5\text{ V}$ $R_L = 10\text{ k}\Omega$ to GND

3.9. Typical Characteristics

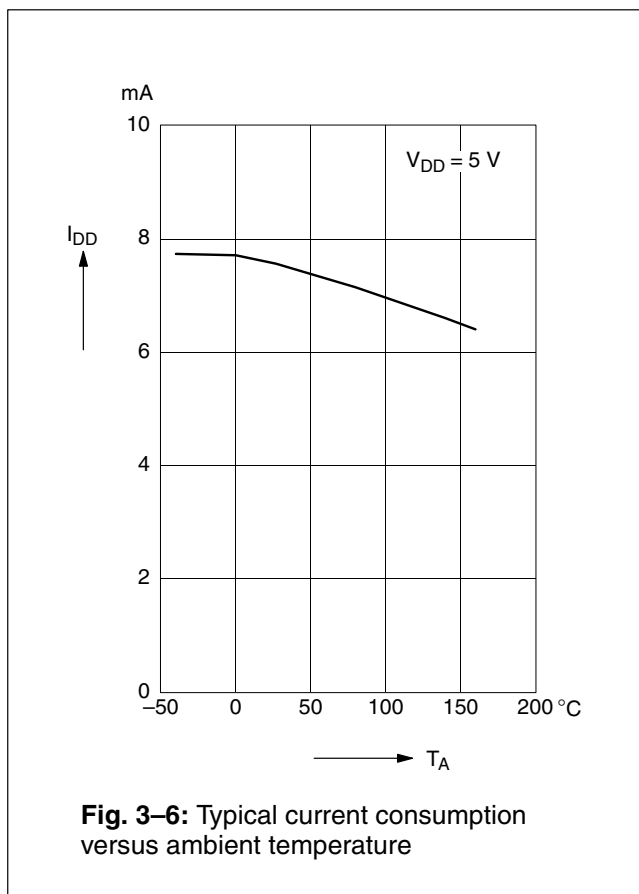
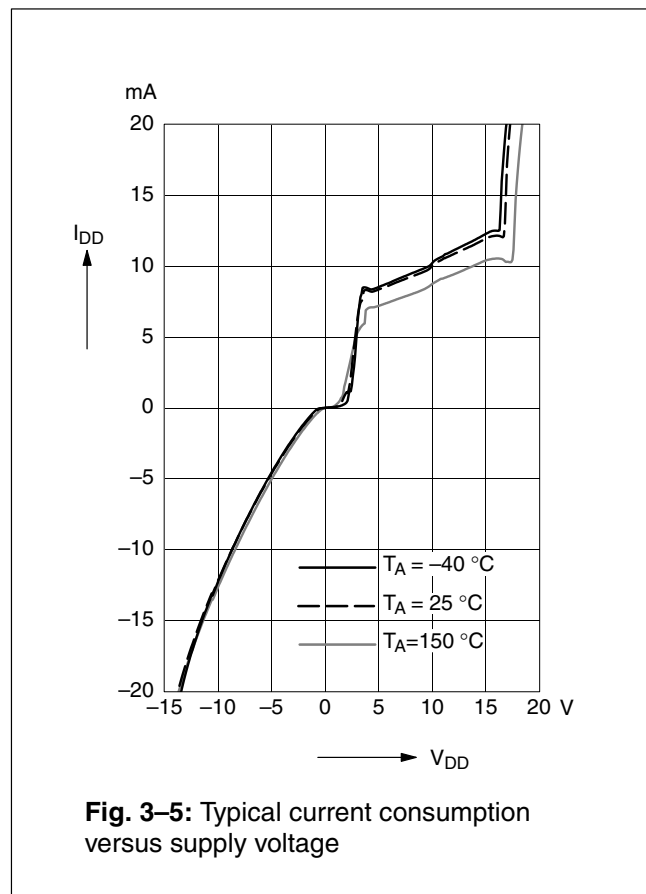

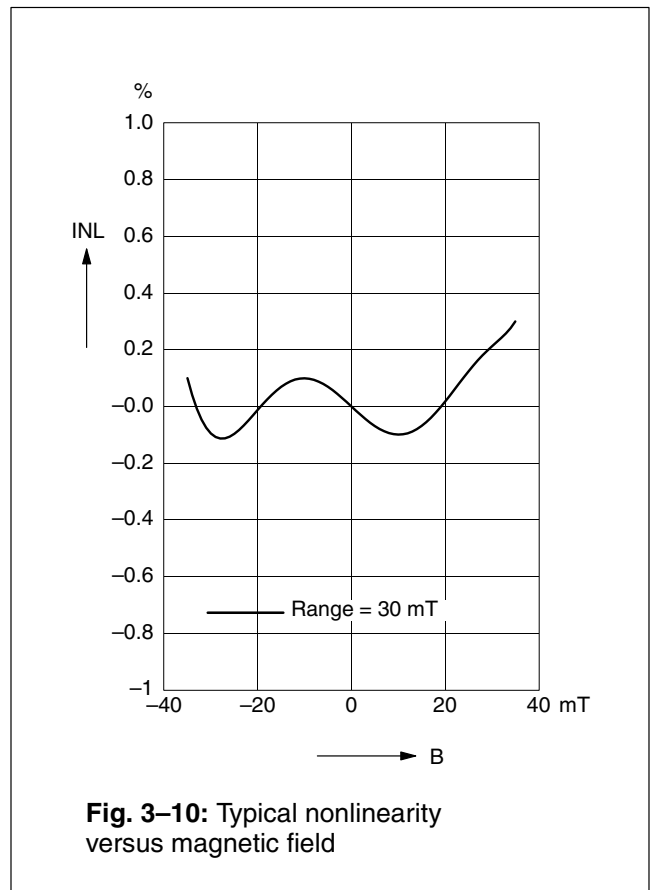
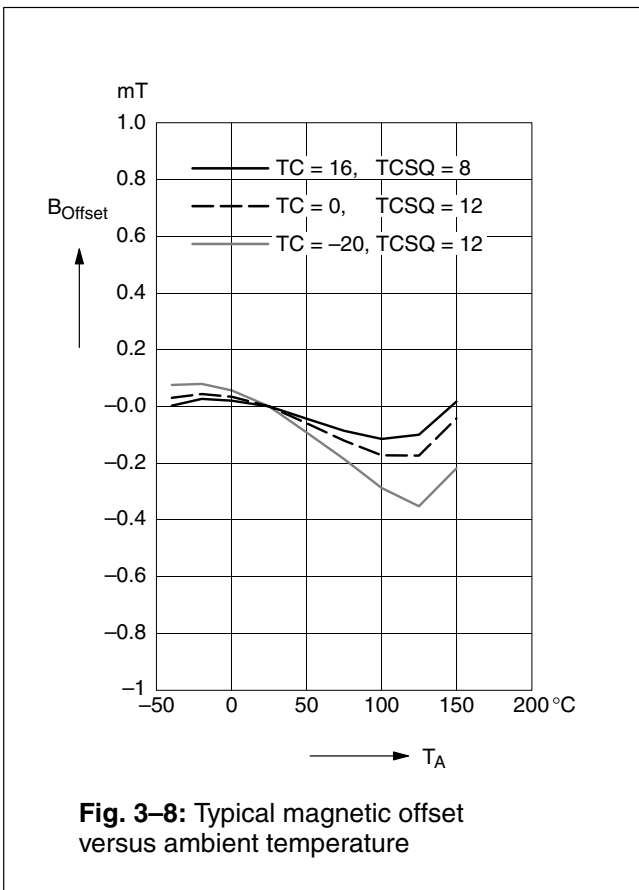
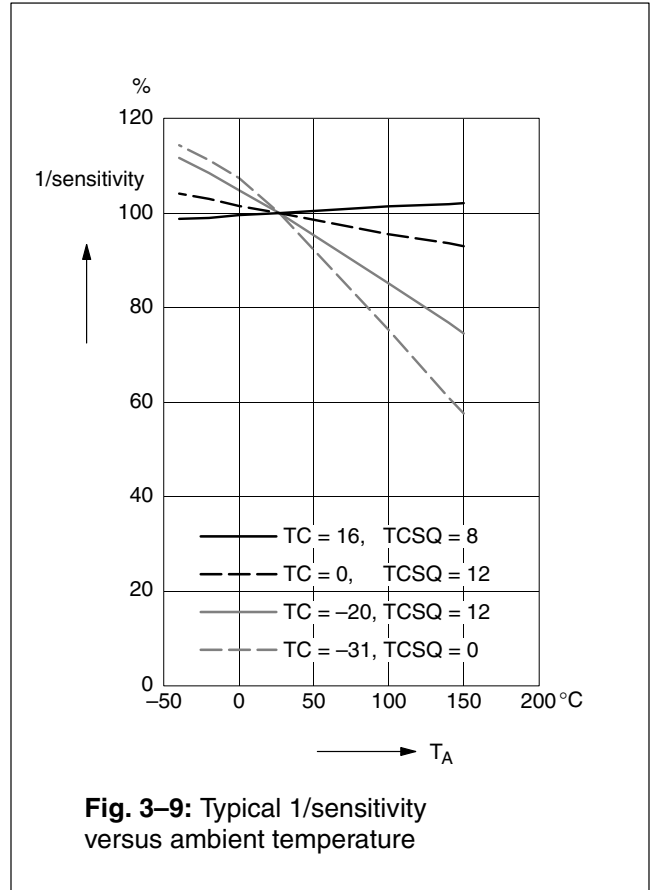
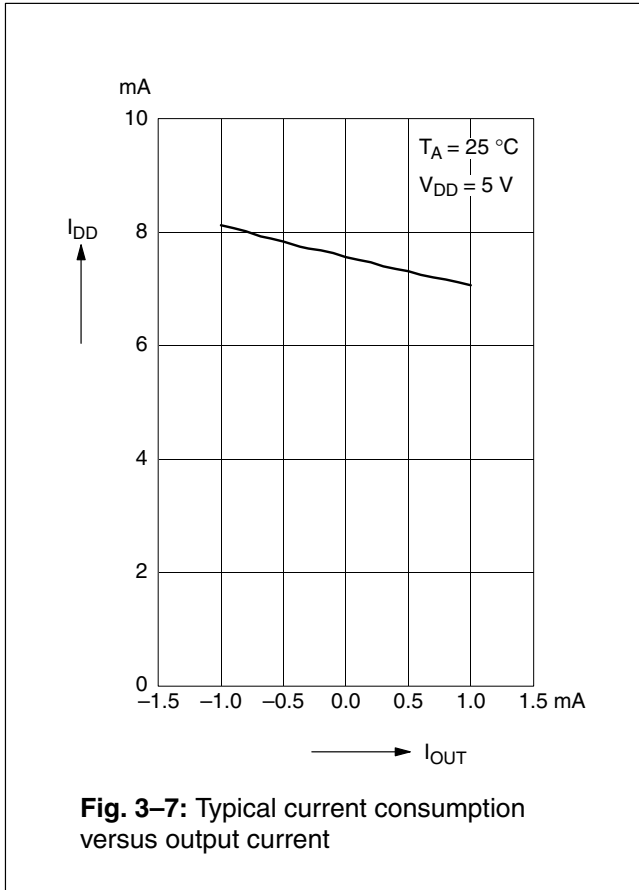

4. Application Notes

4.1. Application Circuit

For EMC protection, it is recommended to connect one ceramic 4.7 nF capacitor each between ground and the supply voltage, respectively the output pin. In addition, the input of the controller unit should be pulled-down with a 4.7 kOhm resistor and a ceramic 4.7 nF capacitor.

Please note that during programming, the sensor will be supplied repeatedly with the programming voltage of 12.5 V for 100 ms. All components connected to the V_{DD} line at this time must be able to resist this voltage.

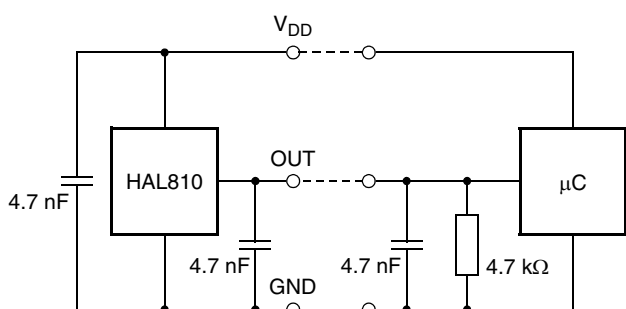

Fig. 4-1: Recommended application circuit

4.2. Measurement of a PWM Output Signal

The magnetic field information is coded in the duty-cycle of the PWM signal. The duty-cycle is defined as the ratio between the high time “s” and the period “d” of the PWM signal (see Fig. 4-2).

Please note: The PWM signal is updated with the falling edge. If the duty-cycle is evaluated with a microcontroller, the trigger-level will be the falling edge of the PWM signal.

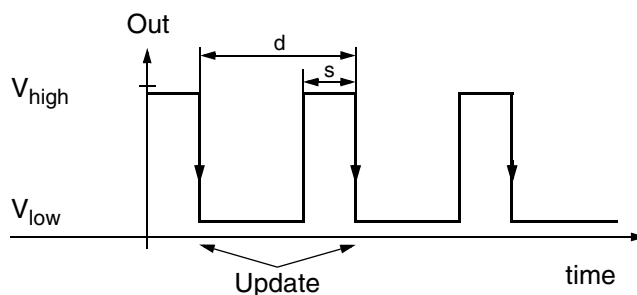

Fig. 4-2: Definition of PWM signal

4.3. Temperature Compensation

The relationship between the temperature coefficient of the magnet and the corresponding TC and TCSQ codes for linear compensation is given in the following table. In addition to the linear change of the magnetic field with temperature, the curvature can be adjusted as well. For this purpose, other TC and TCSQ combinations are required which are not shown in the table. Please contact Micronas for more detailed information on this higher order temperature compensation.

- The HAL8x5 and HAL810 contain the same temperature compensation circuits. If an optimal setting for the HAL8x5 is already available, the same settings may be used for the HAL810.

Temperature Coefficient of Magnet (ppm/K)	TC	TCSQ
400	31	6
300	28	7
200	24	8
100	21	9
0	18	10
-50	17	10
-90	16	11
-130	15	11
-170	14	11
-200	13	12
-240	12	12
-280	11	12
-320	10	13
-360	9	13
-410	8	13
-450	7	13
-500	6	14
-550	5	14
-600	4	14
-650	3	14
-700	2	15
-750	1	15

Temperature Coefficient of Magnet (ppm/K)	TC	TCSQ
-810	0	15
-860	-1	16
-910	-2	16
-960	-3	16
-1020	-4	17
-1070	-5	17
-1120	-6	17
-1180	-7	18
-1250	-8	18
-1320	-9	19
-1380	-10	19
-1430	-11	20
-1500	-12	20
-1570	-13	20
-1640	-14	21
-1710	-15	21
-1780	-16	22
-1870	-17	22
-1950	-18	23
-2030	-19	23
-2100	-20	24
-2180	-21	24
-2270	-22	25
-2420	-24	26
-2500	-25	27
-2600	-26	27
-2700	-27	28
-2800	-28	28
-2900	-29	29
-3000	-30	30
-3100	-31	31

4.4. Undervoltage Behavior

In a voltage range of below 4.5 V to approximately 3.5 V, the typical operation of the HAL810 is given and predictable for the most sensors. Some of the parameters may be out of the specification. Below about 3.5 V, the digital processing is reset. If the supply voltage rises above approx. 3.5 V once again, a startup time of about 20 μ s elapses, for the digital signal processing to occur.

4.5. Ambient Temperature

Due to the internal power dissipation, the temperature on the silicon chip (junction temperature T_J) is higher than the temperature outside the package (ambient temperature T_A).

$$T_J = T_A + \Delta T$$

At static conditions and continuous operation, the following equation applies:

$$\Delta T = I_{DD} * V_{DD} * R_{thJA}$$

For typical values, use the typical parameters. For worst case calculation, use the maximum parameters for I_{DD} and R_{th} , and the maximum value for V_{DD} from the application.

For $V_{DD} = 5.5$ V, $R_{th} = 200$ K/W and $I_{DD} = 10$ mA the temperature difference $\Delta T = 11$ K.

For all sensors, the junction temperature T_J is specified. The maximum ambient temperature T_{Amax} can be calculated as:

$$T_{Amax} = T_{Jmax} - \Delta T$$

4.6. EMC and ESD

The HAL810 is designed for a stabilized 5 V supply. Interferences and disturbances conducted along the 12 V on-board system (product standard ISO 7637 part 1) are not relevant for these applications.

For applications with disturbances by capacitive or inductive coupling on the supply line or radiated disturbances, the application circuit shown in Fig. 4–1 is recommended. Applications with this arrangement passed the EMC tests according to the product standard ISO 7637 part 3 (Electrical transient transmission by capacitive or inductive coupling) and part 4 (Radiated disturbances).

Please contact Micronas for the detailed investigation reports with the EMC and ESD results.

5. Programming of the Sensor

5.1. Definition of Programming Pulses

The sensor is addressed by modulating a serial telegram on the supply voltage. The sensor answers with a serial telegram on the output pin.

The bits in the serial telegram have a different bit time for the V_{DD} -line and the output. The bit time for the V_{DD} -line is defined through the length of the Sync Bit at the beginning of each telegram. The bit time for the output is defined through the Acknowledge Bit.

A logical "0" is coded as no voltage change within the bit time. A logical "1" is coded as a voltage change between 50% and 80% of the bit time. After each bit, a voltage change occurs.

5.2. Definition of the Telegram

Each telegram starts with the Sync Bit (logical 0), 3 bits for the Command (COM), the Command Parity Bit (CP), 4 bits for the Address (ADR), and the Address Parity Bit (AP).

There are different telegram formats:

- Write a register (see Fig. 5-2)
After the AP Bit, follow 14 Data Bits (DAT) and the Data Parity Bit (DP). If the telegram is valid and the command has been processed, the sensor answers with an Acknowledge Bit (logical 0) on the output.

- Read a register (see Fig. 5-3)
After evaluating this command, the sensor answers with the Acknowledge Bit, 14 Data Bits, and the Data Parity Bit on the output.
- Programming the EEPROM cells (see Fig. 5-4)
After evaluating this command, the sensor answers with the Acknowledge Bit. After the delay time t_w , the supply voltage rises up to the programming voltage.

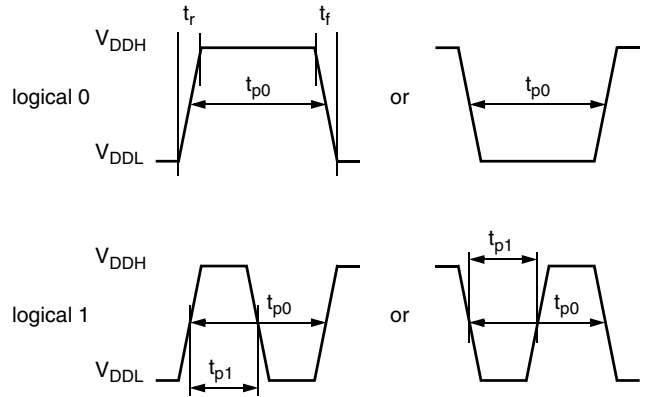

Fig. 5-1: Definition of logical 0 and 1 bit

Table 5-1: Telegram parameters

Symbol	Parameter	Pin	Min.	Typ.	Max.	Unit	Remarks
V_{DDL}	Supply Voltage for Low Level during Programming	1	5	5.6	6	V	
V_{DDH}	Supply Voltage for High Level during Programming	1	6.8	8.0	8.5	V	
t_r	Rise time	1			0.05	ms	
t_f	Fall time	1			0.05	ms	
t_{p0}	Bit time on V_{DD}	1	1.7	1.75	1.8	ms	t_{p0} is defined through the Sync Bit
t_{pOUT}	Bit time on output pin	3	2	3	4	ms	t_{pOUT} is defined through the Acknowledge Bit
t_{p1}	Voltage Change for logical 1	1, 3	50	65	80	%	% of t_{p0} or t_{pOUT}
V_{DDPROG}	Supply Voltage for Programming the EEPROM	1	12.4	12.5	12.6	V	
t_{PROG}	Programming Time for EEPROM	1	95	100	105	ms	
t_{rp}	Rise time of programming voltage	1	0.2	0.5	1	ms	
t_{fp}	Fall time of programming voltage	1	0		1	ms	
t_w	Delay time of programming voltage after Acknowledge	1	0.5	0.7	1	ms	

WRITE

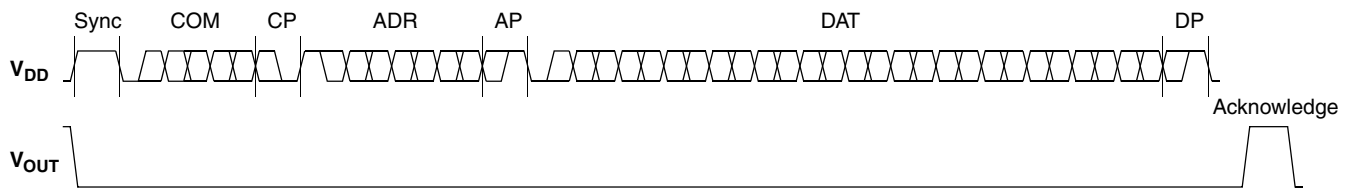

Fig. 5-2: Telegram for coding a Write command

READ

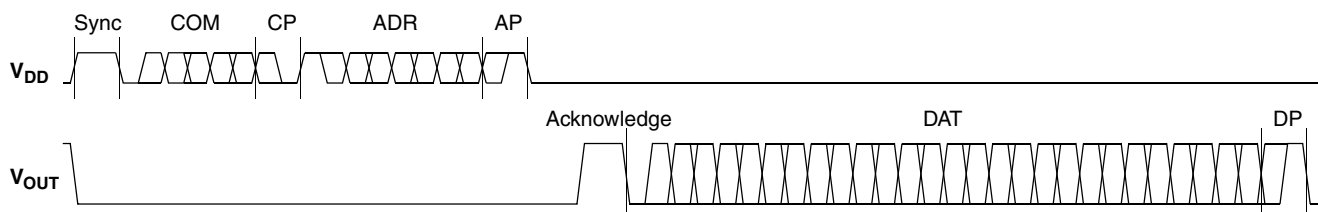

Fig. 5-3: Telegram for coding a Read command

ERASE, PROM, and LOCK

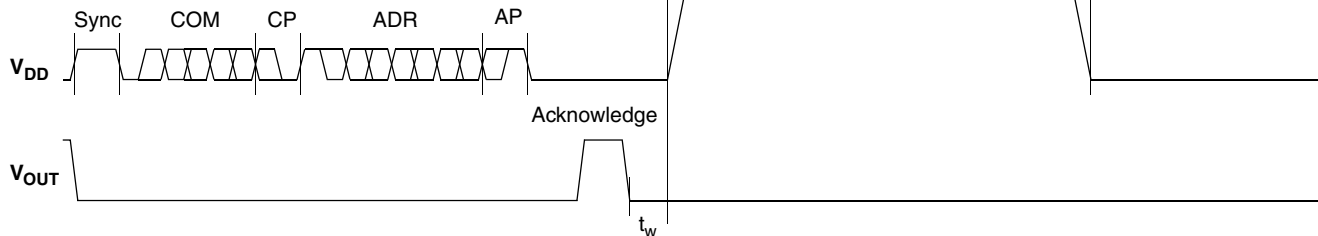

Fig. 5-4: Telegram for coding the EEPROM programming

5.3. Telegram Codes

Sync Bit

Each telegram starts with the Sync Bit. This logical “0” pulse defines the exact timing for t_{p0} .

Command Bits (COM)

The Command code contains 3 bits and is a binary number. Table 5–2 shows the available commands and the corresponding codes for the HAL810.

Command Parity Bit (CP)

This parity bit is “1” if the number of zeros within the 3 Command Bits is uneven. The parity bit is “0”, if the number of zeros is even.

Address Bits (ADR)

The Address code contains 4 bits and is a binary number. Table 5–3 shows the available addresses for the HAL810 registers.

Address Parity Bit (AP)

This parity bit is “1” if the number of zeros within the 4 Address bits is uneven. The parity bit is “0” if the number of zeros is even.

Data Bits (DAT)

The 14 Data Bits contain the register information.

The registers use different number formats for the Data Bits. These formats are explained in Section 5.4.

In the Write command, the last bits are valid. If, for example, the TC register (6 bits) is written, only the last 6 bits are valid.

In the Read command, the first bits are valid. If, for example, the TC register (6 bits) is read, only the first 6 bits are valid.

Data Parity Bit (DP)

This parity bit is “1” if the number of zeros within the binary number is even. The parity bit is “0” if the number of zeros is uneven.

Acknowledge

After each telegram, the output answers with the Acknowledge signal. This logical “0” pulse defines the exact timing for t_{pOUT} .

Table 5–2: Available commands

Command	Code	Explanation
READ	2	read a register
WRITE	3	write a register
PROM	4	program all nonvolatile registers (except the lock bits)
ERASE	5	erase all nonvolatile registers (except the lock bits)
LOCK	7	lock the whole device and disable programming

5.4. Number Formats

Binary number:

The most significant bit is given as first, the least significant bit as last digit.

Example: 101001 represents 41 decimal.

Signed binary number:

The first digit represents the sign of the following binary number (1 for negative, 0 for positive sign).

Example: 0101001 represents +41 decimal
1101001 represents -41 decimal

Two-complementary number:

The first digit of positive numbers is "0", the rest of the number is a binary number. Negative numbers start with "1". In order to calculate the absolute value of the number, calculate the complement of the remaining digits and add "1".

Example: 0101001 represents +41 decimal
1010111 represents -41 decimal

Table 5-3: Available register addresses

Register	Code	Data Bits	Format	Customer	Remark
MIN-DUTY	1	10	binary	read/write/program	Minimum Duty Cycle
MAX-DUTY	2	11	binary	read/write/program	Maximum Duty Cycle
DCOQ	3	11	two compl. binary	read/write/program	Output Duty Cycle at zero ADC-Readout
DCSENSITIVITY	4	14	signed binary	read/write/program	Increase of Output Duty Cycle with ADC-Readout
MODE	5	6	binary	read/write/program	Range and filter settings
LOCKR	6	1	binary	lock	Lock Bit for customer registers
ADC-READOUT	7	14	two compl. binary	read	Output of A/D converter (internal magnetic signal)
TC	11	6	signed binary	read/write/program	Temperature compensation coefficient
TCSQ	12	5	binary	read/write/program	Temperature compensation coefficient

Table 5-4: Micronas registers (read only for customers)

Register	Code	Data Bits	Format	Remark
OFFSET	8	5	two compl. binary	ADC offset adjustment
FOSCAD	9	5	binary	Oscillator frequency adjustment
SPECIAL	13	8		special settings

5.5. Register Information

MIN-DUTY

The register range is from 0 up to 1023.

- The register value is calculated with:

$$MIN-DUTY = \frac{Min-Duty}{100\%} * 2048$$

MAX-DUTY

- The register range is from 0 up to 2047.
- The register value is calculated with:

$$MAX-DUTY = \frac{Max-Duty}{100\%} * 2048$$

DCOQ

- The register range is from –1024 up to 1023.
- The register value is calculated with:

$$DCOQ = \frac{DC_{OQ}}{100\%} * 1024$$

DCSENSITIVITY

- The register range is from –8192 up to 8191.
- The register value is calculated with:

$$DCSENSITIVITY = DCSensitivity * 2048$$

TC and TCSQ

- The TC register range is from –31 up to 31.
- The TCSQ register range is from 0 up to 31.

Please refer Section 4.3. on page 22 for the recommended values.

MODE

- The register range is from 0 up to 63 and contains the settings for FILTER and RANGE:

$$MODE = FILTER * 8 + RANGE$$

Please refer Section 2.2. on page 7 for the available FILTER and RANGE values.

ADC-READOUT

- This register is read only.
- The register range is from –8192 up to 8191.

5.6. Programming Information

If the content of any register (except the lock registers) is to be changed, the desired value must first be written into the corresponding RAM register. Before reading out the RAM register again, the register value must be permanently stored in the EEPROM.

Permanently storing a value in the EEPROM is done by first sending an ERASE command followed by sending a PROM command. The address within the ERASE and PROM commands is not important. ERASE and PROM act on all registers in parallel.

If all HAL810 registers are to be changed, all writing commands can be sent one after the other, followed by sending one ERASE and PROM command at the end.

During all communication sequences, the customer has to check if the communication with the sensor was successful. This means that the acknowledge and the parity bits sent by the sensor have to be checked by the customer. If the Micronas programmer board is used, the customer has to check the error flags sent from the programmer board.

Note: For production and qualification tests, it is strongly recommended to set the LOCK bit after final adjustment and programming of HAL810. The LOCK function is active after the next power-up of the sensor. Micronas also recommends sending an additional ERASE command after sending the LOCK command. The success of the Lock Process should be checked by reading at least one sensor register after locking and/or by an analog check of the sensors output signal. Electrostatic Discharges (ESD) may disturb the programming pulses. Please take precautions against ESD.

6. Data Sheet History

1. Data Sheet: "HAL 810 Programmable Linear Hall Effect Sensor", Aug. 16, 2002, 6251-536-1DS. First release of the data sheet.
2. Data Sheet: "HAL 810 Programmable Linear Hall Effect Sensor", Nov. 22, 2002, 6251-536-2DS. Second release of the data sheet. Major changes:
 - Fig. 2–3: Diagram "Details of EEPROM and Digital Signal Processing" changed
 - Fig. 2–5: Diagram "Example for output characteristics" changed
 - DCOQ register programmable from –100% to 100% in steps of 0.0976%
 - Clamping function: minimum duty cycle programmable between 0% and 50% in steps of 0.0488%, maximum duty cycle programmable between 0% and 100% in steps of 0.0488%
 - Changes in Register Information.
3. Data Sheet: "HAL 810 Programmable Linear Hall Effect Sensor", June 24, 2004, 6251-536-3DS. Third release of the data sheet. Major changes:
 - new package diagram for TO92UT-1
 - package diagram for TO92UT-2 added
 - ammpack diagrams for TO92UT-1/-2 added
 - Section 4.2. "Measurement of a PWM Output Signal" added

Micronas GmbH
Hans-Bunte-Strasse 19
D-79108 Freiburg (Germany)
P.O. Box 840
D-79008 Freiburg (Germany)
Tel. +49-761-517-0
Fax +49-761-517-2174
E-mail: docservice@micronas.com
Internet: www.micronas.com

Printed in Germany
Order No. 6251-536-3DS

All information and data contained in this data sheet are without any commitment, are not to be considered as an offer for conclusion of a contract, nor shall they be construed as to create any liability. Any new issue of this data sheet invalidates previous issues. Product availability and delivery are exclusively subject to our respective order confirmation form; the same applies to orders based on development samples delivered. By this publication, Micronas GmbH does not assume responsibility for patent infringements or other rights of third parties which may result from its use.

Further, Micronas GmbH reserves the right to revise this publication and to make changes to its content, at any time, without obligation to notify any person or entity of such revisions or changes.

No part of this publication may be reproduced, photocopied, stored on a retrieval system, or transmitted without the express written consent of Micronas GmbH.