

# MN6576H

## Low Power 9-Bit CMOS A/D Converter for Image Processing

### ■ Overview

The MN6576H is a high-speed 9-bit CMOS analog-to-digital converter for image processing applications.

It uses a half flash structure based on chopper comparators and achieves both high speed and low power consumption with multiplexing.

It provides separate power supply pins for the circuits driving the low-voltage digital output pins.

### ■ Features

- Maximum conversion rate: 16 MSPS (min.)
- Linearity error:  $\pm 2.5$  LSB (typ.)
- Differential linearity error:  $\pm 0.6$  LSB (typ.)
- Power supply voltage: 5.0 V or 3.3 V
- Power consumption: 120 mW (typ.) ( $f_{\text{CLK}}=16$  MHz)

### ■ Applications

- Digital television receivers
- Digital video equipment
- Digital image processing equipment

### ■ Pin Assignment

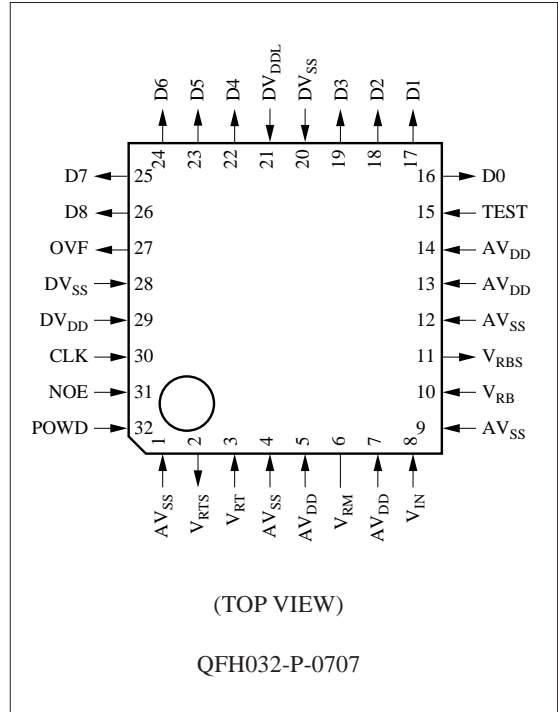

■ Block Diagram

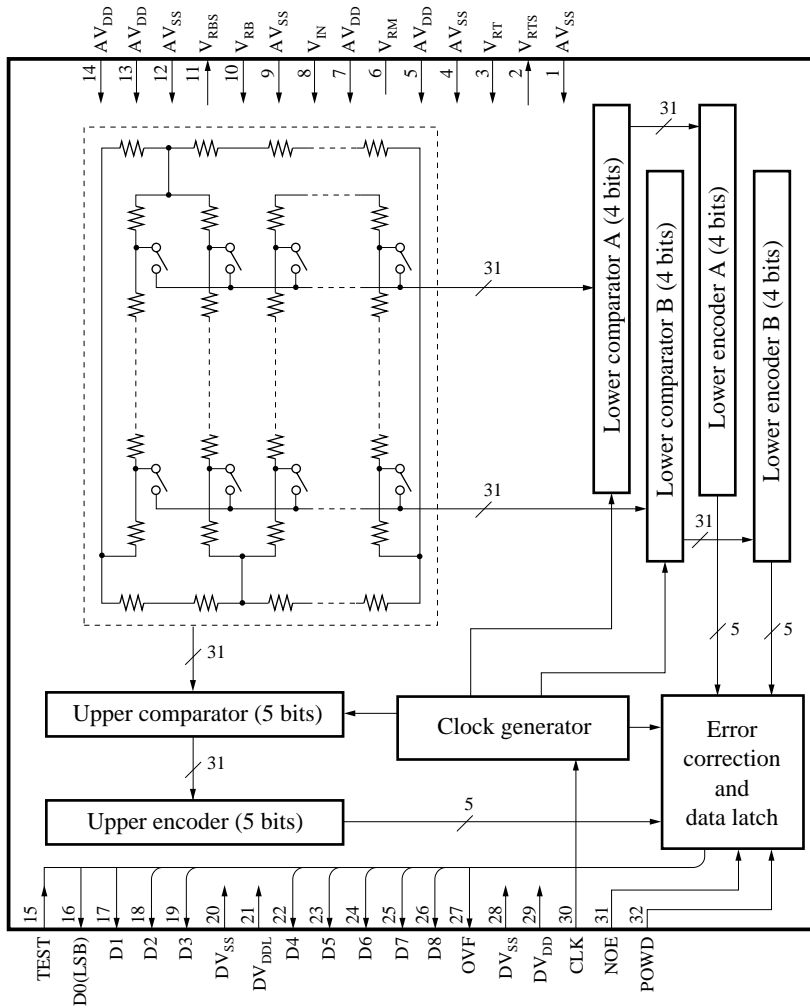

### ■ Pin Descriptions

Pin No.	Symbol	Function Description
1	AV <sub>SS</sub>	Ground for analog circuits
2	V <sub>RTS</sub>	Reference voltage power supply (TOP)
3	V <sub>RT</sub>	Reference voltage input (TOP)
4	AV <sub>SS</sub>	Ground for analog circuits
5	AV <sub>DD</sub>	Power supply for analog circuits
6	V <sub>RM</sub>	Intermediate reference voltage
7	AV <sub>DD</sub>	Power supply for analog circuits
8	V <sub>IN</sub>	Analog signal input
9	AV <sub>SS</sub>	Ground for analog circuits
10	V <sub>RB</sub>	Reference voltage power supply (BOTTOM)
11	V <sub>RBS</sub>	Reference voltage input (BOTTOM)
12	AV <sub>SS</sub>	Ground for analog circuits
13	AV <sub>DD</sub>	Power supply for analog circuits
14	AV <sub>DD</sub>	Power supply for analog circuits
15	TEST	Test mode selection
16	D0	Digital code output (LSB)
17	D1	Digital code output
18	D2	Digital code output
19	D3	Digital code output
20	DV <sub>SS</sub>	Ground for digital circuits
21	DV <sub>DDL</sub>	Power supply for low-voltage digital outputs
22	D4	Digital code output
23	D5	Digital code output
24	D6	Digital code output
25	D7	Digital code output
26	D8	Digital code output (MSB)
27	OVF	Overflow output
28	DV <sub>SS</sub>	Ground for digital circuits
29	DV <sub>DD</sub>	Power supply for digital circuits
30	CLK	Sampling clock
31	NOE	Output enable
32	POWD	Power down mode selection

**■ Absolute Maximum Ratings**  $T_a=25^\circ\text{C}$ 

Parameter	Symbol	Rating	Unit
Power supply voltage	$V_{DD}$	-0.3 to +7.0	V
Power supply voltage for digital output circuits	$DV_{DDL}$	-0.3 to $V_{DD}+0.3$	V
Input voltage	$V_I$	-0.3 to $V_{DD}+0.3$	V
Output voltage	$V_O$	-0.3 to $V_{DD}+0.3$	V
Operating ambient temperature	$T_{opr}$	-20 to +70	$^\circ\text{C}$
Storage temperature	$T_{stg}$	-55 to +125	$^\circ\text{C}$

**■ Recommended Operating Conditions**  $V_{DD}=AV_{DD}=DV_{DD}=4.5\text{V}$ ,  $DV_{DDL}=3.0\text{V}$ ,  $V_{SS}=AV_{SS}=DV_{SS}=0\text{V}$ ,  $T_a=25^\circ\text{C}$ 

Parameter	Symbol	min	typ	max	Unit
Power supply voltage	$V_{DD}$	4.50	5.00	5.25	V
Power supply voltage for digital output circuits	$DV_{DDL}$	3.0		3.6	V
Digital input voltage	"H" level	$V_{IH}$	2.4	$V_{DD}$	V
	"L" level	$V_{IL}$	$V_{SS}$	0.8	V
Reference voltage	"H" level	$V_{RT}$	3.0	$V_{DD}$	V
	"L" level	$V_{RB}$	$V_{SS}$	2.0	V
Clock	"H" level pulse width	$t_{WH}$	25		ns
	"L" level pulse width	$t_{WL}$	25		ns
Analog input voltage	$V_{AIN}$	$V_{SS}$		$V_{DD}$	V

**■ Electrical Characteristics**  $V_{DD}=AV_{DD}=DV_{DD}=4.5\text{V}$ ,  $DV_{DDL}=3.0\text{V}$ ,  $AV_{SS}=DV_{SS}=0\text{V}$ ,  $T_a=25^\circ\text{C}$ 

Parameter	Symbol	Conditions	min	typ	max	Unit
Power consumption	$P_C$	$V_{DD}=5.0\text{V}$ , $DV_{DDL}=3.3\text{V}$ , $f_{CLK}=16\text{MSPS}$ (not including reference current)		120	150	mW
Resolution	RES			9		bit
Linearity error	$E_L$	$f_{CLK}=16\text{MSPS}$		$\pm 2.5$	$\pm 3.5$	LSB
Differential linearity error	$E_D$	$V_{RT}=3.3\text{V}$ $V_{RB}=1.3\text{V}$		$\pm 0.6$	$\pm 1.0$	LSB
Maximum conversion rate	$F_{C(max.)}$		16			MSPS
Clock frequency	$f_{CLK}$		1		16	MHz
Analog input dynamic range	$D_R$		2		$V_{RT}-V_{RB}$	V
Output current	"H" level	$I_{OH}$			-2	mA
	"L" level	$I_{OL}$		2		mA
Output delay time	$t_d$	$V_{DD}=5.0\text{V}$ , $DV_{DDL}=3.3\text{V}$ , $C_L=10\text{pF}$	10	30	45	ns
Analog input capacitance	$C_I$	$V_{DD}=5.0\text{V}$		26		pF

**■ Timing Chart**

The chip samples the analog input at the falling edge of the clock signal and provides the corresponding digital output 2.5 clock cycles later at the rising edge of the clock signal.

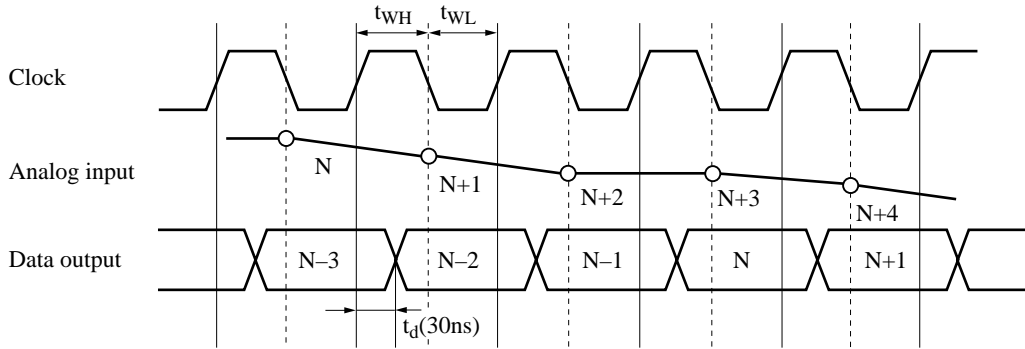

Note: The circles indicate analog signal sampling points.

■ Package Dimensions (Unit:mm)

QFH032-P-0707

