

# TC4078BP/BF

C<sup>2</sup>MOS DIGITAL INTEGRATED CIRCUIT  
SILICON MONOLITHIC

## TC4078BP/TC4078BF 8-INPUT NOR/OR GATE

The TC4078BP/BF is 8-bit positive logic NOR/OR gate. Since each output of this gate is provided with a buffer, the input/output voltage characteristics have been improved, allowing noise immunity to be elevated; thus, the variation of propagation delay time due to the increase in load capacity is kept to the minimum.

### MAXIMUM RATINGS

CHARACTERISTIC	SYMBOL	RATING	UNIT
DC Supply Voltage	V <sub>DD</sub>	V <sub>SS</sub> -0.5 ~ V <sub>SS</sub> +2.0	V
Input Voltage	V <sub>IN</sub>	V <sub>SS</sub> -0.5 ~ V <sub>DD</sub> +0.5	V
Output Voltage	V <sub>OUT</sub>	V <sub>SS</sub> -0.5 ~ V <sub>DD</sub> +0.5	V
DC Input Current	I <sub>IN</sub>	±10	mA
Power Dissipation	P <sub>D</sub>	300(DIP)/180(MFP)	mW
Operating Temperature Range	T <sub>A</sub>	-40 ~ 85	°C
Storage Temperature Range	T <sub>stg</sub>	-65 ~ 150	°C
Lead Temp./Time	T <sub>sol</sub>	260°C · 10scc	

### LOGIC DIAGRAM

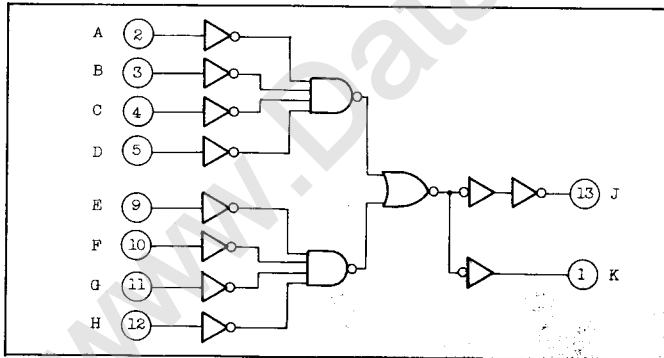

### RECOMMENDED OPERATING CONDITIONS (V<sub>SS</sub>=0V)

CHARACTERISTIC	SYMBOL	MIN.	TYP.	MAX.	UNIT
DC Supply Voltage	V <sub>DD</sub>	3	-	18	V
Input Voltage	V <sub>IN</sub>	0	-	V <sub>DD</sub>	V

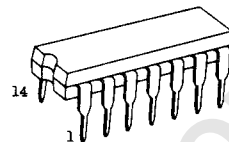

DIP14 (3D14A-P)

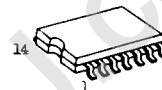

MFP14 (F14GB-P)

### PIN ASSIGNMENT

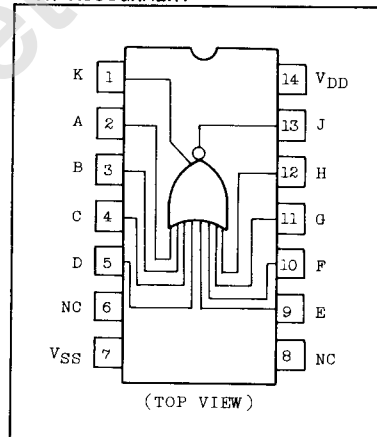

STATIC ELECTRICAL CHARACTERISTICS (V<sub>SS</sub>=0V)

CHARACTERISTIC	SYM-BOL	TEST CONDITION	V <sub>DD</sub> (V)	-40°C		25°C			85°C		UNIT	
				MIN.	MAX.	MIN.	TYP.	MAX.	MIN.	MAX.		
High-Level Output Voltage	V <sub>OH</sub>	I <sub>OUT</sub>   < 1μA V <sub>IN</sub> =V <sub>SS</sub> , V <sub>DD</sub>	5	4.95	-	4.95	5.00	-	4.95	-	V	
			10	9.95	-	9.95	10.00	-	9.95	-		
			15	14.95	-	14.95	15.00	-	14.95	-		
Low-Level Output Voltage	V <sub>OL</sub>	I <sub>OUT</sub>   < 1μA V <sub>IN</sub> =V <sub>SS</sub> , V <sub>DD</sub>	5	-	0.05	-	0.00	0.05	-	0.05	V	
			10	-	0.05	-	0.00	0.05	-	0.05		
			15	-	0.05	-	0.00	0.05	-	0.05		
Output High Current	I <sub>OH</sub>	V <sub>OH</sub> =4.6V	5	-0.61	-	-0.51	-1.0	-	-0.42	-	mA	
		V <sub>OH</sub> =2.5V	5	-2.5	-	-2.1	-4.0	-	-1.7	-		
		V <sub>OH</sub> =9.5V	10	-1.5	-	-1.3	-2.2	-	-1.1	-		
		V <sub>OH</sub> =13.5V	15	-4.0	-	-3.4	-9.0	-	-2.8	-		
		V <sub>IN</sub> =V <sub>SS</sub> , V <sub>DD</sub>										
Output Low Current	I <sub>OL</sub>	V <sub>OL</sub> =0.4V	5	0.61	-	0.51	1.5	-	0.42	-	mA	
		V <sub>OL</sub> =0.5V	10	1.5	-	1.3	3.8	-	1.1	-		
		V <sub>OL</sub> =1.5V	15	4.0	-	3.4	15.0	-	2.8	-		
		V <sub>IN</sub> =V <sub>SS</sub> , V <sub>DD</sub>										
Input High Voltage	V <sub>IH</sub>	V <sub>OUT</sub> =0.5V, 4.5V	5	3.5	-	3.5	2.75	-	3.5	-	V	
		V <sub>OUT</sub> =1.0V, 9.0V	10	7.0	-	7.0	5.5	-	7.0	-		
		V <sub>OUT</sub> =1.5V, 13.5V	15	11.0	-	11.0	8.25	-	11.0	-		
		I <sub>OUT</sub>   < 1μA										
Input Low Voltage	V <sub>IL</sub>	V <sub>OUT</sub> =0.5V, 4.5V	5	-	1.5	-	2.25	1.5	-	1.5	V	
		V <sub>OUT</sub> =1.0V, 9.0V	10	-	3.0	-	4.5	3.0	-	3.0		
		V <sub>OUT</sub> =1.5V, 13.5V	15	-	4.0	-	6.75	4.0	-	4.0		
		I <sub>OUT</sub>   < 1μA										
Input Current	"H" Level	I <sub>IH</sub>	V <sub>IH</sub> =18V	18	-	0.1	-	10 <sup>-5</sup>	0.1	-	1.0	μA
	"L" Level	I <sub>IL</sub>	V <sub>IL</sub> =0V	18	-	-0.1	-	-10 <sup>-5</sup>	-0.1	-	-1.0	
Quiescent Device Current	I <sub>DD</sub>	V <sub>IN</sub> =V <sub>SS</sub> , V <sub>DD</sub> *	5	-	0.25	-	0.001	0.25	-	7.5	μA	
			10	-	0.5	-	0.001	0.5	-	15		
			15	-	1.0	-	0.002	1.0	-	30		

\* All valid input combinations.

# TC4078BP/BF

DYNAMIC ELECTRICAL CHARACTERISTICS (Ta=25°C, VSS=0V, CL=50pF)

CHARACTERISTIC	SYMBOL	TEST CONDITION	VDD(V)	MIN.	TYP.	MAX.	UNIT
Output Transition Time (Low to High)	t <sub>TLH</sub>		5	-	80	200	ns
			10	-	50	100	
			15	-	40	80	
Output Transition Time (High to Low)	t <sub>THL</sub>		5	-	80	200	
			10	-	50	100	
			15	-	40	80	
Propagation Delay Time	t <sub>pLH</sub> t <sub>pHL</sub>		5	-	170	300	ns
			10	-	70	140	
			15	-	50	110	
Input Capacitance	C <sub>IN</sub>			-	5	7.5	pF

## CIRCUIT AND WAVEFORM FOR MEASUREMENT OF DYNAMIC CHARACTERISTICS

