

#### Features

- Fully programmable line impedance, network balance impedance and gains
- Programmable loop current with long loop capability
- 2-4 Wire conversion
- Power down and wake up
- Battery feed to line with wide operating range
- Off-hook and dial pulse detection
- Over-current protection
- Integral ringing amplifier with auto ring trip
- Tip/Ring reversal
- Meter pulse injection
- On-hook transmission to the line capability
- Relay driver
- Short loop ringing capability with low voltage DC supply

#### Applications

Line interface for:

- PABX/Key Telephone System
- Analog Terminal Adaptors
- Pair Gain System
- Fibre in the Loop/Wireless Local Loop

DS5037

ISSUE 5

October 2001

#### Ordering Information

MH88617AV-PI 21PIN SIL Package

-40°C to 85°C

#### Description

The Zarlink MH88617 is a highly featured, low cost Subscriber Line Interface Circuit (SLIC). It provides a total analog transmission and signalling link between a CODEC and a subscriber line. All functions are integrated into a single thick film hybrid module, which provides high reliability and optimum circuit design needing a minimum of external components.

The line impedance, network balance impedance, gain and loop current are all externally programmable, making the device suitable for a wide range of applications worldwide.

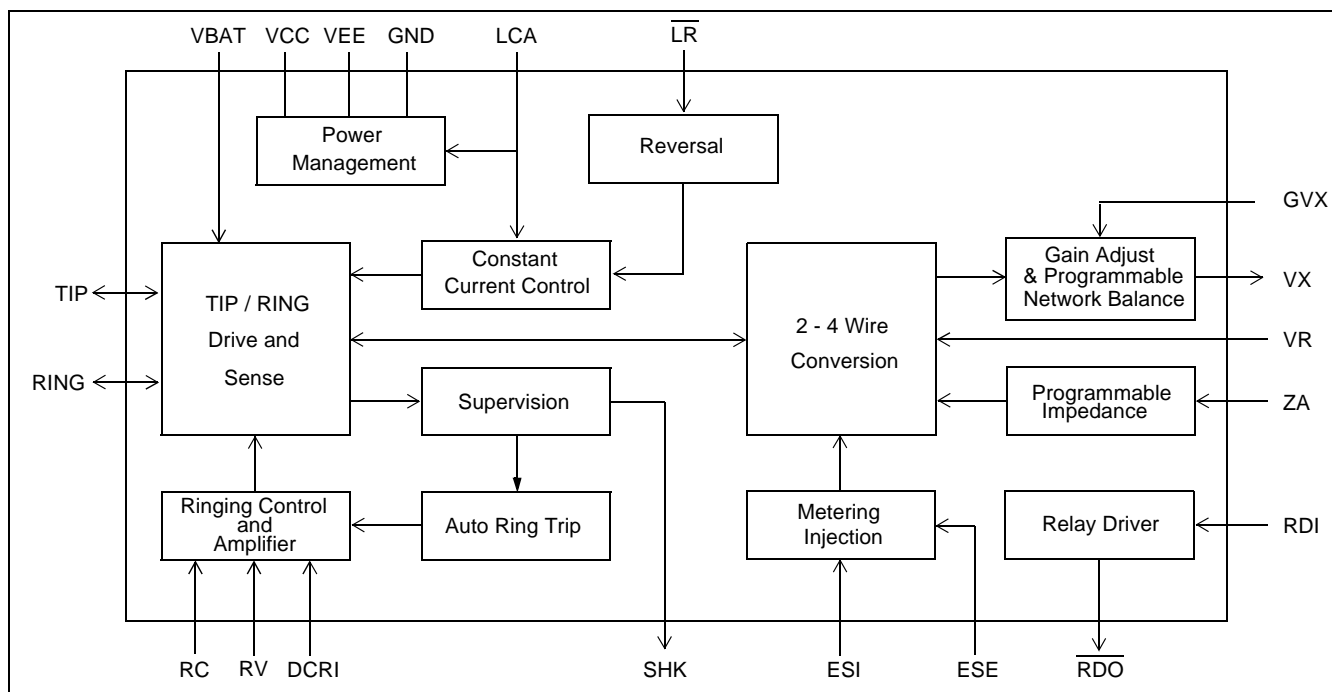

Figure 1 - Functional Block Diagram

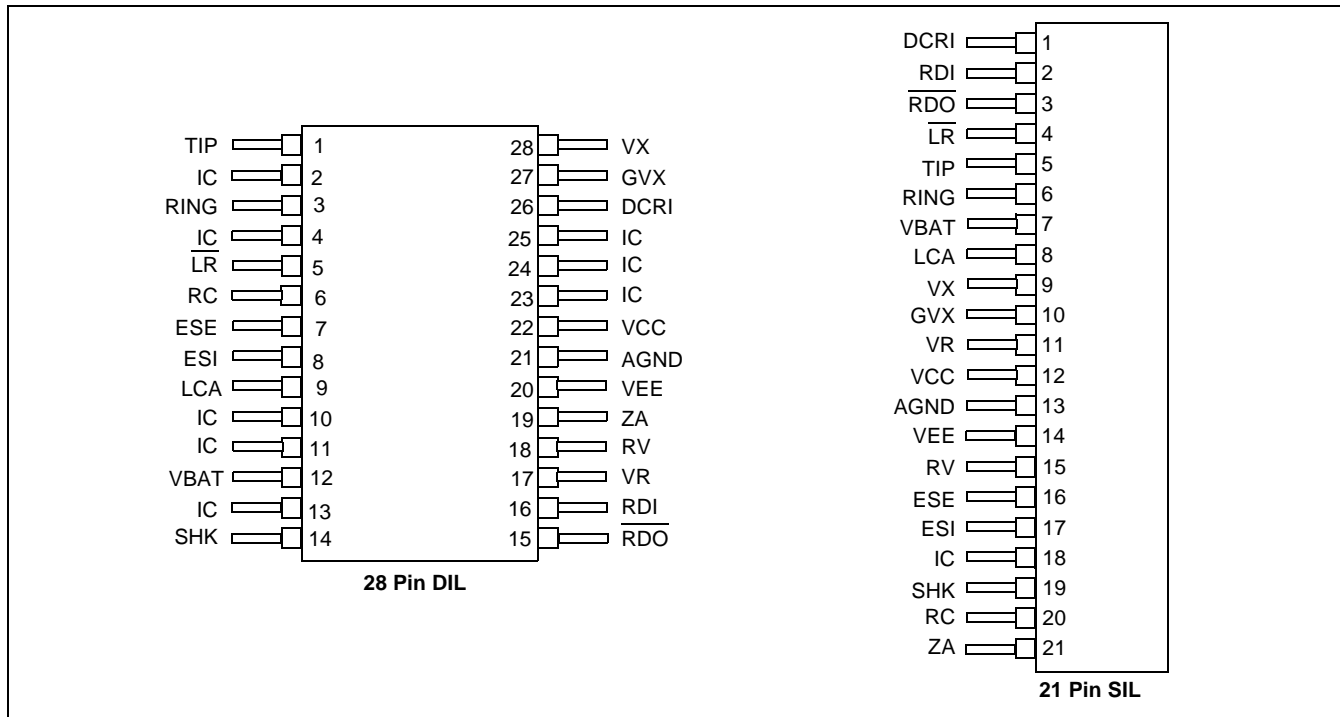

Figure 2 - Pin Connections

Pin Description

28 Pin DIL	21 Pin SIL	Name	Description
26	1	DCRI	<b>DC Ringing Voltage Input.</b> A continuous DC voltage is applied to this pin. This voltage is the positive supply rail for the internal ringing amplifier.
16	2	RDI	<b>Relay Driver Input.</b> Relay driver control pin.
15	3	RDO	<b>Relay Driver Output.</b> Open collector relay driver output.
5	4	LR	<b>Line Reversal.</b> Setting this pin to a logic 0 will perform a line reversal. This pin must be connected to logic 1 for normal operation.
1	5	TIP	<b>Tip Lead.</b> Connects to the "Tip" lead of the subscriber line.
3	6	RING	<b>Ring Lead.</b> Connects to the "Ring" lead of the subscriber line.
12	7	VBAT	<b>Battery Voltage.</b> Battery supply for the subscriber line. Typically -48V DC is applied to this pin.
9	8	LCA	<b>Loop Current Adjust.</b> The loop current is programmed by connecting a resistor between this pin and the VCC or AGND pins. Leaving this pin open circuit defaults the loop current to 24mA. Setting this pin to 0V will apply power down.
28	9	VX	<b>Transmit Signal (Output).</b> 4-wire analog signal from the SLIC.
27	10	GVX	<b>Transmit Gain Adjust.</b> The transmit gain can be programmed by connecting a resistor between this pin and VX. The Network Balance Impedance can also be programmed by connecting external matching components from this pin to VR.
17	11	VR	<b>Receive Signal (Input).</b> 4-wire analog signal to the SLIC.
22	12	VCC	<b>Positive Supply Voltage.</b> +5V.
21	13	AGND	<b>Analog Ground.</b> Ground path for the subscriber line and all DC power supplies, normally connected to system ground.
20	14	VEE	<b>Negative Supply Voltage.</b> -5V.

**Pin Description (continued)**

28 Pin DIL	21 Pin SIL	Name	Description
18	15	RV	<b>Ring Voltage.</b> A low level AC sinusoid is applied to this pin. This signal is amplified and output from TIP/RING to the line as the ringing signal, when RC is at logic 1. <u>This pin should be driven with a low impedance AGND centred source.</u>
7	16	ESE	<b>External Signal Enable.</b> Meter pulse input enable.
8	17	ESI	<b>External Signal Input.</b> Meter pulse input.
2, 4,10, 11,13, 23, 25,24	18	IC	<b>Internal Connection.</b> No connection should be made to this pin.
14	19	SHK	<b>Switch Hook Detect (Output).</b> A logic 1 at this pin indicates when the subscriber has gone Off-Hook.
6	20	RC	<b>Ring Control (Input).</b> A logic 1 will cause the ringing voltage to be applied to the line.
19	21	ZA	<b>Line Impedance.</b> Connect passive components from ZA to ground to match input and line impedance.

**Functional Description**

The MH88617 is a Subscriber Line Interface Circuit (SLIC) used to provide an analog interface between the 4-wire connection and the 2-wire subscriber line of a communications system.

It provides powering of the subscriber line along with signalling, control and status circuits. This combines to provide a comprehensive line and interface solution in applications such as PABX, Key Systems, Analog Terminal Adapters, Pair Gain Systems, Fibre in the Loop and Wireless Local Loop.

**External Protection Circuit**

An External Protection Circuit assists in preventing damage to the device and the subscriber equipment, due to over-voltage conditions (see Figure 3). Also reference MSAN-156.

**2-4 Wire Conversion**

The SLIC converts the balanced 2-Wire input at Tip and Ring to a ground referenced signal at VX. The device converts the ground referenced signal input at VR to a balanced 2-Wire signal across Tip and Ring.

Normally the VX and VR pins connect to a Codec that interfaces the analog signal to a digital network. During full duplex transmission, the signal at

Tip and Ring consists of both the signal from the device to the line and the signal from the line to the device. The signal input at VR being sent to the line, must not appear at the output VX. In order to prevent this, the device has an internal cancellation circuit, the measure of this attenuation is Transhybrid Loss (THL).

The MH88617 has the ability to transmit analog signals from VR through to Tip and Ring when on-hook. This can be used when sending caller line identification information.

**Battery Feed and Loop Current Adjust**

The MH88617 has an active feedback circuit to regulate the DC current to the subscriber line. This current is programmable over a wide range via the LCA pin. With LCA open circuit the current will be set to 24mA. This can be increased up to 55mA by connecting a resistor between LCA and VCC or reduced down to 14mA by connecting a resistor between LCA and AGND. MSAN-156 shows a table of resistor values and loop current.

The line driver stage is biased between +5V and -48V DC. Therefore it should be noted that loop current will flow in the +5V supply, this must be taken into consideration when choosing the +5V supply.

The device will operate over a very wide VBAT supply range but care must be taken when programming the constant current that the maximum

power dissipation is not exceeded. For the majority of applications this will not be a problem, however the device could be damaged if used to drive a very short line with the maximum battery voltage and maximum programmable loop current.

For very long loops the constant current drive reverts to a constant voltage source. A graph of loop current versus line resistance is shown in Figure 4.

Under fault conditions, Tip or Ring are protected from short circuits to ground when the current exceeds the protection trip threshold. Under these circumstances, the SLIC will go into a power down mode and periodically check the line status until the fault has been removed. Thereby minimizing power dissipation. The SLIC will revert to an operational state once the fault is removed.

### Ringing Amplification

The MH88617 incorporates an internal ringing amplifier circuit. A balanced ringing signal is applied across Tip and Ring, when a DC voltage is connected to the DCRI pin, a low level sinusoidal signal is applied to RV and RC is set to logic 1. The ringing voltage is approximately 50 times the signal at RV. The gain depends on the ringer load and impedance at ZA. If an absolute gain is required, a transistor can be fitted across ZA to give 42.

The SLIC also has the ability to provide ringing on short loops without the need for a high voltage DCRI supply. This is achieved by connecting the DCRI pin to a low voltage supply such as +5V or +12V providing the subscriber equipment ringing detector has a low enough sensitivity threshold. In this application the input at RV needs to be a square wave (refer MSAN-156).

The SLIC has an automatic ring-trip circuit that ensures the ringing is removed when the subscriber goes off-hook. However the user must still insure RC is taken to logic 0 when SHK signals the subscriber has gone off-hook.

### Programmable Input Impedance

By connecting external passive components between ZA and ground (AGND) the device's input impedance can be set to match the line impedance. As shown in Figure 3 and Table 1. A more comprehensive list is given in MSAN-156.

### Programmable Network Balance

The network balance of the device can be programmed by connecting external passive components between GVX and VR, as shown in Figure 3 and Table 1.

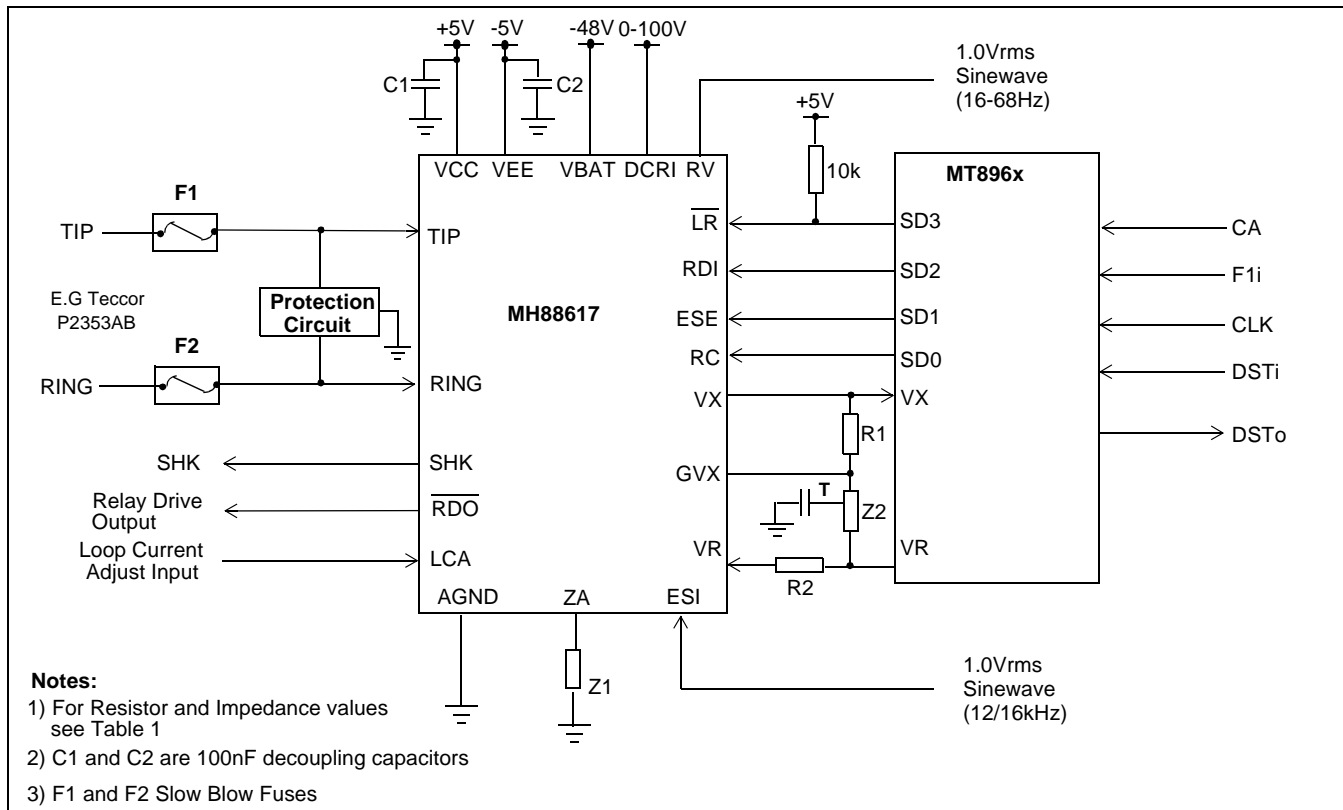

Figure 3 - Typical Application Circuit

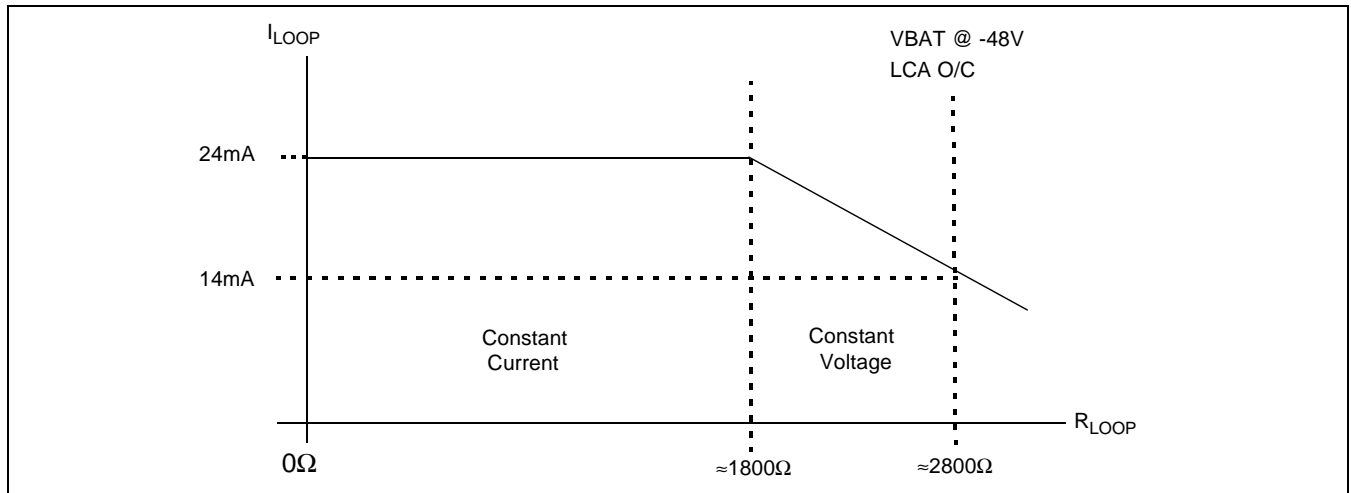

Figure 4 - Loop Current vs. Line Resistance

Table 1 gives table of values for some common applications. A more comprehensive list is given in MSAN-156.

### Programmable Transmit and Receive Gain

The transmit gain from Tip and Ring to VX can be programmed by connecting a resistor between GVX and VX. Similarly the Receive Gain from VR to Tip and Ring can be programmed by connecting an impedance in series with VR as shown in Figure 3 and Table 1. Refer to MSAN-156 for additional impedances.

### Off-Hook and Dial Pulse Detection

The switch hook detect output (SHK) goes to a logic 1, when loop current is above the detect threshold (see DC Electrical Characteristics). This occurs when the subscriber's equipment seizes the line to initiate a call or answer a call. When loop disconnect dialling is being used, SHK pulses to logic 0 to indicate the digits being dialled. This output should be debounced by the system software.

During On-hook transmission SHK remains at logic 0.

### Reversal

During normal operation i.e.  $\overline{LR}$  connected to logic 1, the DC voltage on Tip is positive with respect to Ring. This can be reversed by applying a logic 0 to the Line Reversal pin ( $\overline{LR}$ ). This feature is used for signalling. The SLIC is functional during reversal but

for optimum performance forward operation is recommended.

### Meter-Pulse Injection

If the External Signal Enable (ESE) is taken to logic 1 and a 12kHz or 16kHz Meter Pulse signal is applied to the ESI pin then this signal will be amplified and output across Tip and Ring. This is used for calculating the cost of a telephone call.

The gain of the meter pulse signal varies with programmed input impedance e.g. with the input impedance programmed for 600Ω and a 200Ω AC load applied across Tip and Ring the ESI signal will be amplified by a factor of 2.

Some applications require the 12/16 kHz meter pulse signal to be ramped before being input at ESI.

### Power Down

If AGND is applied to LCA pin the MH88617 will enter a power down mode where the internal circuitry is turned off and the power consumption is reduced. This can be used to conserve power when the line is inactive.

If the system wants to initiate a call the AGND must be removed from the LCA before the ringing signal is transmitted.

If the subscriber initiates a call by seizing the line, SHK will go to logic 1. The system should monitor this and respond by removing the AGND from LCA causing the device to wake up.

**Relay Driver**

An open collector output is provided as a driver for an external relay. Applying 5V to the RDI pin will cause the RDO pin to sink current to ground. A flyback diode must be connected across the relay coil to protect this output.

The DC load of the relay coil must not exceed 20Ω.

**Mechanical Data**

See Figure 11, 12, 13, and 14 for details of the mechanical specification.

Line Conditions				Programming Components			
Line Impedance	Balance Impedance	VX Gain	VR Gain	Z1	Z2	R1	R2
600Ω	600Ω	0dB	0dB	30k	18k + 18k T 470pF	36k	110k
600Ω	600Ω	4dB	-4dB	30k	28k5 + 28k5 T 330pF	57k	180k
600Ω	350Ω+1KΩ //210nF	0dB	0dB	60k//30k	18k + 18k T (10k3+5.3nF)	36k	110k
370Ω+620Ω/ /310nF	370Ω+620Ω //310nF	0dB	0dB	40k//(1.2nF+ 32k5)	18k + 18k T 100pF	36k	(124k//1.5nF) + 64k
220Ω+820Ω/ /115nF	220Ω+820Ω //115nF	0dB	0dB	41k//(630pF+3k)	36k	36k	(164k//550pF) + 34k
900Ω	900Ω	0dB	0dB	38k9	18k+18k T 330pF	36k	174k
270Ω+750Ω/ /150nF	270Ω+750Ω //150nF	0dB	0dB	40k3//(11k5+730pF)	18k+18k T 100pF	36k	(150k//760pF) + 48k5

**Table 1 - External Programming Components**

Note: The programming component values shown, give the optimum performance in terms of gain accuracy, return loss and THL. A compromise is these values can be made if a reduction in performance is acceptable.

**Absolute Maximum Ratings\*** - All voltages are with respect to AGND unless otherwise specified.

	Parameter	Sym	Min	Max	Units
1	DC Supply Voltage	$V_{CC}$ $V_{EE}$	-0.3 -6	6 0.3	V V
2	DC Battery Voltage	$V_{BAT}$	-75	0.3	V
3	DC Ringing Voltage	$V_{DCRI}$	-0.7	150	V
4	DC Reference Voltage	LCA	-0.3	6	V
5	Relay Driver Voltage	RDO	-0.3	15	V
6	Relay Driver Coil Resistance		230		$\Omega$ (for 5V relay)
7	Ringing Input Voltage	RV	0	3	Vrms Note 1
8	Maximum Power Handling Capacity (Off-hook)  @ 25°C @ 70°C @ 85°C	PD		2250 1530 1290	mW mW mW
9	Storage Temperature	$T_S$	-55	+125	°C

\*Exceeding these values may cause permanent damage. Functional operation under these conditions is not implied.

**Recommended Operating Conditions**

	Parameter	Sym	Min	Typ <sup>‡</sup>	Max	Units	Test Conditions
1	DC Supply Voltages	$V_{CC}$ $V_{EE}$	4.75 -5.25	5.0 -5.0	5.25 -4.75	V V	
2	DC Battery Voltage	$V_{BAT}$	-72	-48	-20	V	
3	DC Ringing Voltage	$V_{DCRI}$	5		110	V	
4	Ringing Input Voltage	RV			2.5	Vrms	Note 1
5	Ringing Output Power	PR		2250		mW	@ 25°C
6	Operating Temperatures	$T_{OP}$	-40	25	85	°C	

<sup>‡</sup> Typical figures are at 25°C with nominal supply voltages and are for design aid only

Note 1: Applies to a sinusoidal input. RV can also be driven with a TTL signal (AC coupled) see MSAN-156.

DC Electrical Characteristics<sup>†</sup>

	Characteristics	Sym	Min	Typ <sup>‡</sup>	Max	Units	Test Conditions
1	Supply Current	$I_{CC}$ $I_{CC}$ $I_{EE}$ $I_{BAT}$ $I_{DCRI}$ $I_{DCRI}$		12 $I_{Loop} + 12$ -12 -3 100 100		mA mA mA mA $\mu$ A mA	Test circuit as Fig 7 On-Hook Off-Hook Note On-Hook On-Hook RC at logic 0 RC at logic 1
2	Power Consumption	PC		40 270	80	mW mW	Power down, On-hook = -48V Idle
3	Constant current feed to line	$I_{Loop}$		24		mA	LCA O/C, $V_{bat} = -48V$ $R_{Loop} = 300\Omega$ , $V_{CC} = 5V$
4	Adjustable loop current range	$I_{Loop}$	14		55	mA	
5	Maximum operating loop resistance	$R_{Loop}$	2000			$\Omega$	$I_{Loop} = 18mA$ , $V_{bat} = -48V$ includes telephone set
6	Tip or Ring to Gnd, Over-Current Protection			100		mA	$V_{bat} = -48V$
7	Low Level Output Voltage High Level Output Voltage	$V_{OL}$ $V_{OH}$			0.4	V V	$I_{OL} = 4mA$ $I_{OH} = 0.4mA$
8	Relay driver current sink capability			20		mA	For SV Relay
9	Low Level Input Voltage High Level Input Voltage Low Level Input Current High Level Input Current	$V_{IL}$ $V_{IH}$ $I_{IL}$ $I_{IH}$		5.0 0.1 0.5	0.8	V V mA mA	
10	Switch Hook detect threshold		4	8.5	13	mA	$V_{bat} = -48V$

<sup>†</sup> Electrical Characteristics are over Recommended Operating Conditions unless otherwise stated.

<sup>‡</sup>Typical figures are at 25°C with nominal supply voltages and are for design aid only.

Note: Figure quoted is the +5V supply current plus loop current which flows between -48V (battery supply) and the +5V supply.



AC Electrical Characteristics<sup>†</sup>

	Characteristics	Sym	Min	Typ <sup>‡</sup>	Max	Units	Test Conditions
1	Ringling drive capability		5			REN	5 REN=1400 Ω @ 20Hz R <sub>LOOP</sub> = 1800Ω V@Load=35V <sub>rms</sub> (@25°C) DCRI=100VDC V <sub>bat</sub> =-48V
2	AC Ringing Amplifier Gain (Note 5) Output Voltage (Note 3) Frequency Range	A <sub>RING</sub> V <sub>RING</sub> F <sub>RING</sub>	16	50 60	68	V <sub>rms</sub> Hz	V <sub>BAT</sub> = -48V DC V <sub>DCRI</sub> = 100V DC RV = 1.2V <sub>rms</sub> sinewave, REN 5
3	Auto Ring Trip & SHK detect time  Ring Trip SHK			200 40		mS mS	Test circuit as Fig 5  RV = 16Hz, RC = 1 RC at logic 0
4	Input Impedance at VR			10		kΩ	
5	Output Impedance at VX				10	Ω	
6	Receive Gain (VR to 2-Wire) Off-Hook  Programmable Range On-Hook (relative to Off-Hook)		-0.2  -12	0  6	0.2  6	dB  dB dB	Test circuit as Fig 7 Input 0.5V at 1kHz  T-R Load > 10kΩ, Output<2.25V @ 1kHz
7	Frequency Response Gain (relative to Gain @ 1kHz)		-0.25	0	0.25	dB	Test circuit as Fig 7 300 - 3400Hz
8	Transmit Gain (2-Wire to VX)  Programmable Range		-0.2  -12	0  6	0.2  6	dB  dB	Test circuit as Fig 6 Input 0.5V @ 1kHz
9	Frequency Response Gain (relative to Gain @ 1kHz)		-0.25	0	0.25	dB	Test circuit as Fig 6 300 - 3400Hz
10	Total Harmonic Distortion at VX and 2-Wire.	THD			1	%	Test circuits as Fig 6&7 Output 0dBm @ 1kHz
11	Overload at VX and 2-Wire.				5	%	Test circuits as Fig 6&7 Output +3dBm @ 1kHz
12	Common Mode Rejection Ratio	CMRR	48			dB	Test circuit as Fig. 9 200 - 3400Hz
13	Idle Channel Noise at VX	Nc		12		dBrnC	Test circuit as Fig. 7 Input 0V
14	Idle Channel Noise at 2-Wire	Nc		12		dBrnC	Test circuit as Fig. 7 Input 0V
15	Power Supply Rejection Ratio at VX and 2-Wire VX 2-Wire	PSRR	25 25			dB dB	Test circuit as Fig. 7 Ripple 0.1V <sub>rms</sub> 1kHz @ V <sub>CC</sub> / V <sub>EE</sub> / V <sub>BAT</sub> / V <sub>DCRI</sub>
16	Transhybrid Loss	THL	18 21			dB	Test circuit as Fig 7 300 - 3400Hz 500 - 2500Hz
17	Return Loss at 2-Wire	RL	18			dB	Test circuit as Fig 8 300 - 3400Hz

AC Electrical Characteristics<sup>†</sup>

	Characteristics	Sym	Min	Typ <sup>‡</sup>	Max	Units	Test Conditions
18	Longitudinal to Metallic Balance		55 48	60 53		dB dB	Test circuit as Fig. 9 200-1000Hz 1000-3400Hz Test circuit as Fig. 10
19	Meter Pulse output level (Note 5)	ESO	1.75	2	2.25	Vrms	ZA= 30K (600R config) T-R AC Load = 200Ω, ESI = 1Vrms
20	Audio settling time after reversal				50	mS	

<sup>†</sup> Electrical Characteristics are over Recommended Operating Conditions unless otherwise stated.

<sup>‡</sup> Typical figures are at 25°C with nominal power supplies unless otherwise stated and are for design aid only.

Test conditions shown in Figures 7-12 are programmed for 600Ω.

Note 1: All of the above test conditions use a test source impedance which matches the device's impedance.

Note 2: dBm is referenced to 600Ω unless otherwise stated.

Note 3: The typical output voltage from the ringing amplifier assumes the output is unloaded.

Note 4: The test shown is for 600R impedance for other impedance use the programming components as shown in Table 1.

Note 5: The gain will change depending on the programming components at ZA. For amplifier gain MSAN156 describes a circuit where the gain can be guaranteed to be 42.

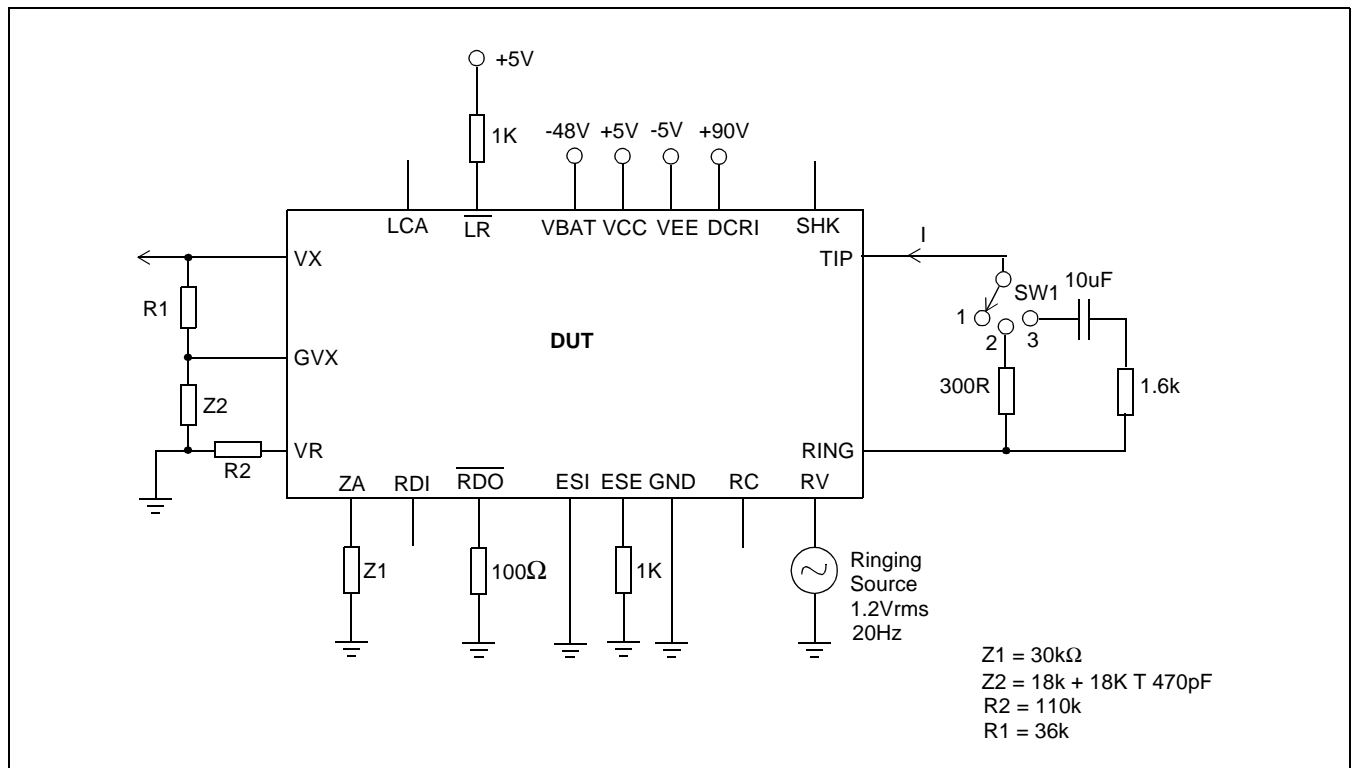

Figure 5 - DC Condition Test

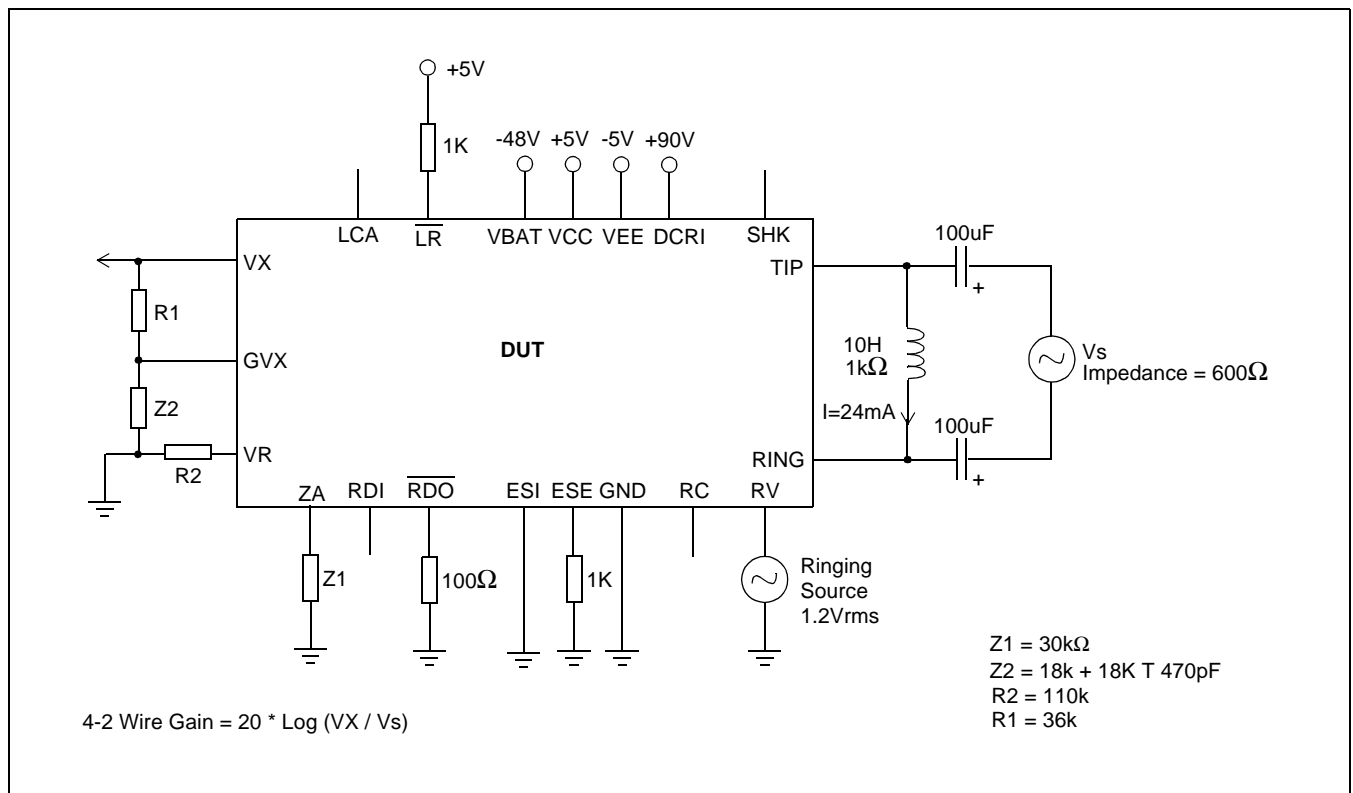

Figure 6 - 2-4 Gain Wire Test Circuit

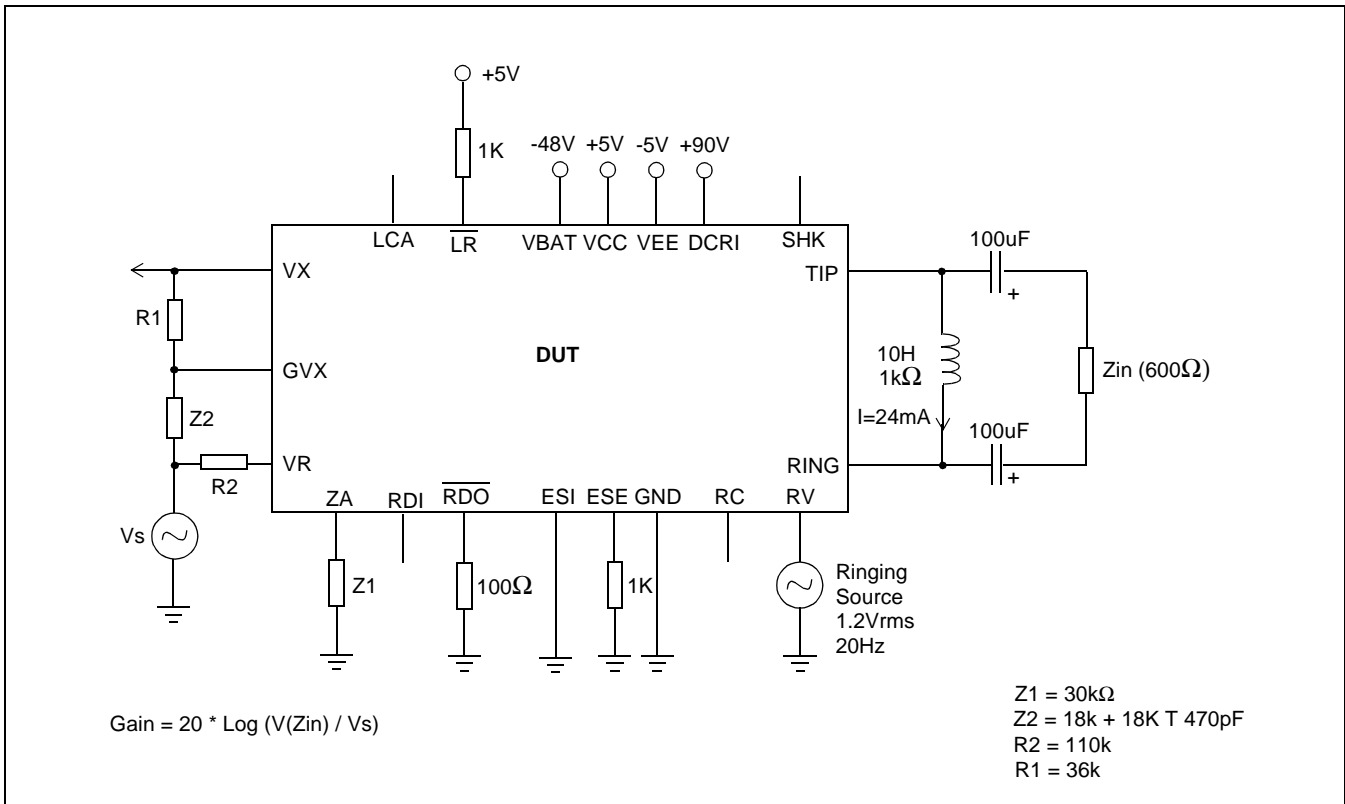

Figure 7 - 4-2 Wire Gain Test Circuit

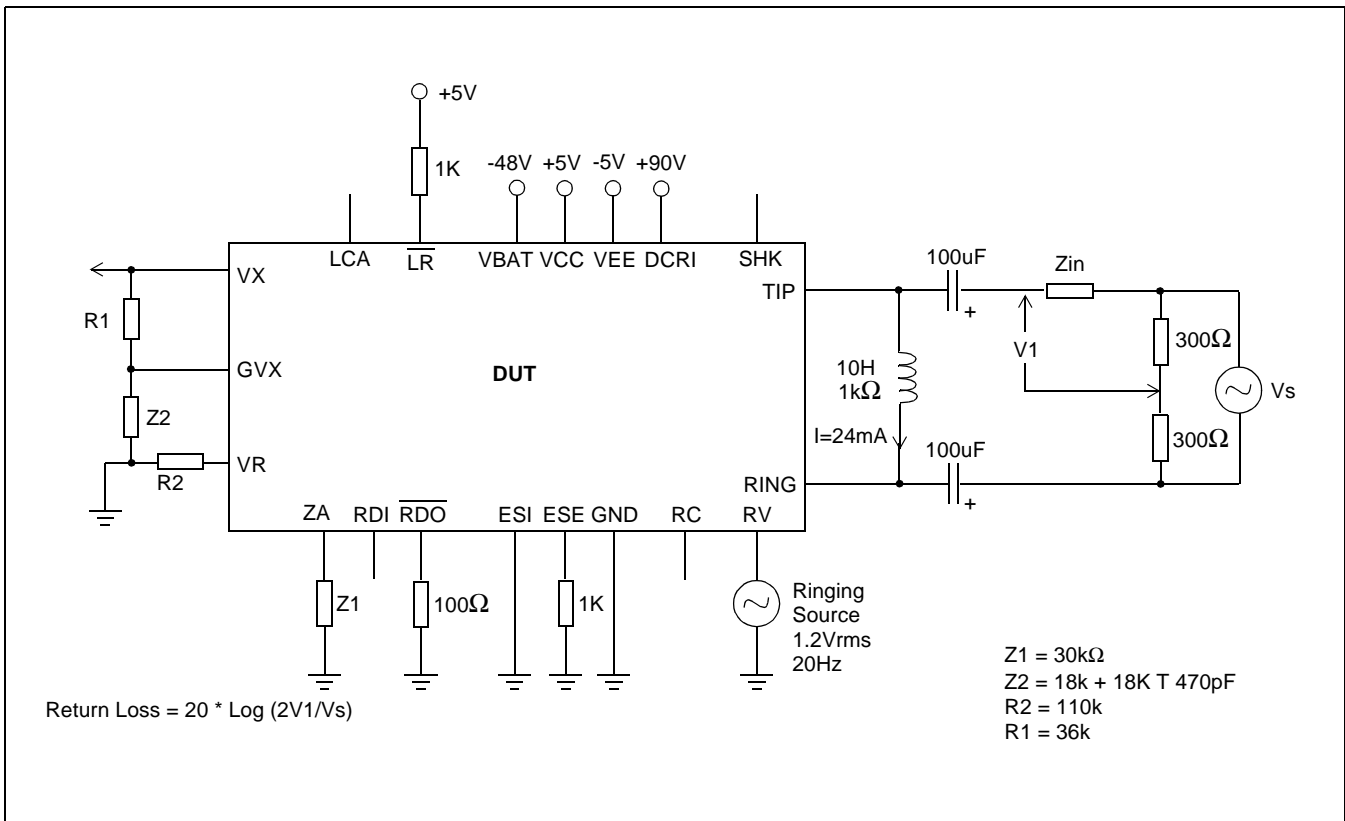

Figure 8 - Return Loss

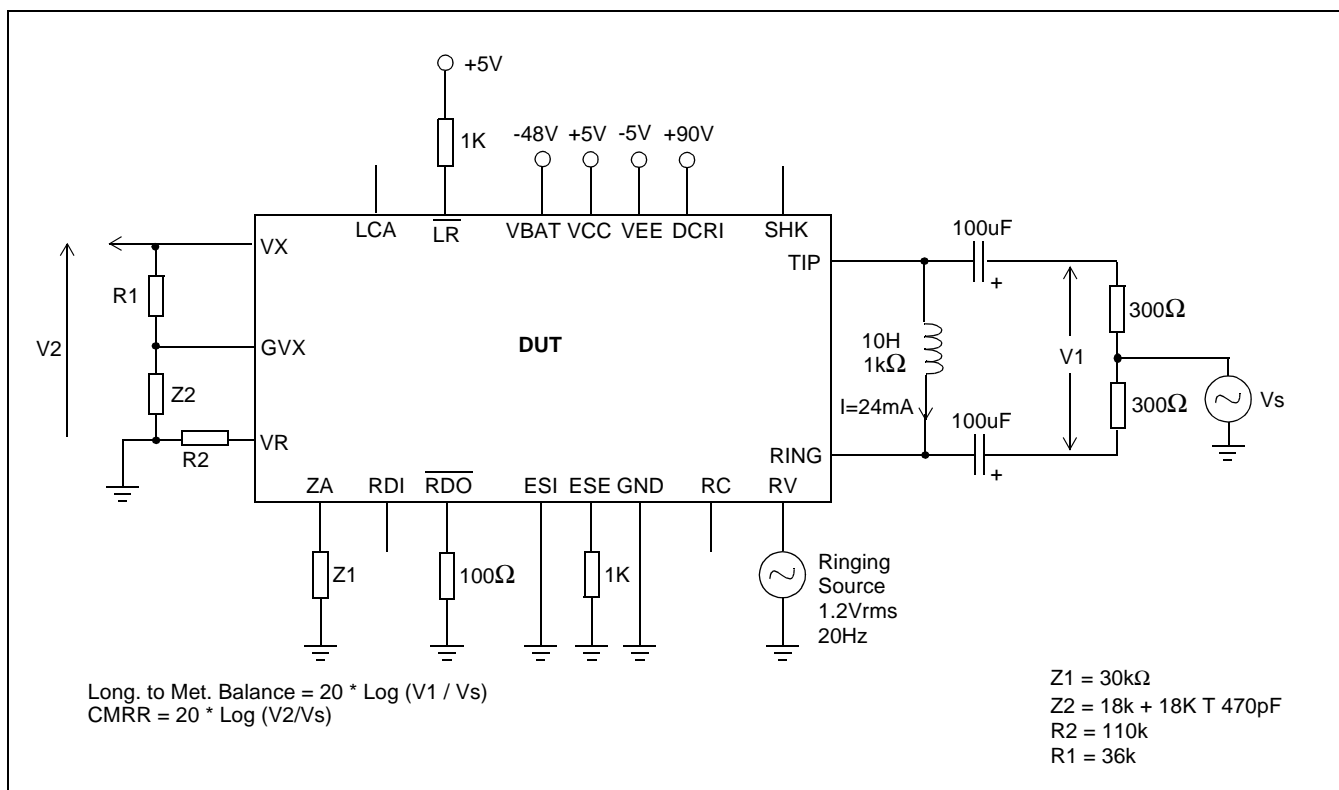

Figure 9 - Longitudinal to Metallic Balance & CMRR Test Circuit

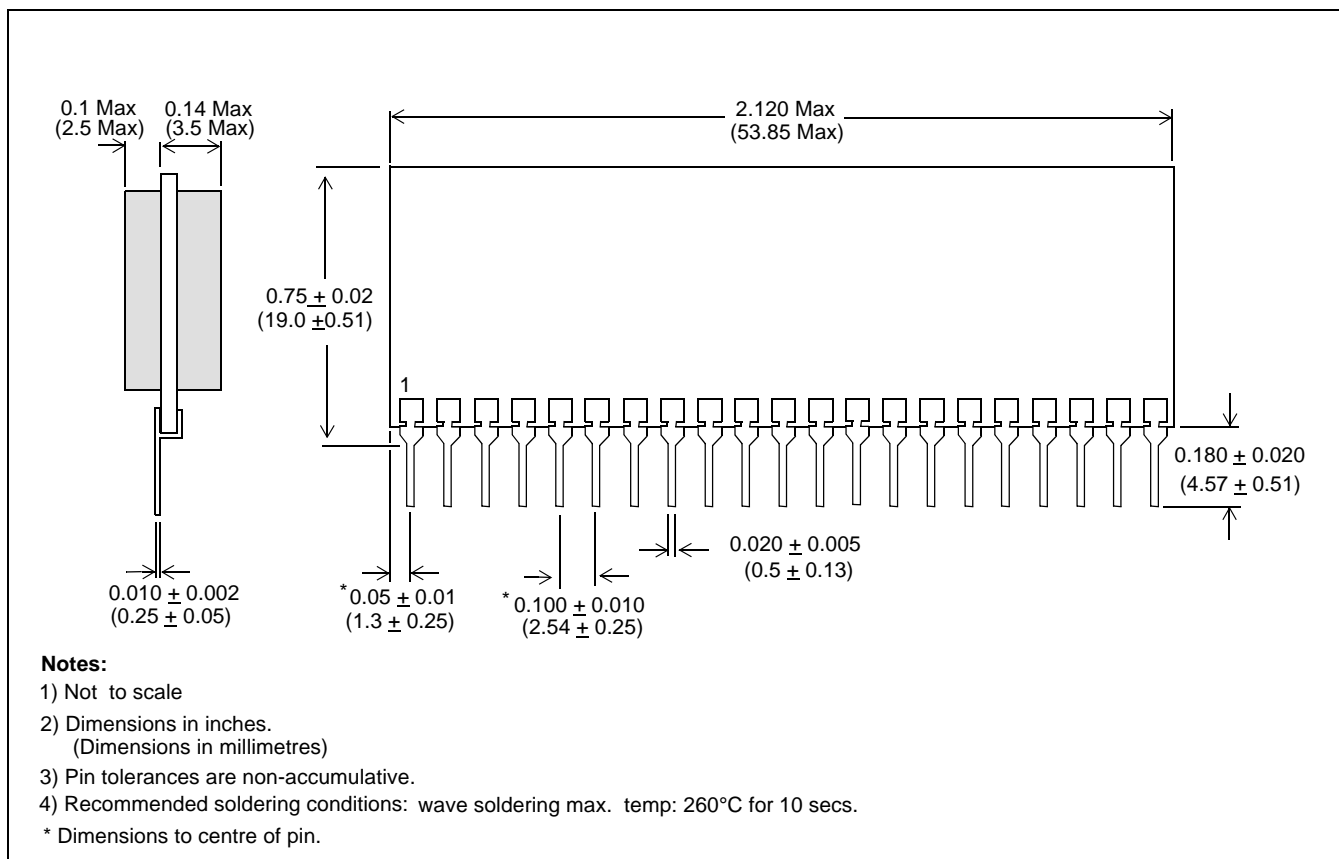

Figure 10 - Mechanical Data for 21 Pin SIL Hybrid



**For more information about all Zarlink products  
visit our Web Site at  
[www.zarlink.com](http://www.zarlink.com)**

Information relating to products and services furnished herein by Zarlink Semiconductor Inc. trading as Zarlink Semiconductor or its subsidiaries (collectively "Zarlink") is believed to be reliable. However, Zarlink assumes no liability for errors that may appear in this publication, or for liability otherwise arising from the application or use of any such information, product or service or for any infringement of patents or other intellectual property rights owned by third parties which may result from such application or use. Neither the supply of such information or purchase of product or service conveys any license, either express or implied, under patents or other intellectual property rights owned by Zarlink or licensed from third parties by Zarlink, whatsoever. Purchasers of products are also hereby notified that the use of product in certain ways or in combination with Zarlink, or non-Zarlink furnished goods or services may infringe patents or other intellectual property rights owned by Zarlink.

This publication is issued to provide information only and (unless agreed by Zarlink in writing) may not be used, applied or reproduced for any purpose nor form part of any order or contract nor to be regarded as a representation relating to the products or services concerned. The products, their specifications, services and other information appearing in this publication are subject to change by Zarlink without notice. No warranty or guarantee express or implied is made regarding the capability, performance or suitability of any product or service. Information concerning possible methods of use is provided as a guide only and does not constitute any guarantee that such methods of use will be satisfactory in a specific piece of equipment. It is the user's responsibility to fully determine the performance and suitability of any equipment using such information and to ensure that any publication or data used is up to date and has not been superseded. Manufacturing does not necessarily include testing of all functions or parameters. These products are not suitable for use in any medical products whose failure to perform may result in significant injury or death to the user. All products and materials are sold and services provided subject to Zarlink's conditions of sale which are available on request.

Purchase of Zarlink's I<sup>2</sup>C components conveys a licence under the Philips I<sup>2</sup>C Patent rights to use these components in an I<sup>2</sup>C System, provided that the system conforms to the I<sup>2</sup>C Standard Specification as defined by Philips.

Zarlink and the Zarlink Semiconductor logo are trademarks of Zarlink Semiconductor Inc.

Copyright 2002, Zarlink Semiconductor Inc. All Rights Reserved.

**TECHNICAL DOCUMENTATION - NOT FOR RESALE**

---