



PL-2305 USB to IEEE 1284 Bridge Controller Product Datasheet

Document Revision 1.1

Document Release: August, 2002

Prolific Technology Inc.

www.datasheet4u.com

www.DataSheet4U.com

PL-2305 USB to IEEE 1284 Bridge Controller

1.0 Features

- Full compliance with the Universal Serial Bus Specification Version 1.1
- Full compliance with the Universal Serial Bus Device Class Definition for Printing Devices Version 1.0
- Full compliance with the IEEE std 1284-1994 – “IEEE Standard Signaling Method for a Bi-directional Parallel Peripheral Interface for Personal Computers”
- On chip transceivers and regulator for USB interface
- Fully automatic high speed bi-directional communication over parallel port
- 512 Bytes unified data buffer dynamically allocated for upstream and downstream data transfer
- Drivers provided for Microsoft Windows 98/NT 5.0

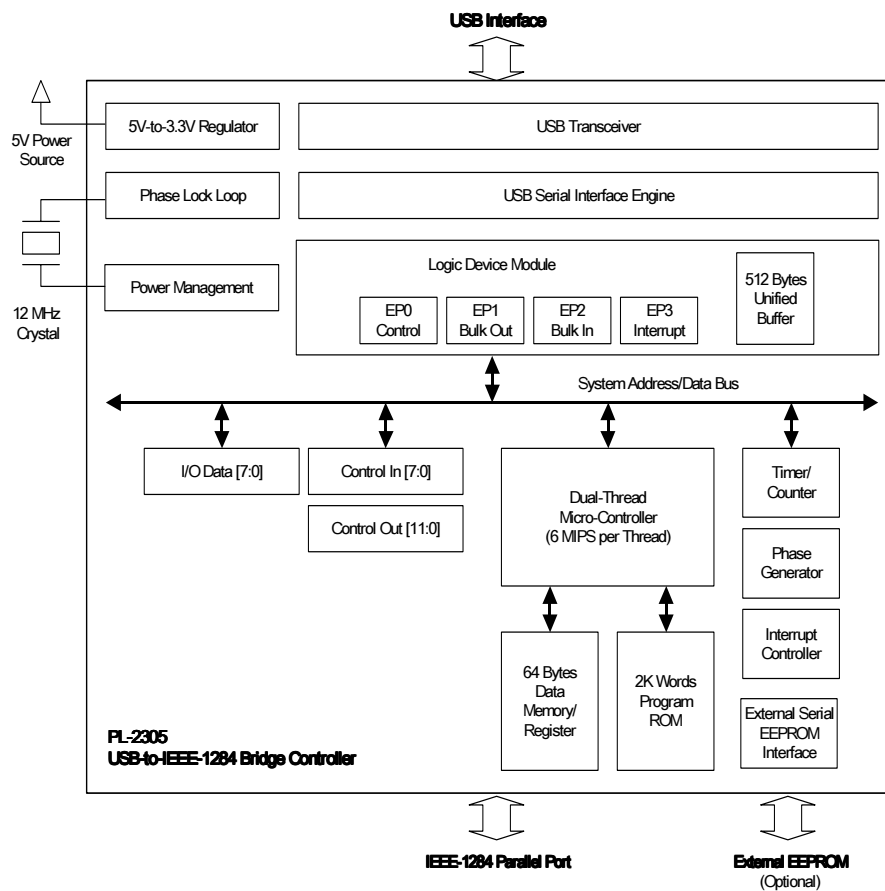

Figure 1. PL-2305 Block Diagram

2.0 Overview

The PL-2305 integrated circuit provides a high-speed bi-directional bridge between the Universal Serial Bus (USB) system and IEEE-1284 parallel port peripheral devices. It is designed to be a flexible, high performance, and low-cost single-chip solution for USB cable as well as USB ready peripheral manufacturers.

Supporting for multi-function devices, such as Printer-FAX-Scanner-Copier all-in-one device, is one of the major design considerations of PL-2305. It provides well-balanced bi-directional data transferring. Retrieving data from external device could be as efficient as transmitting data through this chip.

Ease of programming is another major design consideration of PL-2305. The vendor specific requests of PL-2305 are so defined to reduce the USB bus traffic and hence minimize the host software overhead.

The external serial EEPROM support gives the user of PL-2305 options to customize this chip to show their identity. The user could modify the Vendor ID, Product ID, Language ID, manufacturer string, product string, and serial number strings of the final product. They could also use this EEPROM to store authorization/security codes. For large quantity orders, it is also possible to modify the Maskable ROM (Read Only Memory) of PL-2305 to better represent the final product manufacturer and thus eliminate the need for external EEPROM.

3.0 Pin Description

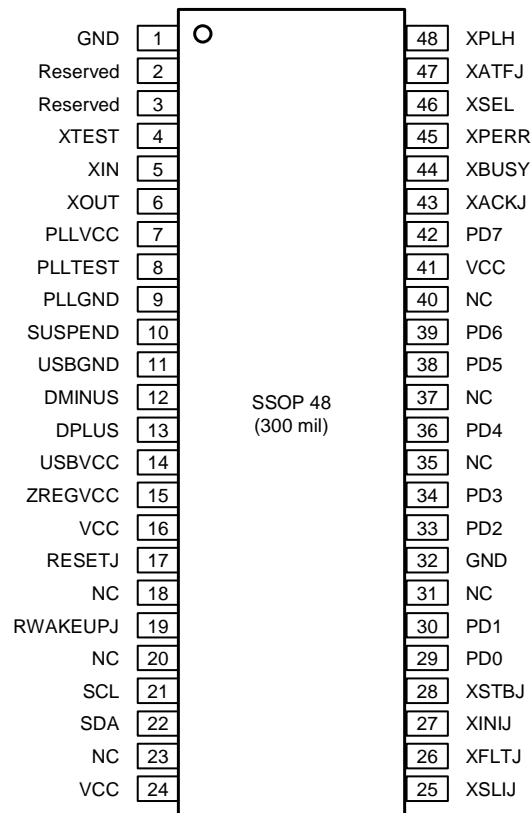

Figure 2. PL-2305 Pin Diagram

Table 1. Pins Description

Pin	Symbol	Type	Description
1	GND	P	Ground.
2	Reserved	–	Reserved, must be tied to ground.
3	Reserved	–	Reserved, must be tied to ground.
4	XTEST	I	Core test pin must be tied to ground for normal operation.
5	XIN	I	Crystal in or CMOS oscillator input.
6	XOUT	O	Crystal out or no connection.
7	PLLVCC	P	5V Analog Power Supply for on-chip PLL.
8	PLLTEST	I	PLL test pin must be tied to ground for normal operation.
9	PLLGND	P	Analog Ground for on-chip PLL.
10	NC	–	No connection.
11	USBGND	P	Ground for on-chip USB transceiver.
12	DMINUS	I/O	USB D- signal.
13	DPLUS	I/O	USB D+ signal.
14	USBVCC	P	3.3V Power Supply for on-chip USB transceiver.
15	ZREGVCC	P	3.3V output from on-chip 5V-to-3.3V regulator.
16	VCC	P	5V Power Supply for on-chip 5V-to-3.3V regulator.

Pin	Symbol	Type	Description
17	RESETJ	I	Optional external Power-On-Reset signal.
18	NC	–	No connection.
19	RWAKEUPJ	I	USB Remote Wake enable, tied to VCC if no remote wake up control is available.*
20	NC	–	No connection.
21	SCL	I/O	Clock for external Serial EEPROM.
22	SDA	I/O	Data/Address for external Serial EEPROM.
23	NC	–	No connection.
24	VCC	P	5V Power Supply.
25	XSLIJ	O	nSelectIn signal for Parallel port.
26	XFLTJ	I	nFault signal for Parallel port.
27	XINIJ	O	nInIt signal for Parallel port.
28	XSTBJ	O	nStrobe signal for Parallel port.
29	PD0	I/O	Data bit 0 for Parallel port.
30	PD1	I/O	Data bit 1 for Parallel port.
31	NC	–	No connection.
32	GND	P	Ground.
33	PD2	I/O	Data bit 2 for Parallel port.
34	PD3	I/O	Data bit 3 for Parallel port.
35	NC	–	No connection.
36	PD4	I/O	Data bit 4 for Parallel port.
37	NC	–	No connection.
38	PD5	I/O	Data bit 5 for Parallel port.
39	PD6	I/O	Data bit 6 for Parallel port.
40	NC	–	No connection.
41	VCC	P	5V Power Supply.
42	PD7	I/O	Data bit 7 for Parallel port.
43	XACKJ	I	nAck signal for Parallel port.
44	XBUSY	I	Busy signal for Parallel port.
45	XPERR	I	PError signal for Parallel port.
46	XSEL	I	Select signal for Parallel port.
47	XATFJ	O	nAutoFd signal for Parallel port.
48	XPLH	I	PLH signal for Parallel port.

Type: *I* – Input signal *O* – Output signal *I/O* – Bi-directional signal *P* – Power/Ground

4.0 USB Port Descriptor

PL-2305 supports the following standard USB descriptors:

- Device – PL-2305 has one device descriptor.
- Configuration – PL-2305 has one default configuration descriptor that supports one interface.
- Interface – PL-2305 has a single data interface with three possible alternates.
- Endpoint – PL-2305 supports the following endpoints:
 - ❖ Bulk Out endpoint for PDL/PCP data.
 - ❖ Optional Bulk In endpoint for status and other return/upstream information.
 - ❖ Optional Interrupt endpoint for asynchronous event handling.
- String

4.1 Device Descriptor

Offset	Field	Size	Value	Description
0	bLength	Byte	12h	Size of this descriptor in bytes.
1	bDescriptorType	Byte	01h	DEVICE descriptor type.
2	bcdUSB	Word	0100h	USB Specification version 1.0
4	bDeviceClass	Byte	00h	Interface Specific.
5	bDeviceSubclass	Byte	00h	Interface Specific.
6	bDeviceProtocol	Byte	00h	Interface Specific.
7	wMaxPacketSize0	Byte	08h	Maximum packet size for endpoint 0 is 8.
8	idVendor	Word	067Bh	Vendor ID for Prolific Technologies. ⁽¹⁾
10	idProduct	Word	2303h	Product ID for PL-2305. ⁽¹⁾
12	bcdDevice	Word	0100h	Device Release 1.0. ⁽¹⁾
14	iManufacturer	Byte	01h	String index 1 describes manufacturer. ⁽²⁾
15	iProduct	Byte	02h	String index 2 describes product. ⁽³⁾
16	iSerialNumber	Byte	03h	String index 3 describes serial number. ⁽⁴⁾
17	bNumConfigurations	Byte	01h	One possible configurations.

Note:

- (1) – These default values shown here could be modified by external EEPROM;
- (2) – The default string is “Prolific Technology Inc.” in UNICODE format and could be replaced by the contents of external EEPROM;
- (3) – The default string is “IEEE-1284 Controller” in UNICODE format and could be replaced by the contents of external EEPROM;
- (4) – The default string is “0” in UNICODE format and could be replaced by the contents of external EEPROM.

4.2 Configuration Descriptor

Offset	Field	Size	Value	Description
0	bLength	Byte	09h	Size of this descriptor in bytes.
1	bDescriptorType	Byte	02h	CONFIGURATION descriptor type.
2	bTotalLength	Word	004Eh	78 bytes of all INTERFACE & ENDPOINT.
4	bNumInterfaces	Byte	01h	The PL-2305 has one interface.
5	bConfigurationValue	Byte	01h	Value to write to the Device Configuration Register (DCR) to select this configuration.
6	iConfiguration	Byte	00h	No string description for this.
7	bmAttributes	Byte	A0h	Configuration characteristics: Bus Powered & Remote Wakeup.
8	MaxPower	Byte	32h	Maximum power consumption is 100 mA.

4.3 Interface Descriptors

The PL-2305 supports a single data interface with three alternate settings. Alternate 0 and 1 are “USB Device Class Definition for Printing Devices” compliant. Alternate 3 is vendor specific to support more complicate IEEE-1284 device operations.

4.3.1 Interface 0, Alternate Setting 0 (I0:A0)

This is a Unidirectional Interface, which supports sending the data to the printer via a Bulk Out endpoint. Status data that is compatible with Centronic parallel port is retrieved via the Class-Specific command GET_PORT_STATUS over the default control pipe.

Interface Descriptor, I0:A0

Offset	Field	Size	Value	Description
0	bLength	Byte	09h	Size of this descriptor in bytes.
1	bDescriptorType	Byte	04h	INTERFACE descriptor type.
2	bInterfaceNumber	Byte	00h	Interface 0.
3	bAlternateSetting	Byte	00h	Alternate 0.
4	bNumEndpoints	Byte	01h	Supports endpoint 0 and 1.
5	bInterfaceClass	Byte	07h	Printer Class.
6	iInterfaceSubClass	Byte	01h	Printer Subclass.
7	bInterfaceProtocol	Byte	01h	Unidirectional Interface.
8	iInterface	Byte	00h	No String descriptor for this interface.

Bulk Out Endpoint Descriptor, I0:A0:E1

Offset	Field	Size	Value	Description
0	bLength	Byte	07h	Size of this descriptor in bytes.
1	bDescriptorType	Byte	05h	ENDPOINT descriptor type.
2	bEndpointAddress	Byte	01h	Out Endpoint 1.
3	bmAttributes	Byte	02h	BULK Endpoint
4	wMaxPacketSize	Word	0040h	Maximum packet size is 64.
6	bInterval	Byte	00h	N/A

4.3.2 Interface 0, Alternate Setting 1 (I0:A1)

This is a Bi-directional Interface, which supports sending the data to the printer via a Bulk Out endpoint, and receiving status and other information from the printer via a Bulk In endpoint. Status data that is compatible with Centronic Parallel port is also available via the GET_PORT_STATUS class-specific request.

Interface Descriptor, I0:A1

Offset	Field	Size	Value	Description
0	bLength	Byte	09h	Size of this descriptor in bytes.
1	bDescriptorType	Byte	04h	INTERFACE descriptor type.
2	bInterfaceNumber	Byte	00h	Interface 0.
3	bAlternateSetting	Byte	01h	Alternate 1.
4	bNumEndpoints	Byte	02h	Supports endpoint 0, 1, and 2.
5	bInterfaceClass	Byte	07h	Printer Class.
6	iInterfaceSubClass	Byte	01h	Printer Subclass.
7	bInterfaceProtocol	Byte	02h	Bi-directional Interface.
8	iInterface	Byte	00h	No String descriptor for this interface.

Bulk Out Endpoint Descriptor, I0:A1:E1

Offset	Field	Size	Value	Description
0	bLength	Byte	07h	Size of this descriptor in bytes.
1	bDescriptorType	Byte	05h	ENDPOINT descriptor type.
2	bEndpointAddress	Byte	01h	Out Endpoint 1.
3	bmAttributes	Byte	02h	BULK Endpoint
4	wMaxPacketSize	Word	0040h	Maximum packet size is 64.
6	bInterval	Byte	00h	N/A

Bulk In Endpoint Descriptor, I0:A1:E2

Offset	Field	Size	Value	Description
0	bLength	Byte	07h	Size of this descriptor in bytes.
1	bDescriptorType	Byte	05h	ENDPOINT descriptor type.
2	bEndpointAddress	Byte	82h	In Endpoint 2.
3	bmAttributes	Byte	02h	BULK Endpoint
4	wMaxPacketSize	Word	0040h	Maximum packet size is 64.
6	bInterval	Byte	00h	N/A

4.3.3 Interface 0, Alternate Setting 2 (I0:A2)
Interface Descriptor, I0:A2

Offset	Field	Size	Value	Description
0	bLength	Byte	09h	Size of this descriptor in bytes.
1	bDescriptorType	Byte	04h	INTERFACE descriptor type.
2	bInterfaceNumber	Byte	00h	Interface 0.
3	bAlternateSetting	Byte	02h	Alternate 2.
4	bNumEndpoints	Byte	03h	Supports endpoint 0, 1, 2, and 3.
5	bInterfaceClass	Byte	FFh	Vendor specific.
6	iInterfaceSubClass	Byte	00h	–
7	bInterfaceProtocol	Byte	FFh	Vendor specific.
8	iInterface	Byte	00h	No String descriptor for this interface.

Bulk Out Endpoint Descriptor, I0:A2:E1

Offset	Field	Size	Value	Description
0	bLength	Byte	07h	Size of this descriptor in bytes.
1	bDescriptorType	Byte	05h	ENDPOINT descriptor type.
2	bEndpointAddress	Byte	01h	Out Endpoint 1.
3	bmAttributes	Byte	02h	BULK Endpoint
4	wMaxPacketSize	Word	0040h	Maximum packet size is 64.
6	bInterval	Byte	00h	N/A

Bulk In Endpoint Descriptor, I0:A2:E2

Offset	Field	Size	Value	Description
0	bLength	Byte	07h	Size of this descriptor in bytes.
1	bDescriptorType	Byte	05h	ENDPOINT descriptor type.
2	bEndpointAddress	Byte	82h	In Endpoint 2.
3	bmAttributes	Byte	02h	BULK Endpoint
4	wMaxPacketSize	Word	0040h	Maximum packet size is 64.
6	bInterval	Byte	00h	N/A

Bulk In Endpoint Descriptor, I0:A2:E3

Offset	Field	Size	Value	Description
0	bLength	Byte	07h	Size of this descriptor in bytes.
1	bDescriptorType	Byte	05h	ENDPOINT descriptor type.
2	bEndpointAddress	Byte	83h	In Endpoint 3.
3	bmAttributes	Byte	03h	INTERRUPT Endpoint
4	wMaxPacketSize	Word	0004h	Maximum packet size is 4.
6	bInterval	Byte	01h	This pipe should be pulled every frame.

5.0 Device Control Requests

PL-2305 supports three types of requests:

- Standard USB device requests, which perform general functions for supporting the bus and bus related functions.
- Printer class specific requests, which cause the device to transfer command/data to or from the device.
- Vendor specific requests, which gives the host thorough controls over the parallel port and access to the full capabilities of IEEE-1284 specification.

5.1 Standard Device Control Requests

- SET_FEATURE/CLEAR_FEATURE: Supports DEVICE_REMOTE_WAKEUP and ENDPOINT_STALL for all endpoints. Mismatched bmRequestType or endpoint number will cause STALL.
- SET_CONFIGURATION/GET_CONFIGURATION
- GET_INTERFACE/SET_INTERFACE
- SET_ADDRESS
- GET_STATUS
- GET_DESCRIPTOR

Note: SET_DESCRIPTOR and SYNCH_FRAME are not supported by the PL-2305.

5.2 Printer Class-Specific Device Requests

Label	bmRequestType	bRequest	wValue	wIndex	wLength	Data
GET_DEVICE_ID	10100001b	0	0	0	Max. Length	1284 Device ID String
GET_PORT_STATUS	10100001b	1	0	0	1	BYTE
SOFT_RESET	00100011b	2	0	0	0	None

5.2.1 GET_DEVICE_ID Request (0)

This printer class-specific request returns a Device ID string that is compatible with IEEE-1284. See IEEE-1284 Specification for syntax and formatting information.

The returned data of this request is a sequence of byte retrieved from the peripheral directly. The first two bytes are the length of the sequence. The first byte is the most significant byte. (Length value 0x0000, 0x0001, and 0x0002 are reserved.) The following sequence shows a simple Device ID string: {0x00, 0x0F, "MFG: Prolific"}. The total length of this string is 15, including the two length bytes. In case that the peripheral does not support the Device ID request, the PL-2305 would return a zero-length data packet to the host.

5.2.2 GET_PORT_STATUS Request (1)

This class-specific request returns the current status of the status register of the Centronic parallel port. The following table defines the data returned. USB Data transfers use ACK and NAK replaces Centronic Busy and Ack status.

Symbol	Bit	Description	Note
–	7:6	Reserved, must be zero.	
Paper Empty	5	0 – Paper not empty; 1 – Paper empty.	
Select	4	0 – Not selected; 1 – Selected.	
Not Error	3	0 –Error; 1 –No Error.	
–	2:0	Reserved, must be zero.	

5.2.3 SOFT_RESET Request (2)

This class-specific request flushes all buffers and resets the Bulk-Out and Bulk-In pipes to their default states. This reset does not changes the USB addressing and USB configuration.

5.3 Vendor-Specific Device Requests

The PL-2305 defines a set of vendor-specific requests to provide more versatile control over the IEEE-1284 parallel port for the system programmer. The standard and class-specific requests should be suffice to support most printer type peripherals. However, to gain most performance out of the parallel port for some multi-functional type of devices or to handle some not so compatible parallel port implementations, the following vendor-specific requests might become handy.

6.0 Data Format Defined in EEPROM

The EEPROM is organized as following:

Address	Content	Note
1:0	Check Word (Predefined constant)	
3:2	Vendor ID (idVendor field of Device Descriptor)	
5:4	Product ID (idProduct field of Device Descriptor)	
7:6	Device Release Number (bcdDevice field of Device Descriptor)	
8	Configuration Attribute	
9	Configuration MaxPower	
255:8	String Descriptor Table	

The String Descriptor table is a linked data structure that holds all string descriptors recognized by this chip in the order of its index. The first entry, String 0, represents the Language ID, as defined by the USB specification. The second entry, String 1, is the Manufacturer Descriptor, as defined by the Device Descriptor of PL-2305. The third and fourth entries, String 2 and 3, are the Product Descriptor and Serial Number, respective, also defined by the Device Descriptor. The user has the option to define String 4, 5, and 6 for their own private use. Each of the these String Descriptor Entries is of the following data structure:

Offset	Field	Size	Value	Note
0	bLength	1	Length of the string plus 2, i.e. (N + 2).	
1	bDescriptorType	1	03h – STRING Descriptor type.	
2	bString	N	UNICODE encoded string.	

The last entry of this table must have bLength of 0 to indicate the end of this table. If the host tries to access to the string descriptor beyond the last one, a zero-length data will be returned. The following table shows one example of valid EEPROM contents.

Offset	Content	Note
0:1	Check Word	Constant
2:3	Vendor ID – 0x067B	
4:5	Product ID – 0x2305	
6:7	Device Release Number – 0x0100	
8	Attributes - 0xA0	D7 Bus Powered D6 Self Powered D5 Remote Wakeup D4:D0 reserved For devices that use power form the bus and a local source sets both D7 and D6.
9	MaxPower – 0x32	Expressed in 2mA units (i.e.,50=100mA)

Offset	Content	Note
15:10	must be "0x00"	Reserved for future use
16	0x04	String Index 0
17	0x03	
19:18	0x0409	Language ID for English (United States).
20	0x32	String Index 1
21	0x03	
69:22	'P', 0x00, 'r', 0x00, 'o', 0x00, 'l', 0x00, 'i', 0x00, 'f', 0x00, 'i', 0x00, 'c', 0x00, ' ', 0x00, 'T', 0x00, 'e', 0x00, 'c', 0x00, 'h', 0x00, 'n', 0x00, 'o', 0x00, 'l', 0x00, 'o', 0x00, 'g', 0x00, 'y', 0x00, ' ', 0x00, 'l', 0x00, 'n', 0x00, 'c', 0x00, ' ', 0x00	"Prolific Technology Inc." – manufacturer description. 0x00 is padded for UNICODE.
70	0x2A	String Index 2
71	0x03	
111:72	'I', 0x00, 'E', 0x00, 'E', 0x00, 'E', 0x00, '-', 0x00, '1', 0x00, '2', 0x00, '8', 0x00, '4', 0x00, ' ', 0x00, 'C', 0x00, 'o', 0x00, 'n', 0x00, 't', 0x00, 'r', 0x00, 'o', 0x00, 'l', 0x00, 'l', 0x00, 'e', 0x00, 'r', 0x00	"IEEE-1284 Controller" – device description. 0x00 is padded for UNICODE.
112	0x0A	String Index 3
113	0x03	
121:114	'0', 0x00, '1', 0x00, '2', 0x00, '3', 0x00	"3210" – serial number,
122	0x00	End of String Descriptor Table.

The user could also define other strings, 4 to 6, to hold useful information for the drivers and/or applications, such as software authorization codes, public key for password encryption, symbolic names, just to name a few. However, the total length of this table must not exceed 256 bytes, the supported maximum size of external EEPROM.

7. DC Characteristics

7.1 Absolute Maximum Ratings

Symbol	Parameter	Rating	Units
V _{cc}	Power Supply	-0.3 to 6.0	V
V _{in}	Input Voltage	-0.3 to V _{cc} +0.3	V
V _{out}	Output Voltage	-0.3 to V _{cc} +0.3	V
T _{stg}	Storage Temperature	-55 to 150	C

7.2 Recommended Operation Conditions

Symbol	Parameter	Min	Typ	Max	Units
V _{cc}	Commercial Power Supply	4.75	5.0	5.25	V
V _{in}	Input Voltage	0		V _{cc}	V
T _j	Commercial Junction Operation Temperature	0	25	115	C

7.3 General DC Characteristics

Symbol	Parameter	Conditions	Min	Typ	Max	Units
I _{il}	Input leakage current	No pull-up or pull-down	-1		1	uA
I _{oz}	Tri-state leakage current		-10		10	uA
C _{in}	Input capacitance			3		pF
C _{out}	Output capacitance			3		pF
C _{bid3}	Bi-directional buffer capacitance			3		pF

Note: The Capacitance listed above does not include PAD capacitance and package capacitance.

7.4 DC Electrical Characteristics for 5V Operation

Symbol	Parameter	Conditions	Min	Typ	Max	Units
Vil	Input low voltage	CMOS			0.3*Vcc	V
Vih	Input high voltage	CMOS	0.7*Vcc			V
Vt-	Schmitt trigger negative going threshold voltage	CMOS		1.84		V
Vt+	Schmitt trigger positive going threshold voltage	CMOS		3.22		V
Vol	Output low voltage	Iol=12mA and Pin=PD7~PD0, XSLIJ, XINIJ, XSTBJ, or XATFJ			0.4	V
Voh	Output high voltage	Ioh=12mA and Pin=PD7~PD0	3.5			V
Ri	Input pull-up/pull-down resistance	Vil=0 V or Vih = Vcc and Pin=PD7~PD0		50		KΩ

7.5 USB Transceiver Characteristics

Parameter	Symbol	Min	Typ	Max	Unit
Rise and Fall Times: (10%—90%)	TR	4	8	15	ns
(90%—10%)	TF	4	8	15	ns
Cross Point	Vcr	1.3	--	2.0	V
Output Impedance	RD	23	28	33	ohm
High Level Output	VoH	2.8	--	--	V
Low Level Output	VoL	--	--	0.7	V

Note: CL = 50pf

8.0 Outline Diagram

48-Pin SSOP

Symbol	Dimension in inch			Dimension in mm		
	Min	Nom	Max	Min	Nom	Max
A	0.095	0.102	0.110	2.41	2.59	2.79
A1	0.008	0.012	0.016	0.20	0.30	0.41
A2	0.085	0.090	0.095	2.16	2.29	2.41
b	0.008	0.010	0.013	0.20	0.25	0.33
c	0.006	0.008	0.010	0.15	0.20	0.25
D	--	0.625	0.637	--	15.88	16.18
E	0.291	0.295	0.299	7.39	7.49	7.59
e	--	0.025	--	--	0.64	--
HE	0.395	0.408	0.420	10.03	10.36	10.67
L	0.025	0.030	0.040	0.64	0.76	1.02
L1	0.049	0.057	0.063	1.24	1.45	1.60
S	--	--	0.035	--	--	0.69

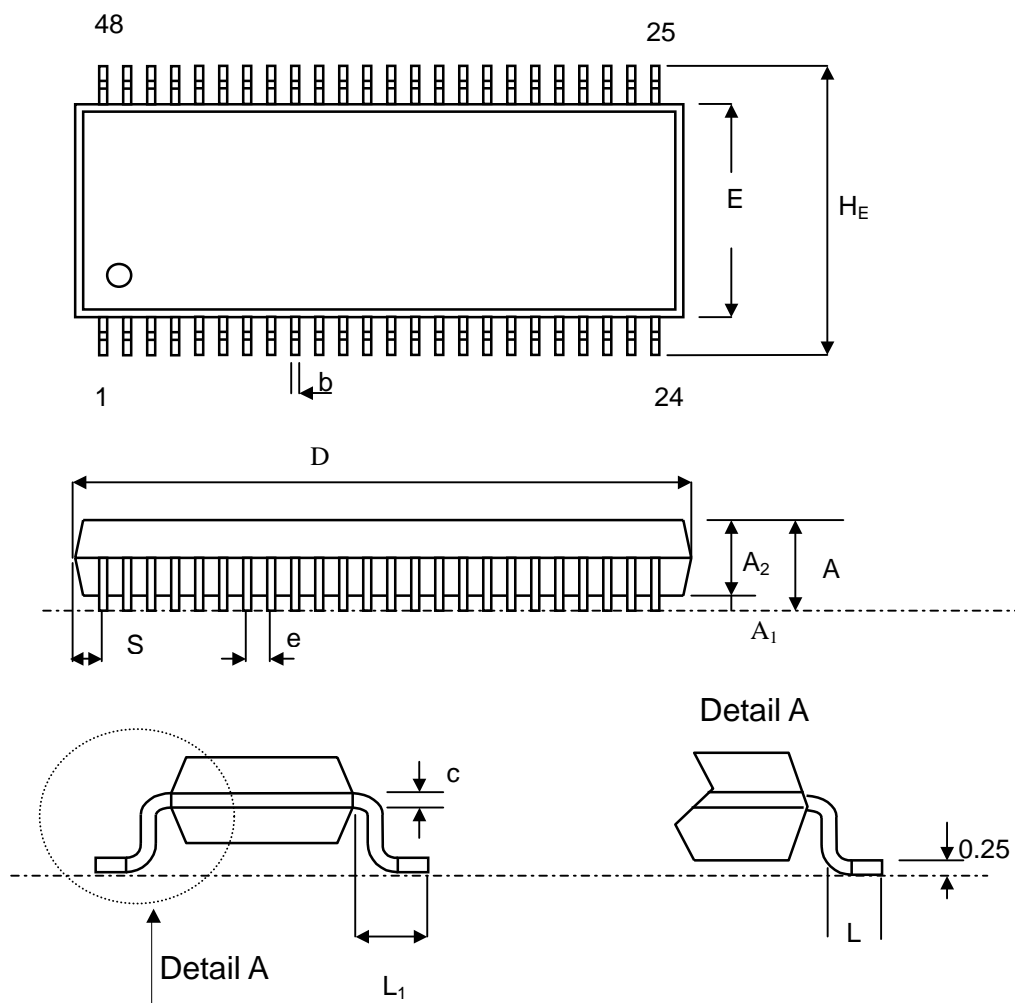

Figure 3. PL-2305 Outline Diagram

9.0 Chip Revision History

Revision E2:

- Add additional mode selection options defined in MSM register to cooperate with diverse printers.

Revision F:

- Add additional option to enable fast upstream data transfer in ECP mode.
- Modified the EPP mode related requests and the control settings of upstream flow.
- Definition of pin 10 and pin 19 are different also.
- The iSerialNumber field in device descriptor is changed to 00h.

Revision H:

- Newly added request GET_CHIP_VERSION
- Reserved range of EEPROM is expended from 8 to 16 bytes to host more user-defined variables.
- SIE circuit modified.