

Service
Service
Service

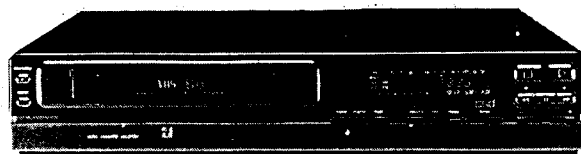

44115A

Service Manual

VHS

PAL

VR6448/67S is a video cassette recorder with a TV-reception part and electronic timer, suitable for recording and playing back TV signals, which meet the CCIR-PAL B.G. standard.

The signals are recorded on tape according to the VHS standard.

CONTENTS

Specification	2
Disassembly and reassembly	3
Trouble shooting guide	8
Mechanical repairs and adjustments	12
Adjustment of electrical circuits	28
Overall wiring diagram	37
Schematic diagram, printed wiring boards etc.	38
Parts list	55

Safety regulations require that the set be restored to its original condition and that parts which are identical with those specified be used.

Documentation Technique Service Dokumentation Documentazione di Servizio Huolto-Ohje Manual de Servicio Manual de Servicio

Subject to modification
4822 726 14526

Printed in The Netherlands
© Copyright reserved

Published by
Service Consumer Electronics

CS 17 216

VR6448/67S SPECIFICATIONS

Format: VHS PAL standard
Video recording system: Two rotary head helical scan system
Video signal: PAL colour and B/W signals, 625 lines
Recording/playing time: 4 hours max. with E-240 tape
Tape width: 12.7 mm
Tape speed: 23.39 mm/sec.
Antenna: 75 ohm unbalanced
Receiving channel: VHF Channel 2-12, UHF Channel 21-69
RF converter output signal: VHF Channel 3 or 4 (Switchable). Preset to 3 Channel
Power requirement: AC 220V, 50 Hz
Power consumption: Approx. 25W (with anti-dew heater)
Operating temperature: 5°C to 40°C
Storage temperature: -20°C to 55°C
Weight: 5.9 kg
Dimensions: 430 mm (W) x 348 mm (D) x 82 mm (H)

VIDEO
Input: 1.0 Vp-p, 75 ohm
Output: 1.0 Vp-p, 75 ohm
AUDIO: 0 dB = 0.775 Vrms
Input: Line: -8 dB, more than 50k ohm
Output: Line: -5 dB, less than 1k ohm

Accessories included: Antenna 75 ohm coaxial connector cable (plug provided)
Operation Manual
Infrared remote control

As part of our policy of continuous improvement, we reserve the right to alter design and specifications without notice.

The antenna must correspond to the new standard DIN 45325 (IEC 169-2) for combined UHF/VHF antenna with 75 ohm connector.

DISASSEMBLY AND REASSEMBLY

1. Remove the four upper cabinet fastening screws ①.
2. Remove the six bottom panel fastening screws ②.
3. Remove the one front panel fastening screw ③.
4. Release the three clips ④ and remove the front panel.
5. Remove the two antenna terminal cover fastening screws ⑤.
6. Remove the two main PWB fastening screws ⑥.
7. Remove the two head amp PWB fastening screws ⑦.
8. Remove the three power unit fastening screws ⑧.
9. Remove the four mechanism chassis fastening screws ⑨.
10. Release the timer PWB ⑩ fastening clips.
11. Release the operation PWB ⑪ fastening clips.

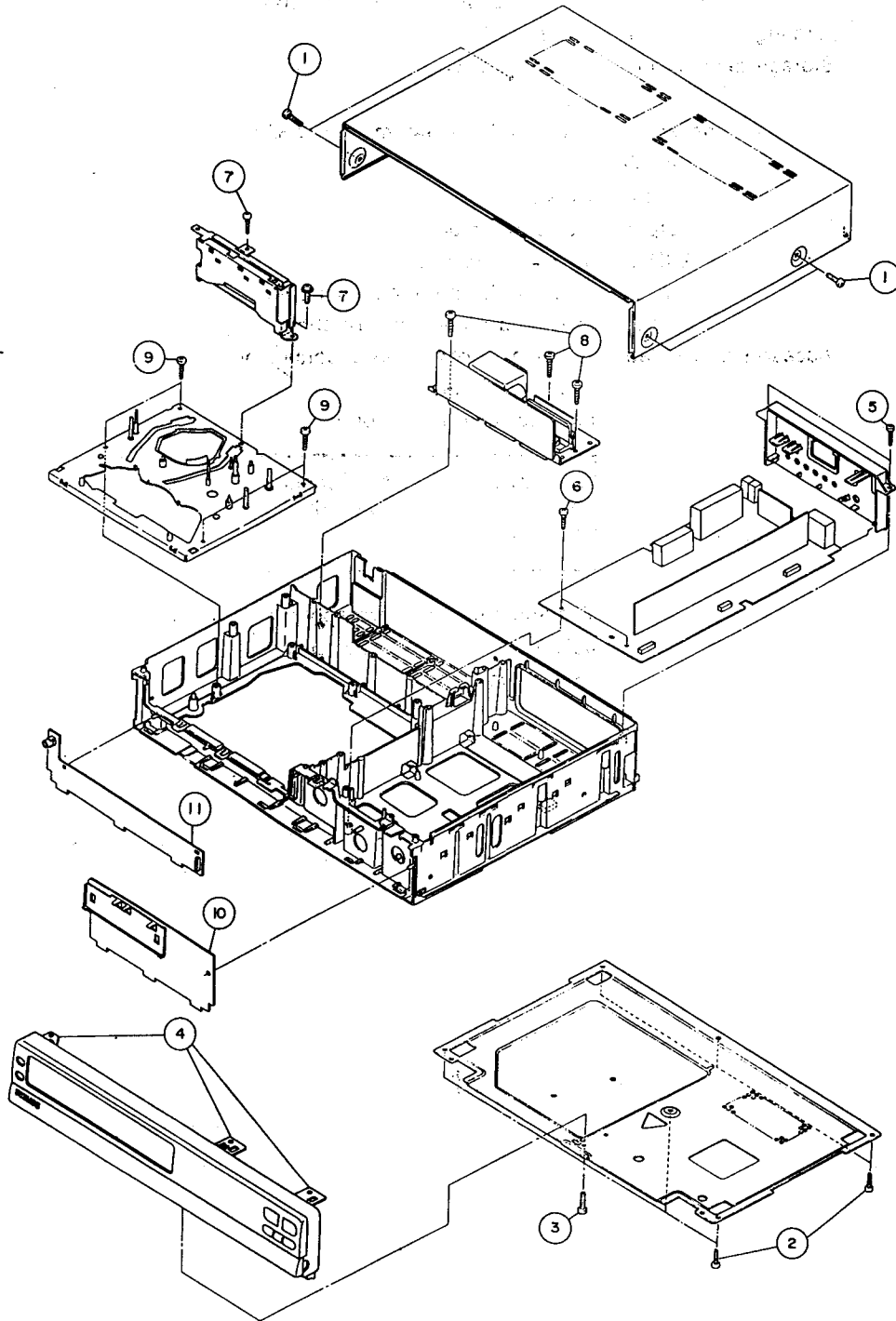

LOCATION OF MECHANICAL PARTS

• TOP VIEW

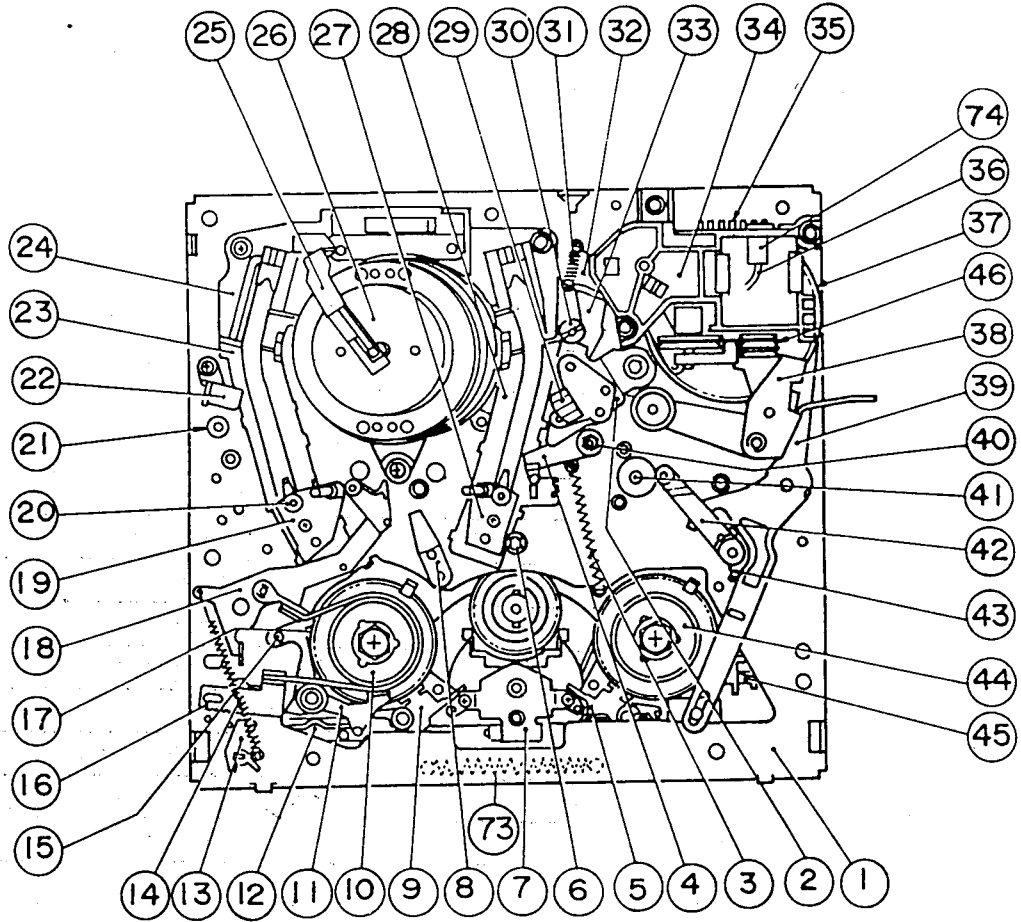

• BOTTOM VIEW

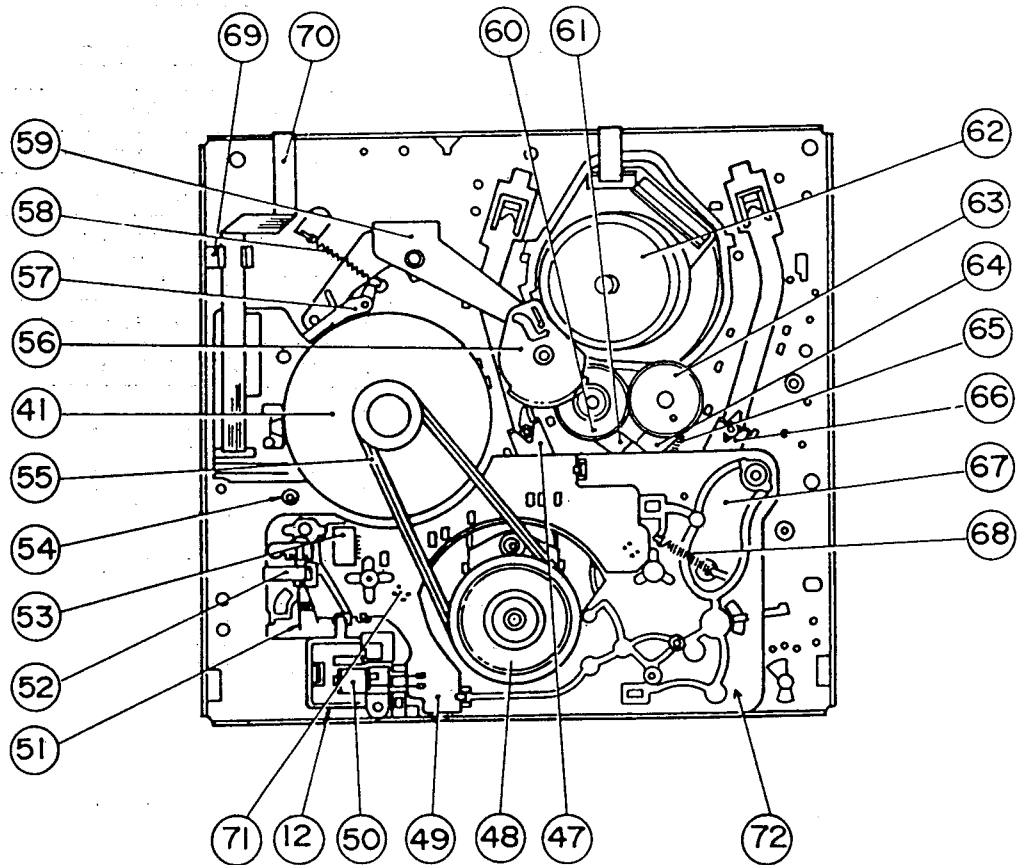

LOCATION LIST OF MECHANICAL PARTS

No.	Part Name	No.	Part Name
1	Main chassis ass'y	38	Pinch roller lever ass'y
2	A/C head arm	39	Relay shifter lever
3	Half-loading-lever spring	40	Retaining guide
4	Half-loading lever	41	Capstan D.D.motor
5	Main take-up brake lever	42	Reverse guide
6	Cassette LED	43	Reverse guide spring
7	Idler gear ass'y	44	Take-up reel disk
8	Cassette control earth spring	45	Video search brake lever
9	Main supply brake lever	46	Loading belt
10	Supply reel disk	47	Take-up pole base slider
11	Back tension lever	48	Reel pulley
12	Brake shifter	49	Reel sensor PWB
13	Tension spring hook plate	50	Brake solenoid
14	Tension spring	51	Shifter spring
15	Tension release lever	52	Shifter spring cover
16	Tension band ass'y	53	Connector
17	Auxiliary fast forward brake lever	54	Reverse guide spring
18	Tension arm ass'y	55	Reel belt
19	Supply pole base ass'y	56	Loading relay gear
20	Guide roller ass'y	57	Slow brake lever
21	Supply impedance roller	58	Slow brake spring
22	Full erase head ass'y	59	Relay gear drive lever
23	Supply loading rail	60	Take-up loading gear
24	Drum base	61	Take-up loading arm ass'y
25	Earth brush ass'y	62	Drum D.D. motor ass'y
26	Drum ass'y	63	Supply loading gear
27	Take-up pole base ass'y	64	Supply loading arm ass'y
28	Take-up loading rail	65	Loading reciprocating spring
29	A/C head ass'y	66	Supply pole base slider
30	X-position adjusting nut	67	Reel block chassis
31	Half-loading reciprocating spring	68	Auxiliary fast forward brake spring
32	Half-loading reciprocating lever	69	Full flat cable holder
33	Half-loading drive lever	70	Full flat cable(Drum D.D. motor)
34	Loading block ass'y	71	Reel sensor
35	Cam switch	72	Reel block
36	Loading motor	73	Main brake spring
37	Master cam	74	Dew sensor







ADJUSTMENT, REPLACEMENT, ASSEMBLY AND CLEANING OF MECHANICAL UNITS





Here we will describe a relatively simple service work in the field, not referring to the more complicated repairs which would require the use of special equipment and tools (drum assembly or replacement, for example).

We are sure that the easy-to-handle tools listed below would be more than handy for periodical maintenance to keep the machine in its original efficient condition.

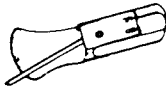
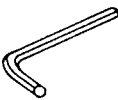
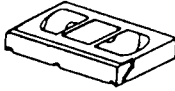
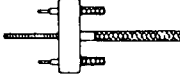
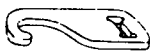
TOOLS NECESSARY FOR ADJUSTING THE MECHANICAL UNITS

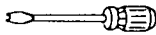
The following tools are required for proper service and satisfactory repair.

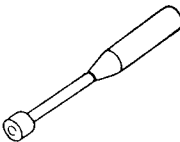
No.	Jig Item	Part No.	Code	Configuration	Remarks
1	Reel Disk Height Adjusting Jig	JiGRH0002	BR		These Jigs are used for checking and adjusting the reel disk height.
2	Master Plane Jig	JiGMP0001	BY		
3	A/C Head Tilt Adjusting Jig	JiGACH-F18	BU		This Jig is used for setting the A/C head tilt.
4	Torque Gauge (90g)	JiGTG0090	CM		These Jigs are used for checking and adjusting the torque of take-up and supply reel disks.
	Torque Gauge (1.2 kg)	JiGTG1200	CN		
5	Gauge Head	JiGTH0006	AW		
6	Cassette Torque Meter	JiGVHT-063	CZ		This cassette torque meter is used for checking and adjusting the torque of take-up and supply reel and for measuring tape back tension.
7	Tension Gauge (300g)	JiGSG0300	BF		There are two Gauges used for the tension measurements, 300 g and 2.0 kg.
	Tension Gauge (2.0 kg)	JiGSG2000	BS		
8	Hex Wrench (0.9 mm)	JiGHW0009	AE		These Jigs are used for loosening or tightening special Hexagon type screws.
	Hex Wrench (1.2 mm)	JiGHW0012	AE		
	Hex Wrench (1.5 mm)	JiGHW0015	AE		
9	Alignment Tape (PAL)	VROCPSV	CK		This tape is especially used for electrical fine adjustment.
10	Drum Replacing Jig	JiGDT-0001	BG		This is used for replacement of the VCR's upper drum.
11	Tension Gauge Adapter	JiGADP003	BK		This Jig is used for the tension gauge. Rotary Transformer Clearance Adjusting Jig.

No.	Jig Item	Part No.	Code	Configuration	Remarks
12	Special Bladed Screwdriver	JiGDRIVERH-4	AP		This Screwdriver is used for adjusting the guide roller height and X-position.
13	Tension Band and Plate Adjusting Jig	JiGDRIVER-6	BM		This Jig is used for adjusting the tension band and tension plate.
14	Torque Driver	JiGTD1200	CB		This is used to screw down resin-made parts: the specified torque is 5 kg.
15	Box Driver	JiGDRIVER110-7	AS		This Jig is used for height adjustment of the A/C head.
		JiGDRIVER110-4	AV		This Jig is used for height adjustment of the retaining guide.
16	Retaining Guide Height Adjusting Jig	JiGGH-F18	BU		This Jig is used for height adjustment of the retaining guide.
17	Reverse Guide Height Adjusting Jig	JiGRVGH-F18	BU		This Jig is used for height adjustment of the reverse guide.

NOTE:

Current JiGMA0001 contains Master Plane (JiGMP0001) and Disk Height Adjusting Jig (JiGRH0001). Even though new Disk Height Adjusting Jig (JiGRH0002) covers greater height, this new Jig (JiGRH0002) can be used for current JiGRH0001, but current Jig (JiGRH0001) cannot be used as JiGRH0002. Master Plane (JiGMP0001) can be used with JiGRH0001 and JiGRH0002 as well.

SERVICE TOOLS

JiGRH0002	4822 395 80215	Reel disc height adjustment
JiGMP0001	4822 395 80193	Master plane jig
JiGACH-F18	4822 395 80301	A/C head tilt adjustment
JiGTG0090	4822 395 80196	Torque gauge 909
JiGTG1200	4822 395 80197	Torque gauge 1,2 kg.
JiGTH0006	4822 395 80198	Gauge head
JiGVHT-063	4822 395 80217	Cass. torque meter
JiGSG0300	4822 395 80194	Tension gauge 300 gr.
JiGSG2000	4822 395 80216	Tension gauge 2 kgr.
JiGHW0009	4822 395 80189	Hex wrench 0.9 mm
JiGHW0012	4822 395 80191	Hex wrench 1.2 mm
JiGHW0015	4822 395 80192	Hex wrench 1.5 mm
VROCPSV	4822 397 30107	Alignment tape PAL
JiGDT-0001	4822 395 80186	Drum replacing jig
JiGADP003	4822 395 80213	Tension gauge adapter
JiGDRIVERH-4	4822 395 50189	Special screw driver
JiGDRIVER-6	4822 395 50191	Tension band adjustment
JiGTD1200	4822 395 54047	Torque screw driver
JiGDRIVER110-7	4822 395 50192	Box driver
JiGDRIVER110-4	4822 395 50273	Box driver
JiGGH-F18	4822 395 80302	Ret guide height adjustment
JiGRVGH-F18	4822 395 80303	Rev guide height adjustment

8
TROUBLESHOOTING GUIDE

■ TROUBLES OF CONTROL SYSTEM (SERVO, SYSTEM CONTROLLER CIRCUIT)

No.	Problems	Probable causes and countermeasures
1.	No power is supplied.	<ul style="list-style-type: none"> ● The fuse is blown out; check if there occurs a shortcircuit in the internal circuit. ● Check if there are produced AT5V, Motor 12V and AT9V in the power circuit; if not, this means that the power circuit is defective. ● Check if the system controller (IC801) is normally functioning; check if there are produced reset signals (ACL) at pin 45 of IC801 and clock signal at pins 46 and 47 of IC801. ● Check if the power control signal (Low level) goes out of pin 19 of IC801.
2.	No operation is available.	<ul style="list-style-type: none"> ● Check if the end sensor signal (cassette housing side) and start sensor signal are applied to pins 56 and 57 of IC801 respectively. ● Check if the unit is in timer mode. ● Check if the unit is in sensor stop mode. ● The cam switch is poorly adjusted for its positioning.
3.	After tape lading, the unit is stopped with the tape kept wound over the drum, or the cassette can't be ejected.	<ul style="list-style-type: none"> ● The cam switch is poorly adjusted for its positioning. ● IC803 is defective.
4.	The unit will stop immediately after it is set in playback or record mode.	<ul style="list-style-type: none"> ● Check if the head switching pulse is applied to pin 3 (for the drum sensor) of IC801. ● Check if the drum motor is rotating. ● Check if the drum pulse generator's signal is applied to pin 4 of the servo circuit IC701
5.	The unit will stop a few seconds after it has been set in playback or record mode.	<ul style="list-style-type: none"> ● Check if the reel sensor pulse is applied to pin 58 (for the reel sensor) of IC801. ● Check if the reel motor is rotating. ● Check if the reel idler is stained or defective.
6.	The tape is not running (the tape is not taken up).	<ul style="list-style-type: none"> ● The reel idler is defective. ● The reel brake is defective.
7.	<ul style="list-style-type: none"> ● The unit stops sometimes during playback or recording. ● The tape can't be taken up when tape unloading. ● The tape is scratched when it is wound. ● Video search is impossible. 	<ul style="list-style-type: none"> ● Check if there are produced capstan motor control signals at the system controller (servo clock signal 38 of IC801, servo data signal at 39 of IC801, capstan motor pull up signal at pin 29 of IC801, capstan motor unloading signal at pin 39 of IC801, loading motor control forward signal at pin 63 of IC801, cassette and loading motors reverse control signal at pin 62 of IC801). ● The video search circuit is defective. ● IC701 and IC702 are defective.
8.	Fine noises appear at the reproduced picture.	<ul style="list-style-type: none"> ● The playback phase generator MM control is misadjusted (R740).

No.	Problems	Probable causes and countermeasures
9.	Noises appear intermittently at the reproduced picture.	<ul style="list-style-type: none"> • Check for capstan servo circuit (capstan frequency generator's signal at pin 11 of IC701 and playback control signal at pin 42 of IC701)
10.	The picture collapses in the horizontal direction.	<ul style="list-style-type: none"> • The drum servo circuit is defective. • Check if there are drum frequency generator's signal applied to pin 7 of IC701 and drum phase generator's signal to pin 4 of IC701. • Check if there is reference signal (4.43MHz) at pin 22 of IC701.

• TROUBLES OF SOUND AND REPRODUCED PICTURE (Y/C AND AUDIO CIRCUIT)

No.	Problems	Probable causes and countermeasures
1.	No picture appears.	<ul style="list-style-type: none"> • Check if the video signal (E-E signal) is applied to pin 4 of IC201, if the video signal goes out of pin 10, and if proper voltage is applied to each pin of IC201). • Check if the video signal comes into pin 3 of IC2201 and goes out of pin 8 of IC2201 (in tuner mode). • Check if the E-E (L) signal is at low level at pin 26 of connector AX and pin 7 of IC2201.
	At E-E mode	
	At playback of standard tape.	<p>Make sure that there appears a normal picture at E-E mode.</p> <ul style="list-style-type: none"> • Check if the playback FM signal is applied to pin 7 of connector CE. • Check if the playback FM signal is applied to pins 19 and 20 of IC301. • Check if Vcc 5V is applied at pin 8 of IC401. • Check if the video signal (demodulator output) is given at pin 16 of IC401. • Check if the video signal is given at pin 1 of IC401. • Check if the base of Q202 is at high level (about 4V).
	At playback of the tape recorded by oneself.	<p>Before this checking, make sure that normal playback is possible with standard tape.</p> <ul style="list-style-type: none"> • Check if there is FM signal at pin 16 of IC401. • Check if there is video signal at pin 6 of IC201. • Check if there is video signal at pin 10 of IC201.
	No colour appears.	<ul style="list-style-type: none"> • Check if there is chroma signal at pin 30 of IC501. • APC is misadjusted (R506). It is not allowed to readjust them, this means that IC501 is defective. • Check if IC501 is normally functioning.
3.	The picture collapses when the tape recorded by oneself is played back.	<ul style="list-style-type: none"> • Check if there is a normal voltage at each pin of the head amplifier.
4.	Noises appear on the whole of picture when the tape recorded by oneself is played back.	<ul style="list-style-type: none"> • Check if there is a normal voltage at each pin of the head amplifier • Check the video head or replace it a new one.

No.	Problems	Probable causes and countermeasures
5.	Noises is noticeable at E-E mode or when the tape recorded by oneself is played back.	<ul style="list-style-type: none"> • The tuner and/or RF converter are defective. • Check if AT 5V is applied at pin 5 of the RF converter. • Check the coaxial cable between the tuner and the RF converter for breakage. • Disconnect the antenna cable to see if the DC voltage at the tuner's AGC terminal goes above 6V.
6.	Noise appear on the picture when the tape is played back with standard tape.	<ul style="list-style-type: none"> • Clean the video head or replace it a new one.
7.	There appears no E-E sound.	<ul style="list-style-type: none"> • First make sure the E-E picture appears as specified.(If not, the muting effect is produced.) • ALC at IC601 operates improperly. • Check if there is audio signal at pin 17 of IC601 • The audio muting circuit is defective.
8.	There appears no sound at playback mode.	<ul style="list-style-type: none"> • The audio head is defective. • Check if the control signal is applied. (If not, the muting effect is produced.) • Ckeck if playback audio signal is applied to pin 7 of IC601 and goes out of pin 17.
9.	Sound is distorted.	<ul style="list-style-type: none"> • The audio head is magnetized or defective. • Bias current is insufficient.
10.	The reasonance in the recording or playback is incorrect.	<ul style="list-style-type: none"> • The audio head is magnetized or defective. • Bias oscillator circuit is defective.
11.	Recording is impossible.	<ul style="list-style-type: none"> • Bias oscillator circuit is not normally functioning. • Ckeck if pin 12 of K602 (bias control 9V) is at high level.
12.	Noise and hum appear frequently during playback or recording.	<ul style="list-style-type: none"> • The audio head is defective.

MECHANICAL PARTS REQUIRING PERIODICAL INSPECTION

Use the following table as a guide to maintain the mechanical parts in good operating condition.

Parts	Maintained every	500 hrs.	1000 hrs.	1500 hrs.	2000 hrs.	3000 hrs.	Remarks
Guide roller ass'y		□	□	□	□	□	Abnormal rotation or significant vibration requires replacement.
Supply impedance roller		□	□	□	□	□	
Supply impedance roller (inner)			□		□	□	Clean with pure high quality isopropyl alcohol.
Supply impedance roller flange		□	□	□	□	□	Clean tape contact area with the specified cleaning liquid.
Retaining guide		□	□	□	□	□	
Slant pole		□	□	□	□	□	
Video head		□	○□	□	○□	○□	Clean tape contact area with the specified cleaning liquid.
Full-erase head		□	□	□	□	□	
A/C head		□	□	□	□	□	
Pinch roller		□	□	□	□	○□	Clean rubber and rubber contact area with the specified cleaning liquid.
Reel belt			□		□		
Loading belt			□		○		
Capstan loading belt			□		○		
Reel block*					○		
Tension band ass'y						○	
*See the table below for servicing the reel block parts.							
Supply/take-up reel disks			□△		□△○		Clean with pure high quality isopropyl alcohol.
Video serch brake lever					○		
Idler gear ass'y					○		
Reel idler			□△		□△		
Main supply/take-up brake levers					○		

NOTE: ○: Part replacement.
 □: Cleaning (For cleaning, use a lint-free cloth dampened with pure isopropyl alcohol).
 △: Oil refilling (The indicated point should be lubricated with high quality spindle oil every 1000 hrs).

This model has no adjusting parts for torques, tension, etc. If the reading is outside the specified range, clean or replace the part.

REMOVAL AND REASSEMBLY OF CASSETTE HOUSING CONTROL ASSEMBLY

Notes:

1. During removal and reassembly, be careful not to strike the nearby guide pin, drum, etc.
2. Before removal or reassembly, be sure to unplug the recorder from the AC outlet.
3. When removing and attaching the cassette loading belt, be careful to keep it free from grease.

• Removal

1. Put the unit in the cassette eject position.
2. Remove the cassette loading belt ①.
3. Disconnect the FFC (Full Flat Cable) ② at the right side of the cassette housing control assembly.

Note: Be careful not to break the FFC.

4. Remove the two cassette housing installation screws.
5. Move the cassette housing control assembly (Fig. 1-1) in the direction of arrow → ③, and pull it out straight upward.

• Reassembly

1. Insert the tabs of the cassette housing control assembly into the mechanism chassis, move it in the direction of arrow → ④, and secure temporarily.
Check to see if the cassette housing control assembly is in the correct position, and then tighten the two screws (XHPS330P06WS0).
2. Attach the cassette loading belt ①.
3. Connect the FFC ② at the right side of the cassette housing control assembly.

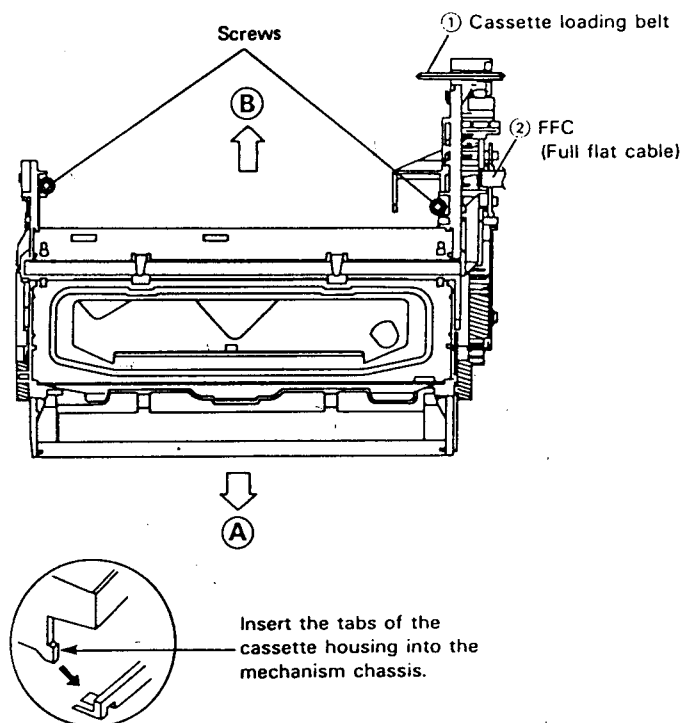

Figure 1-1.

REPLACEMENT OF WORM WHEEL ASSEMBLY

• Removal (Fig. 1 - 2)

1. Unsolder the cassette switch connector from the start sensor PWB ①
2. Release the two catches ⑤ on the cassette housing frame (R), and remove the PWB.
3. Unscrew one B tight screw ② to detach the worm bracket ③.

Note: The bearing ④ can come off position too. So be careful not to let the bearing fall.

4. Remove the worm shaft assembly ⑤, pulley ⑥ and cassette loading belt ⑦ all from the cassette housing frame (R).
5. Finally pull the worm wheel assembly out of the boss of the cassette housing frame (R).

• Reassembly (Fig. 1-2)

1. Turn the phase gear ⑧ clockwise until the slider comes to a halt in the cassette insertion direction.
2. Set up the worm wheel gear assembly onto the boss on the cassette housing frame (R), matching the mark ⑨ on the phase gear ⑧ with the mark ⑩ on the worm wheel gear.

Note: Make sure that the slider pin is in the groove of the drive gear arm.

3. Install the pulley ⑥ and apply the cassette loading belt ⑦ both on the worm shaft assembly ⑤. Couple the clutch ⑪ to the clutch lever ⑨. And mount them together in the cassette housing frame (R).
4. Attach the worm bracket ③ to the worm shaft assembly ⑤. Place them onto the boss on the cassette housing frame (R).
5. Tighten one B tight screw ②.

Note: Make sure that the parts ③ and ④ of the cassette housing frame (R) are properly engaged with the parts ⑤ and ⑥ of the worm bracket ③.

6. Hook the start sensor PWB ① on the two positions ④ on the cassette housing frame (R).
Note: Check that the switch connector is right in the cassette switch mounting hole ⑤.
7. Finally resolder the cassette switch connector to the start sensor PWB.

Notes:

1. Do not overtighten the B tight screw (no more than 5.0 ± 0.5 kg. cm), because otherwise the lower threads of the screw hole at the resin-made boss may be broken.
2. Keep in mind that the clutch switching lever should be in the correct positional relation. The mechanism might malfunction even if the lever comes slightly out of position.

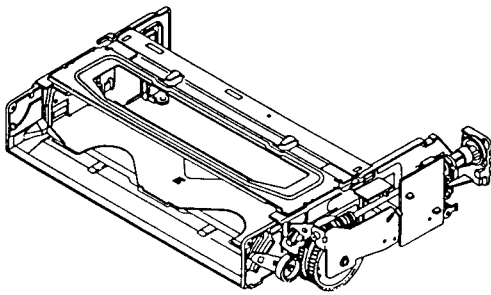

Figure 1-2 (a).

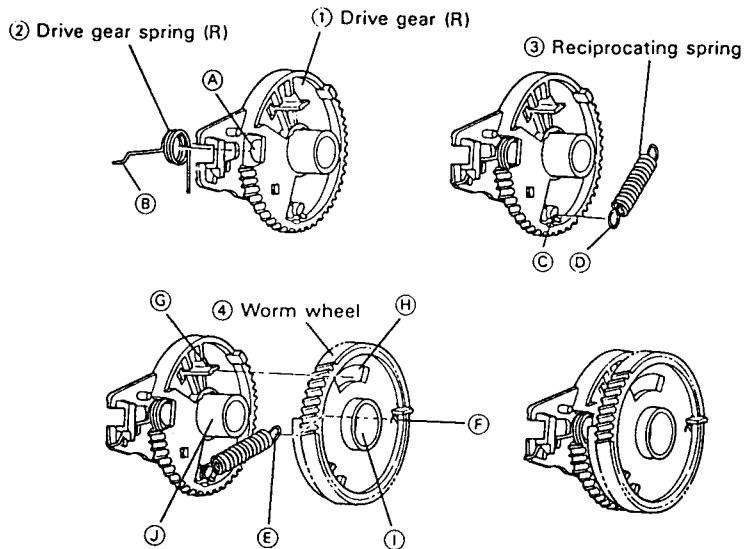

Figure 1-3.

REPLACEMENT OF CASSETTE LOADING BELT

● Replacement (Fig. 1-4)

1. Remove the start sensor PWB and worm bracket from the cassette housing frame (R).
2. Remove the worm shaft assembly, pulley and cassette loading belt from the cassette housing frame (R).
3. Replace the cassette loading belt with a new one.

Notes:

1. Do not overtighten the B tight screw which holds the worm bracket in position. The specified tightening torque is 5.0 ± 0.5 kg. cm.
2. Make sure that the cassette loading belt, being applied in the cassette housing frame (R), is free from grease. If stained with grease, clean the belt with the specific cleaning liquid.
3. Finally check the clutch switching lever for its specified points.

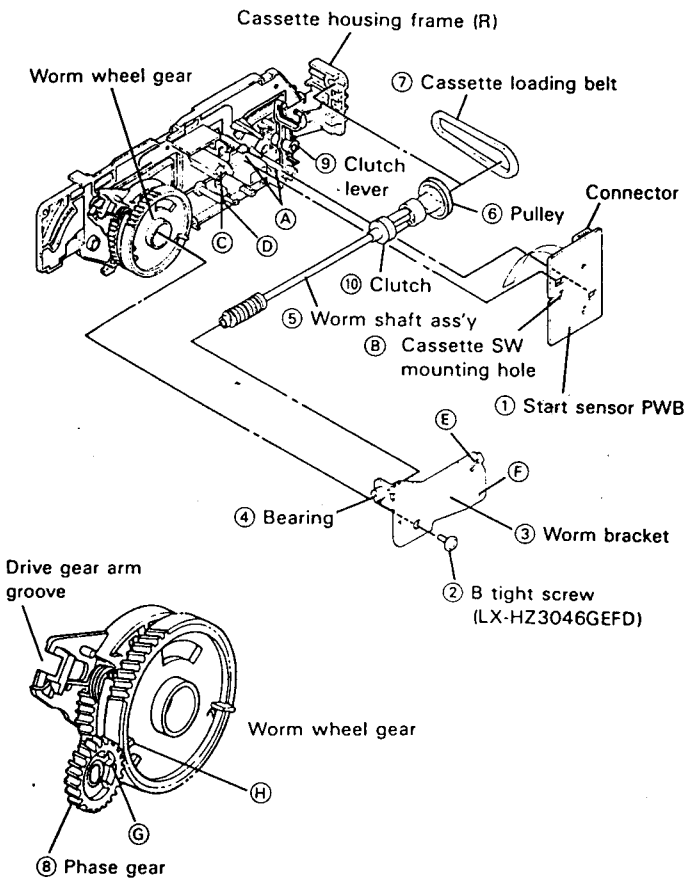

Figure 1-2 (b).

● Reassembly of drive gear (Fig.1- 3)

1. Pass the tip B of the drive gear spring (R) 2 through the square hole A of the drive gear (R) 1 to the hook the spring in position.
2. Hook one end D of the reciprocating spring 3 to the catch C of the drive gear (R) 1.
3. Hook the other end E of the reciprocating spring 3 to the catch F of the worm wheel 4.
4. Fit the drive gear (R) 1 to the worm wheel 4 so that the catch G and boss J on the drive gear (R) are exactly in the square hole H and round hole I, respectively, in the worm wheel.

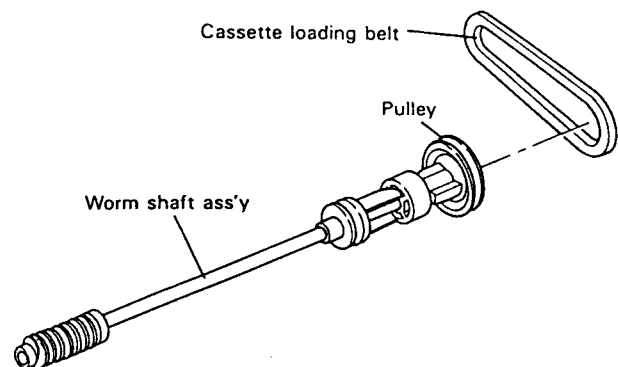

Figure 1-4.

CHECKING THE CLUTCH SWITCHING LEVER

• Checking (Fig. 1-5)

When removing and attaching the clutch switching lever from and to the mechanism chassis, check to see if the lever is in the position as shown below. If out of this position, malfunction might result.

1. First make sure that the rib **(A)** of the drive gear (R) **(1)** and the tip **(B)** of the switch lever **(2)** are in their correct positions.
2. Check also that the rib **(C)** of the cassette housing frame (R) and the catch **(D)** of the clutch lock lever **(3)** are in their proper positions.
3. Finally be sure that the positional relations between the clutch lever **(4)** and the clutch **(5)**, as well as between the clutch **(5)** and the pulley **(6)**, are as specified.

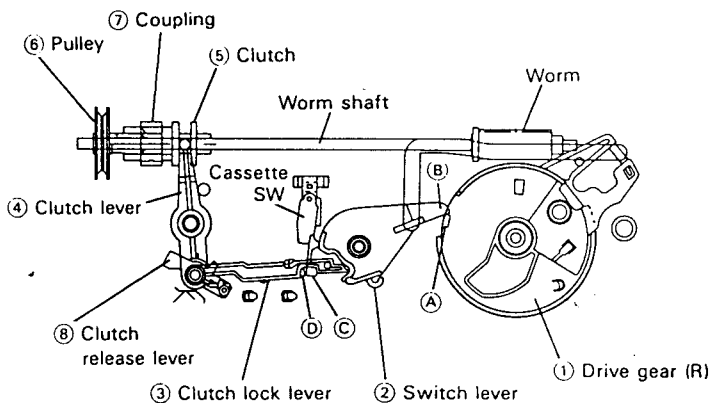

Figure 1-5.

• Resetting (Fig. 1-6)

Take the following steps to reset the clutch **(5)** if it is unlocked or if the switch lever **(2)** and clutch lock lever **(3)** are unlocked.

1. Turn the coupling **(7)** clockwise (as viewed from the front of the set) until the slider comes to the position indicated below.

Note: Notice that the slider is equipped with a lock mechanism. Unlock the slider, therefore, before shifting the slider.

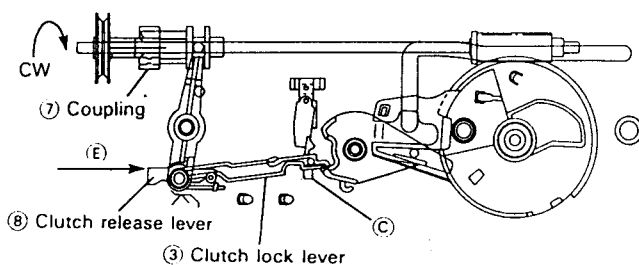

Figure 1-6.

2. Now push the clutch release lever **(8)** in the direction of arrow **(E)** by hand until the clutch lock lever **(3)** becomes tightly locked by the part **(C)** of the cassette housing frame (R).
3. Then turn the coupling **(7)** counterclockwise until the slider reaches the cassette insertion opening and the reciprocating spring is activated.
Note: There is no need to lock the slider. Just keep shifting the slider.

REPLACEMENT OF LOCK RELEASE LEVER

• Removal (Fig. 1-7)

1. Turn the coupling clockwise until the slider **(1)** comes to the cassette down position.
Note: Before shifting, unlock the slider.
2. Slightly widen the cassette housing frames (R) and (L) to unhook the parts **(A)** of the slider holders (R) and (L) off the grooves of the above frames.
3. Press the catch **(B)** on the slider holder (R) **(2)**, and let the slider **(1)** go off this holder in the direction of arrow **(C)**.
4. Take the lock release lever **(3)** out of the slider holder (R) **(2)**.

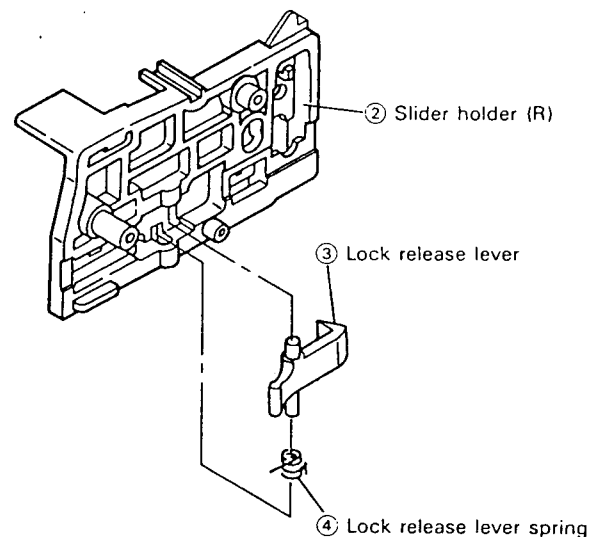
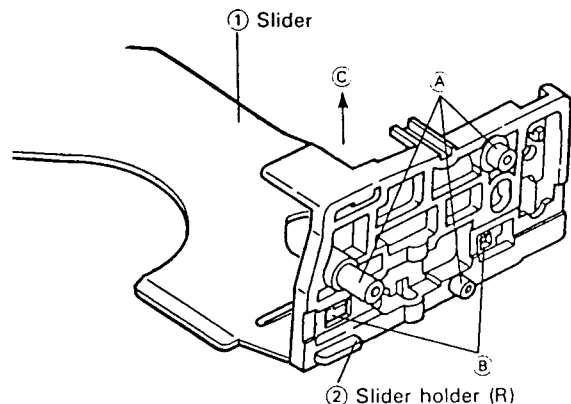

Figure 1-7.

● Reassembly (Fig. 1-7)

1. Attach the lock release lever ③ to the slider holder (R) ②.
2. Fit the slider holder (R) ② to the slider ①.
3. Slightly widen the cassette housing frames (R) and (L), and set the parts ④ of the slider holders (R) and (L) to the grooves of the cassette housing frames (R) and (L).

Note: Make sure of the following fitting: Fitting between the parts ④ of the slider holders (R) and (L) and the grooves of the cassette housing frames (R) and (L), as well as between the drive gear arms and the slider holders (R) and (L).

4. Turn the coupling counterclockwise until the slider ① comes to the cassette insertion opening.

TO RUN A TAPE WITHOUT THE CASSETTE HOUSING CONTROL ASSEMBLY

1. Open the lid of a cassette tape by hand and hold it with a piece of vinyl tape.
2. Set the cassette tape in the tape mechanism. Then, stabilize the cassette tape with a weight (500g or less).

Note: The weight should not be more than 500g.

REMOVAL AND HEIGHT ADJUSTMENT OF REEL DISKS

● Removal of supply reel disk:

1. Remove the cassette housing control assembly.
2. Set the mechanism in the playback mode with no cassette tape in place. Unplug the power cord.
3. Remove the tension band ⑧.
4. Unscrew the screw ⑩ and release the cassette housing control ground spring ⑫ off the reel disk catch ①.
5. Release the supply reel disk catch ① and back tension lever ②. Pull out the supply reel disk ③ upward.

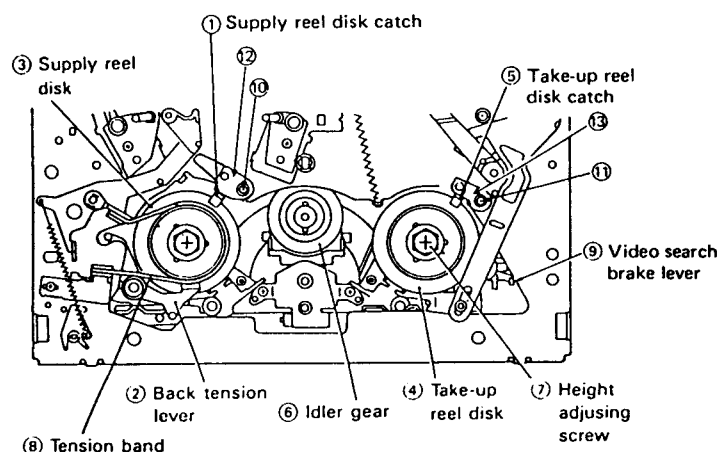

Figure 1-8.

● Removal of take-up reel disk:

1. Remove the cassette housing control assembly.
2. Set the mechanism in the playback mode with no cassette tape in place. Unplug the power cord.
3. Unscrew the screw ⑪ and release the take-up reel disk catch holder ⑬ off the reel disk catch ⑤.
4. Release the take-up reel disk catch ⑤. Pull out the take-up reel disk ④ upward.

Notes:

1. After replacing either of the reel disks, be sure to perform the height adjustment procedure.
2. Take care not to deform the tension hand.
3. Be careful not to deform the back tension lever, main supply / take - up brake levers, video search brake lever and auxiliary fast forward brake. (See pages 4 and 5.)
4. Check the tension pole position. (See page 15.)
5. Be careful not to damage the supply reel disk, take-up reel disk and idler gear ⑥.
6. Whenever replacing, clean and lubricate the reel disk shaft.

● Reassembly of supply reel disk:

1. Clean the reel disk shaft and apply oil (high quality spindle oil) to it, then install a new supply reel disk onto the shaft.
2. Replace the cassette housing control ground spring ⑫ in position and tighten up the screw ⑩.
3. Replace the tension band ⑧.
4. Adjust the reel disk height by using the master plane and reel disk height adjusting jig.

● Reassembly of take-up reel disk:

1. Clean the reel disk shaft and apply oil (high quality spindle oil) to it. Then, release the video search brake lever and install a new take - up reel disk onto the shaft.
2. Replace the take-up reel disk catch holder ⑬ in position and tighten up the screw ⑪.
3. Adjust the reel disk height by using the master plane and reel disk height adjusting jig.

Notes:

1. During removal and reassembly, be careful not to damage the reel disks, reel shafts, idler gear and brake levers.
2. After reassembly, check the back tension in video search rewind mode (see page 14) and checking the brake torque (see page 16)

HEIGHT ADJUSTMENT

1. Remove the cassette housing assembly, and place the master plane onto the mechanism unit as shown in Fig.1-9 (a), taking care not to hit the drum.
2. Ensure that the reel disk is lower than the part ① but higher than the part ② of Fig. 1-9 (b), by using the reel disk height adjusting jig. If the height is not correct, adjust the height adjusting screw.

Note: Whenever replacing the reel disk, perform the height adjustment.

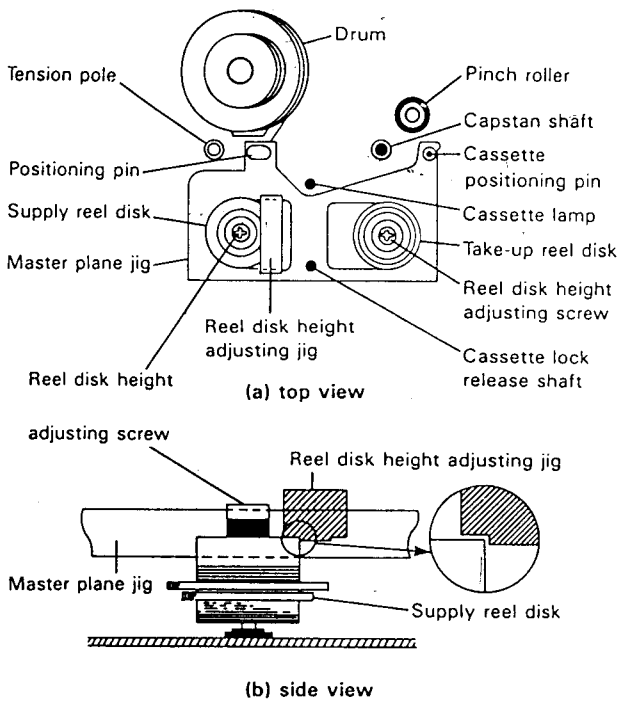

Figure 1-9.

CHECKING AND ADJUSTMENT OF TAKE-UP TORQUE IN FAST-FORWARD MODE

Notes:

1. When setting the torque gauge on the take-up reel disk and pushing the fast-forward button to start the reel disk turning, take care that the torque gauge does not fly off.
2. The checking and adjustment should be carried out without a video cassette tape in place.

• **Checking**

1. Remove the cassette housing assembly.
2. Place the torque gauge on the take-up reel disk and push the fast-forward button to place the unit in the fast-forward mode.
3. Turn the torque gauge slowly (one rotation every 2 to 3 seconds) by hand in the take-up direction and check that it indicates 700 g.cm or more.

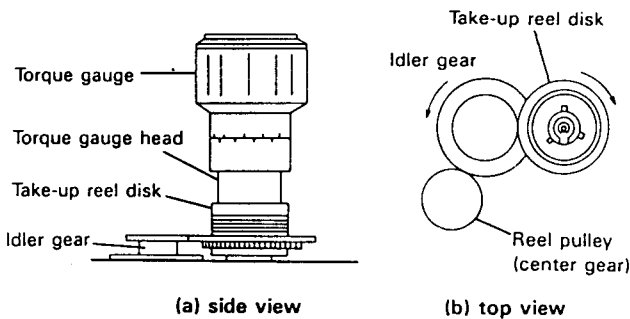

Figure 1-10.

• **Adjustment**

If the take-up torque is outside the specified range, clean the capstan D.D. motor pulley, reel belt and reel pulley with cleaning liquid, then recheck the torque.

If the take-up torque is still out of specification, replace the reel belt.

CHECKING AND ADJUSTMENT OF TAKE-UP TORQUE IN REWIND MODE

Notes:

1. When setting the torque gauge on the supply reel disk and pushing the rewind button to start the reel disk turning, take care that the torque gauge does not fly off.
2. When checking the take-up torque, do not keep the reel disk locked for a longer time.

• **Checking**

1. Remove the cassette housing assembly.
2. Place the torque gauge on the supply reel disk and push the rewind button to place the unit in the rewind mode.
3. Turn the torque gauge slowly (one rotation every 2 to 3 seconds) by hand in the take-up direction and check that it indicates 700 g.cm or more.

• **Adjustment**

If the take-up torque is outside the specified range clean the capstan DD motor pulley, reel belt and reel pulley with cleaning liquid, then recheck the torque.

If the take-up torque is still out of specification, replace the reel belt.

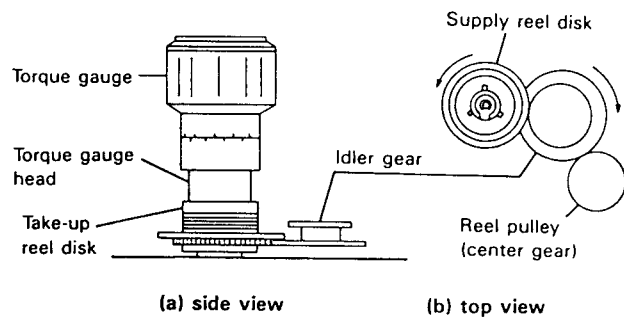

Figure 1-11.

CHECKING OF TAKE-UP TORQUE IN PLAY-BACK MODE

• **Checking**

Load a cassette torque meter (JiGVHT-063) into the unit and push the record button to place the unit in the record mode. Then check that the torque is as specified;

torque: 95 ± 30 g.cm

Not
T
r
t
r
1. l
t
2. f
i
CH
SE
•
NC
1.
C
TI
N
•
1.
2.
3.

Note:

The measured torque fluctuates due to the rotational deviation of the reel drive unit. Use the center of the fluctuating range as the measured value.

1. If the take-up torque in playback mode is outside the specified value, replace the take-up reel disk.
2. Push the record button to place the unit in the record mode, and check that the take-up torque is within the specified range.

CHECKING OF TAKE-UP TORQUE IN VIDEO SEARCH REWIND MODE

- **Checking**

Load a cassette torque meter (JiGVHT-O63) into the unit and push the play and video search rewind buttons to place unit in the video search rewind mode.

Then check that the torque is as specified;

- torque in video search rewind mode : 170 ± 40 g.cm

Note:

The measured torque fluctuates due to the rotational deviation of the supply reel disk. Use the center of the fluctuating range as the measured value.

1. If the take-up torque in video search rewind mode is outside the specified range, replace the supply reel disk.

CHECKING THE FAST FORWARD BACK TENSION

Note:

Set the torque gauge securely on the supply reel disk; if the torque gauge is loose above the reel disk, an inaccurate measurement will result.

Checking

1. Remove the cassette housing assembly.
2. Push the fast forward button to place the unit in the fast forward mode.
3. Place the torque gauge on the supply reel disk, and turn it clockwise very slowly (one rotation every 2 to 3 seconds) and check that the torque is within 15 ± 5 g.cm.

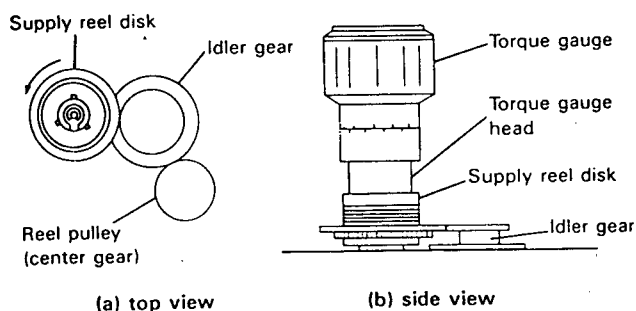

Figure 1-12.

CHECKING THE REWIND BACK TENSION

Note:

Set the torque gauge securely on the take-up reel disk; if the torque gauge is loose above the reel disk, an inaccurate measurement will result.

- **Checking**

1. Remove the cassette housing assembly.
2. Push the rewind button to place the unit in the rewind mode.
3. Place the torque gauge on the take-up reel disk, and turn it counterclockwise very slowly (one rotation every 2 to 3 seconds) and check that the torque is within 15 ± 5 g.cm.

CHECKING THE VIDEO SEARCH REWIND BACK TENSION

Note:

Set the torque gauge securely on the take-up reel disk; if the torque gauge is loose above the reel disk, an inaccurate measurement will result.

- **Checking**

1. Remove the cassette housing assembly.
2. Push the play button to place the unit in the playback mode.
3. Push the video search rewind button to place the unit in the video search rewind mode.
4. Place the torque gauge on the take-up reel disk, and turn it counterclockwise very slowly (one rotation every 2 to 3 seconds) and check that the torque is within 40 ± 10 g.cm.

CHECKING THE PINCH ROLLER PRESSURE

1. Remove the cassette housing assembly.
2. Push the play button to place the unit in the playback mode.
3. Hook the tension gauge adapter around the pinch roller shaft.
4. Using a tension gauge, pull the pinch roller in the direction of arrow \rightarrow (A) so that the pinch roller moves away from the capstan shaft.
5. Gradually release the pressure in the direction of arrow \rightarrow (B) to allow the pinch roller to touch the capstan shaft. When the pinch roller just touches the capstan shaft, read the indication on the gauge.
6. Check that the reading of the tension gauge is in the range of 1000 to 1200 gr.

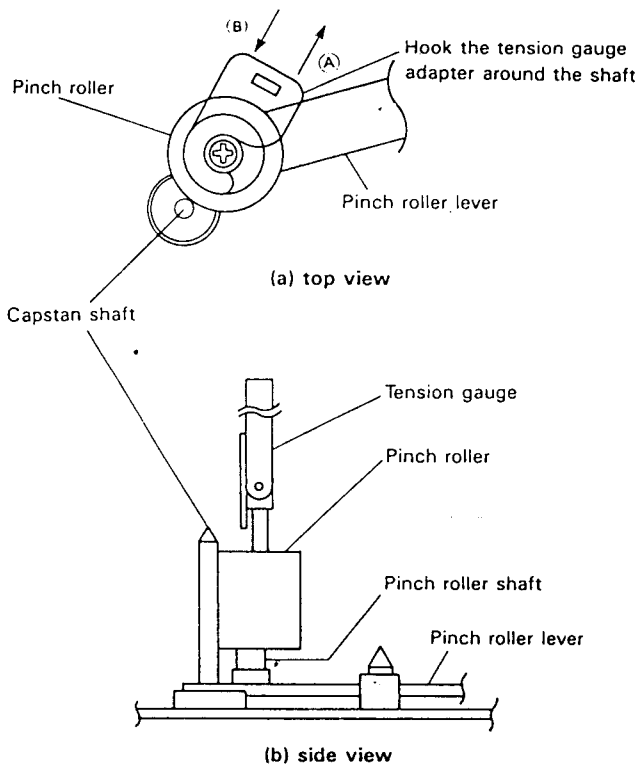

Figure 1-13.

ADJUSTMENT OF TENSION POLE

● Position checking (Fig. 1-14)

1. Remove the cassette housing assembly.
2. Set a video cassette tape and push the record button to place the unit in the record mode.
3. The pole bases (see page 4; item 19 and 27.) operate to bring the tape outside the cassette housing and simultaneously the tension pole moves to the left, loading the tape. At that time (loading mode), check the position of the tension pole.

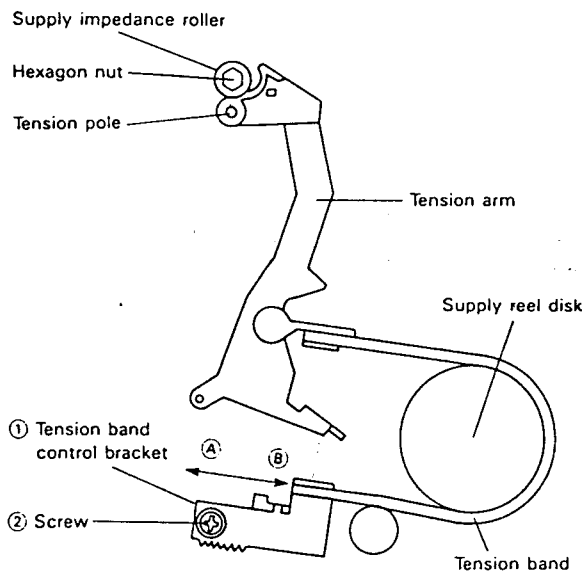

Figure 1-14.

4. At the end of the tape (E-180), check that the tension pole's center is aligned with the supply impedance roller's center.
5. Check that the tape is neither curled against the flange of the supply impedance roller nor mounted over it.
6. During the video search rewind mode with no cassette tape in place, check the supply reel disk is free of the tension band.

● Position adjustment (Fig. 1-15)

1. If the tension pole is at the right of the supply impedance roller's center, shift the tension band control bracket ① in the direction of arrow → ②, and tighten the screw ③.
2. If the tension pole is at the left of the supply impedance roller's center, shift the tension band control bracket ① in the direction of arrow → ④ and tighten the screw ③.

ADJUSTMENT OF RECORD/PLAYBACK BACK TENSION

● Checking

1. Remove the cassette housing assembly.
2. Put a torque cassette meter into the unit.
3. Push the record button to place the unit in the record mode. Check that the reading of the cassette meter is 23 to 28 g.cm.
4. Make sure the video cassette tape is wound over the retaining guide.
5. Make sure that the tape is not slack nor damaged at both ends.

● Adjustment (Fig. 1-15)

1. If the back tension is lower than specified, move the tension spring hook plate ① in the direction of arrow → ④ so that the protuberance behind be tight in the hole.
2. If the back tension is higher than specified, move the tension spring hook plate ① in the direction of arrow → ③ so that the protuberance behind be tight in the hole.

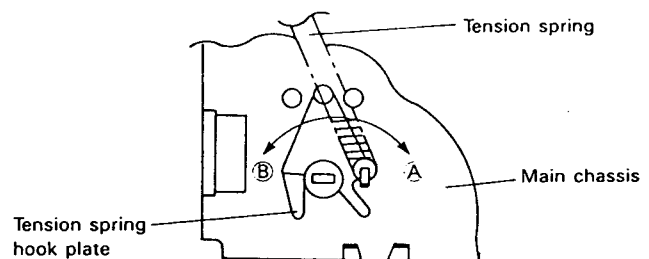

Figure 1-15.

CHECKING THE BRAKE TORQUE

A) Checking the brake torque at the supply side.

• Checking

1. Remove the cassette housing assembly.
2. Check that the mechanism is in the stop mode.
Note: The stop mode is brought about by unplugging the power cord with the mechanism in the fast forward or rewind mode.
3. Separate the idler gear from the supply reel disk and place the torque gauge on the supply reel disk.
4. Slowly rotate the torque gauge in the clockwise (CW) direction of the supply brake so that the reel disk and the gauge needle rotate at the same speed. Do the same in the counterclockwise (CCW) direction of the supply brake. Check that the values are within the specified range (CW direction = 280 to 720 g.cm, CCW direction = 110 to 230 g.cm) and that the brake torque in the CW direction is at least twice as high as that in the CCW direction.

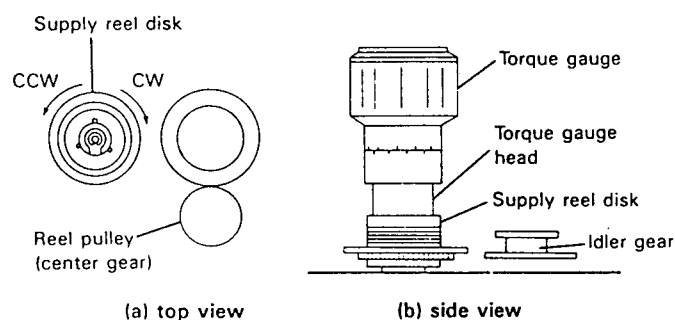

Figure 1-17.

• Adjustment

1. If the supply brake torque is outside the specified range (CW direction = 280 to 720 g.cm, CCW direction = 110 to 230 g.cm), clean the supply reel disk and brake lever felt, then recheck the torque.
2. If the supply brake torque is still outside the specified range, replace the main brake spring.

B) Checking the brake torque at the take-up side.

• Checking

1. Remove the cassette housing assembly.
2. Check that the mechanism is in the stop mode.
Note: The stop mode is brought about by unplugging the power cord with the mechanism in the fast forward to rewind mode.
3. Separate the idler gear from the take-up reel disk and place the torque gauge on the take-up reel disk.

- Slowly rotate the torque gauge in the CCW direction of the take-up brake so that the reel disk and the gauge needle rotate at the same speed. Do the same in the CW direction of the take-up brake. Check that the values are within the specified range (CCW direction = 280 to 720g.cm, CW direction = 90 to 200 g.cm) and that the brake torque in the CCW direction is at least twice as high as that in the CW direction.

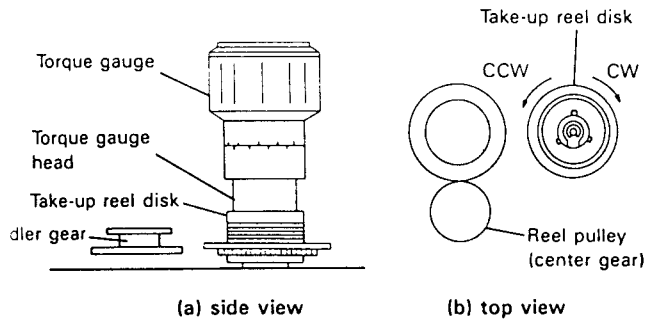

Figure 1-18.

● Adjustment

- If the take-up brake torque is outside the specified range (CCW direction = 280 to 720g.cm, CW direction = 90 to 200 g.cm), clean the take-up reel disk and brake lever felt, then recheck the torque.
- If the take-up brake torque is still outside the specified range, replace the main brake spring.

REPLACEMENT OF A/C (Audio/Control) HEAD

Note:

After replacement, perform the adjustment of tape drive train. Under any circumstances avoid touching the head (indicated by "⇒" in Fig. 1-20(c)).

● Replacement (See Figs. 1-19 and 1-20.)

- Loosen the tilt adjusting screw ⑥ by using Phillips screwdriver.
- Remove the azimuth adjusting screw ⑤ with a Phillips screwdriver.
- Remove the A/C head screw ④ with a Phillips screwdriver, paying attention to the spring ⑦ between the A/C head screw ④ and A/C head pedestal.

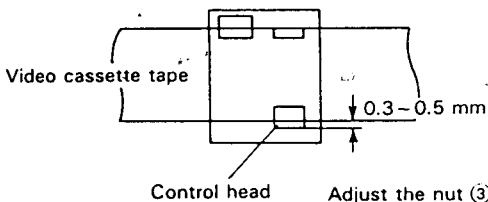

Adjust the nut ③ so that the control head is visible 0.3 to 0.5 mm below the bottom of the tape.

Figure 1-19.

- Remove the A/C head PWB ⑧ soldered to the A/C head assembly, and solder the A/C head PWB ⑧ onto a new A/C head assembly.
- The A/C head assembly ① is attached so that the A/C head arm ② and A/C head pedestal are roughly parallel to each other.

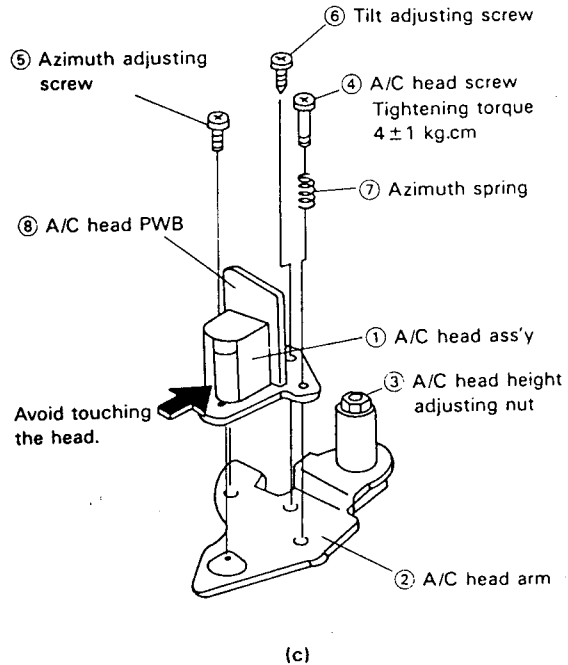
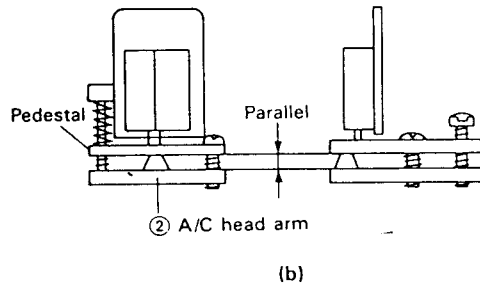
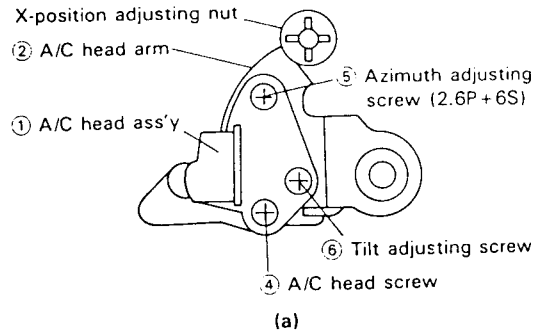

Figure 1-20.

6. Se
7. Pla
he
A/
dr
th
8. Se
th
as
ab
ur
he



6. Set the A/C head tilt angle according to Fig. 1-22.
7. Play an alignment tape and roughly adjust the height of the A/C head, visually, by turning the A/C head adjusting hexagon nut ③ with the box driver (JiGDRIVER110-7) until the tape comes to the position shown below. (See Fig. 1-19.)
8. Set the mechanism to the loading mode. Place the A/C head tilt adjusting jig on the main chassis as shown in Fig. 1-21. Slowly turn the tilt adjusting screw ⑥ with a Phillips screwdriver until there is no gap between the jig and the A/C head.

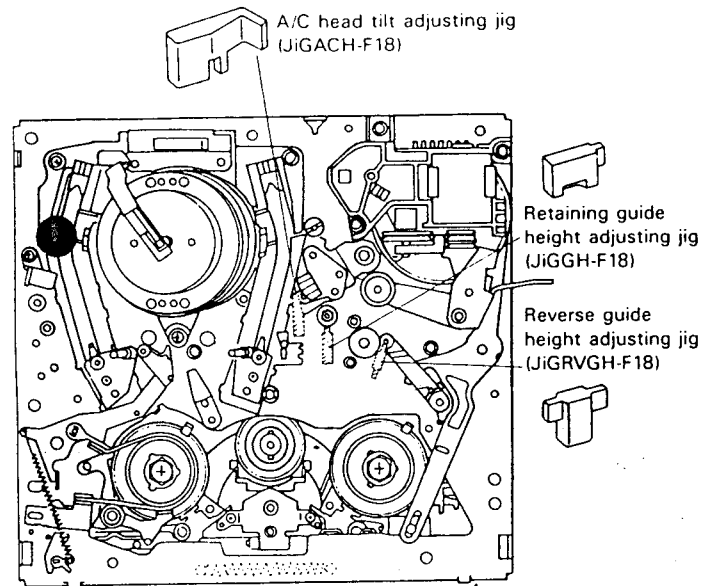

Figure 1-21.

Be sure there is no gap.

It is easier to see a gap, if a piece of white paper is placed behind the head and jig.

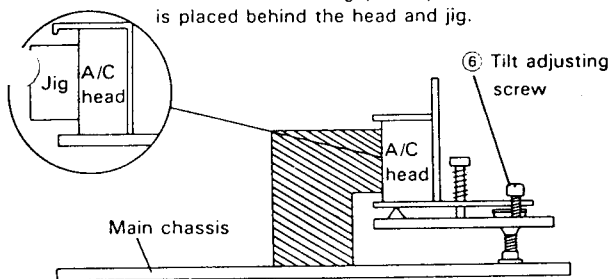

Figure 1-22.

HEIGHT ADJUSTMENT OF RETAINING GUIDE AND REVERSE GUIDE

● Adjustment

1. Before the rough adjustment of tape drive train, check that the retaining guide and reverse guide heights are within the specified values of Fig. 1-23, by using the special jigs.
2. If the retaining guide height is not correct, adjust the height with the box driver (JiGDRIVER110-4).
3. If the reverse guide height is not correct, use the height adjusting washers.

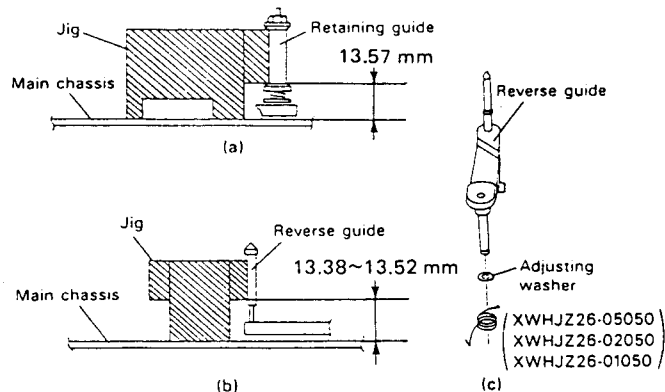

Figure 1-23.

ADJUSTMENT OF TAPE DRIVE TRAIN

1. Check and adjust the position of the tension pole and the back tension. (See pages 15)
2. Set the tilt angle of the A/C head as shown in Fig. 1-22.

Note:

If the A/C head is adjusted, check and set the tilt angle as in the case of replacement.

3. When the above adjustments have been completed, roughly adjust the tape drive train using an alignment tape.
 - a. Connect the oscilloscope to the test points for PB chroma output (TP501) and head switching pulse (TP502). Allow the PB CHROMA signal to be triggered by the head switching pulse of TP502.
 - b. Loosen the setscrew of the guide roller, and tighten it loosely by using the special bladed screwdriver (JiGDRIVERH-4) to such an extent that the guide roller turns smoothly.
 - c. Set the alignment tape (VROCPSV) on the reel disk.

Note:

Attach a 400 to 500g. weight to the cassette tape when a cassette tape is placed on the reel disk with the cassette housing assembly removed.

- d. Place the unit to the playback mode.
 - e. Observe the waveform of the PB chroma, and push the (+) or (-) tracking button to check for a flat PB chroma. This adjustment is satisfactory if a flat response is obtained on the waveform of the PB chroma when the (+) or (-) tracking button is pushed. If a flat response cannot be obtained roughly adjust the guide roller using the special bladed screwdriver until the PB chroma output is flat. While keeping the both (+) and (-) tracking buttons down, adjust the X-position adjusting nut so that the PB CHROMA envelope becomes almost maximum. In the case of rough adjustment, pay particular attention to the outlet side (see Fig. 1-24).
 - f. Adjust the retaining guide height so that the lower flange of the retaining guide touches the bottom edge of the tape. At that time, check that the tape is not curled nor wrinkled.
4. The A/C head height and azimuth are adjusted after rough adjustment of the tape drive train has been done.
 - a. Use the alignment tape and play back its audio 7kHz signal (monoscope pattern for video signal) and observe the audio output on an oscilloscope.
 - b. Adjust the azimuth adjusting screw so as to obtain the maximum audio output.
 - c. Use the alignment tape and play back its audio 1kHz signal (colour bar for video signal) and slowly rotate the A/C head height adjusting nut with the special box driver so as to obtain the maximum audio output.
 - d. After the height adjustment, use the alignment tape and play back its audio 7kHz signal (monoscope pattern for video signal) again and adjust the azimuth adjusting screw so as to obtain the maximum audio output. After this adjustment, apply glyptal to the screws and nuts to fix them.

5. The final adjustments of tape drive train and X-position are adjusted after adjustment of the A/C head has been completed.
 - a. Connect the oscilloscope to the test points for PB chroma output (TP501) and head switching pulse (TP502). Allow the PB CHROMA signal to be triggered by the head switching pulse of TP502.
 - b. Play back the tape drive train alignment tape (VROCPSV).
 - c. Finely adjust the guide roller's height, observing the envelope on the oscilloscope. Push the (+) or (-) tracking button while adjusting the guide roller, in order to obtain an envelope waveform which is as flat as possible. If the tape is above or below the helical lead, the PB chroma waveform will take the shape shown in Fig. 1-26. Adjust for maximum flatness of the envelope according to the figure.

Note:
Adjustment is made for CH-1 of switching pulse (low level). The broken lines indicate the envelope waveform when the tape does not run properly. Push the (+) or (-) tracking button to check the envelope waveform. After adjustment, tighten the setscrew of the guide roller firmly. Play back the alignment tape (VROCPSV) again in the unloading mode, and make sure that there is no change in the PB chroma output.

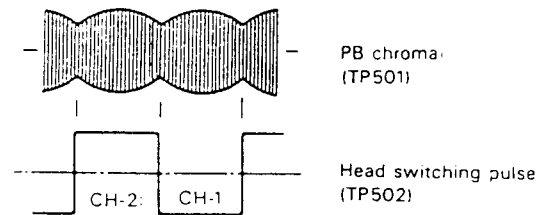

Figure 1-24.

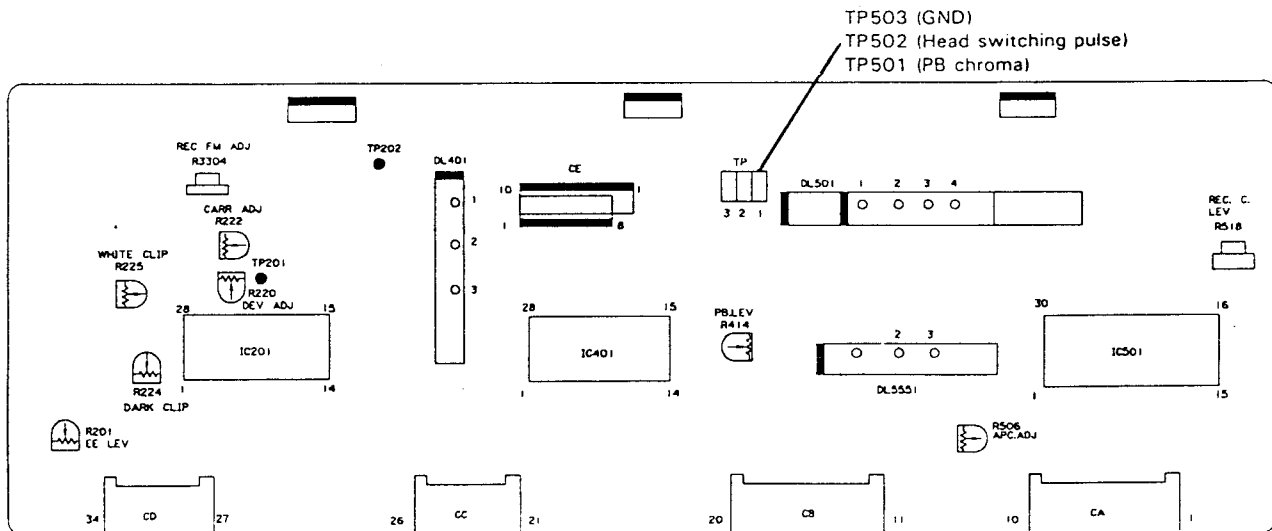

Figure 1-25.

	When the tape is above the helical lead.		When the tape is below the helical lead.	
	Supply side	Take-up side	Supply side	Take-up side
Adjustment	Supply side guide roller rotated in clockwise direction (lowers guide roller) to flatten envelope.	Take-up side guide roller rotated in clockwise direction (lowers guide roller) to flatten envelope.	Supply side guide roller rotated in counterclockwise direction (raises guide roller) to have the tape float above the helical lead. The supply side guide roller is then rotated in the clockwise direction to flatten the envelope.	Take-up side guide roller rotated in counterclockwise direction (raises guide roller) to have the tape float above the helical lead. The take-up side guide roller is then rotated in the clockwise direction to flatten the envelope.

Figure 1-26.

- d. Adjust the retaining guide height so that the lower flange of the retaining guide touches the bottom edge of the tape. At that time, check that the tape is not curled nor wrinkled.
- e. The X-position is adjusted after tape drive train adjustment.
Push the (+) and (-) tracking buttons at the same time to set the tracking buttons to the preset mode, and rotate the X-position adjusting nut shown in Fig. 1-27 with the special bladed screwdriver for maximum switching pulse low side envelope, and then adjust the A/C head position. Now adjust the play back switching point to $6.5 \pm 0.5H$. Check the flatness of envelope and sound by selfrecording.

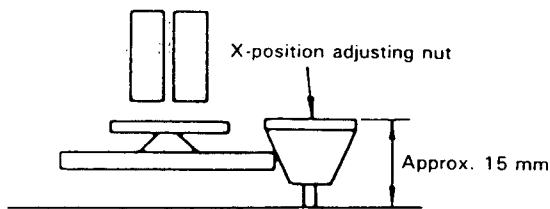

Figure 1-27.

REPLACEMENT OF UPPER DRUM

Note:

The engagement between the lower drum (outer diameter) and the upper drum (inner diameter) is very accurate, in the order of microns, and care should be paid to their replacement. Even a slight entry of foreign material will affect the accuracy of their reassembly.

● **Replacement (See Fig. 1-28)**

1. Unsolder the leads ① to ④ from the video head and remove them.
2. Remove the two screws ⑤ (brass screws with washers) using a Phillips screwdriver.

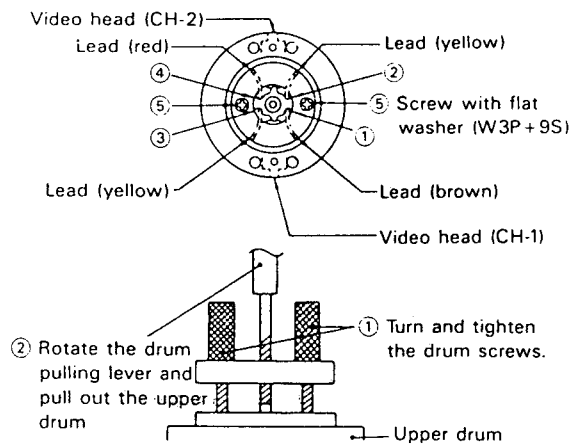

Figure 1-28.

RTV SERVIS
M. STJEPAN ČIZMAR
BEOGRAD - Bulinozavod
Telefon: (011) 156 7 23

3. Withdraw the upper drum by pulling it up with the upper drum replacement jig.

Notes:

1. Avoid touching the drum surface with bare hands.
2. Do not hit the screws when tightening them.

● **Reassembly**

1. Set a new drum for replacement, as shown in Fig. 1-28, and position the leads properly.

Notes:

1. Before replacing the upper drum, check that there are no scratches or dust on the edge or the outer surface of the lower drum.
2. Before replacing the upper drum, check that there are no scratches or dust on the edge or the inner surface of the upper drum.
3. On assembling these parts, slowly insert the upper drum onto the lower drum with the upmost care, so that the upper drum is not tilted.
4. When assembling these parts, do not allow foreign material to come between them.
5. Do not use excessive force when driving in the screws.
2. Fasten the upper drum in place with the two screws ⑤
3. Solder the leads ① to ④ at their respective pads.

Note:

Soldering should be performed quickly and carefully without touching adjacent patterns.

4. After replacement, be sure to check the tape drive train adjustment and the following.
 - Adjustment of the playback switching point (See page 26).
 - Checking and adjustment of the X-position (See page 27).
 - Adjustment of SP slow tracking preset (See page 26).

REPLACEMENT OF D.D. (DIRECT DRIVE) MOTOR

Note:

Put the unit in the cassette eject position.

● **Removal**

1. Remove the six screws from the bottom panel and remove the bottom panel.
2. Disconnect the drum D.D. motor lead connector.
3. Remove the two screws ① which hold the D.D. rotor assembly in place, using a Phillips screwdriver.
4. Remove the D.D. rotor assembly.
5. Remove the three screws ② which hold the D.D. stator assembly in place, using a Phillips screwdriver.
6. Remove the D.D. stator assembly.

● **Reassembly**

1. Place the D.D. stator assembly on top of the lower drum.
2. Secure the D.D. stator with the three screws ② using a Phillips screwdriver.

Note:

Be careful not to scratch the core, windings or Hall device.

3. Install the D.D. rotor assembly onto the drum shaft.

Note:

Install the assembly directly onto the direction of the shaft. (Refer to Fig. 1-29 for the installation direction.)

4. Secure the D.D. rotor assembly with the screws ①.
5. Connect the drum D.D. motor lead connector.
6. Install the bottom panel with six screws.

Note:

Be careful not to damage the upper drum or the video head.

7. After replacement of the D.D. motor as shown above, proceed with the adjustment of the playback switching point.

Notes:

1. Be careful not to damage the upper drum or the video head.
2. Be sure that the Hall device and the D.D. stator assembly are not damaged by the D.D. rotor assembly or other parts.

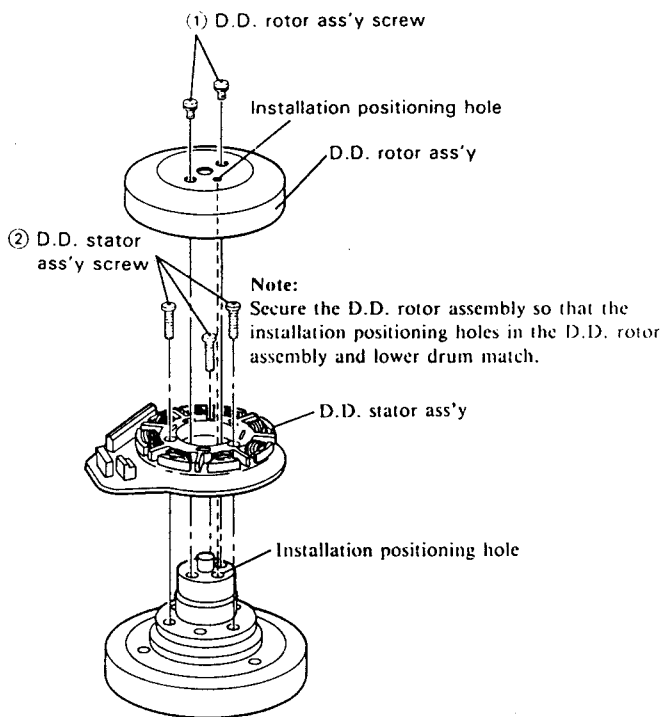

Figure 1-29.

REPLACEMENT OF THE CAPSTAN D.D. (DIRECT DRIVE) MOTOR

• Removal

1. Remove the FFC ① from the capstan D.D. motor control PWB ②.
2. Remove the three screws ③, and remove the capstan D.D. motor ④ from the main chassis.

• Reassembly

1. Mount the capstan motor on the main chassis while making sure not to allow the capstan shaft to hit the main chassis, and attach it with the three screws ③.
2. Insert the FFC ① into the capstan D.D. motor control PWB ②.

Notes:

1. After installing the capstan D.D. motor, be sure to rotate the capstan motor and check the movement.
2. Check and adjust the servo circuit.

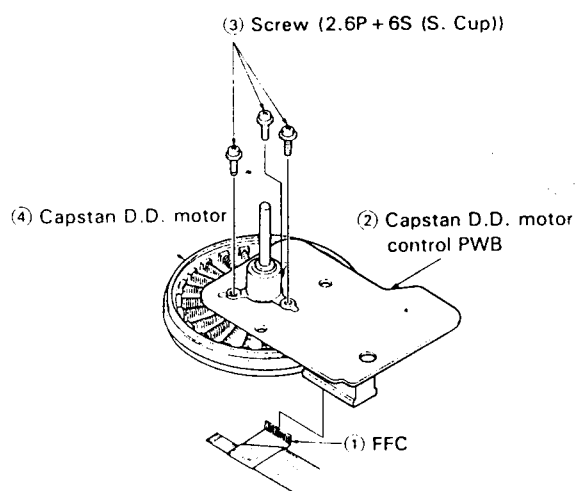

Figure 1-30.

REMOVAL AND REASSEMBLY OF THE LOADING GEAR BLOCK

• Removal

1. Remove the slow brake spring ① and slow brake lever ②.
2. Take out the E ring ⑧ first and then the loading relay gear ③.
3. Rotate the take-up loading gear ④, take-up loading arm assembly ⑤, supply loading gear ⑥ and supply loading arm assembly ⑦ slightly in the loading direction, and take them all out.
4. Finally remove the E ring ⑧ and relay gear drive lever ⑧.

• Reassembly

1. Take the reverse steps of the removal.
2. In reassembling, match the tally marks on the gears, as shown in Fig. 1-31

Note:

1. When reassembling, apply grease to the following points; all the gear teeth, all the gear shafts, and the cam groove of loading relay gear which the relay gear drive lever pin comes in.
2. Be careful not to deform the supply/take-up loading arms.
3. Be careful not to stain the felt of the slow brake.
4. Be also careful to keep the outer surface of the capstan D.D. motor ⑨ free from dust and dirt. (If stained, the MR (Magnet Resistor) element ⑩ might be damaged.)
5. Reshape the anti-fall hooks of the slow brake, supply/take-up loading gears as required. Avoid reshaping too much.

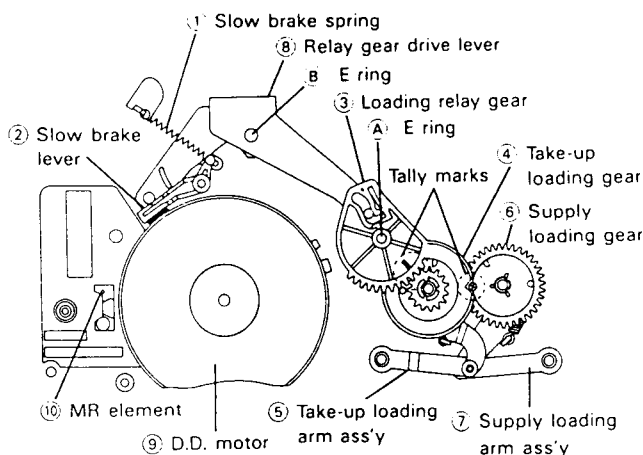

Figure 1-31.

REMOVAL AND REASSEMBLY OF LOADING BLOCK

• Removal

1. Remove the leads and the cassette loading belt from the loading block.
2. Unscrew the three screws ③, and pull up and remove the loading block.

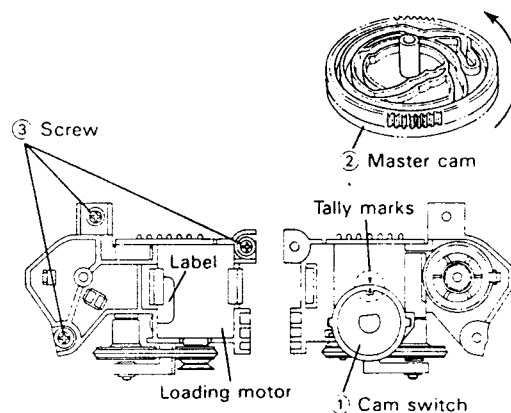

Figure 1-32.

• Reassembly

1. Turn the master cam ② all the way counter-clockwise.
2. Match the tally mark on the cam switch ① with the mating mark. Fit the loading block and the master cam with each other. Tighten up the three screws.
3. Finally connect the leads and apply the cassette loading belt.

Notes:

1. Be careful not to scratch the gear.
2. Be careful not to stain the belt. If dirty, clean it up.

REPLACEMENT OF LOADING MOTOR

• Removal

1. Remove the loading block.
2. Undo the loading belt.
3. Unsolder the leads from the loading motor ①.
4. Unlock the left and right catches of the cam switch ② off the loading block. Take out the loading block PWB ③.

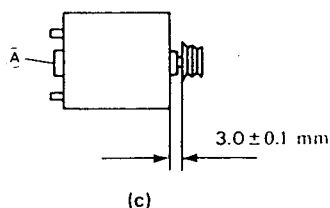
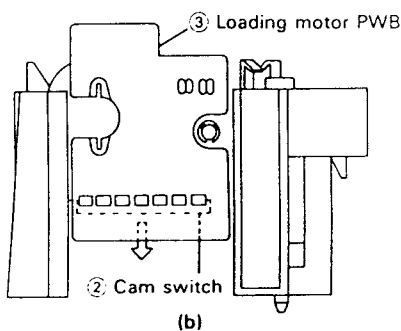
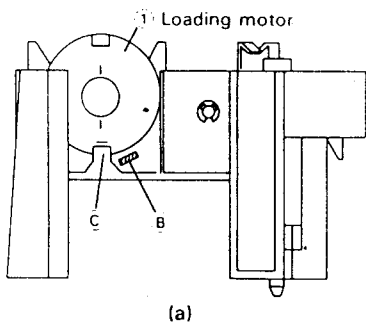

Note:

1. Press-fit the loading motor pulley to the dimension specified in Fig. 1-33(c).
2. Keep the pressure on the part ① (see above) less than 5 kg.

Figure 1-33.

5. Put the tip of a bladed screwdriver or the like into the opening ⑥ shown in Fig. 1-33 (a). Pry up the back end of the loading motor ① and take out the motor.

• Reassembly

1. Place the loading motor so that its label is visible as shown in Fig. 1-32.

Note:

Make sure that the screw hole at the motor shaft and the protuberance on the loading block are properly engaged and that the notch at the loading motor end and the part ⑦ of the loading block are also fitted together.

2. Set up the loading block PWB ③ and the cam switch ② in position.
3. Resolder the leads to the loading motor.
4. Finally place the loading block in position.

REPLACEMENT OF MASTER CAM

• Removal

1. Remove the loading block.
2. Remove the E ring ④ and then the half-loading reciprocating lever ①.

Note:

There is no need to take out the half-loading drive lever.

3. Remove the E ring ⑤ first and then the pinch roller lever ②.
4. Finally pull out the master cam ③ upward.

• Reassembly

1. Place the relay gear drive lever in the unloading state as shown in Fig. 1-31.
2. Set the relay shifter lever ④ to the main chassis; the shifter lever should be adjusted to the reverse guide spring hole in the main chassis. Then place the master cam so that the cut-off part of the boss ⑥ should face the direction of arrow → ⑦.
3. Place the half-loading reciprocating lever ① so that its cam follower comes in the outermost cam groove. Now attach the E ring ④.

Note:

Preferably hook the half-loading reciprocating spring ⑤ before attaching the lever. It is easier to set up.

4. Turn the master cam ③ somewhat clockwise until the pinch roller lever's cam follower comes into the master cam's groove ⑧. Then attach the E ring ⑤.
5. Rotate the master cam ③ by hand to make sure all the four levers (relay gear drive lever, relay shifter lever, half-loading reciprocating lever and pinch roller lever) are right in the cam grooves.
6. Finally set up the loading block.

Notes:

1. Be careful not to scratch the teeth and grooves of the master cam.
2. Before placing the loading block, be sure to rotate the master cam by hand to make sure the levers are right in their respective positions. Otherwise the master cam and the levers might get damaged when the motor starts.
3. Apply grease to the master cam's grooves and teeth.

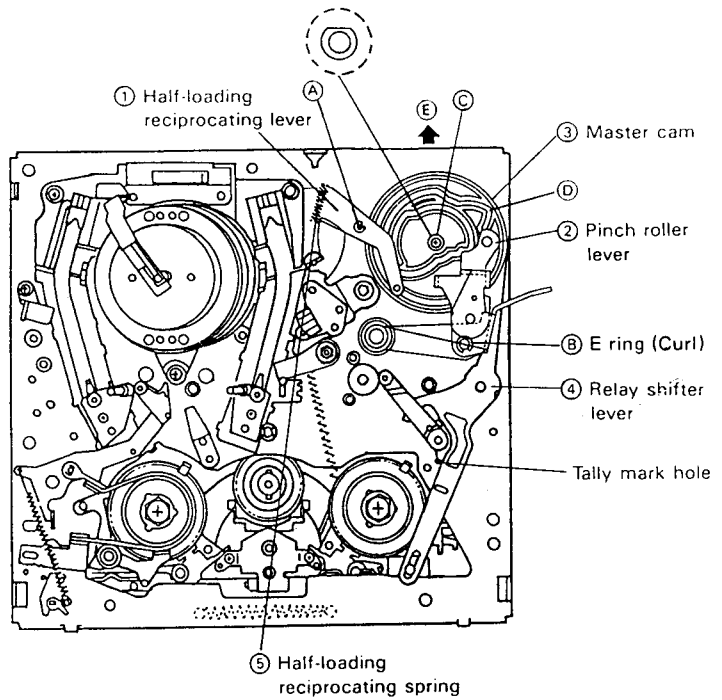

Figure 1-34.

ADJUSTMENT OF ELECTRICAL CIRCUITRY

Prior to the adjustment:

In most cases, necessity for electrical circuits will arise from replacement of mechanical parts including the video head. Before starting adjustment of electrical circuits, check that mechanical operation of the equipment is complete (the mechanism are adjusted completely).

If the equipment fails electrically, locate a defect or defects first of all using instruments. Then repair or replace parts and make adjustment by the procedures described below.

When required instruments are not available, do not move controls indiscriminately.

- Instruments
- Color monitor TV
- DC regulated power supply
- VTVM
- Oscilloscope
- Audio generator
- Color bar generator
- Alignment tape
- Frequency counter
- Blank video tape(VHS)
- Voltmeter

ADJUSTMENT OF MAIN (SERVO, SYSTEM CONTROL, TUNER) CIRCUIT

- Test points layout

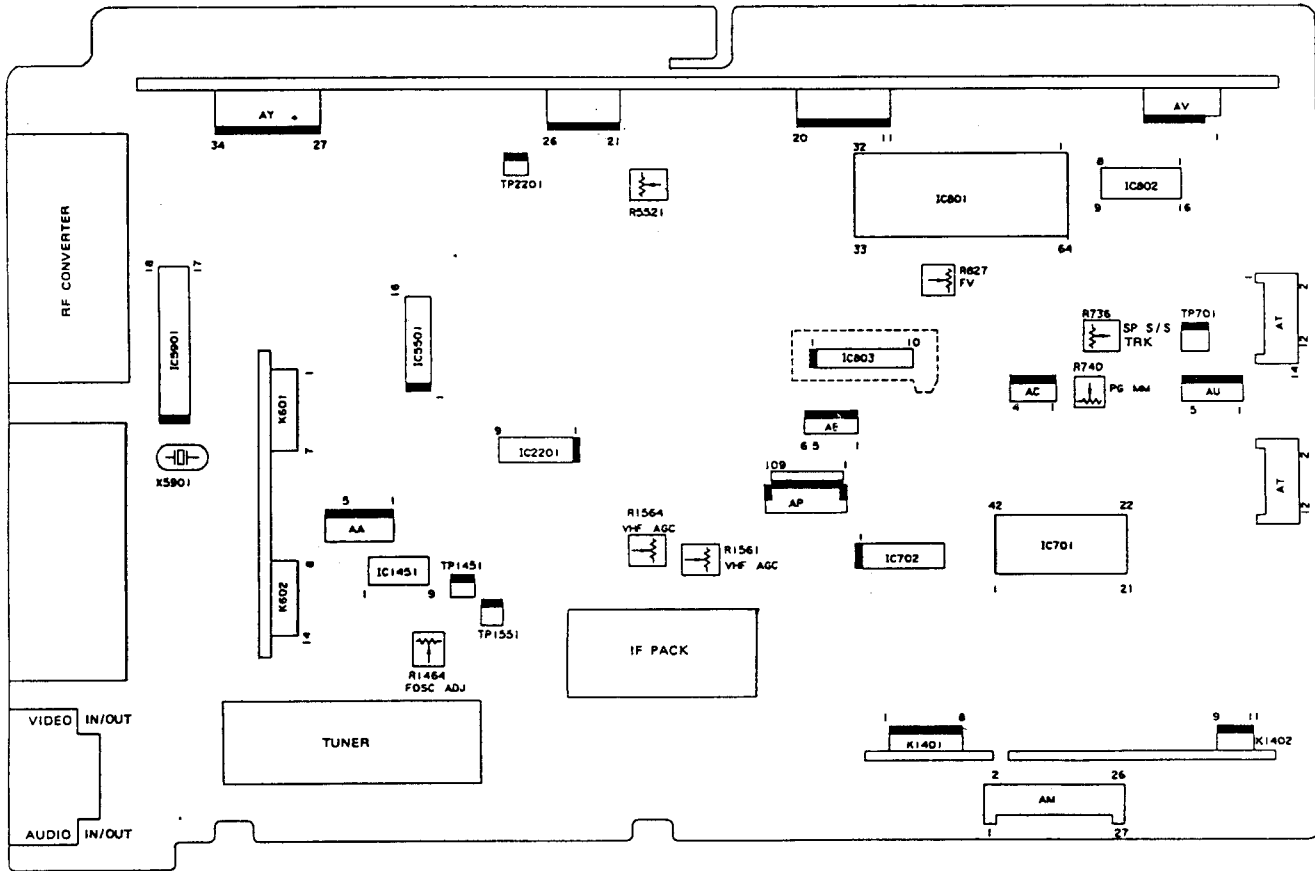

Figure 2-1. MAIN PWB

ADJUST

Adjustr

Measu
instru

Mode

Tape L

Test p

Adjus

Specif

1. Inser
- unit
- Set t
3. Adju
- that
- as sh

CH

(V

C

Adjust

Meas
instru

Mod

Inpu

Test

Adju

Spec

ADJUSTMENT OF SERVO CIRCUIT

Adjustment of playback switching point

Measuring instrument	Oscilloscope
Mode	Playback Tracking button at center
Tape used	Alignment tape (VROCPSV)
Test point	CH-1; TP701 CH-2; Video output terminal (CH-1 trigger slope switch at (+), Internal trigger at CH-1 side)
Adjusting point	R740(phase generator MM control)
Specification	$6.5 \pm 0.5H$

1. Insert the alignment tape (VROCPSV) and put the unit in the playback mode.

2. Set the tracking button to the center position.

3. Adjust R740 (phase generator MM control) so that the waveform on the oscilloscope screen be as shown in Fig. 2-2.

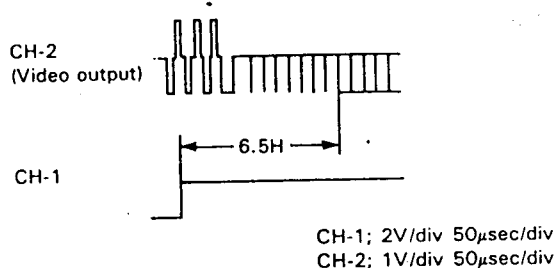

Figure 2-2.

1. Receive a commercial broadcast signal, or feed the video signal to the video input terminal (with the external input selector switch).
2. Set the record time switch to the SP position. Make recording and playback on the self-recording tape.
3. Press the slow button and play back the recorded portion in the slow mode.
4. Set the slow tracking button to the center position.
5. Observing the monitor screen, adjust the SP slow tracking preset control (R736) until the noise bar disappears from the screen.
6. Press the playback button to play back the tape. Then push the pause/still button to reproduce the recording in the still mode. Now make sure there is no noise on the screen. (Repeat this step three times or so.)

Adjustment of still picture vertical sync

Measuring instrument	Monitor TV
Mode	Still picture playback
Tape used	Self-recording tape
Test point	Monitor screen
Adjusting point	R828 (still picture vertical sync control)
Specification	No vertical jitter

1. Play back the tape self-recorded in the SP mode.
2. Press the pause/still button to reproduce the recording in the still mode.
3. Observing the monitor screen, adjust the still picture vertical sync control (R828) until the vertical jitter disappears from the screen.

Adjustment of SP slow tracking

Measuring instrument	Monitor TV
Mode	Record time switch at sp Position. Recording and playback on self-recording tape.
Input signal	Commercial broadcast or video signal (external input selector switch)
Test Point	Monitor screen
Adjusting point	R736 (SP slow tracking control)
Specification	No noise bar on the monitor TV screen

Precaution in adjusting the X-position

Measuring instrument	Oscilloscope
Mode	Playback
Tape used	Alignment tape(VROCPSV)
Test point	Pin ② of TP701 (tracking monitor output)
Adjusting point	_____
Specification	$T = 14.78 \pm 0.46$ msec.

Tracking monitor output (TP701)

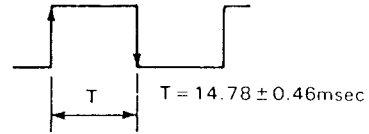

Figure 2-3.

1. Insert the alignment tape (VROCPSV) and put the unit in the palyback mode.
2. Set the tracking button to the center position.
3. Make sure that the "H" level tine (T) at pin ② of TP701 (tracking monitor output) is 14.78 ± 0.46 msec. Now go to the X-position adjustment.

ADJUSTMENT OF Y/C CIRCUIT

- Test point layout

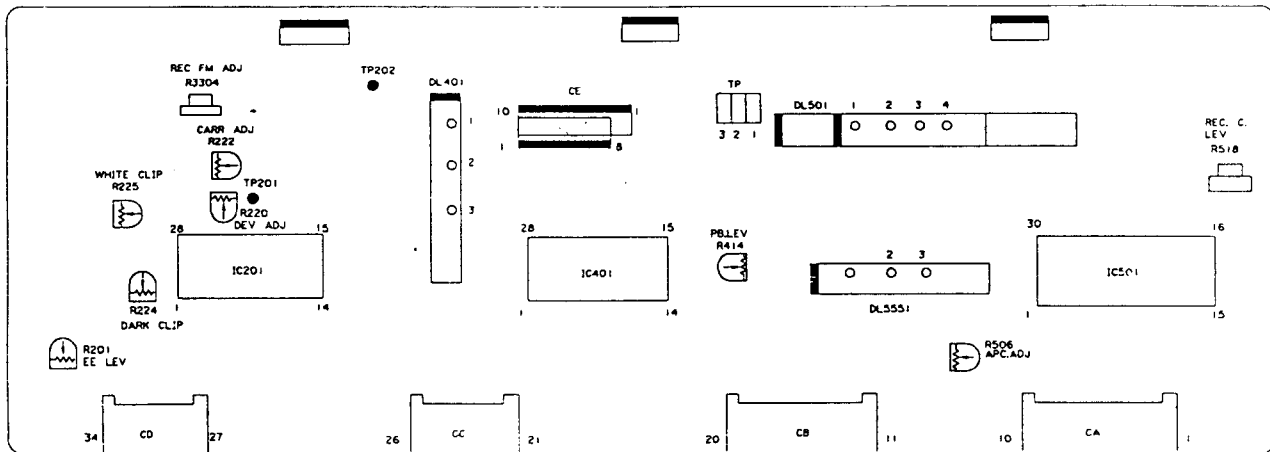

Figure 2-4. Y/C PWB

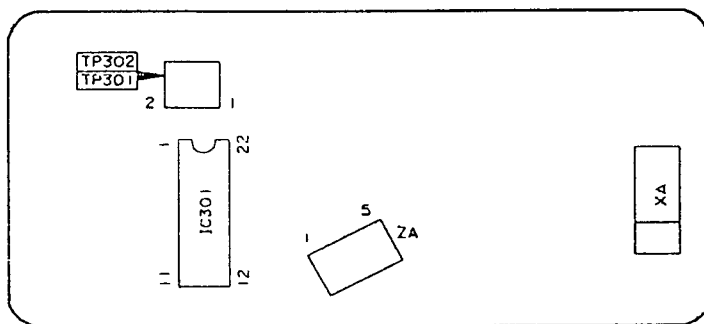

Figure 2-5.

■ AI
 Adju
 Me
 inst
 Mo
 Inp
 Tes
 Ad
 Sp
 Note
 The
 with
 1. Se
 2. Fu
 th
 a
 te
 (f
 F
 A.
 V
 ir
 V
 Ir
 T
 A
 F
 S
 No
 Ca
 be
 or
 of

■ ADJUSTMENT OF Y/C RECORDING CIRCUIT

Adjustment of EE level

Measuring instrument	Oscilloscope
Mode	SP recording
Input signal	Standard color bar (stair-case waveform)
Test point	Video output terminal
Adjusting point	R201 (EE level control)
Specification	1.0 ± 0.05 Vp-p

Note:

The video output terminal should be terminated with a 75-ohm impedance.

1. Set the unit to the SP record mode.
2. Feed the color bar signal(stair-case waveform)to the video input terminal. Observing the voltage across the terminal resistor of the video output terminal on the oscilloscope screen, adjust R201 (EE level control) to obtain the value indicated in Fig. 2-6.

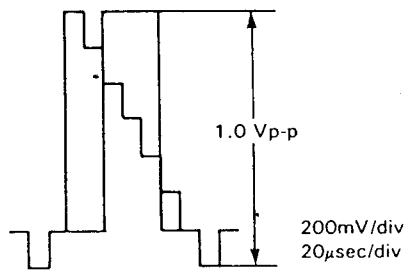

Figure 2-6.

Adjustment of FM 3.8 MHz and 4.8 MHz

Measuring instrument	Frequency counter	Oscilloscope
Mode	Recording	Self-recording / playback
Input signal	External input (no signal)	Standard color bar (stair-case waveform)
Test point	Pin(28) of IC201	Video signal
Adjusting point	R222 (FM carrier control)	R220 (deviation control)
Specification	3.8 MHz	1.0 ± 0.05 Vp-p

Note. 1:

Carry out this adjustment only when IC201 has been replaced or when the carrier setting (3.8 MHz) or the deviation (4.8 MHz) is found apparently out of specification.

Make this adjustment after the EE level has been completely adjusted.

Note. 2:

The video output terminal should be terminated with a 75-ohm impedance.

1. First make sure that the EE level playback video signal is at the specified level.
2. Place the unit in the record mode and get it ready for external input.

Note:

Do not connect anything to the external input terminal.

3. Hook up the frequency counter to pin 28 of IC201. Adjust R222 (FM carrier control) so that the counter reading be 3.8 MHz.

Note:

Make sure the white and dark clip controls are not now applied to the waveform.

4. Feed the color bar signal (stair-case waveform) and make self-recording and playback.
5. Observe the video output terminal voltage (across the terminal resistor) on the oscilloscope screen. If the playback video signal level is below 1.0 Vp-p, turn R220 (deviation control) clockwise. If above 1.0 Vp-p, turn the control counterclockwise. Now make self-recording and playback again.
6. Repeat the above step 5 to finally get the playback video signal level at 1.0 ± 0.05 Vp-p, as shown in Fig. 2-6.

Adjustment of white clip

Measuring instrument	Oscilloscope
Mode	Recording
Input signal	Standard color bar (stair-case waveform)
Test point	TP201
Adjusting point	R225 (white clip control)
Specification	80 + 0 % - 4 %

1. Place the unit to the record mode.
2. Feed the color bar (stair-case waveform) signal.
3. Observing the output at TP201, adjust R225 (white clip control) so that the white peak overshoot be 80% (tolerance: + 0%, - 4%)

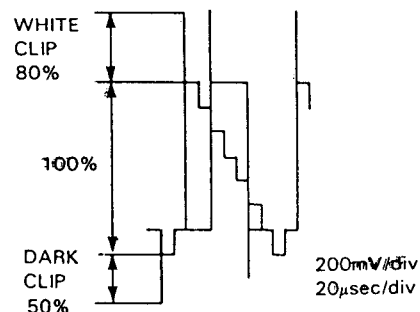

Figure 2-7.

Adjustment of dark clip

Measuring instrument	Oscilloscope
Mode	Recording
Input signal	Standard color bar (stair-case waveform)
Test point	TP201
Adjusting point	R224 (dark clip control)
Specification	$50 \pm 4\%$

1. Place the unit to the recording mode.
2. Feed the color bar (stair-case waveform) signal.
3. Observing the output at TP201, adjust R224 (dark clip control) so that the dark peak overshoot be $50 \pm 4\%$. (See fig. 2-7.)

Adjustment of recording current

Measuring instrument	Oscilloscope	
Mode	Recording	
Input signal	Standard color bar (stair-case waveform)	
Test point	TP301 (GND at TP302) External trigger (video output terminal)	
Adjusting point	R3304 (recording FM control)	R518 (recording chroma control)
Specification	Sync tip level $140 \pm 10mVp-p$	Red level $24 \pm 1mVp-p$

Note:
TP301 and TP302 are located on the head amp PWB.

1. Place the unit to the record mode.
2. Feed the color bar (stair-case waveform) signal.
3. Observing the waveform on the oscilloscope screen (external trigger at video output terminal), take the following steps.
 - a) Connect the oscilloscope's GND and SIG leads to TP302 and TP301, respectively.
 - b) Turn R3304 (recording FM control) to minimum.
 - c) Adjust R518 (recording chroma control) to that the red level be $24 \pm 1mVp-p$ as shown in Fig.2-8.
4. Adjust R3304 (recording FM control) so that the sync tip be $140 \pm 10mVp-p$ as shown in Fig.2-9.

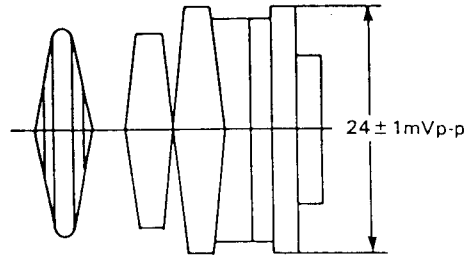

Figure 2-8.

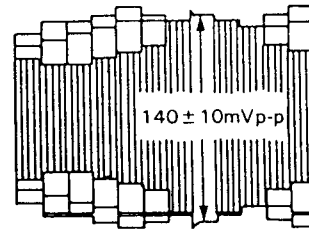

Figure 2-9.

■ ADJUSTMENT OF Y/C PLAYBACK CIRCUIT

Adjustment of playback video signal level

Measuring instrument	Oscilloscope
Mode	Playback
Tape used	Alignment tape (stair-case waveform)
Test point	TP201
Adjusting point	R414 (playback level control)
Specification	$1.0 \pm 0.05Vp-p$

Note:
The video output terminal should be terminated with a 75-ohm impedance.

1. Insert the alignment tape (stair-case waveform) and place the unit to the playback mode.
2. Hook up the oscilloscope to the video output terminal. Adjust R414 (playback level control) so that the on-screen waveform be $1.0 \pm 0.05Vp-p$.

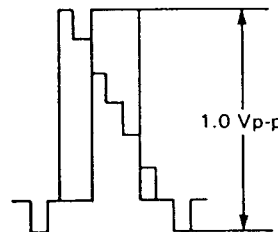

Figure 2-10.

Adjustment of APC

Measuring instrument	Frequency counter
Mode	Playback
Tape used	Alignment tape (VROCPSV)
Test point	Pin ⑦ of CA connector
Adjusting point	R506
Specification	4.433619MHz ± 50Hz

1. Insert the alignment tape (VROCPSV) and place the unit to the playback mode.
2. Connect the frequency counter to pin ⑦ of CA connector. Adjust R506 (APC control) so that the counter reading be 4.433619MHz ± 50Hz.

ADJUSTMENT OF AUDIO CIRCUIT

Test point layout

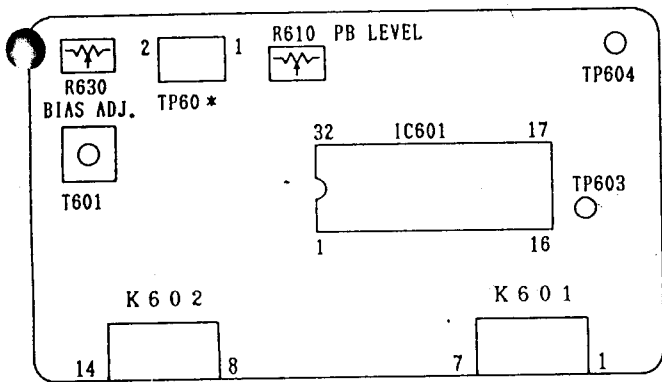

Figure 2-11. AUDIO PWB

Checking of erase voltage and oscillation frequency

Measuring instrument	Oscilloscope
Mode	Recording
Input signal	_____
Test point	Both ends of the full-erase head
Adjusting point	_____
Specification	Erase voltage; Over 40 Vp-p Oscillation frequency; 70 ± 7kHz

1. Place the unit to the record mode.
2. Hook up the oscilloscope to both ends of the full-erase head.
3. Make sure the erase voltage is over 40 Vp-p.
4. Be sure that the oscillation frequency is 70 ± 7kHz.

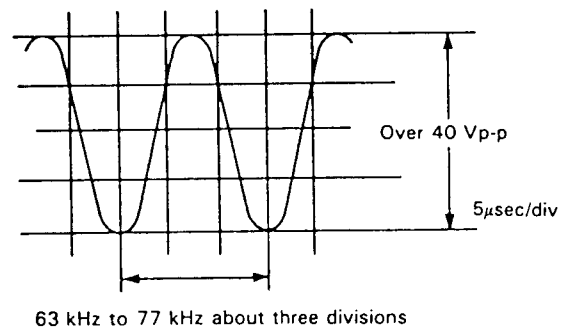

Figure 2-12.

Adjustment of playback level

Measuring instrument	VTVM
Mode	Playback
Input signal	Alignment tape (VROCPSV) (1-kHz level control signal)
Test point	Audio output terminal
Adjusting point	R610 (playback level control)
Specification	-9 ± 0.5dBm

1. Play back the alignment tape (1-kHz level control signal).
2. Hook up the VTVM to the audio output terminal.
3. Adjust R610 (playback level control) so that the output level be -9 ± 0.5dBm.

Adjustment of bias current

Measuring instrument	VTVM
Mode	Recording
Input signal	_____
Test point	TP601 (SIG), TP602 (GND)
Adjusting point	R630 (bias current control)
Specification	260 ± 10 µA

1. Place the unit to the record mode.
2. Connect the VTVM to TP601 (SIG) and TP602 (GND).
3. Adjust R630 (bias current control) so that the bias current be 260 ± 10 µA (2.6 ± 0.1mV).

Checking of recording level

Measuring instrument	VTVM
Mode	Self-recording / playback
Input signal	1 kHz / -8 dBm
Test point	Audio output terminal
Adjusting point	_____
Specification	-5 ± 3 dBm

1. Feed 1kHz, -8 dBm signal to the audio input terminal. Make self-recording and playback of the signal.
2. Make sure the output at the audio output terminal is -5 ± 3 dBm.
3. If out of spec, readjust the playback level and the bias current.

ADJUSTMENT OF IF CIRCUIT

Adjustment of RF AGC

Measuring instrument	Oscilloscope
Mode	_____
Input signal	Color bar signal
Test point	Video output terminal
Adjusting point	VR001 (RF AGC)
Specification	_____

1. Receive the color bar signal (input field strength: 80 dBμ).
2. Observe the video output terminal waveform on the oscilloscope. Adjust VR001 (RF AGC) in the IF pack until the noise disappears from the oscilloscope screen and the waveform nearly comes into sync.



Figure 2-13.

Adjustment of AFT

Measuring instrument	Oscilloscope Signal generator
Mode	_____
Input signal	PIF frequency uniwave VR6448/57 : 39.5 MHz. VR6448/67 : 38.9 MHz. Colour bar signal (70dBμ)
Test point	Video output terminal
Adjusting point	T002 (AFT coil)
Specification	_____

1. Receive the color bar signal (input field strength: 70 dB μ).
2. First set the BAND SELECTOR switch to VHF or UHF position.
Using the signal generator, feed the PIF frequency signal (sine wave) to the tuner IF output terminal. Use the (-) and (+) keys so that the video output terminal waveform be minimum.
3. Set the band selector switch NORMAL position.
4. Using the signal generator, feed the PIF frequency signal (sine wave) to the tuner IF output terminal. (Adjust the attenuator to attenuate the input signal down to an appropriate level).
5. Adjust T002 (AFT coil) in the IF pack so that the video output terminal waveform be minimum.

WA
SYST



TP701
Head s
2V/Div
5msec/
IC701
Drum f
1V/Div
5msec



IC701
Horiz
1V/D
5msec



TP2
Hor
1V/
20μ
- f



TP
PI
50
5
TP
H
5
5
-

WAVE FORMS

SYSTEM CONTROL, SERVO, IF PWBs

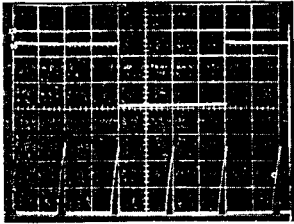

TP701 (1) pin
Head switching pulse
2V/Division
5msec/Division

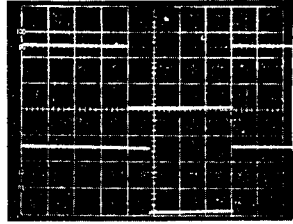

TP701 (1) pin
Head switching pulse
2V/Division
5msec/Division

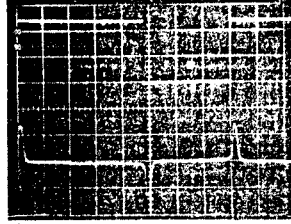

TP701 (3) pin
Playback control pulse
2V/Division
5msec/Division

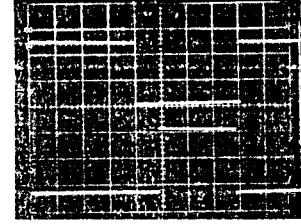

TP701 (11) pin
Head switching pulse
2V/Division
5msec/Division

IC701 (29) pin
Drum pulse generator
1V/Division
5msec/Division

TP701 (2) pin
Tracking MM pulse
2V/Division
5msec/Division
— Record mode —

IC701 (4) pin
Playback control signal
500mV/Division
5msec/Division

TP701 (2) pin
Tracking MM pulse
2V/Division
5msec/Division
— Playback mode —

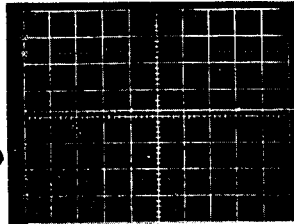

IC701 (30) pin
Horizontal sync pulse
1V/Division
5msec/Division

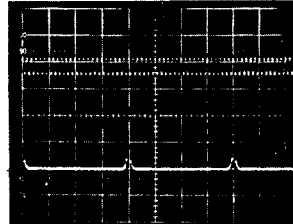

Socket AM (9) pin
Drum frequency generator signal
50mV/Division
10msec/Division

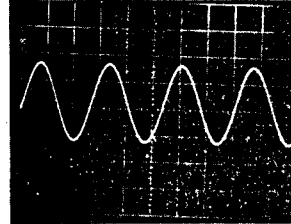

Socket AM (15) pin
Capstan frequency generator signal
500mV/Division
0.5msec/Division

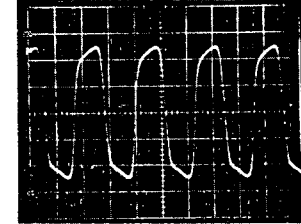

Plug AV (8) pin
4.43MHz oscillation signal
200mV/Division
0.1µsec/Division

Socket AM (12) pin
Drum phase generator pulse
200mV/Division
10mV/Division

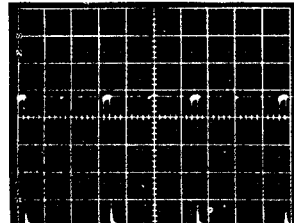

TP2201
Horizontal sync pulse
1V/Division
20µsec/Division
— Record mode —

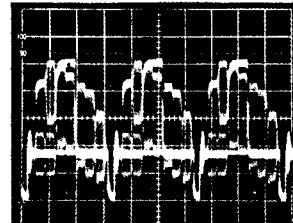

Video output terminal
(Video output is shorted with a 75 ohm resistor.)
Video signal
200mV/Division
20µsec/Division
— Playback mode —

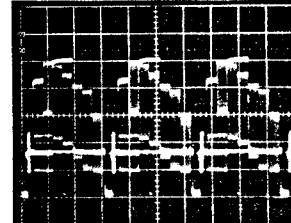

Video output terminal (E-E level)
(Video output is shorted with a 75 ohm resistor.)
Video signal
200mV/Division
20µsec/Division
— Record mode —

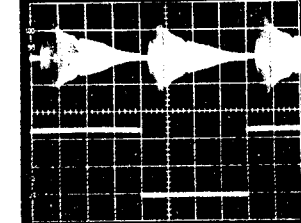

TP1
Playback preamp. signal
200mV/Division
5msec/Division

TP2
Head switching pulse
2V/Division
5msec/Division
— Playback mode —
(Sweep tape)

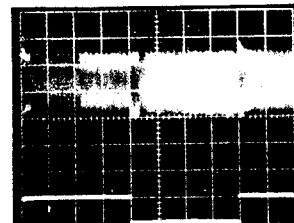

TP1
Playback preamp. signal
50mV/Division
5msec/Division

TP2
Head switching pulse
5V/Division
5msec/Division
— Playback mode —
(color bar)

Y/C, AUDIO PWB

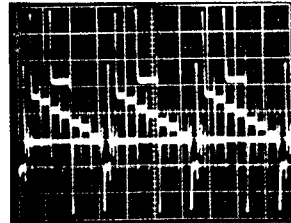

TP201
White/Dark clip signal
100mV/Division
20µsec/Division
— Record mode —

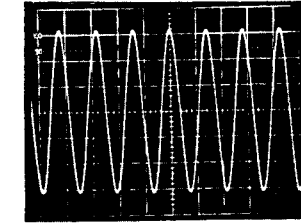

K602 (9), (11) pin
(Between audio erase head and ground)
10V/Division
10µsec/Division
— Record mode —

SCHEMATIC DIAGRAM

IMPORTANT SAFETY NOTICE:
 BE SURE TO USE GENUINE PARTS FOR SECURING THE SAFETY AND RELIABILITY OF THE SET. PARTS MARKED WITH " Δ " AND PARTS SHADED (IN BLACK) ARE ESPECIALLY IMPORTANT FOR MAINTAINING THE SAFETY AND PROTECTING ABILITY OF THE SET.
 BE SURE TO REPLACE THEM WITH PARTS OF SPECIFIED PART NUMBER.

SAFETY NOTES:

1. DISCONNECT THE AC PLUG FROM THE AC OUTLET BEFORE REPLACING PARTS.
2. SEMICONDUCTOR HEAT SINKS SHOULD BE REGARDED AS POTENTIAL SHOCK HAZARDS WHEN THE CHASSIS IS OPERATING.

NOTES:

1. The unit of resistance "ohm" is omitted (k = 1000 ohm, M = 1 Meg ohm).
2. All resistors are 1/8 watt, unless otherwise noted.
3. The unit of capacitance "F" is omitted (μ = μ F, p = μ μ F).

VOLTAGE MEASUREMENT CONDITIONS:

1. DC voltages are measured between points indicated and chassis ground by VTVM, with AC220V/50Hz supplied to unit and all controls are set to normal viewing picture unless otherwise noted.
2. Voltages are measured with 10000 μ V B & W or colour signal.

WAVEFORM MEASUREMENT CONDITIONS:
 10000 μ V 87.5 percent modulated colour bar signal is fed into tuner.

CAUTION:
 This circuit diagram is original one. Therefore there may be a slight difference from yours.

MANUFACT	MECH
1	CASSET
2	GND
3	START
4	AT 5V
5	END SI
	NC
1	DRUM
2	DRUM
3	DRUM
4	DRUM
5	DRUM
6	DRUM
7	PC 5V
8	CAPST
9	CASST
10	2.5V
11	CAPST
12	CLPKE
13	CAPST
14	MGND
15	GND
	NC
1	GND
	AT 5
3	TU
4	BRA
	BRA

MP	A/C
5	CTL
	GND
6	CTL

MG	LOAD
1	LD
2	LD
3	CA
4	BN
5	DE

MB	D
1	DB
2	PK
3	DP
4	CR

OVERALL WIRING DIAGRAM

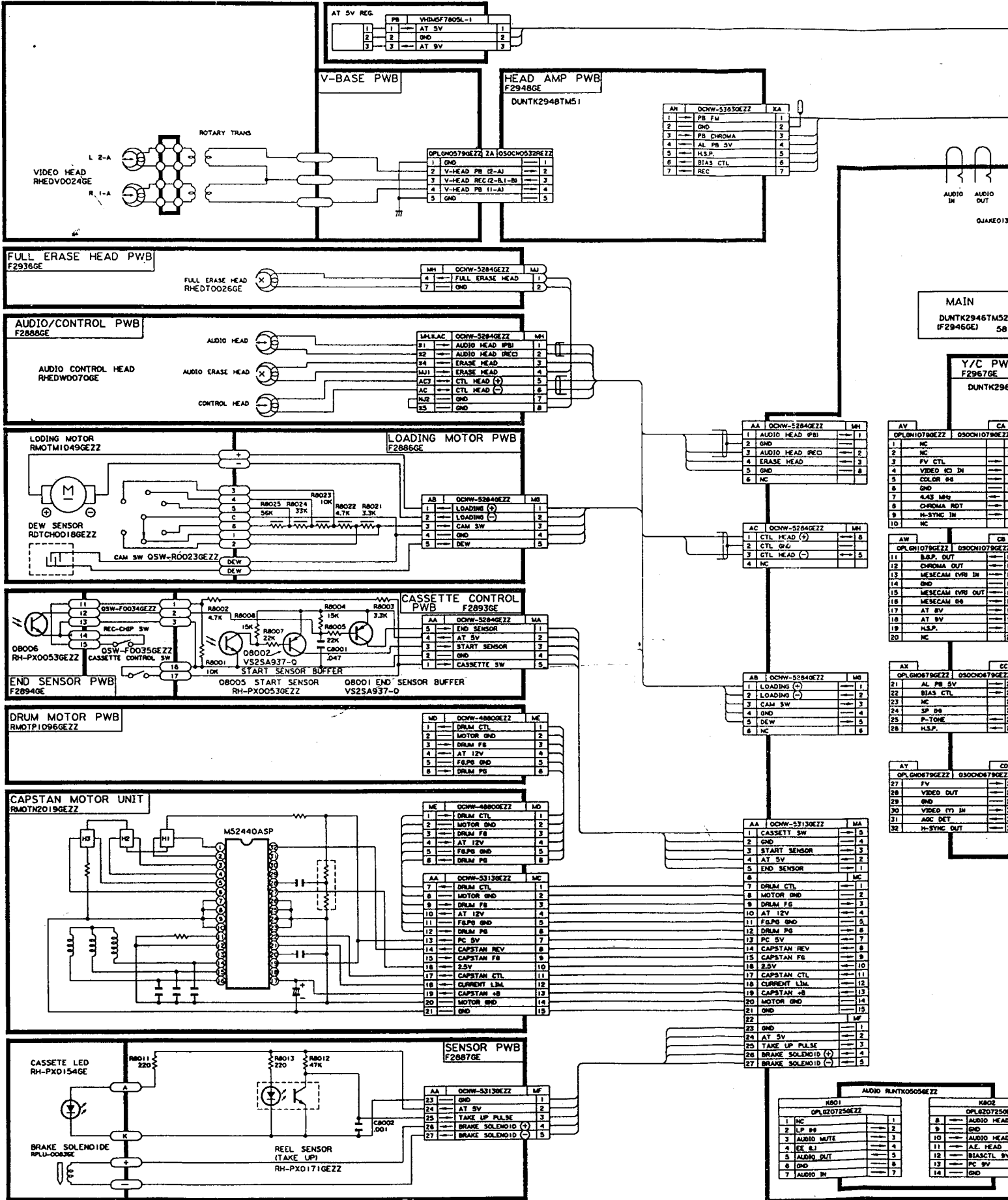

PC	AC CORD	N
1	AC 220V	N
2	NO PIN	
3	AC 220V	L

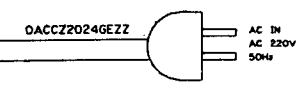

POWER UNIT
 RDNT0317GEZZ (67)
 RDNT0316GEZZ (73)

PC	AC CORD	N
1	AC 220V	N
2	NO PIN	
3	AC 220V	L

PA	AP
1 M 12V	1
2 M GND	2
3 AT 9V	3
4 AT 5V	4
5 AT 45V	5
6 AC 40V	6
7 GND	7
8 AC	8
9 AC	9

HA	AU
1 GND	1
2 PC 5V	2
3 GND	3
4 COLOUR H	4

TA	AG
1 AC 3.9V	1
2 AC 3.9V	2
3 GND	3
4 AT -30V	4
5 AC PULSE	5
6 AT 5V	6

TB	AS
1 VT	1
2 APT MUTE	2
3 B 0	3
4 B 1	4
5 GND	5
6 COUNTER RESET	6
7 S.T. READY	7
8 T.S. CLOCK	8
9 T.S. DATA	9
10 S.T. DATA	10
11 COUNTER PULSE	11
12 V TUNER 00	12
13 A TUNER 00	13

OPERATE
 DUNT02979E50

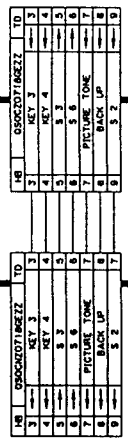

TIMER
 DUNT02978E50 (67)
 DUNT02978E52 (73)

XA	AN
1 PB FM	1
2 GND	2
3 PB CHROMA	3
4 AL PB 5V	4
5 H.S.P.	5
6 BIAS CTL	6
7 REC	7

XA	AN
1 VIDEO IN	1
2 AUDIO OUT	2
3 MOD 5V	3
4 NC	4
5 AT 5V	5

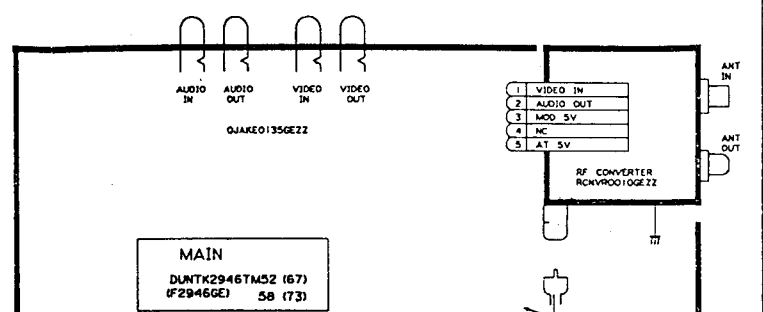

Y/C PWB
 F2967GE
 DUNT02967TM50

AV	CA
1 OPL01078GEZZ	0500N1078GEZZ
1 NC	1
2 NC	2
3 FV CTL	3
4 VIDEO RG IN	4
5 COLOR 00	5
6 GND	6
7 4.43 MHz	7
8 CHROMA ROT	8
9 N-SYNC IN	9
10 NC	10

AW	CB
1 OPL01078GEZZ	0500N1078GEZZ
11 B.S.P. OUT	11
12 CHROMA OUT	12
13 MESECAM (VR) IN	13
14 GND	14
15 MESECAM (VR) OUT	15
16 MESECAM 00	16
17 AT 5V	17
18 AT 5V	18
19 H.S.P.	19
20 NC	20

AX	CC
1 OPL00678GEZZ	0500N0678GEZZ
21 AL PB 5V	21
22 BIAS CTL	22
23 NC	23
24 SP 00	24
25 P-TONE	25
26 H.S.P.	26

AY	CD
1 OPL00678GEZZ	0500N0678GEZZ
27 FV	27
28 VIDEO OUT	28
29 GND	29
30 VIDEO IT3 IN	30
31 ASC DET	31
32 N-SYNC OUT	32

AA	MA
1 OCNW-5284GEZZ	0500N5284GEZZ
1 AUDIO HEAD (PB)	1
2 GND	2
3 AUDIO HEAD (REC)	3
4 ERASE HEAD	4
5 GND	5
6 NC	6



AC	MB
1 OCNW-5284GEZZ	0500N5284GEZZ
1 CTL HEAD (+)	1
2 CTL GND	2
3 CTL HEAD (-)	3
4 NC	4

AB	MC
1 OCNW-5284GEZZ	0500N5284GEZZ
1 LOADING (+)	1
2 LOADING (-)	2
3 CAM SW	3
4 GND	4
5 DEW	5
6 NC	6

AA	MA
1 OCNW-5313GEZZ	0500N5313GEZZ
1 CASSETT SW	1
2 GND	2
3 START SENSOR	3
4 AT 5V	4
5 END SENSOR	5
6 NC	6
7 DRUM CTL	7
8 MOTOR GND	8
9 DRUM FG	9
10 AT 12V	10
11 FLSP GND	11
12 DRUM PG	12
13 PC 5V	13
14 CAPSTAN REV	14
15 CAPSTAN FG	15
16 2.5V	16
17 CAPSTAN CTL	17
18 CURRENT LIM	18
19 CAPSTAN 00	19
20 MOTOR GND	20
21 GND	21
22 GND	22
23 GND	23
24 AT 5V	24
25 TAKE UP PULSE	25
26 BRAKE SOLENOID (+)	26
27 BRAKE SOLENOID (-)	27

KA01	KB02
1 OPL020725GEZZ	0500N020725GEZZ
1 NC	1
2 LP 00	2
3 AUDIO MUTE	3
4 EC 01	4
5 AUDIO OUT	5
6 GND	6
7 AUDIO IN	7
8	8
9	9
10	10
11	11
12	12
13	13
14	14

SERVO, SYSTEM CONTROL IF TUNER CIRCUIT DIAGRAM (MAIN 1)

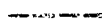
 Drum Control signal
 Drum frequency reference signal
 Drum phase reference signal

MAIN/CAF	MEGA	AM
1	CASSETTE SW	1 (5)
2	GND	2
3	START SENSOR	3 (57)
4	AT 5V	4
5	END SENSOR	5 (56)
6	NC	6
7	DRUM CTL	7
8	DRUM GND	8
9	DRUM FG	9
10	DRUM 12V	10
11	DRUM FGPG GND	11
12	DRUM PG	12
13	PC 5V	13
14	CAPSTAN REV 9V	14
15	CAPSTAN FG	15
16	2.5V	16
17	CAPSTAN CTL	17
18	CURRENT LMT	18
19	CAPSTAN 12V	19
20	MUND	20
21	GND	21
22	NC	22
23	GND	23
24	AT 5V	24
25	TU REEL PULSE	25
26	BRAKE SOLENOID	26
27	BRAKE SOLENOID	27

MPH	A/C HEAD	AC
5	CTL HEAD ⊕	1
	GND	2
6	CTL HEAD ⊖	3

MB	LOADING M/SENSOR	AB
1	LOADING M ⊕	1
2	LOADING M ⊖	2
3	CAM SW	3 (5)
4	GND	4
5	DEW SENSOR	5

MB	OPERATION	AU
1	GND	
2	PC 5V	
3	GND	
4	COLOUR 9V	(1)

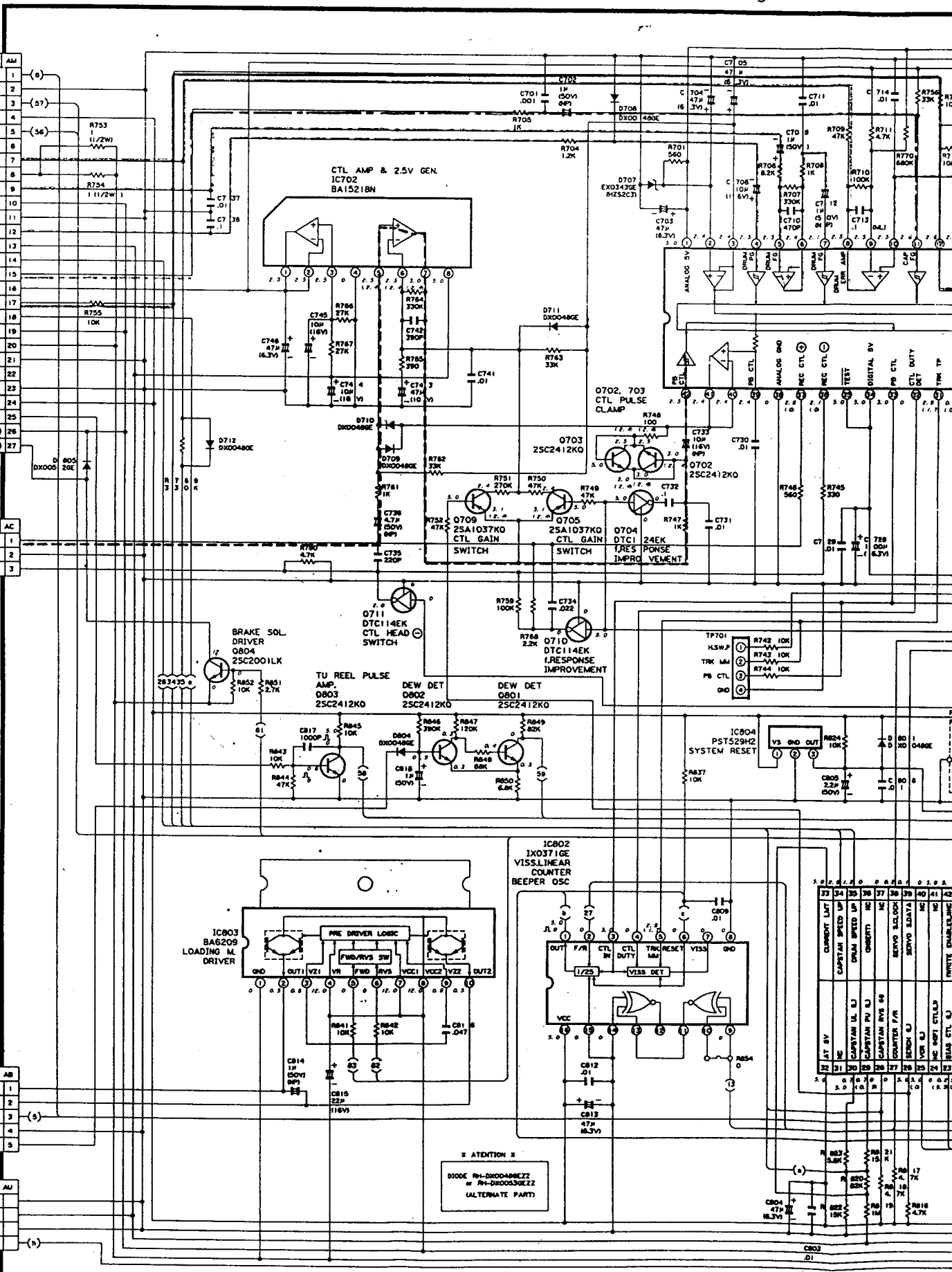

ATTENTION
 DIODE R4-DX0048E22
 w/ R4-DX0030E22
 (ALTERNATE PART)

Original
Reference signal
Reference signal

Capstan Control signal
Capstan frequency reference signal
Capstan phase reference signal

Record reference signal

(F2946GE)

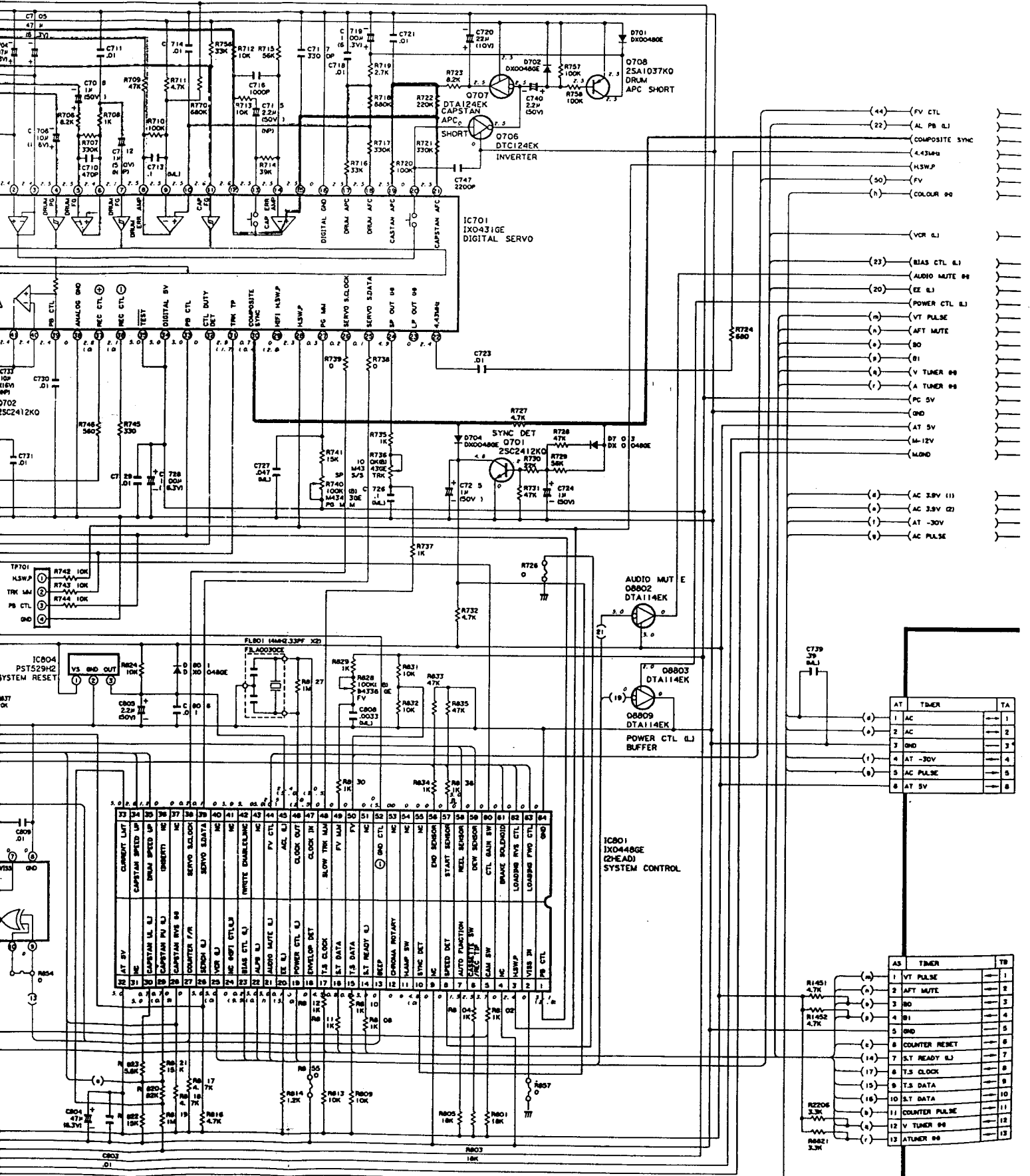

- (44) FV CTL
- (22) AL PB LJ
- COMPOSITE SYNC
- (4.43MHz)
- HSWP
- (30) FV
- (8) COLOUR 00
- VCR LJ
- (23) BIAS CTL LJ
- AUDIO MUTE 00
- (20) EE LJ
- POWER CTL LJ
- (8) VT PULSE
- (8) AFT MUTE
- (8) BO
- (8) B1
- (8) V TUNER 00
- (8) A TUNER 00
- (8) PC 5V
- (8) GND
- (8) AT 5V
- (8) M-12V
- (8) M-0V
- (8) (AC 3.8V (1))
- (8) (AC 3.8V (2))
- (8) AT -30V
- (8) AC PULSE

AT	TIMER	TA
(8)	1 AC	1
(8)	2 AC	2
(8)	3 GND	3
(8)	4 AT -30V	4
(8)	5 AC PULSE	5
(8)	8 AT 5V	8

AS	TIMER	TS
(8)	1 VT PULSE	1
(8)	2 AFT MUTE	2
(8)	3 BO	3
(8)	4 B1	4
(8)	5 GND	5
(8)	6 COUNTER RESET	6
(8)	7 ST READY LJ	7
(8)	8 TS CLOCK	8
(8)	9 TS DATA	9
(8)	10 ST DATA	10
(8)	11 COUNTER PULSE	11
(8)	12 V TUNER 00	12
(8)	13 ATUNER 00	13

SERVO, SYSTEM CONTROL IF TUNER CIRCUIT DIAGRAM (MAIN 2)

Record Luminance signal
Record Chrominance signal
Video E.F.F. signal

Au
Au
Au

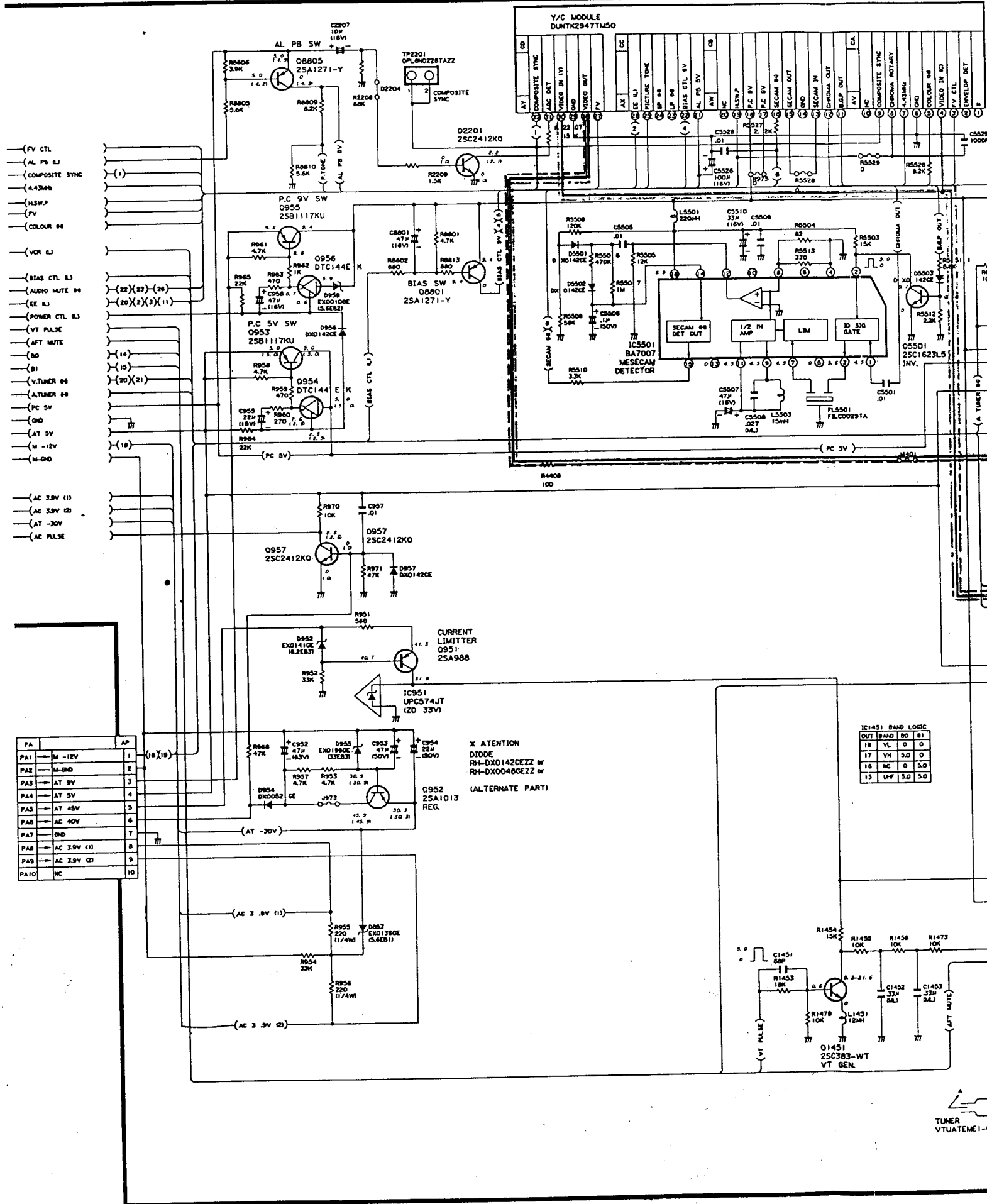

Record Luminance signal
 Record Chrominance signal
 Record E-E signal

———— Audio Record signal
 - - - - Audio Playback signal
 - · - · Audio E-E signal
 ———— Playback Luminance signal
 - - - - Playback Chrominance signal

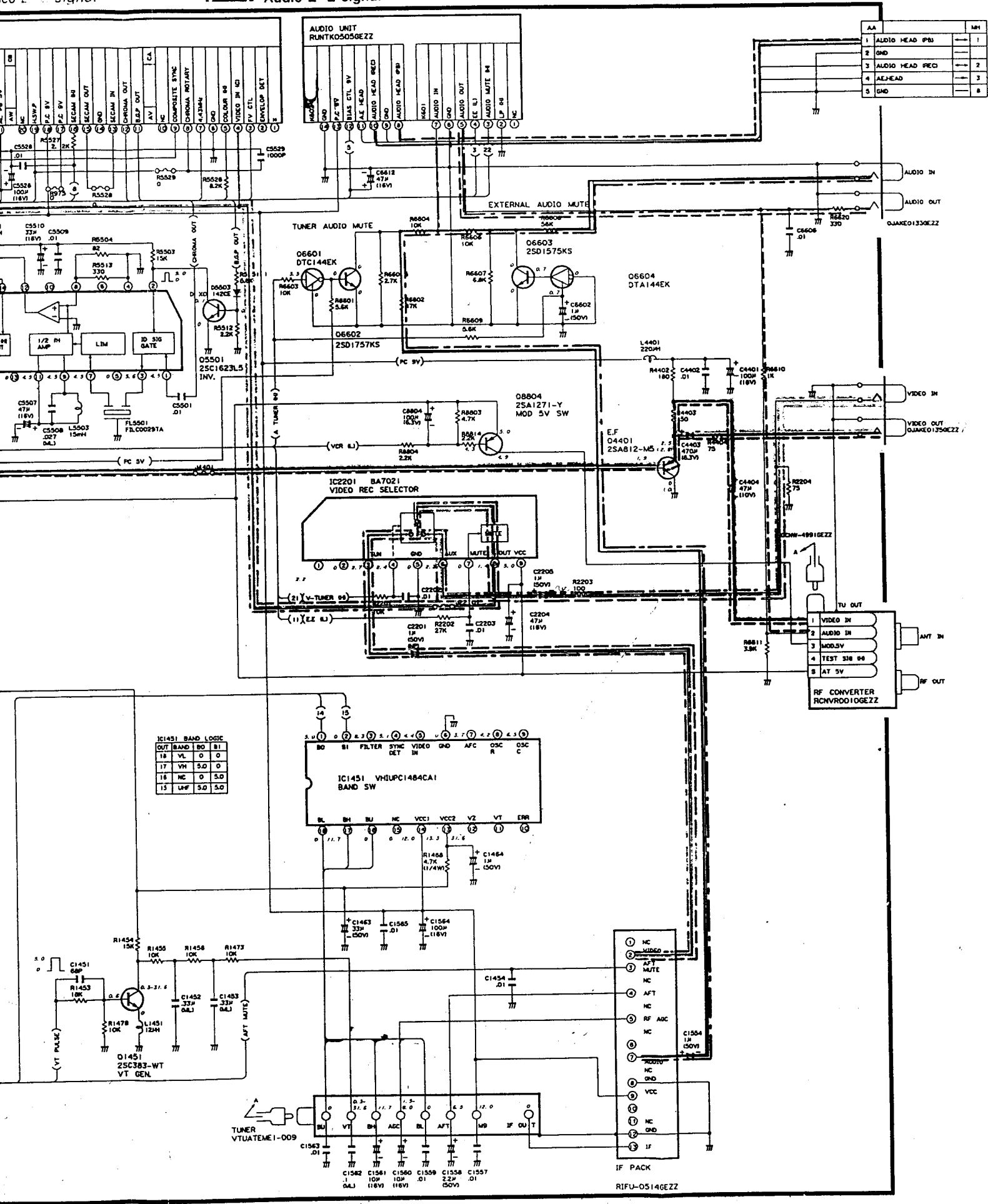

LUMINANCE CHROMINANCE CIRCUIT DIAGRAM

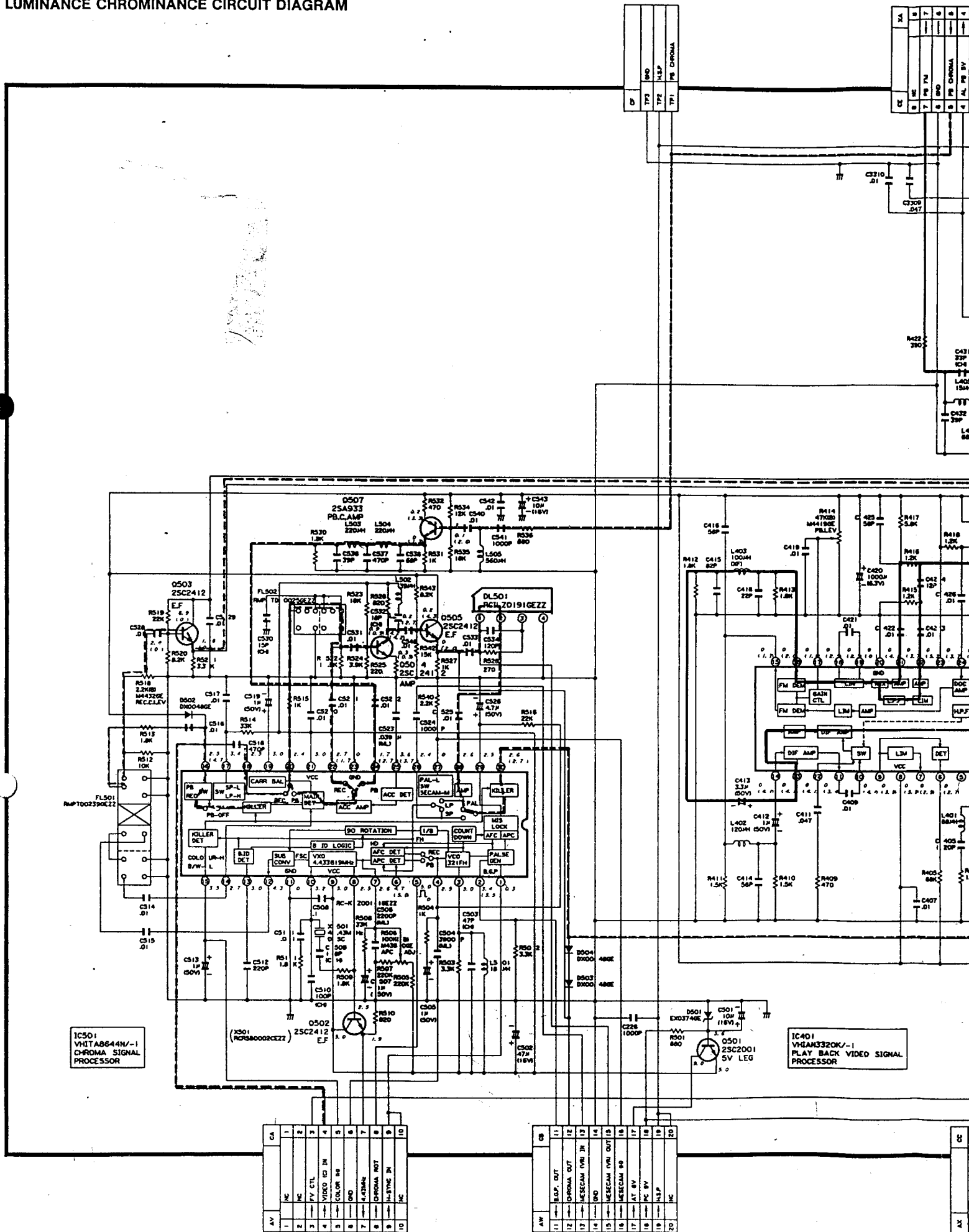

IC501
VHT1A8644N-1
CHROMA SIGNAL
PROCESSOR

IC401
VHTA8320K-1
PLAY BACK VIDEO SIGNAL
PROCESSOR

AV	1	2	3	4	5	6	7	8	9	10	11	12
	NE	NE	NE	VIDEO ID IN	VIDEO ID IN	COLOR IN	VIDEO IN	VIDEO IN	VIDEO IN	VIDEO IN	VIDEO IN	VIDEO IN

AW	11	12	13	14	15	16	17	18	19	20
	B.G.P. OUT	CHROMA OUT	MESECAM VRI IN	MESECAM VRI IN	MESECAM VRI OUT	MESECAM IN	AT 8V	PC 8V	ALP	NE

——— Record Luminance signal
 - - - - Record Chrominance signal
 - - - - Video E-E signal

——— Playback Luminance signal
 - - - - Playback Chrominance signal

* ATTENTION *
 DIODE 9N1-DX0048EZZ
 or 9N1-DX00538EZZ
 (ALTERNATE PART)

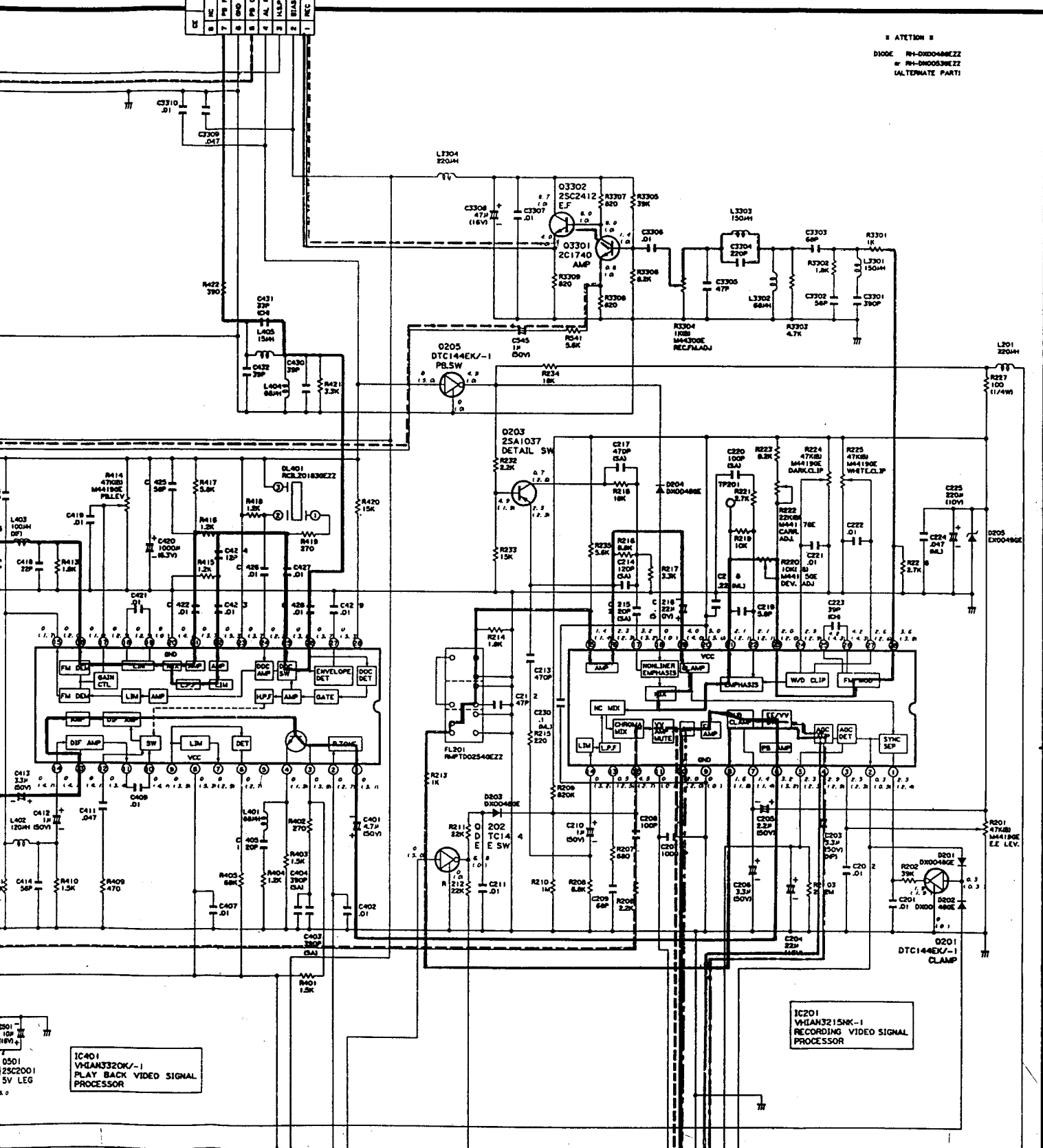

IC401
 VHIAN320K/-1
 PLAY BACK VIDEO SIGNAL
 PROCESSOR

IC201
 VHIAN3215K/-1
 RECORDING VIDEO SIGNAL
 PROCESSOR

21	AL	PM	BV
22	BIAS	CTL	
23	NC		
24	NC		
25	P-TONE		
26	E-E	CL	

27	TV		
28	VIDEO	OUT	
29	VIDEO	IN	
30	VIDEO	TT	IN
31	ACC	DET	
32	H-SYNC	OUT	

0501
 25C2001
 5V LEG

AUDIO CIRCUIT DIAGRAM

- Audio Record signal
- - - Audio Playback signal
- · · Audio E-E signal

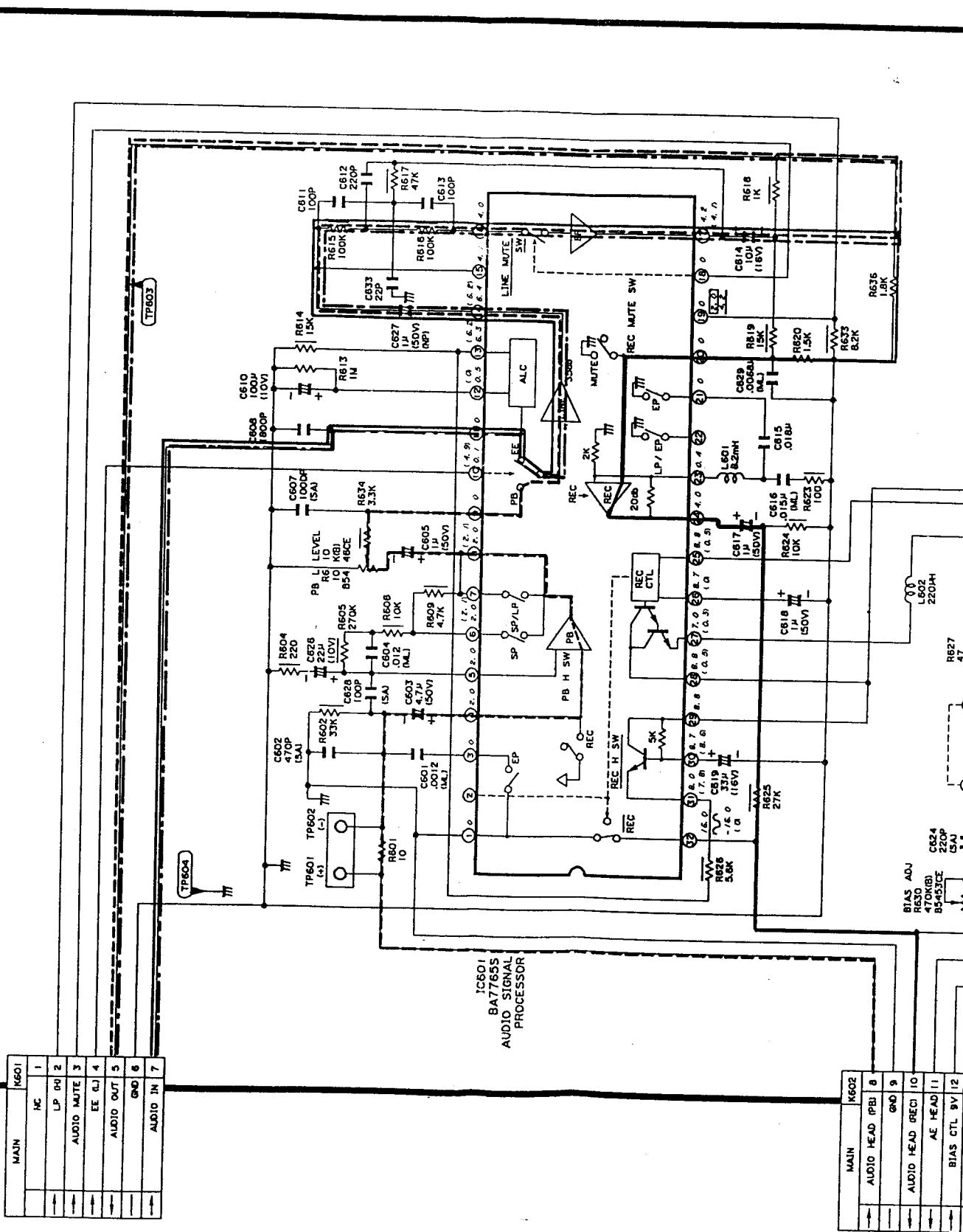

MAIN	IC601
	1 IC
	2 LP DR
	3 AUDIO MUTE
	4 EE RL
	5 AUDIO OUT
	6 GND
	7 AUDIO IN

MAIN	IC602
	8 AUDIO HEAD (PB)
	9 GND
	10 AUDIO HEAD (REC)
	11 AE HEAD
	12 BIAS CTL

- Audio Record signal
- - - Audio Playback signal
- · · Audio E-E signal

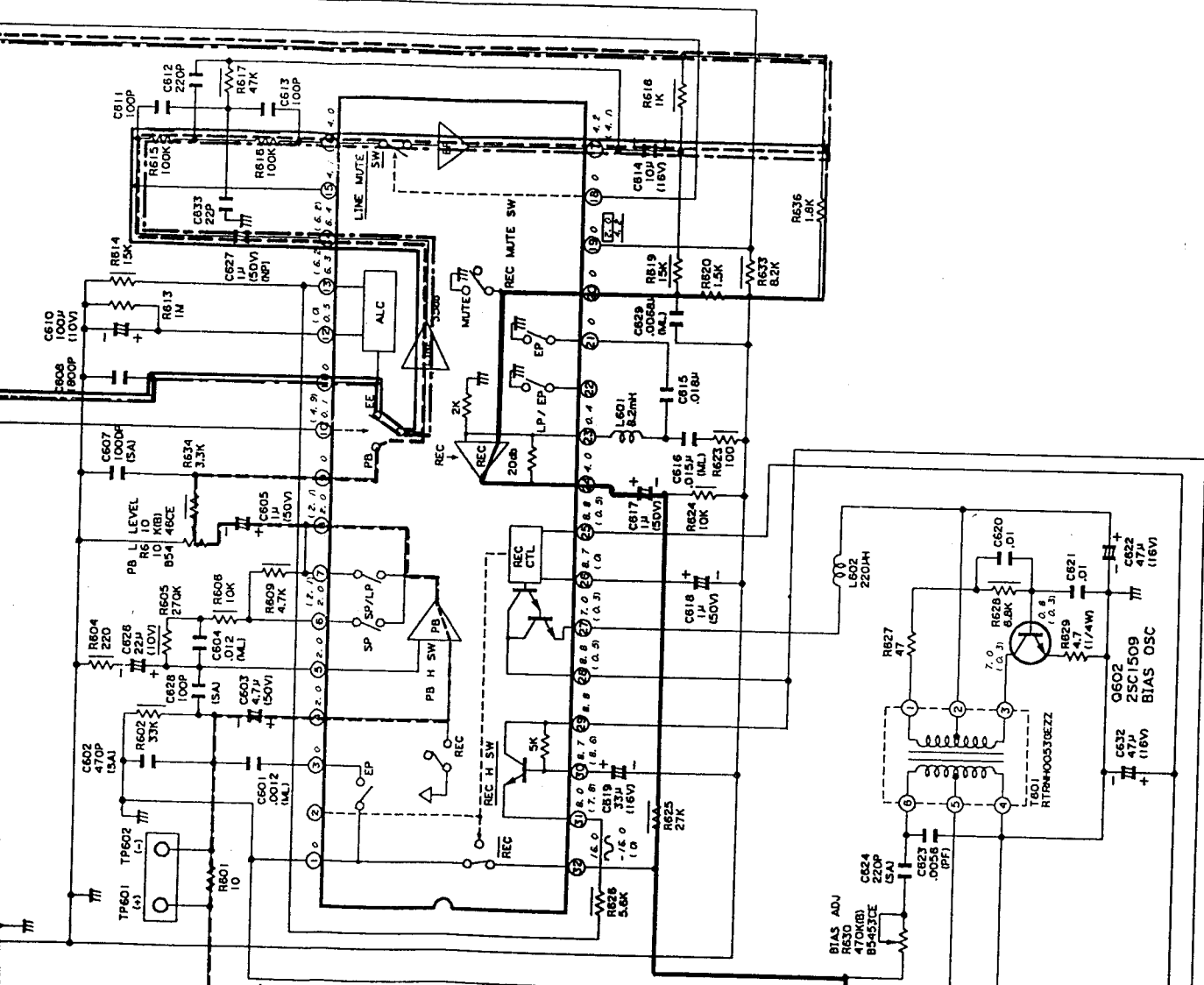

IC601
BA77655
AUDIO SIGNAL
PROCESSOR

MAIN	KG02
AUDIO HEAD (PB)	8
GROUND	9
AUDIO HEAD (REC)	10
AE HEAD	11
BIAS CTL 9V	12
PC 9V	13
GROUND	14

IF PACK CIRCUIT DIAGRAM

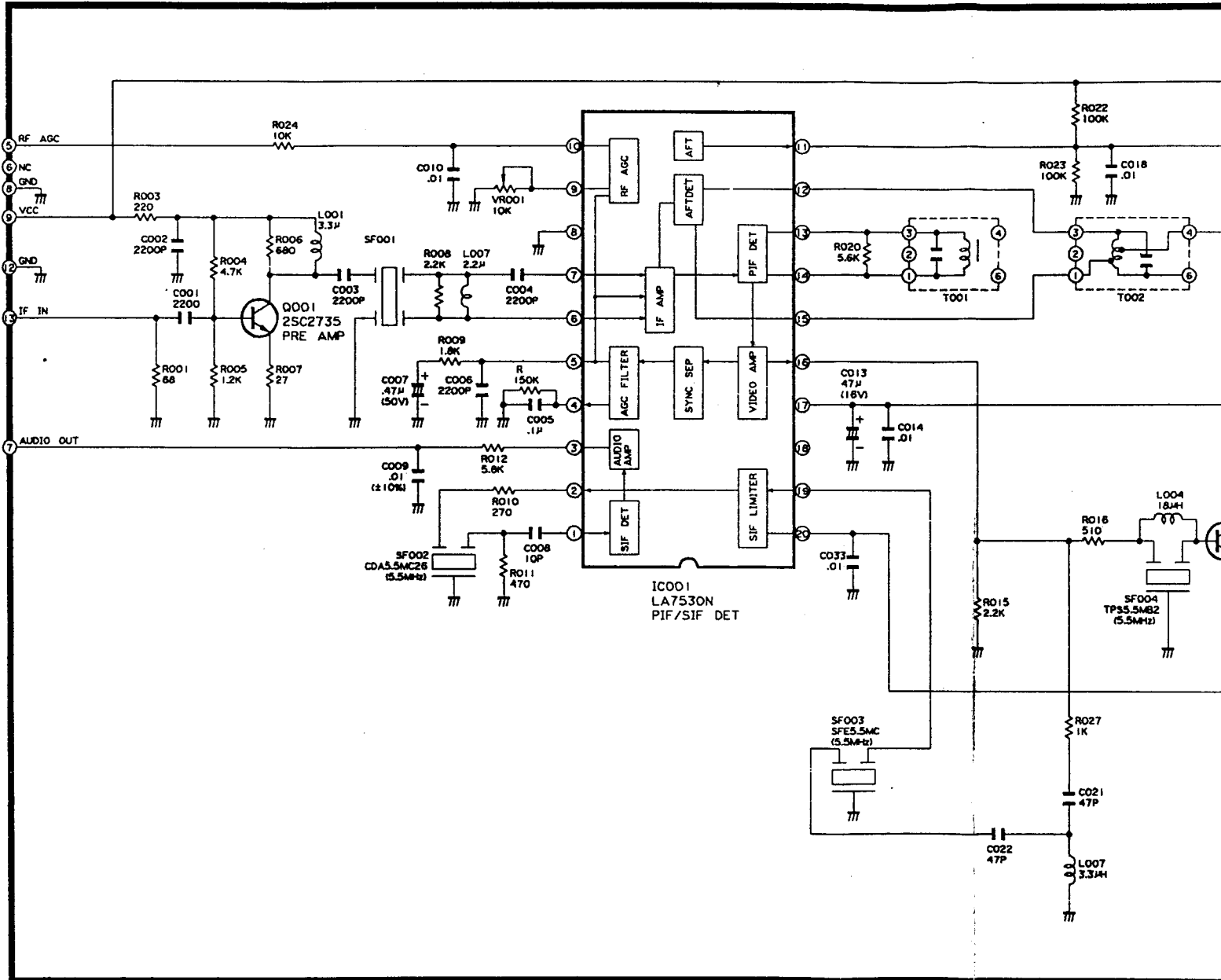

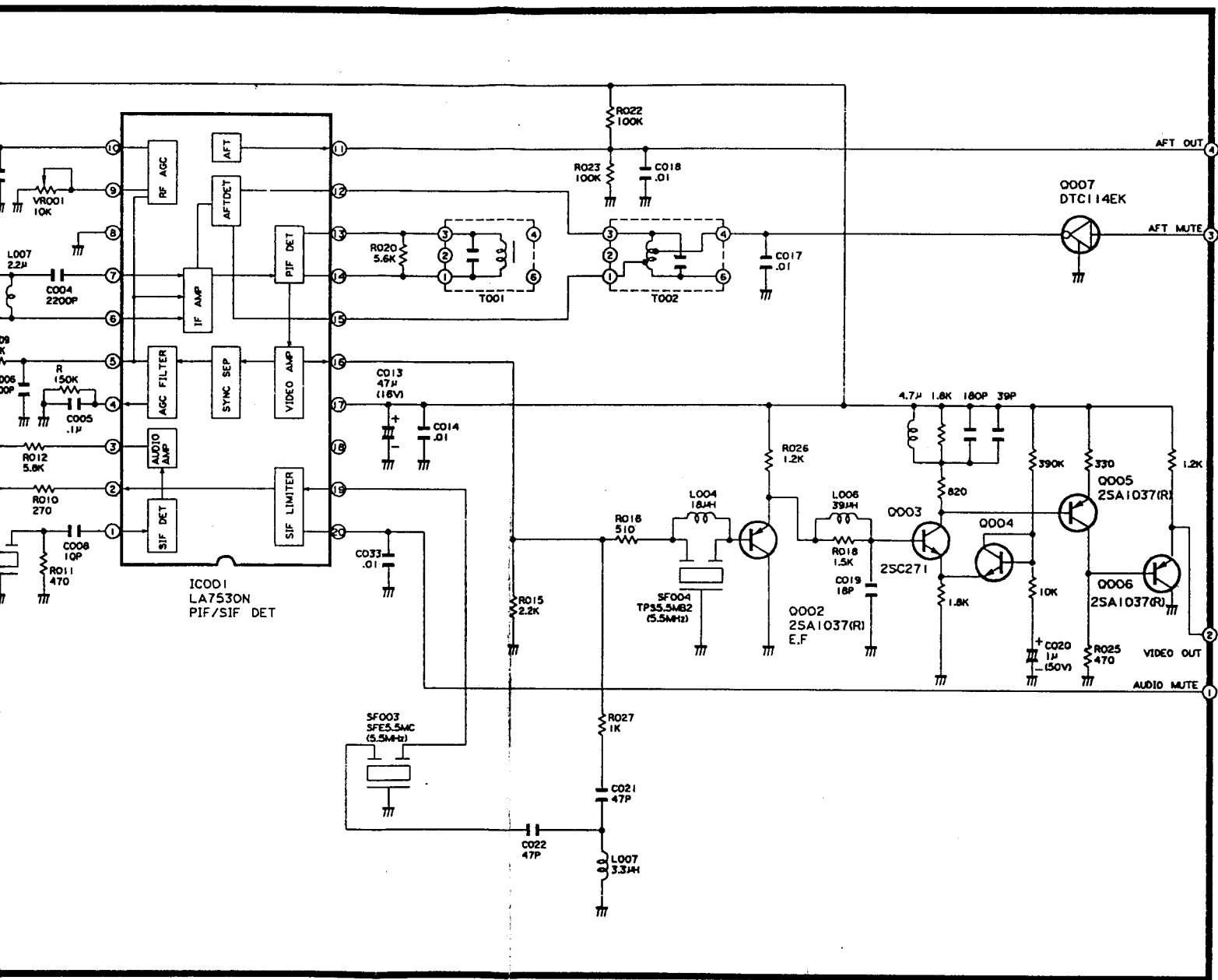

TIMER CIRCUIT DIAGRAM OPERATION CIRCUIT DIAGRAM

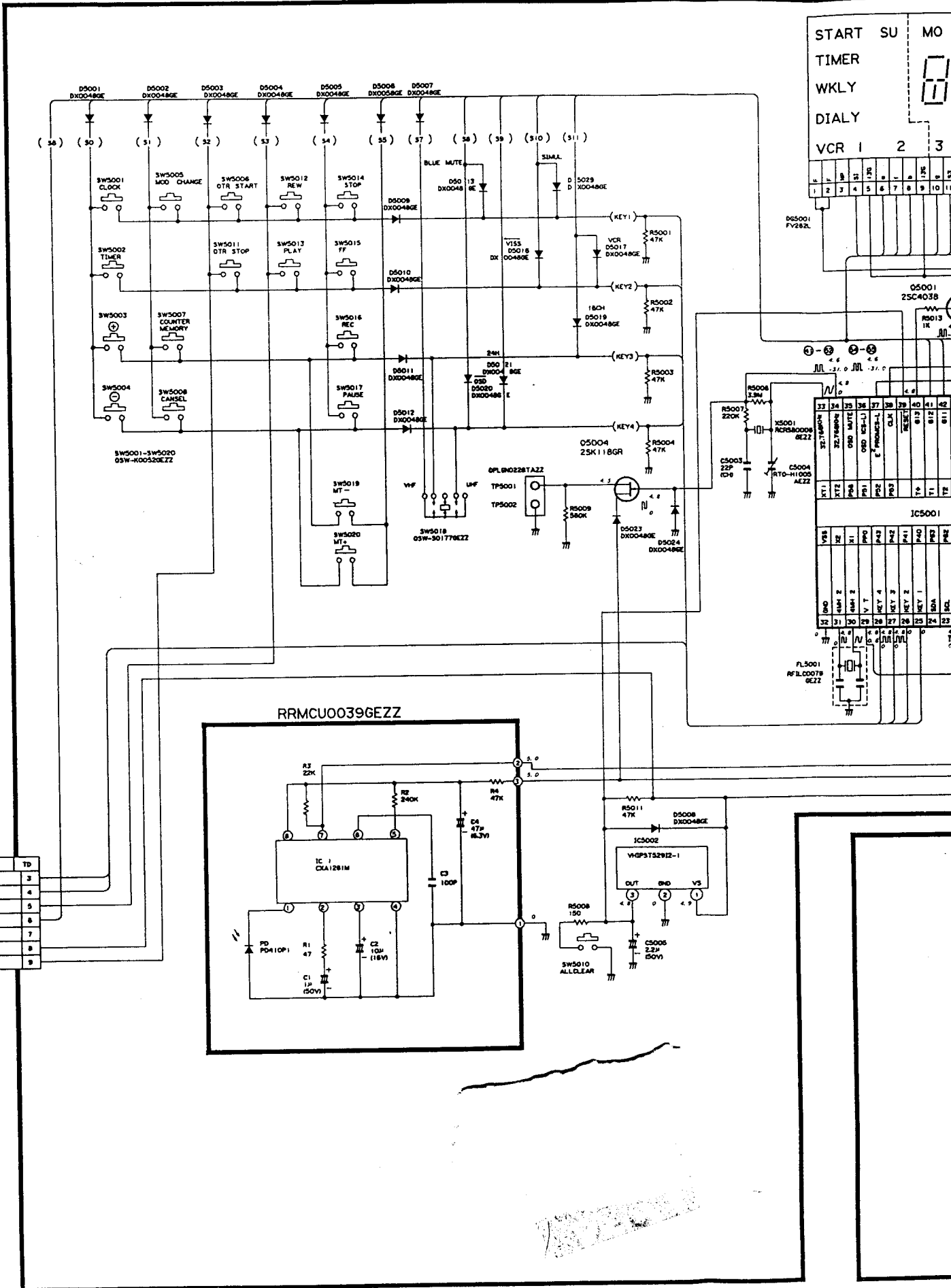

NA	030C2718GEZZ	TD
3	KEY 3	3
4	KEY 4	4
5	33	5
6	34	6
7	MC	7
8	BACK UP	8
9	32	9

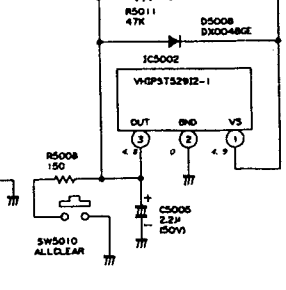
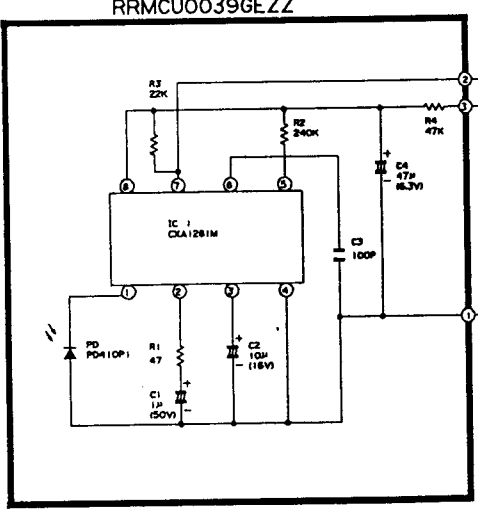
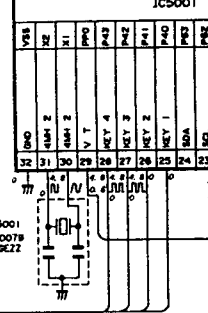
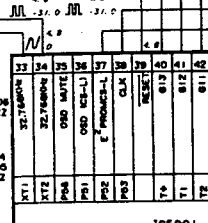
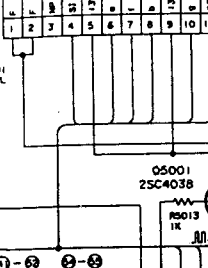
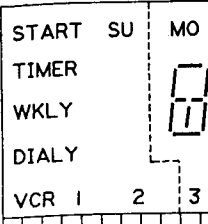

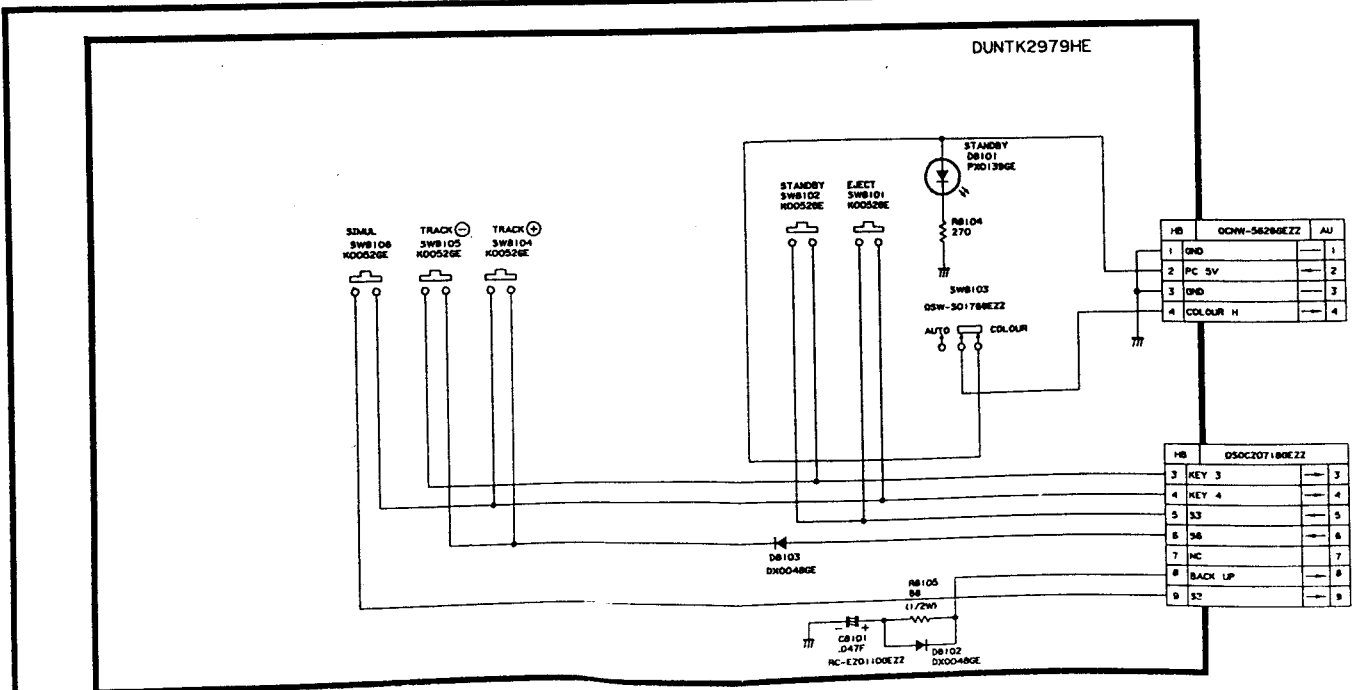
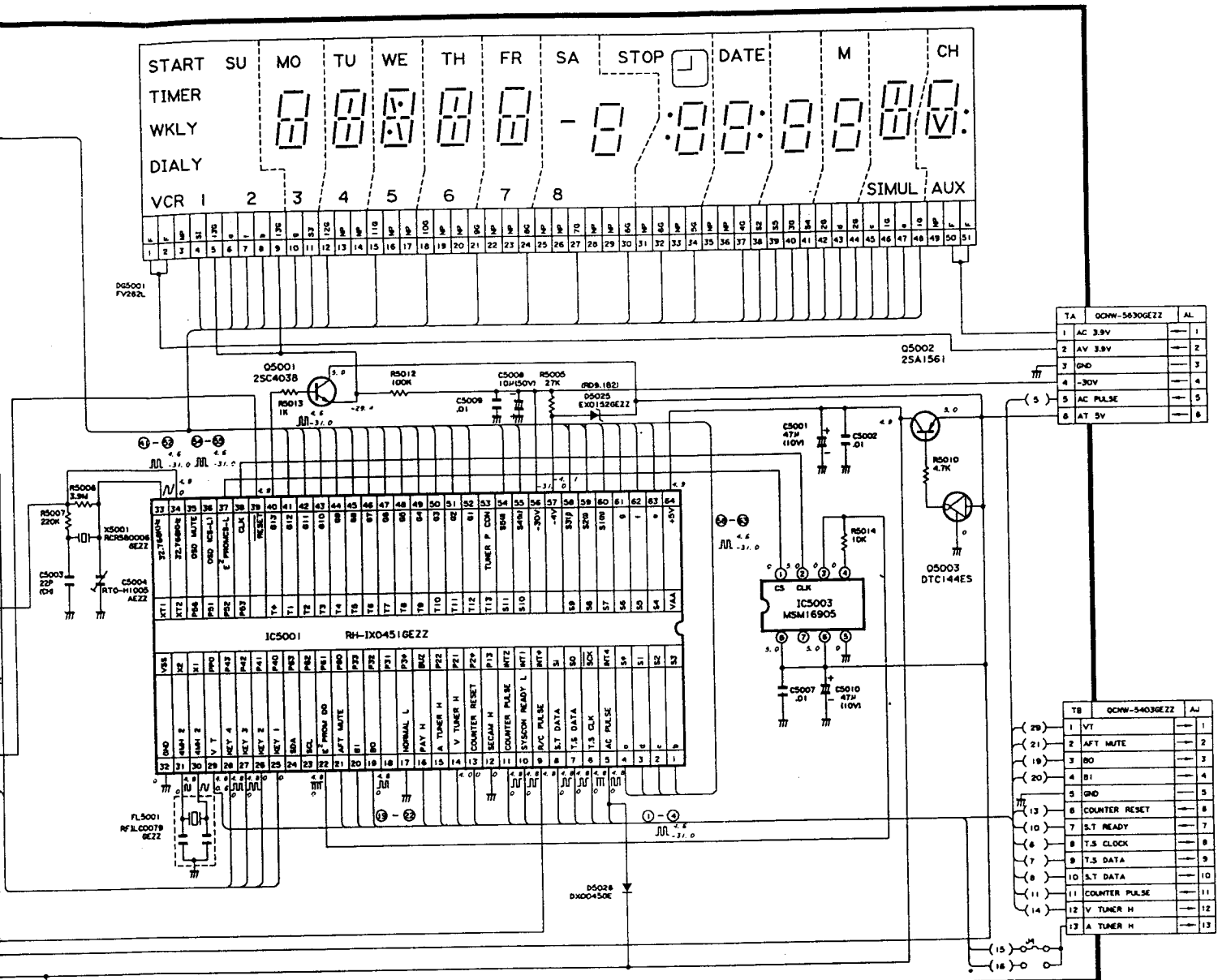

HEAD AMPLIFIER CIRCUIT DIAGRAM

_____ Playback Luminance signal
 - - - - - Playback Chrominance signal

VIDEO HEAD		ZA
ZA1	→ GND	1
ZA2	→ V-HEAD PB (2-A)	2
ZA3	→ V-HEAD REC (2-B)	3
ZA4	→ V-HEAD PB (1-A)	4
ZA5	→ GND	5

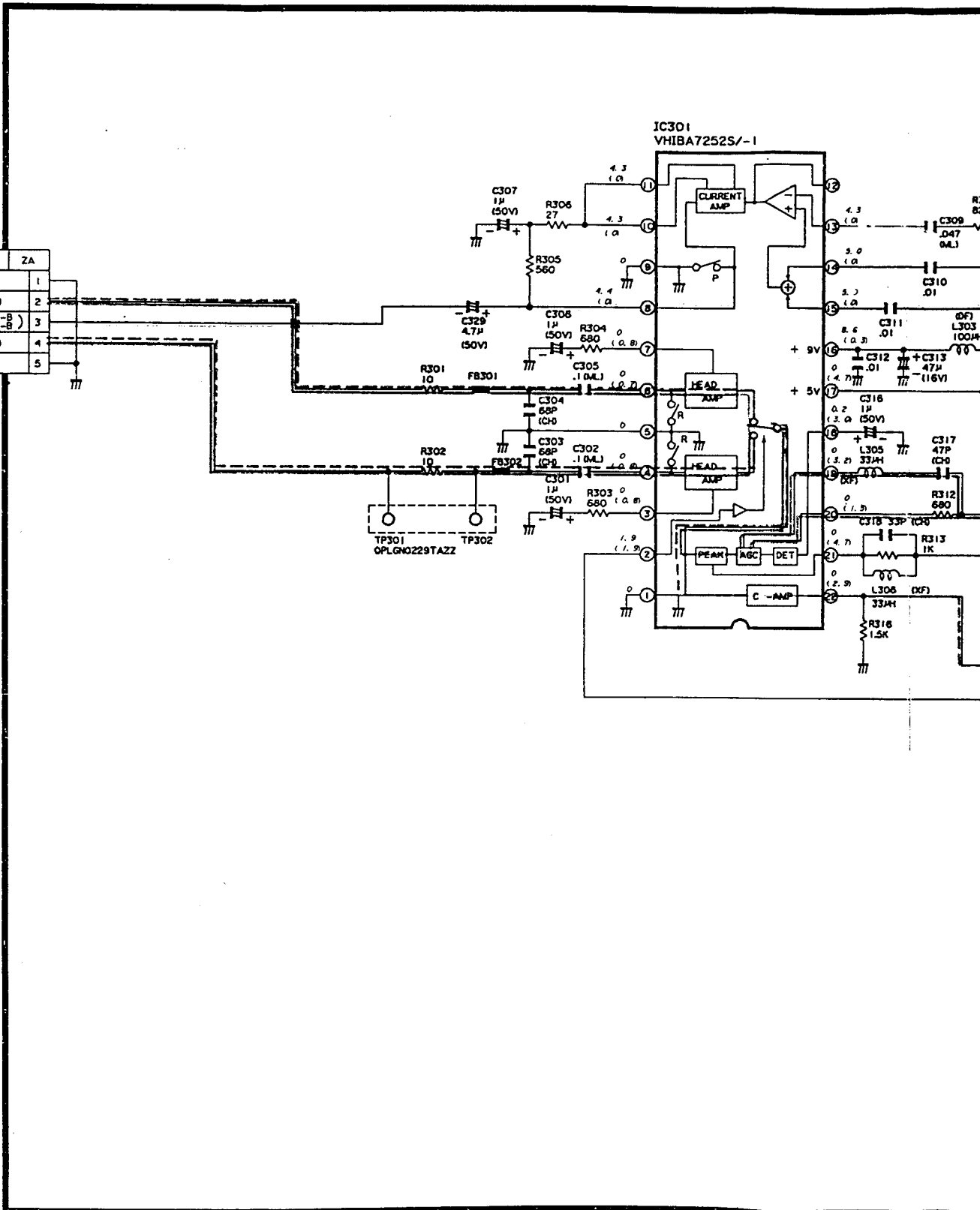

_____ Playback Luminance signal
 _____ Playback Chrominance signal

_____ Record Luminance signal
 _____ Record Chrominance signal

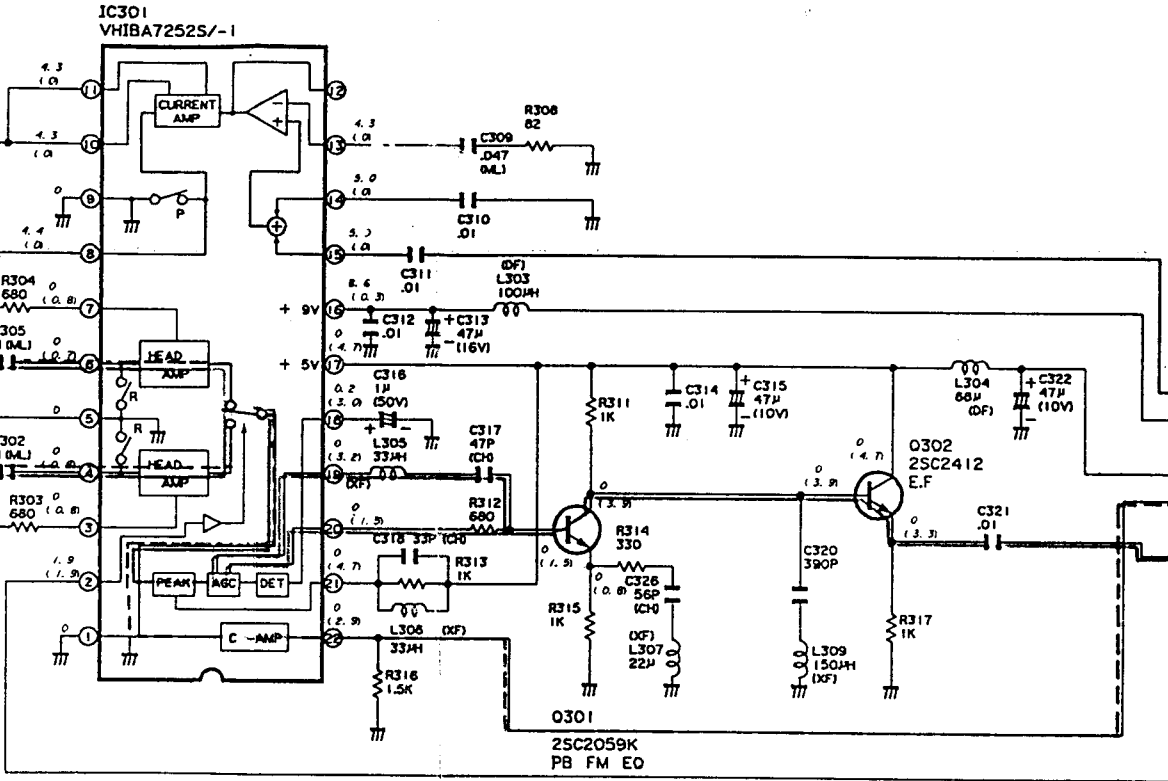

XA	Y/AUDIO	CE
1	REC FM	1
2	BIAS CTL 9V	2
3	H.S.P	3
4	AL PB 5V	4
5	PB CHROMA	5
6	GND	6
7	PB FM	7
8	NC	8

POWER CIRCUIT DIAGRAM

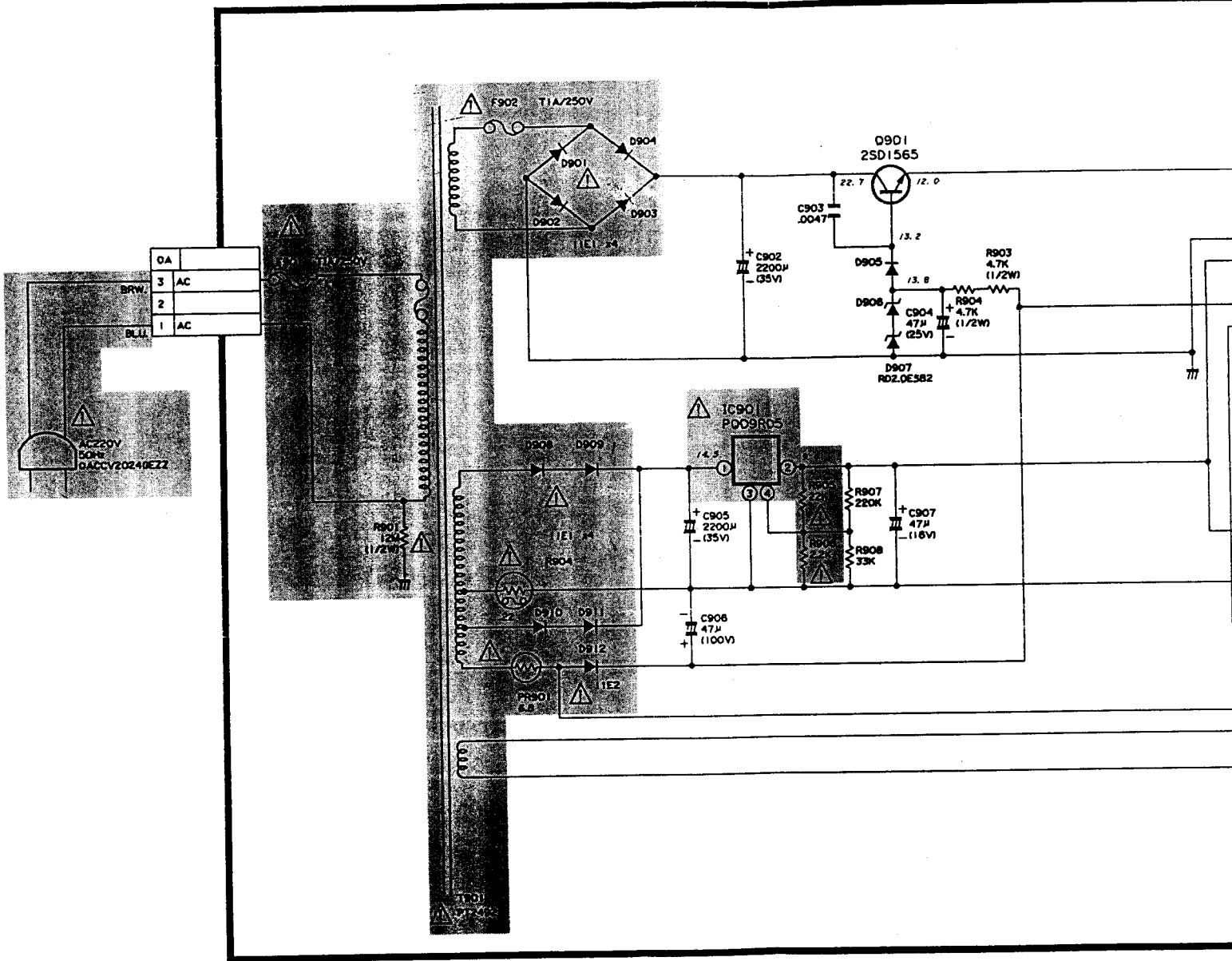

CIRCUIT DIAGRAM

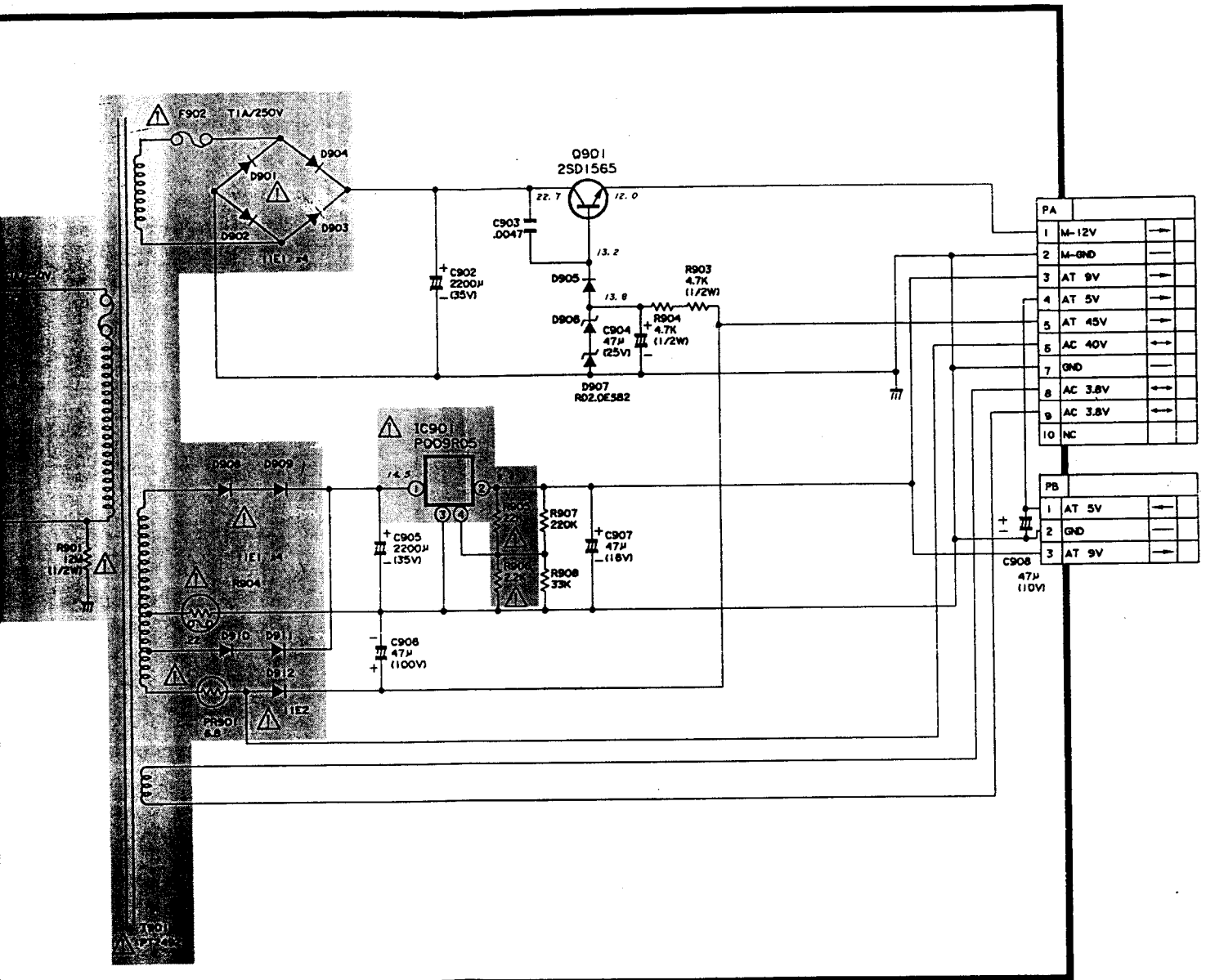

SERVO, SYSTEM CONTROL, IF TUNER CIRCUIT

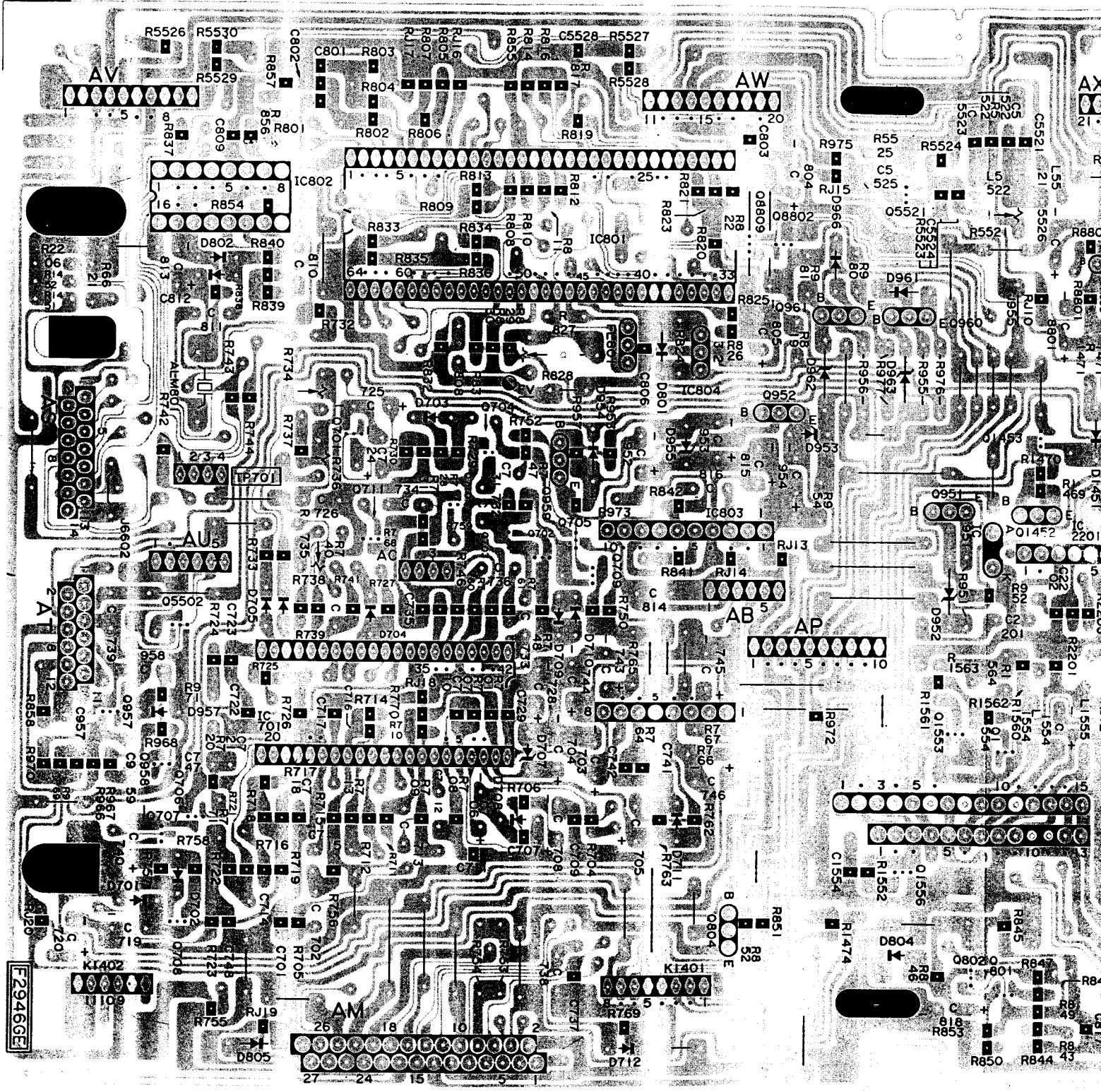

SERVO, SYSTEM CONTROL, IF TUNER CIRCUIT

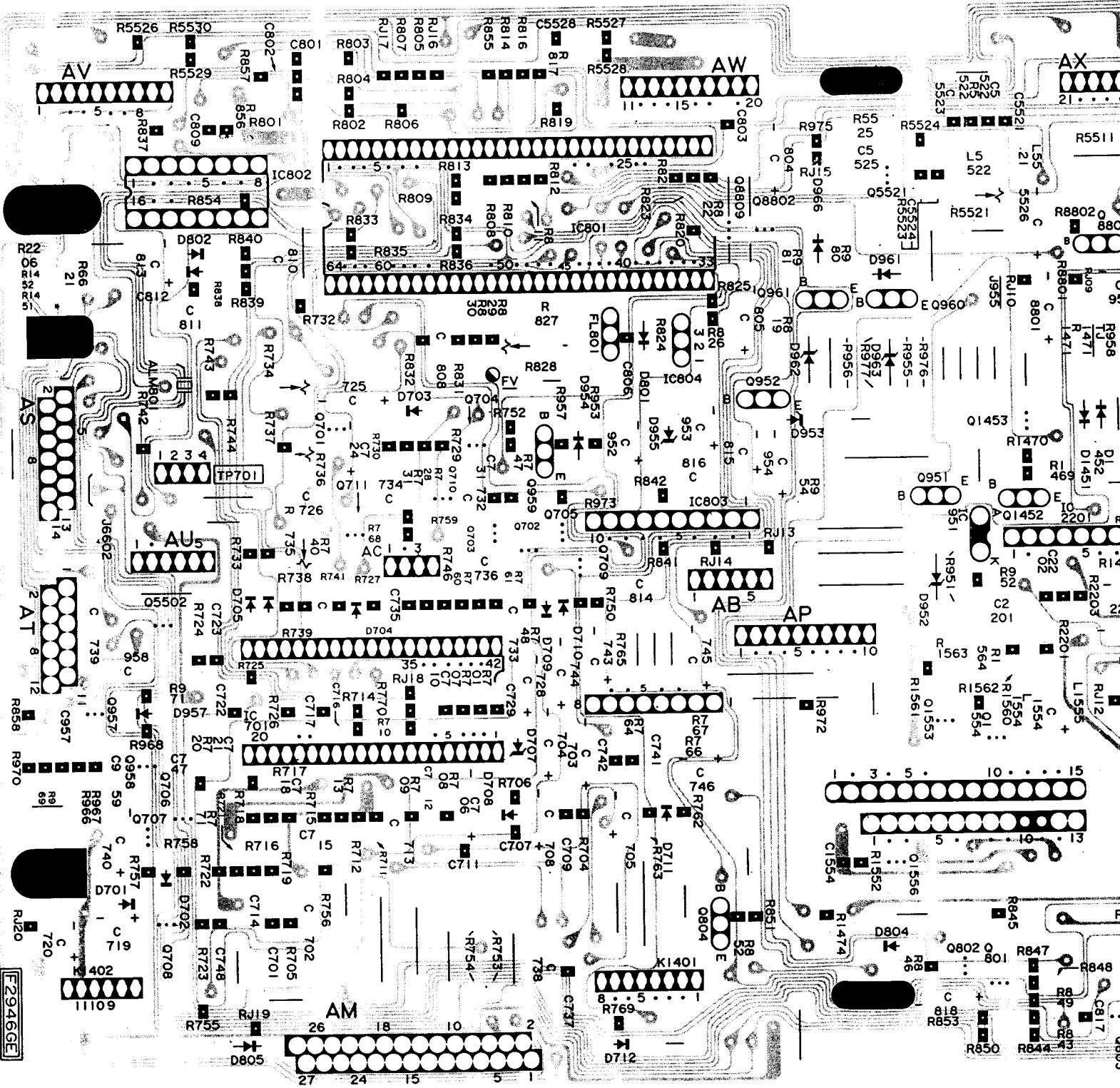

2946GE

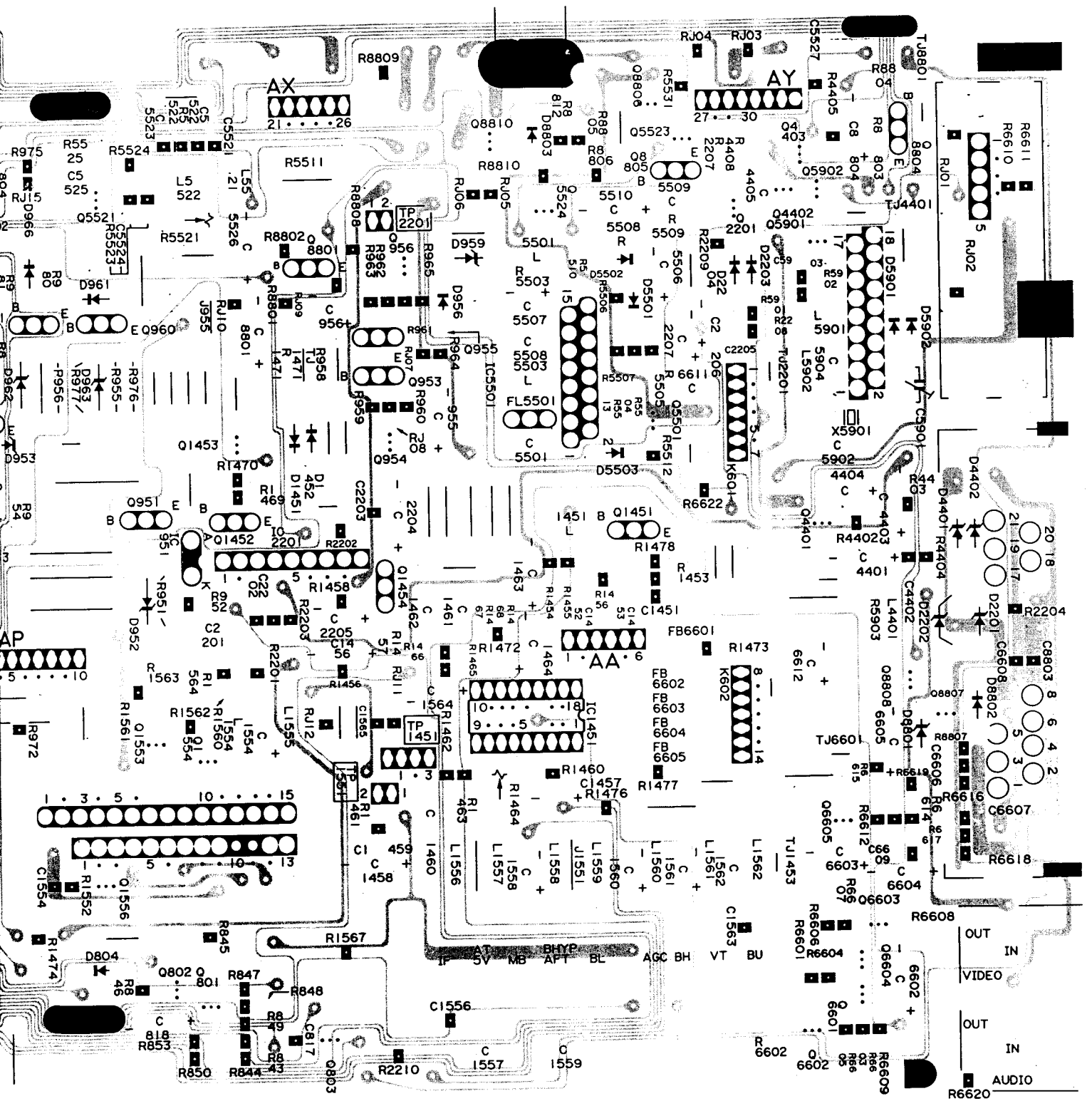

LUMINANCE-CHROMINANCE CIRCUIT

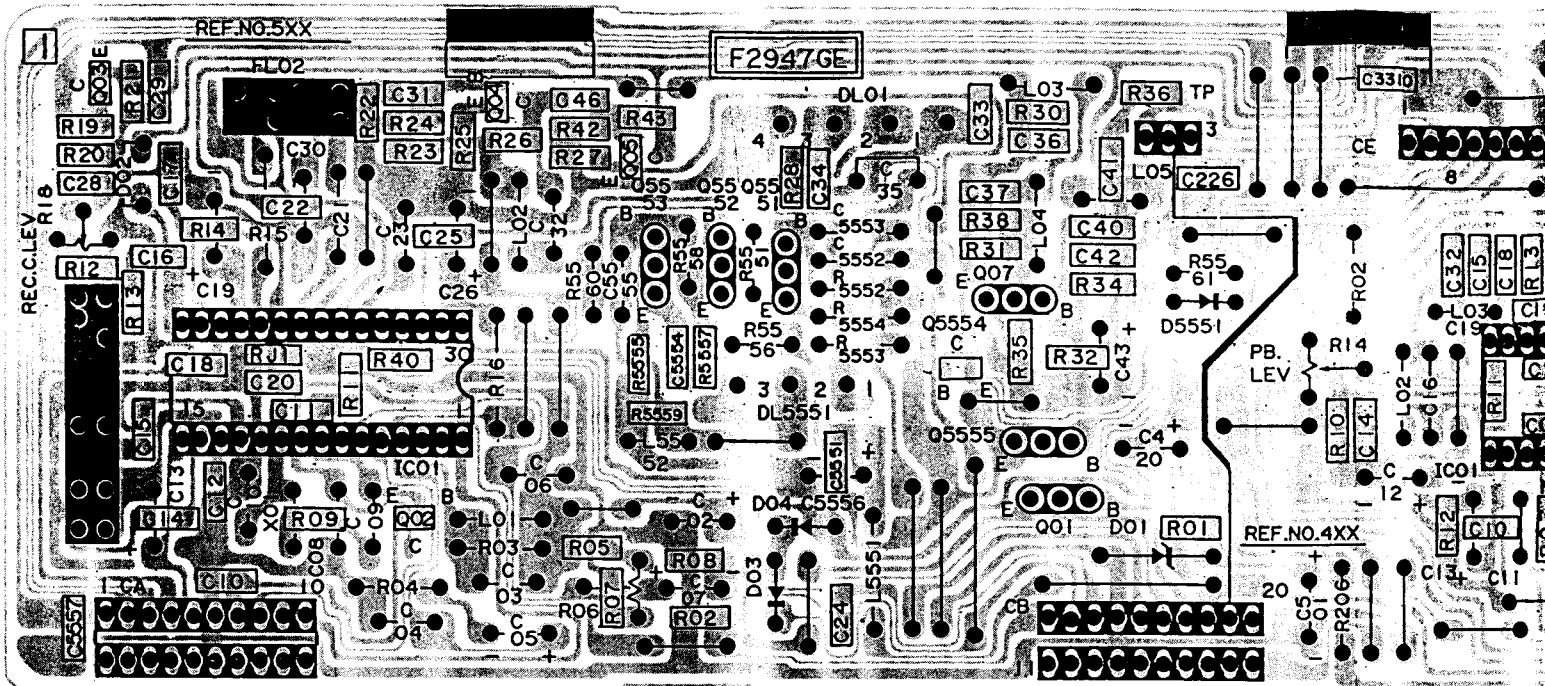

HEAD AMPLIFIER CIRCUIT

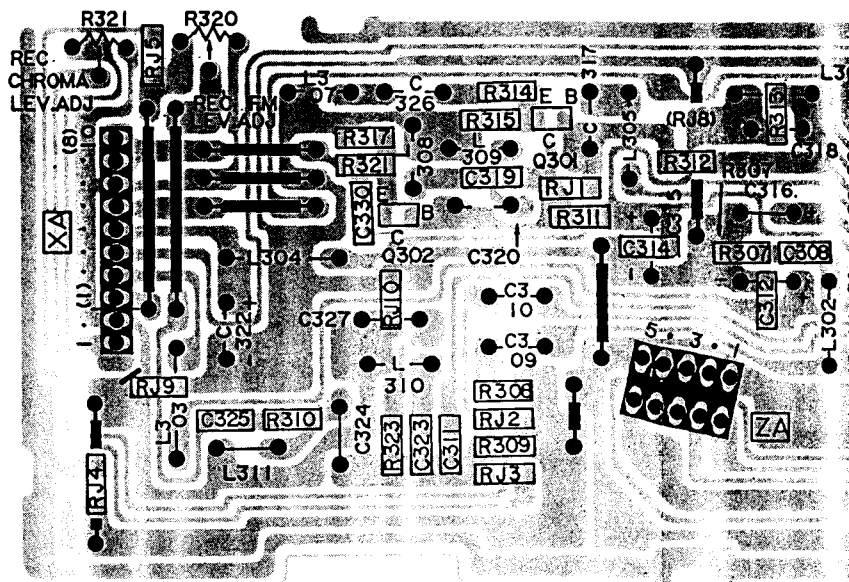

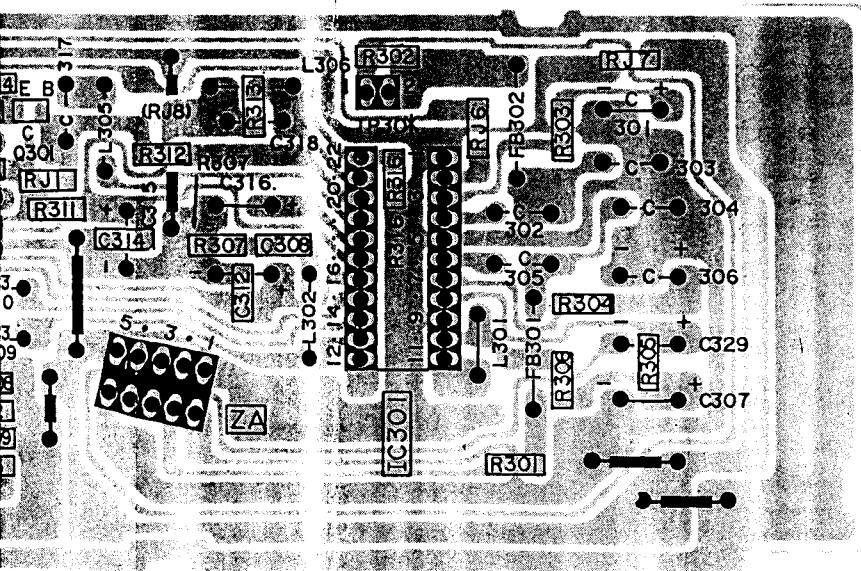
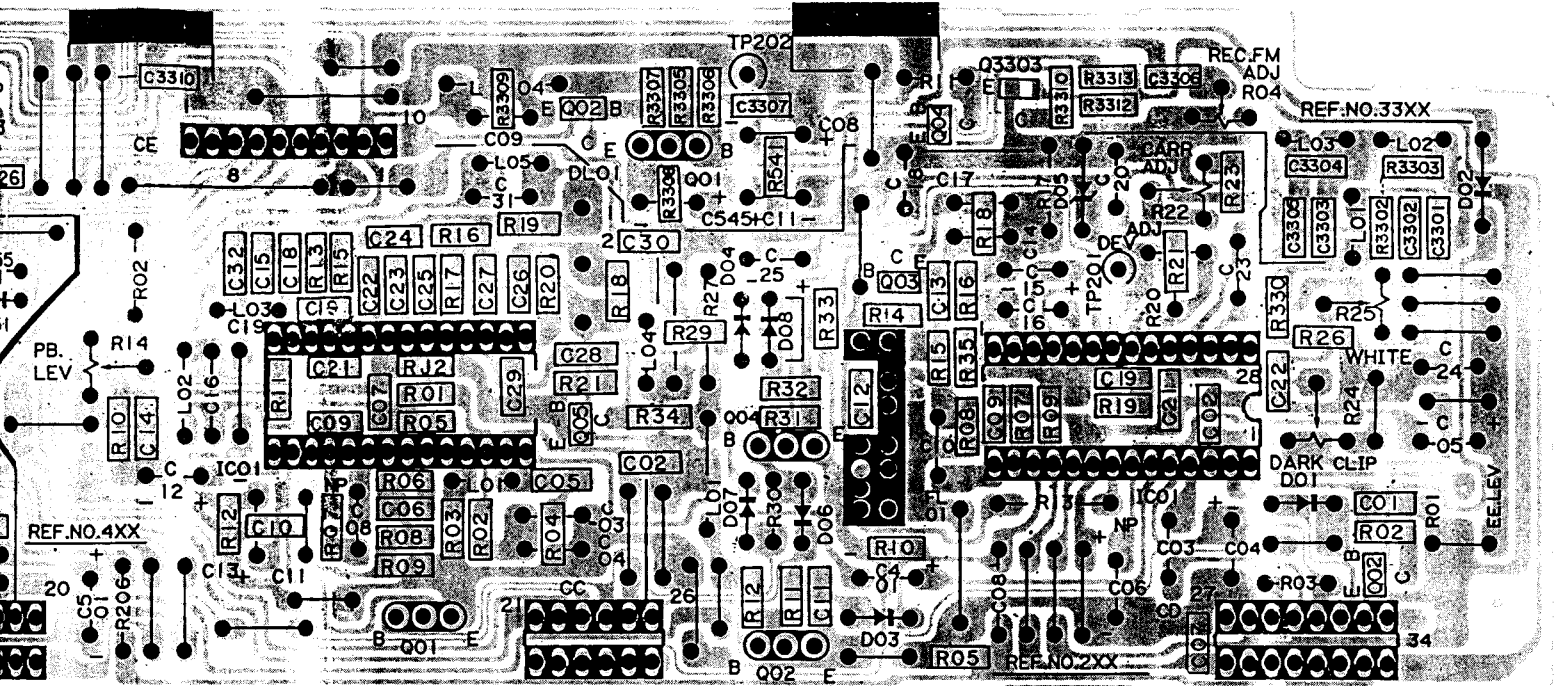

OPERATION CIRCUIT

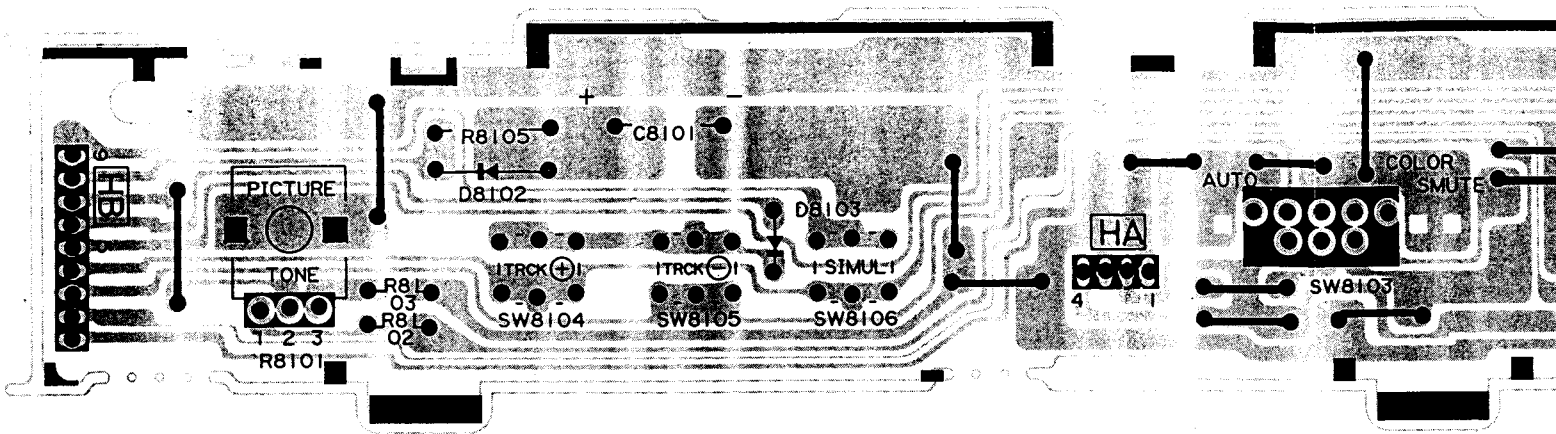

TIMER CIRCUIT

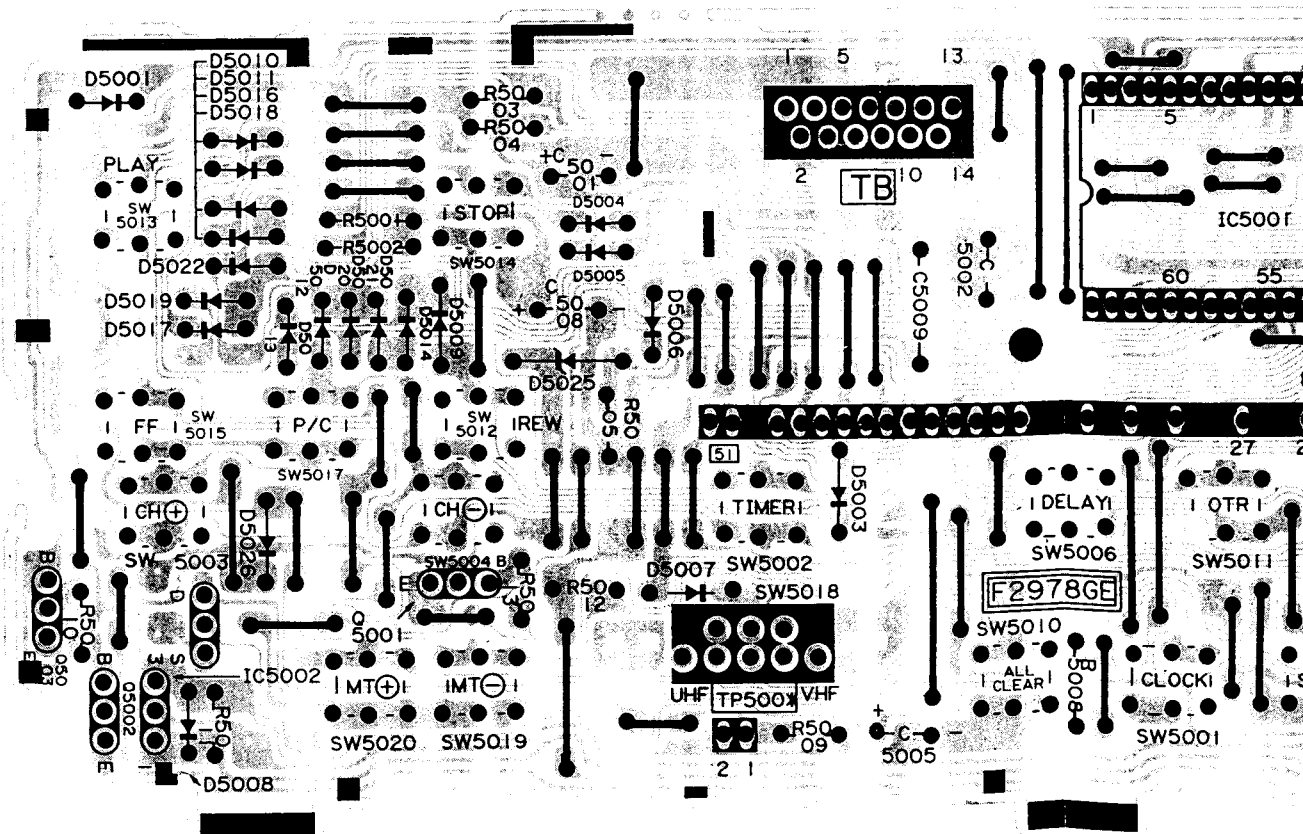

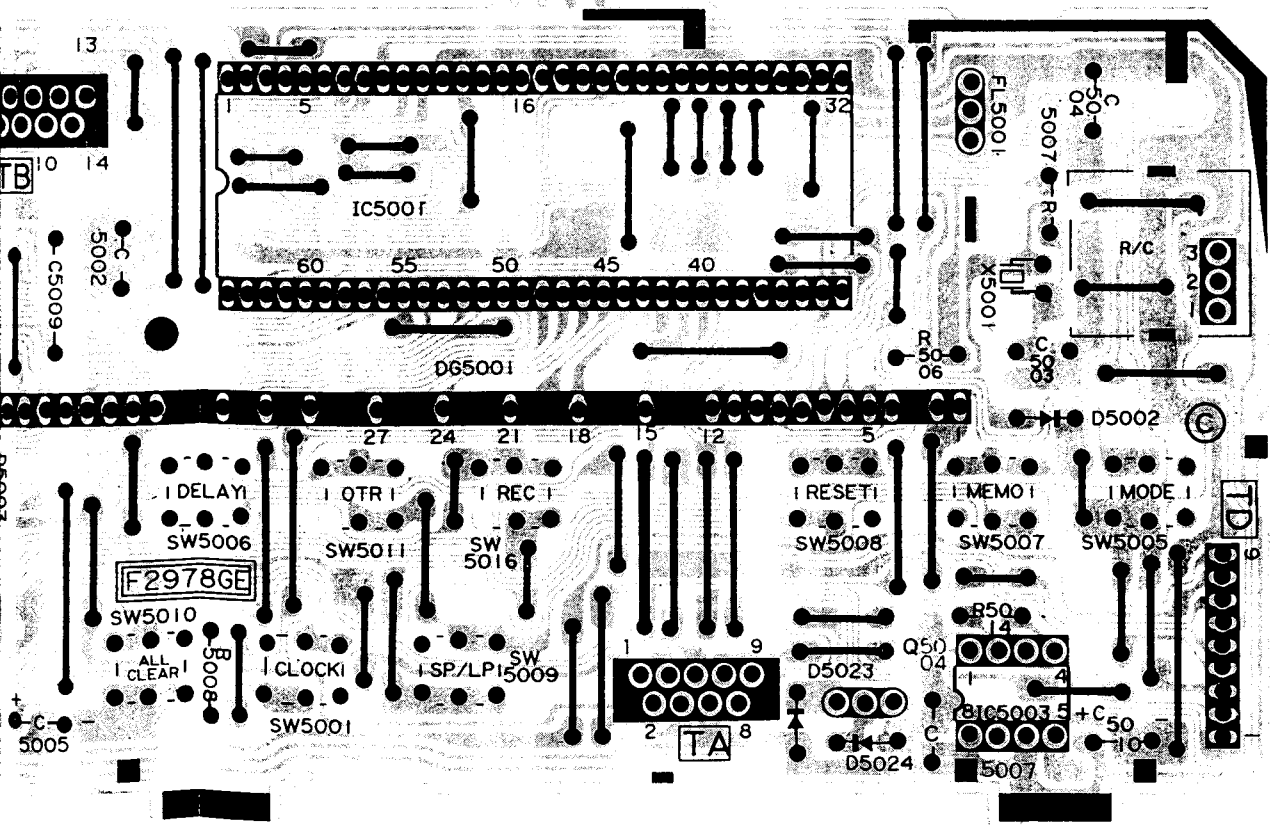
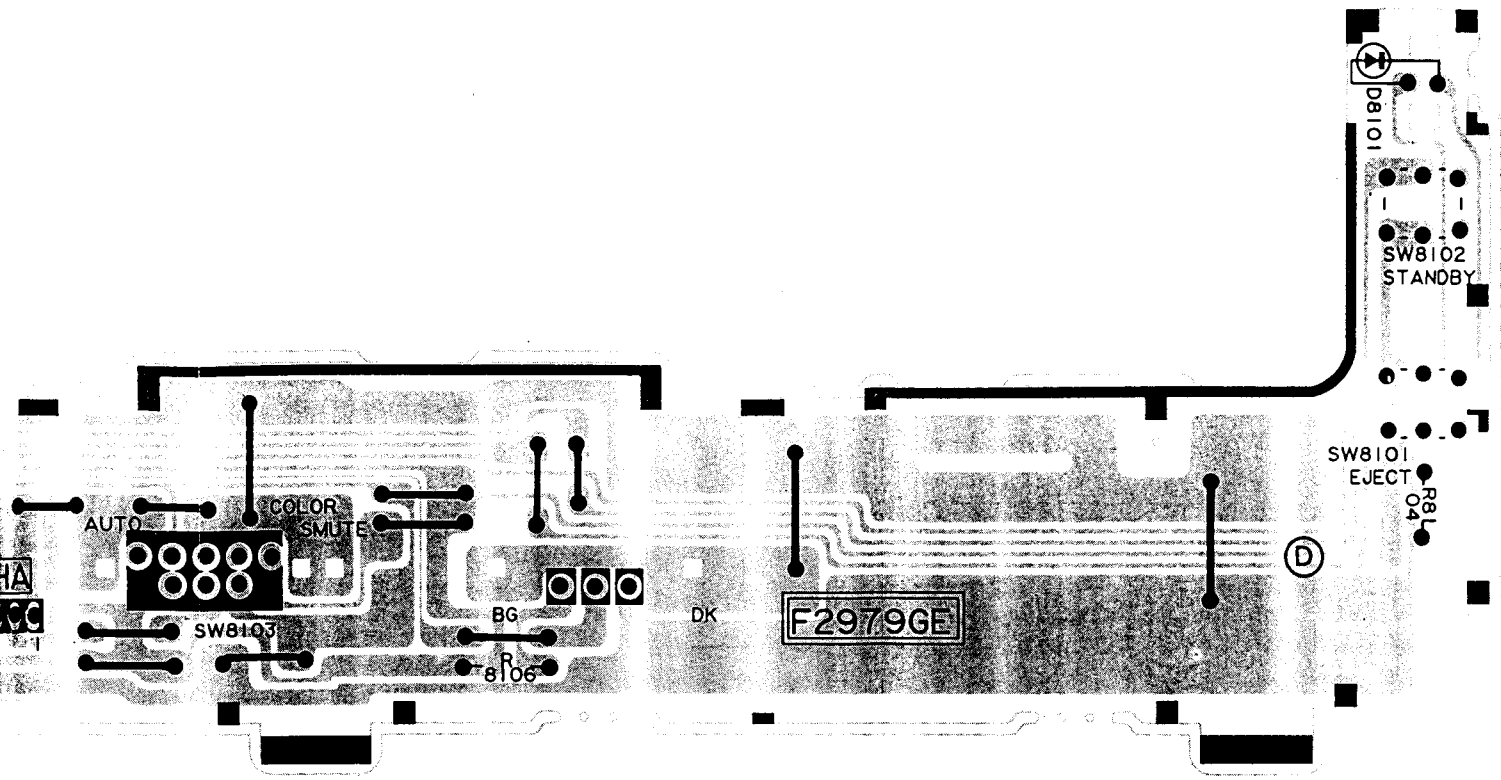

POWER CIRCUIT

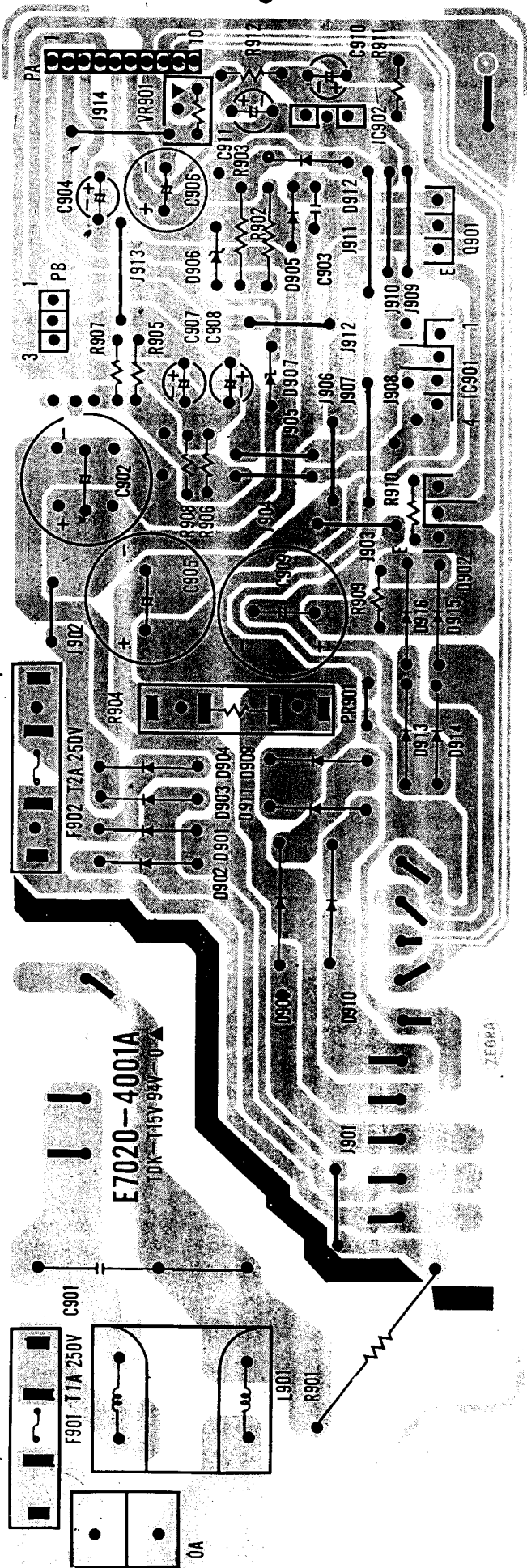

AUDIO CIRCUIT

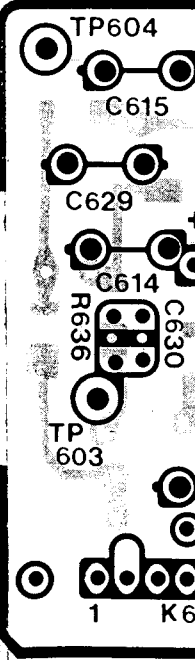
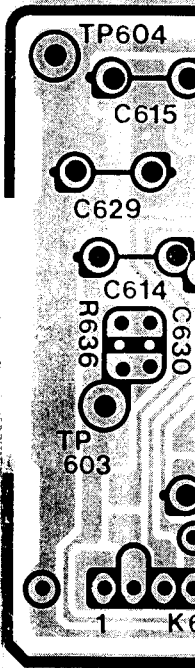

AUDIO CIRCUIT

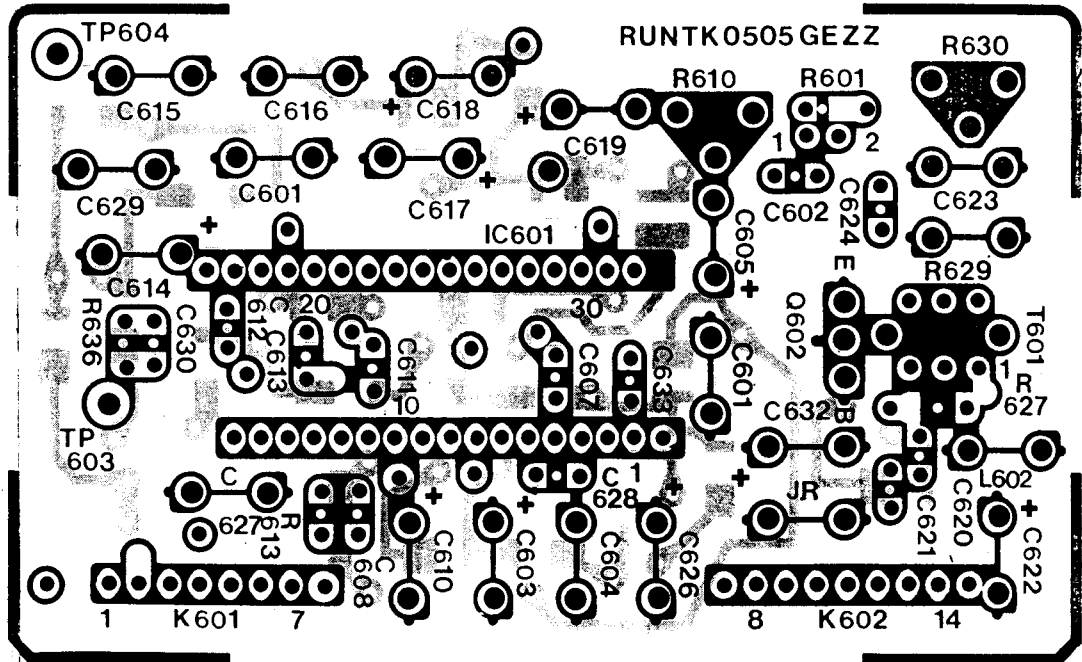
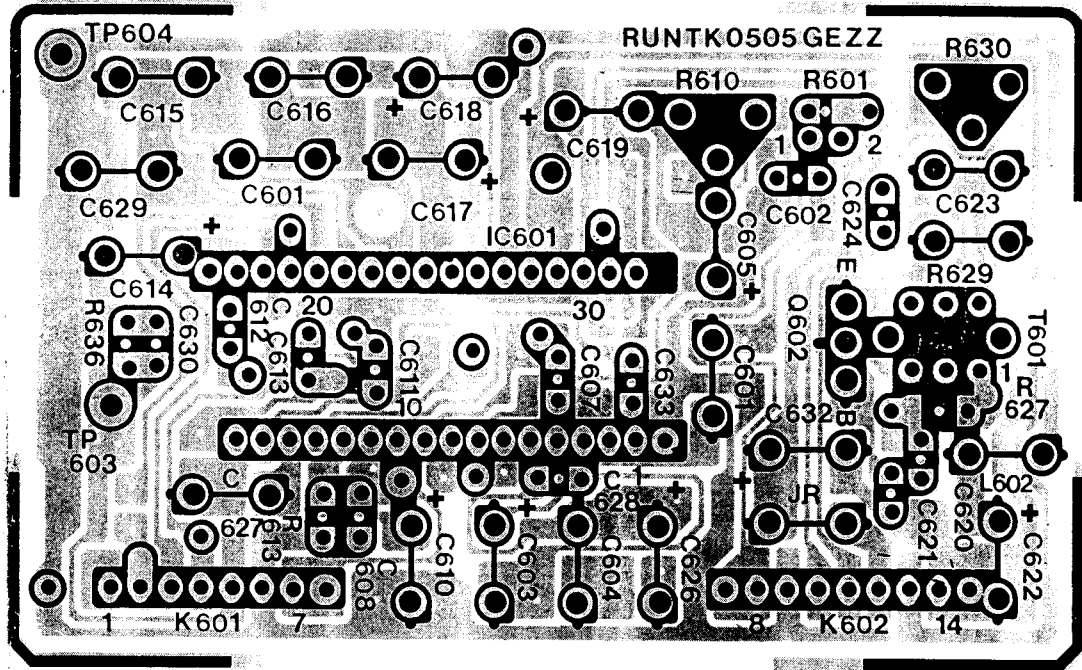

MECHANICAL PARTS

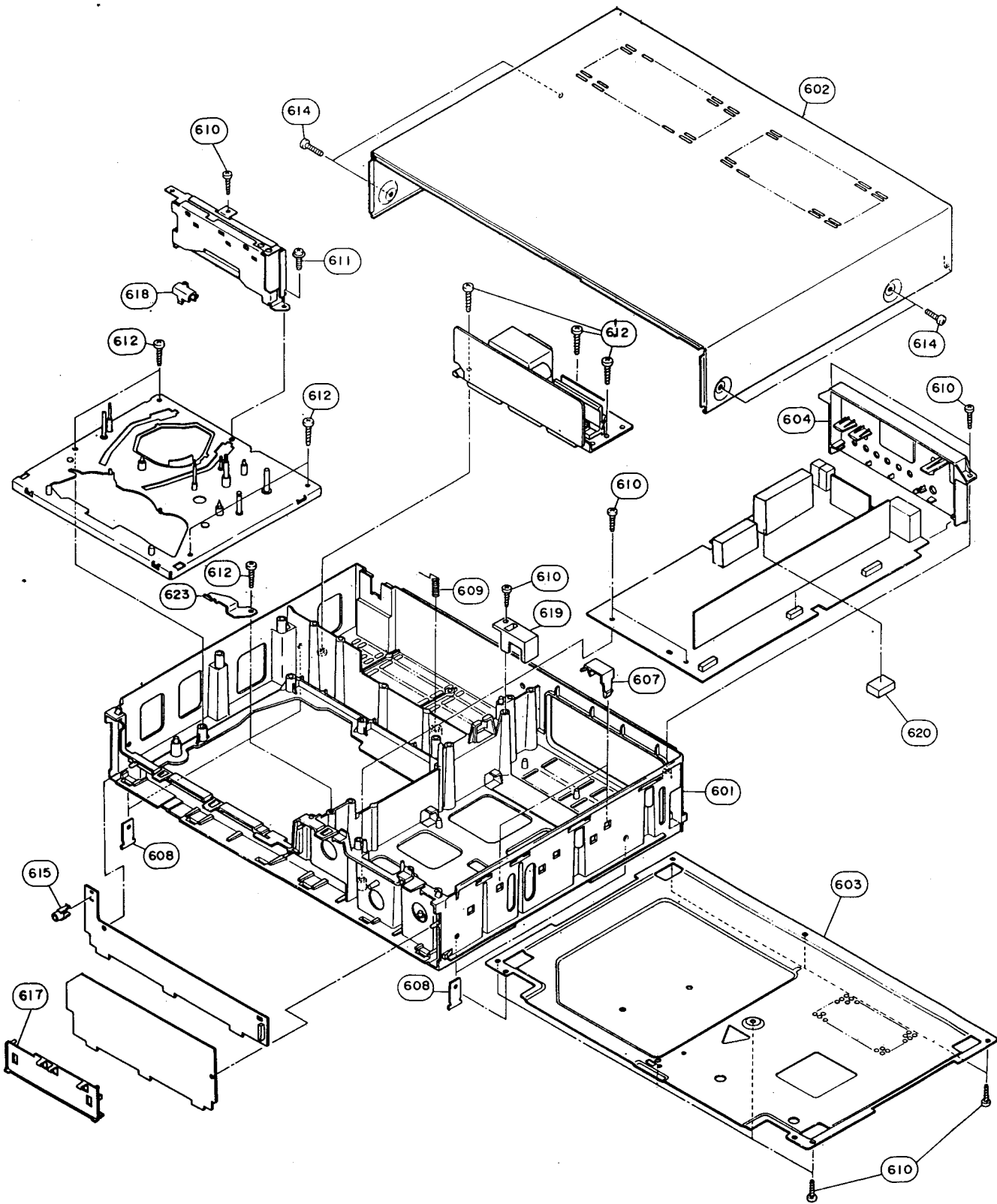

FRONT PARTS

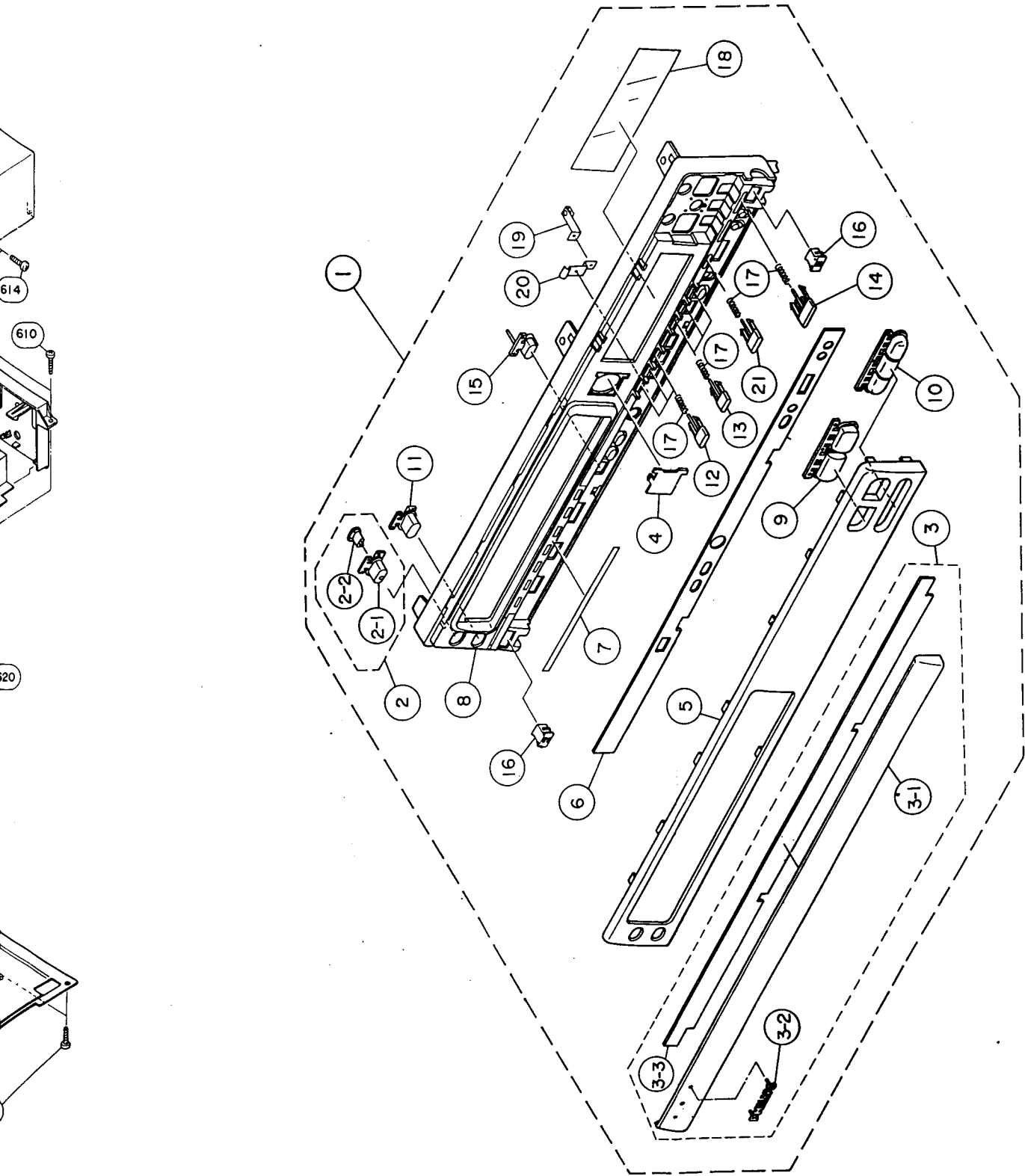

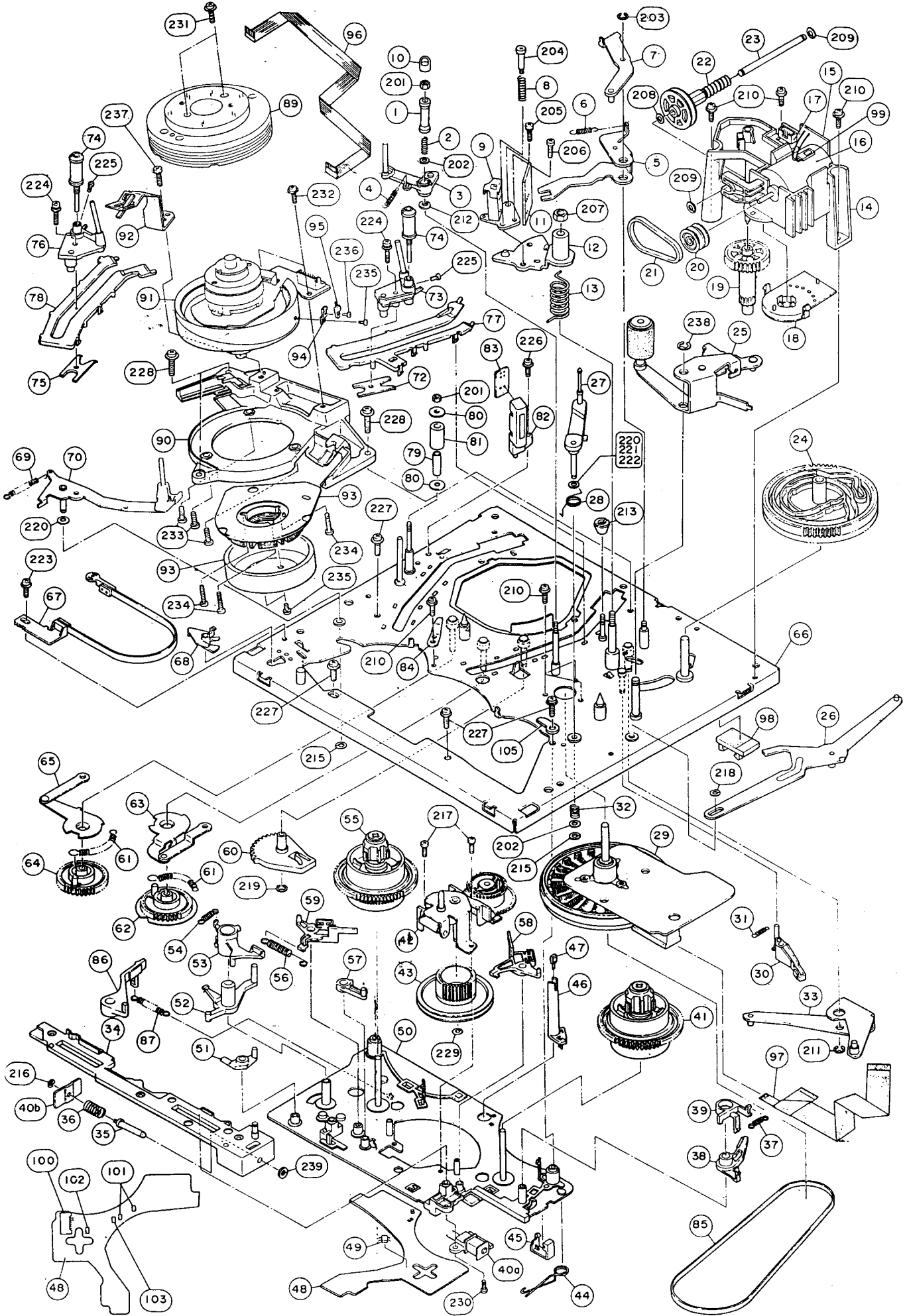

CASSETTE HOUSING CONTROL PARTS

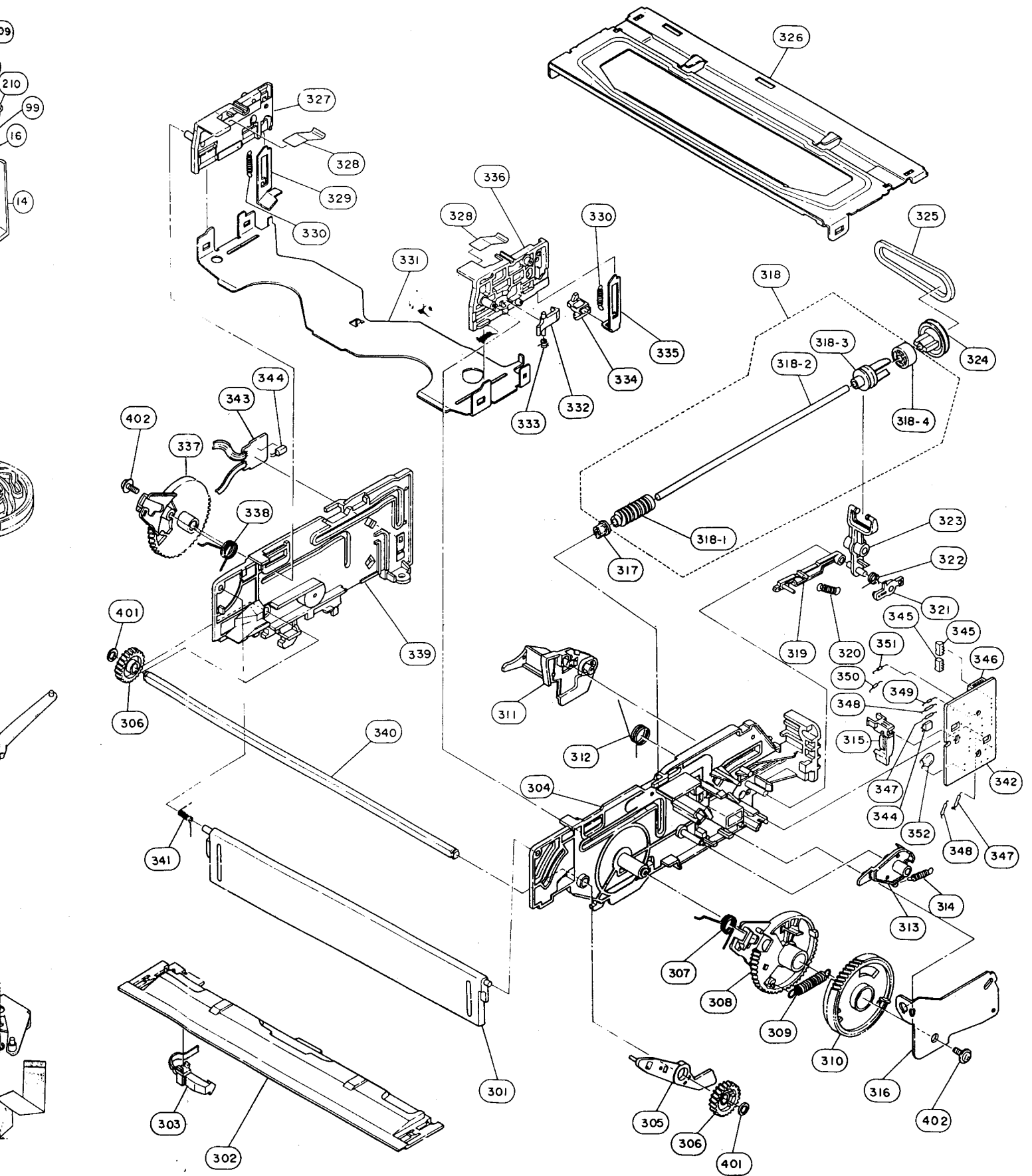

INFRARED REMOTE CONTROL

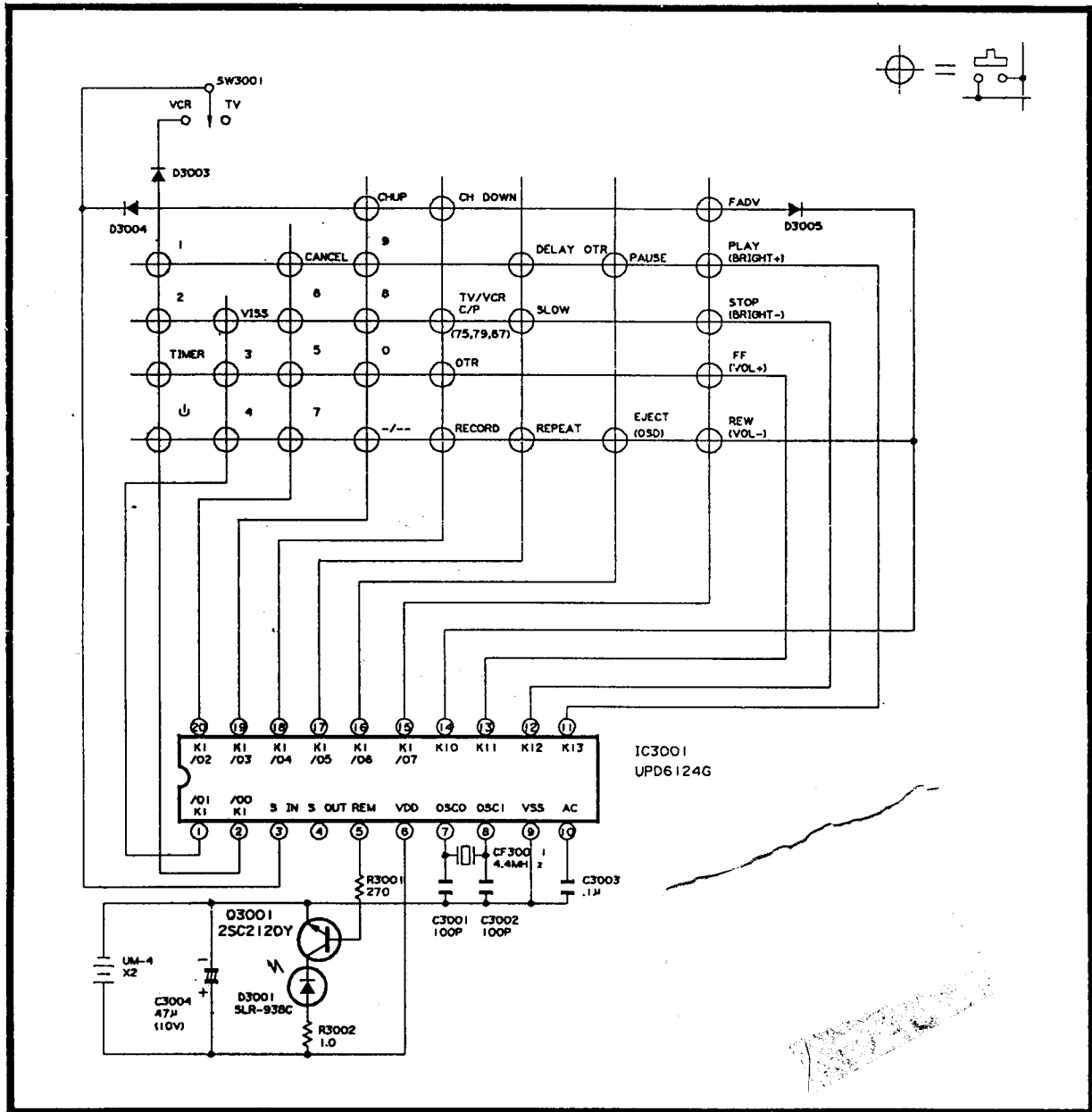

GLOSSARY

	Abbreviation			Abbreviation		
A	ABSS	Auto Blank Section Scan	J	J.K.F-F	J.K.Flip-Flop	
	AFC	Automatic Frequency Control	K	KE	Key Entry	
	AFT	Automatic Fine Tuning	L	LED	Light Emitting Diode	
	AGC	Automatic Gain Control		LDM	Loading Motor	
	ALC	Automatic Level Control		LPF	Low Pass Filter	
	APC	Automatic Phase Control		LP	Long Play	
	AD	Address	M	MIC	Microphone	
	AL	After Loading		MM	Mono-multi Vibrator	
	ACL	All Clear	N	NC	Non Connection	
	AT	All Time		NS (N/S)	Normal Speed	
AV (A/V)	Audio/Video	O	OSC	Oscillator		
A-Mute	Audio Mute					
C	CAP	Capstan	P	PAD	Power Assisted Drive	
	CAP.M.	Capstan Motor		PAM	Pulse Amplitude Modulation	
	C.FG	Capstan Frequency Generator		PCM	Pulse Code Modulation	
	C.PG	Capstan Pulse Generator		PDM (PWM)	Pulse Count Modulation	
	CST	Cassette			Pulse Duration Modulation	
	CST.M.	Cassette Motor		Pulse Width Modulation		
	CSA	Cassette Switch-A		PFM	Pulse Frequency Modulation	
	CSB	Cassette Switch-B		PPM	Pulse Phase Modulation	
	CSD	Cassette Switch-D		PB	Playback	
	CH	Channel		PG	Phase Generator	
CTL	Control	PR	Pinch Roller			
D	D.D.	Direct Drive	PWB	Printed Wiring Board		
	D.F.F.	D-Flip-Flop	R	REC	Record	
	DM	Drum Motor		REM (R/C)	Remote Control	
	D.FG	Drum Frequency Generator		REV	Reverse	
	D.PG	Drum Pulse Generator		REW	Rewind	
	D.TPG	Drum Trapezoidal Generator		RF	Radio Frequency	
	DET	Detector	S	S/H	Sample and Hold	
	DUB	Dubbing		SN	Signal to Noise	
		SP		Standard Play		
E	EE	Electric to Electric	SS	Start Sensor		
	EF	Emitter Follower	SSVM	Solid State Voltmeter		
	EP	Extended Play	STILL-H	Still Mode High Level		
	ES	End Sensor	SUP-REEL	Supply Reel		
			SW	Switch/Switching		
	F	F-ADV-P	Frame Advance Pulse	T	TPG	Trapezoidal Generator
		FWD	Forward		TU-REEL	Take-up Reel
F/R		Forward/Reverse	U	UL	Unloading	
FF		Fast Forward		UR	Un regulated	
FM		Frequency Modulation		V	VCO	Voltage Controlled Oscillator
F.G.		Frequency Generator			VCR	Voltage Controlled Resistor
F.E.		Full Erase			V-MUTE	Video Mute
FV	False Vertical Sync.	V-LOCK	Vertical Lock for False Vertical Sync Signal			
H	HIFI	High Fidelity	VS (PS)	Video Search (Picture Scan)		
	HPA	High Pass Amplifier	VSF	Video Search Forward		
	HPF	High Pass Filter	VSR	Video Search Reverse		
	HS (H/S)	Half Speed	VTVM	Vacuum Tube Voltmeter		
	HSP	Head Switching Pulse				
H. SYNC	Horizontal Sync.					
I	ID	Identical Amplifier				
	IF	Intermediate Frequency				

SPARE PARTSLIST VR6448/67SFRONT PANEL PARTS

1	4822	443	40695	FRONT PANEL ASS'Y
2	4822	410	26709	STANDBY BUTTON ASS'Y
2-1	4822	462	71544	LED COVER, STANDBY
2-2	4822	410	26713	STANDBY BUTTON
3	4822	443	62573	DOOR ASS'Y
3-1	4822	443	62575	DOOR
3-2	4822	459	10835	BADGE "PHILIPS"
3-3	4822	403	53525	DOOR ANGLE
4	4822	432	30298	COVER
5	4822	454	20869	FRONT DECORATION
6	4822	454	20871	INDIC PLATE, TIMER
7	4822	454	20872	INDIC PLATE, LED
8	4822	443	40696	FRONT PANEL
9	4822	410	26711	BUTTON, PLAY/STOP
10	4822	410	26712	BUTTON, FF/REWIND
11	4822	410	26714	BUTTON, EJECT
12	4822	410	26715	BUTTON, COUNTER
13	4822	410	26716	BUTTON, RECORD
14	4822	410	26717	BUTTON, CHANNEL
15	4822	410	26719	BUTTON, SIMUL
16	4822	417	41015	MAGNET
17	4822	492	70057	SPRING
18	4822	450	61278	TIMER FILTER
19	4822	290	80819	EARTH SPRING A
20	4822	290	80821	EARTH SPRING B
21	4822	410	26718	BUTTON, TIMER

MECHANICAL PARTS

601	4822	464	50732	MAIN FRAME
602	4822	443	30735	UPPER CABINET
603	4822	443	51137	BOTTOM PLATE
604	4822	443	62574	ANT TERM COVER
607	4822	255	70244	Y/C HOLDER
608	4822	403	53552	EARTH PLATE
609	4822	492	42285	EARTH SPRING
610	4822	502	12542	SCREW
611	4822	502	11774	SCREW
612	4822	502	13157	SCREW
613	4822	502	11781	SCREW
614	4822	502	12993	SCREW, UPPER CABINET
615	4822	255	40802	LED HOLDER, POWER
617	4822	256	91274	DISPLAY HOLDER
619	4822	256	91343	TUNER HOLDER
620	4822	462	71545	SPACER

MISCELLANEOUS

4822	218	30451	I.R. remote control
4822	736	51522	Directions for use

PWB-A MAIN CIRCUIT

Q 701	4822	130	61272	2SC2412KQ
Q 702	4822	130	61272	2SC2412KQ
Q 703	4822	130	61272	2SC2412KQ
Q 704	4822	130	60145	DTC124EK
Q 705	4822	130	61269	2SA1037KQ
Q 706	4822	130	60145	DTC124EK
Q 707	4822	130	60557	DTA124EK
Q 708	4822	130	61269	2SA1037KQ
Q 709	4822	130	61269	2SA1037KQ
Q 710	4822	130	61268	DTC114EK
Q 711	4822	130	61268	DTC114EK
Q 801	4822	130	61272	2SC2412KQ
Q 802	4822	130	61272	2SC2412KQ
Q 803	4822	130	61272	2SC2412KQ
Q 804	4822	130	60258	2SC2001LK
Q 951	4822	130	60768	2SA988
Q 952	4822	130	60767	2SA1013
Q 953	4822	130	60151	2SB1117KU
Q 954	4822	130	60146	DTC144EK
Q 955	4822	130	60151	2SB1117KU
Q 956	4822	130	60146	DTC144EK
Q 957	4822	130	61272	2SC2412KQ
Q 1451	4822	130	42803	2SC383-WT
Q 2201	4822	130	61272	2SC2412KQ
Q 4401	4822	130	61269	2SA1037KQ
Q 5501	4822	130	61272	2SC2412KQ
Q 6601	4822	130	60146	DTC144EK
Q 6602	4822	130	61273	2SD1757KS
Q 6603	4822	130	61273	2SD1757KS
Q 6604	4822	130	60326	DTA144EK
Q 8801	4822	130	61271	2SA1271-Y
Q 8802	4822	130	60941	DTA114EK
Q 8804	4822	130	61271	(VR6448/67)
Q 8805	4822	130	61271	(VR6448/67)
Q 8809	4822	130	60941	DTA114EK

INTEGRATED CIRCUITS

IC 701	4822	209	73469	
IC 702	4822	209	72574	BA1521BN
IC 801	4822	209	73471	
IC 802	4822	209	72768	
IC 803	4822	209	73474	
IC 804	4822	209	73476	
IC 951	4822	209	72022	UPC574JT
IC1451	4822	209	72771	
IC2201	4822	209	72016	BA7021
IC5501	4822	209	82553	BA7007

DIODES

D 701	4822	130	80969	1N4531
D 702	4822	130	80969	1N4531
D 703	4822	130	80969	1N4531
D 704	4822	130	80969	1N4531
D 707	4822	130	80988	HZS2C3/TA
D 708	4822	130	80969	1N4531
D 709	4822	130	80969	1N4531
D 710	4822	130	80969	1N4531

D 712	4822	130	80969	1N4531
D 801	4822	130	80969	1N4531
D 804	4822	130	80969	1N4531
D 805	4822	130	80411	ERA1502
D 954	4822	130	80411	ERA1502
D 952	4822	130	80413	HZS6.2EB3
D 953	4822	130	80493	HZS5.6EB1
D 955	4822	130	80416	HZS33EB3
D 956	4822	130	80969	1N4531
D 957	4822	130	80969	1N4531
D 959	4822	130	31919	RD5.6EB
D 5501	4822	130	80969	1N4531
D 5502	4822	130	80969	1N4531
D 5503	4822	130	80969	1N4531

COILS AND FILTERS

L 1451	4822	157	10232	12UH
L 4401	4822	157	10135	220UH
L 5501	4822	156	40881	220UH
L 5503	4822	157	10218	15MH
FL 801	4822	242	72279	
FL5501	4822	154	10048	

CONTROLS

R 736	4822	100	11219	100K(B), SLOW/STILL
R 740	4822	100	11219	100K(B), PHASE GEN M
R 828	4822	100	11189	100K(B), FALSE VERT

CAPACITORS

C 702	4822	124	41037	1.0UF, 50V, ELECTR
C 712	4822	124	41037	1.0UF, 50V, ELECTR
C 713	4822	121	51246	0.1UF, 50V, METAL PO
C 715	4822	124	22623	2.2UF, 50V, ELECTR
C 719	4822	124	90372	100UF, 6.3V, ELECTR
C 726	4822	121	51246	0.1UF 50V METAL POL
C 727	4822	121	51363	0.047UF, 50V, METAL
C 728	4822	124	90372	100UF, 6.3V, ELECTR
C 732	4822	122	33264	.1UF, 25V, CERAMIC
C 733	4822	124	41036	10UF, 16V, ELECTR
C 736	4822	121	90043	4.7UF, 5V, ELECTR
C 738	4822	122	33264	.1UF, 25V, CERAMIC
C 739	4822	121	51364	0.39UF< 50V< METAL
C 743	4822	124	22486	47UF, 10V, ELECTR
C 814	4822	124	41037	1.0UF, 50V, ELECTR
C 1452	4822	121	51365	0.33UF, 50V, METAL P
C 1453	4822	121	51246	0.33UF 50V METAL POL
C 1564	4822	124	40866	100UF 16V ELECTR
C 2201	4822	124	41037	1.0UF, 50V, ELECTR
C 4401	4822	124	40866	100UF, 16V, ELECTR
C 4403	4822	124	41302	470UF, 6.3V, ELECTR
C 5556	4822	124	40866	100UF, 16V, ELECTR
C 8801	4822	124	90382	220UF, 10V, ELECTR

MISCELLANEOUS

4822	214	32308	IF pack
4822	214	32307	RF converter
4822	264	30251	Jack Audio/Video in
4822	267	20245	Plug 2 pins (TP2201)
4822	265	40331	Plug 3 pins (AC)
4822	265	30232	Plug 4 pins (AU)
4822	265	40507	Plug 5 pins (AA,AB)
4822	264	50185	Plug 6 pins (AX,AY)
4822	265	40746	Plug 10 pins (AW,AV)
4822	267	40805	Socket Female 6 pins (AT)
4822	267	50794	Socket Female 10 pins (AP)
4822	267	50847	Socket Female 12 pins
4822	267	50848	Socket Female 13 pins
4822	267	60241	Socket Female 27 pins (AM)

PWB-B LUMINANCE/CROMINANCE CIRCUITTRANSISTORS.

Q201	4822	130	60146	DTC144EK
Q202	4822	130	42594	DTC144ES
Q203	4822	130	61269	2SA1037KQ
Q205	4822	130	60146	DTC144EK
Q501	4822	130	60258	2SC2001L
Q502	4822	130	61272	2SC2412KQ
Q503	4822	130	61272	2SC2412KQ
Q504	4822	130	61272	2SC2412KQ
Q505	4822	130	61272	2SC2412KQ
Q507	4822	130	60148	2SA933
Q3301	4822	130	60147	2SC1740SQT
Q3302	4822	130	61272	2SC2412KQ

INTEGRATED CIRCUITS

IC201	4822	209	73467	
IC401	4822	209	83522	AN3320K
IC501	4822	209	72478	TA8644N/-1

DIODES AND CRYSTAL

IC201	4822	130	80969	1N4531
IC202	4822	130	80969	1N4531
IC203	4822	130	80969	1N4531
IC204	4822	130	80969	1N4531
IC205	4822	130	33716	MTZ5.1A
IC501	4822	130	80552	HZS6A3/TA
IC503	4822	130	80969	1N4531
IC504	4822	130	80969	1N4531
X501	4822	242	70337	CRYSTAL

CAPACITORS

C203	4822	124	41038	3.3UF, 50V, 20% ELEC
C218	4822	121	51357	022UF, 50V, METAL.PO
C224	4822	121	51363	0.047UF, 50V, METAL.
C225	4822	124	90382	220UF, 10V, 20% ELEC
C230	4822	121	42333	0.1UF, 63V, METAL.
C240	4822	124	90381	100UF, 6.3UV 20%

COILS AND FILTERS

L201	4822	157	10135	220UH
L401	4822	157	10271	68UH
L402	4822	157	10266	120UH
L403	4822	157	10231	100UH
L404	4822	157	10271	68UH
L405	4822	157	10267	15UH
L501	4822	157	53278	18UH
L502	4822	157	10269	39UH
L503	4822	157	10276	220UH
L504	4822	157	10276	220UH
L505	4822	157	10264	560UH
L3301	4822	157	10274	150UH
L3302	4822	157	10271	68UH
L3303	4822	157	10274	150UH
L3304	4822	157	10135	220UH
DL401	4822	158	10741	DELAY LINE
DL501	4822	320	40143	DELAY LINE
FL201	4822	157	53147	FILTER
FL501	4822	157	52771	FILTER
FL502	4822	157	53148	FILTER

CONTROLS

R201	4822	100	11279	47K(B), EE LEVEL
R220	4822	100	11278	10K(B), DEVIATION
R222	4822	100	11396	20K(B), CARRIER
R224	4822	100	11279	47K(B), DARK CLIP
R225	4822	100	11279	47K(B), WHITE CLIP
R414	4822	100	11279	47K(B), PLAYB.LEVEL
R506	4822	100	11237	100K(B), APC
R518	4822	100	11239	2.2K(B), REC.COL.LEV
R3304	4822	100	11238	1K(B), RECORD FM

MISCELLANEOUS

4822	264	40246	Plug 3 pins (CF)
4822	265	40744	Plug 8 pins (CE)
4822	267	50788	Socket 6 pins (CC CD)
4822	267	50846	Socket 10 pins (CA CB)

PWB-X HEAD AMPLIFIER CIRCUITTRANSISTORS

Q 301	4822	130	60903	2SC2059K
Q 302	4822	130	61272	2SC2412

INTEGRATED CIRCUITS

IC 301	4822	209	72468	BA7252S
--------	------	-----	-------	---------

CAPACITORS

C 302	4822	121	42333	0.1UF, 63V METAL POLY
C 305	4822	121	42333	0.1UF, 63V METAL POLY
C 309	4822	121	51204	0.047UF, 63V MET:POLY

COILS

L 303	4822	157	10141	100UH
L 304	4822	157	10271	68UH
L 305	4822	157	53154	33UH
L 306	4822	157	53154	33UH
L 307	4822	157	10234	22UH
L 309	4822	157	10274	150UH

MISCELLANEOUS

4822	265	30331	Plug 2 pins (TP 301 302)
4822	265	30573	Plug 8 pins (XA)
4822	267	40804	Socket 5 pins (ZA)

PWB-T TIMER CIRCUITTRANSISTORS

Q5001	4822	130	61276	2SC4038
Q5002	4822	130	61278	2SC1561
Q5003	4822	130	61274	DTC144
Q5004	4822	130	60154	2SK118GR

INTEGRATED CIRCUITS

IC5001	4822	209	73472
IC5002	4822	209	73447
IC5003	4822	209	73475

DIODES AND CRYSTAL

D5001	4822	130	80969	1N4531
D5002	4822	130	80969	1N4531
D5003	4822	130	80969	1N4531
D5004	4822	130	80969	1N4531
D5005	4822	130	80969	1N4531
D5006	4822	130	80969	1N4531
D5007	4822	130	80969	1N4531
D5008	4822	130	80969	1N4531
D5009	4822	130	80969	1N4531
D5010	4822	130	80969	1N4531
D5011	4822	130	80969	1N4531
D5012	4822	130	80969	1N4531
D5013	4822	130	80969	1N4531
D5016	4822	130	80969	1N4531
D5017	4822	130	80969	1N4531
D5019	4822	130	80969	1N4531
D5020	4822	130	80969	1N4531
D5021	4822	130	80969	1N4531
D5023	4822	130	80969	1N4531
D5024	4822	130	80969	1N4531
D5025	4822	130	80549	HZS9.1EB2
D5026	4822	130	80969	1N4531
D5029	4822	130	80969	1N4531
X5001	4822	242	72283	CRYSTAL

FILTER

FL5001	4822	242	72251
--------	------	-----	-------

TRIMMER

C5004	4822	125	50366	TRIMMER
-------	------	-----	-------	---------

MISCELLANEOUS

DG5001	4822	130	90586	FLUORES. DISPLAY TUBE
SW5001	4822	276	12216	SWITCH, CLOCK
SW5002	4822	276	12216	SWITCH, TIMER
SW5003	4822	276	12216	SWITCH, (+)
SW5004	4822	276	12216	SWITCH, (-)
SW5005	4822	276	12216	SWITCH, MOD CHANGE
SW5006	4822	276	12216	SWITCH, OTR START
SW5007	4822	276	12216	SWITCH, COUNT. MEMORY
SW5008	4822	276	12216	SWITCH, CANCEL
SW5010	4822	276	12216	SWITCH, ALL CLEAR
SW5011	4822	276	12216	SWITCH, OTR STOP
SW5012	4822	276	12216	SWITCH, REWIND
SW5013	4822	276	12216	SWITCH, PLAYBACK
SW5014	4822	276	12216	SWITCH, STOP
SW5015	4822	276	12216	SWITCH, FAST FORWARD
SW5016	4822	276	12216	SWITCH, RECORD
SW5017	4822	276	12216	SWITCH, PAUSE
SW5018	4822	276	12477	SWITCH, VHF/UHF
SW5019	4822	276	12216	SWITCH, MANUAL TUN
SW5020	4822	276	12216	SWITCH, MANUAL TUN
	4822	267	20245	Plug 2 pins (TP5001)
	4822	265	40745	Plug 7 pins (TD)
	4822	276	40408	Socket 6 pins (TA)
	4822	267	50849	Socket 13 pins (TB)
	4822	218	20829	Infrared remote control receiver

PWB-H OPERATION CIRCUITDIODES

D 8101	4822	130	80417	LED, STANDBY
D 8102	4822	130	80969	1N4531
D 8103	4822	130	80969	1N4531

CAPACITORS

C 8101	4822	124	22615	.047, 5.5V, ELECTR
--------	------	-----	-------	--------------------

MISCELLANEOUS

SW8101	4822	276	12216	SWITCH, EJECT
SW8102	4822	276	12216	SWITCH, STANDBY
SW8103	4822	276	12474	SWITCH, AUTO/COLOUR
SW8104	4822	276	12216	SWITCH, TRACK (+)
SW8105	4822	276	12216	SWITCH, TRACK (-)
SW8106	4822	276	12216	SWITCH, SIMUL

PWB-P POWER CIRCUITTRANSISTOR

INTEGRATED CIRCUITS

IC 901	4822 209 72481	PQ09R05
--------	----------------	---------

DIODES

D 901	4822 130 80205	11E1
D 902	4822 130 80205	11E1
D 903	4822 130 80205	11E1
D 904	4822 130 80205	11E1
D 905	4822 130 32424	1SS55
D 906	4822 130 80989	RD12ESB2
D 907	4822 130 80991	RD2.0ESB2
D 908	4822 130 80205	11E1
D 909	4822 130 80205	11E1
D 910	4822 130 80205	11E1
D 911	4822 130 80205	11E1
D 912	4822 130 33721	ERA15-02

CAPACITORS

C 902	4822 124 41432	2200UF, 35V, ELECTR
C 905	4822 124 41432	2200UF, 35V, ELECTR
C 906	4822 124 41274	47UF, 100V, ELECTR

RESISTORS

R 901	4822 116 53279	12M OHM, 1/2W, SOLID
R 904	4822 116 80898	.22 OHM, FUSIBLE RES
R 905	4822 116 80905	22K OHM, 1/4W
R 906	4822 116 80906	2.2K OHM, 1/4W
PR 901	4822 116 90452	6.8 OHM THERMISTOR

TRANSFORMER

T 901	4822 146 21366	PT2492
-------	----------------	--------

MISCELLANEOUS

	4822 321 10525	Mains cord
F 901	4822 253 30222	FUSE, T1A/250V
F 902	4822 253 30223	FUSE, T1A/250V
	4822 265 30223	Plug 3 pins (OA)
	4822 265 40748	Plug 10 pins (PA)
	4822 265 30638	Plug 3 pins (PB)

INFRARED REMOTE CONTROLTRANSISTORS

Q 3001	4822 130 42292	2SC2120Y
--------	----------------	----------

INTEGRATED CIRCUIT

IC3001	4822 209 73473	UPD6124G
--------	----------------	----------

D 3001	4822	130	80421	LED, SLR-938C
D 3003	4822	130	80992	1SS270
D 3004	4822	130	80992	1SS270
D 3005	4822	130	80992	1SS270
CF3001	4822	242	72284	OSCIL CBS440EB1 4.4
SW3001	4822	276	12476	SWITCH, VCR/TV

CABINET PARTS

4822	432	30316	Upper cabinet
4822	443	51133	Lower cabinet
4822	443	62197	Battery cover
4822	454	20862	Indication plate
4822	411	61537	Slider knob
4822	410	26697	Rubber key
4822	242	71848	Infrared filter
4822	290	80777	Battery terminal +
4822	290	80778	Battery terminal -
4822	290	80776	Battery terminal +/-
4822	502	12927	Screw

PWB-C AUDIO CIRCUITTRANSISTOR

Q 602	4822	130	61275	2SC3939R
-------	------	-----	-------	----------

INTEGRATED CIRCUIT

IC 601	4822	209	73482	BA7765S
--------	------	-----	-------	---------

CAPACITORS

C 610	4822	124	40905	100UF 10V ELECTR.
C 623	4822	124	22622	0.0056UF 500V POLY
C 627	4822	124	41037	1UF 50V ELECTR.

COILS AND TRANSFORMERS

L 601	4822	157	10221	8.2MH
L 602	4822	157	53645	220UH
T 601	4822	146	21365	

CONTROLS

R 610	4822	100	11397	10K(B) PLAYBACK LEVEL
R 630	4822	100	11398	470K(B) BIAS

MISCELLANEOUS

4822	265	30331	Plug 2 pins (TP601,602)
4822	265	40747	Plug 7 pins (K601,602)

MECHANICAL CHASSIS PARTS

1	4822	528	90691	RETAINING GUIDE
2	4822	492	70049	RET GUIDE SPRING
3	4822	403	53507	HALF-LOADING LEVER

5	4822	403	53512	HALF-LOAD DRIVE LEV
6	4822	492	70059	HALF-LOAD REC SPRING
7	4822	403	53511	HALF-LOAD REC LEV
8	4822	492	70052	AZIMUTH SPRING
9	4822	249	10371	A C HEAD ASS'Y
10	4822	462	71543	RET GUIDE CAP
11	4822	466	10565	A C HEAD PWB
12	4822	464	50731	A HEAD ARM
13	4822	492	42284	A C HEAD ARM SPRING
14	4822	464	50729	LOADING BLOCK HOLDER
15	4822	466	10564	LOADING BLOCK PWB
16	4822	361	21158	LOADING MOTOR
17	4822	267	40806	PLUG, 5 PIN (MG)
18	4822	276	12482	CAM SWITCH
19	4822	522	10405	WORM WHEEL
20	4822	528	50297	LOADING MOTOR PULLEY
21	4822	358	30876	LOADING BELT
22	4822	522	10404	WORM ASS'Y
23	4822	535	92515	WORM SHAFT
24	4822	522	32496	MASTER CAM
25	4822	403	53509	PINCH ROLLER LEVER
26	4822	403	53513	RELAY SHIFTER LEVER
27	4822	403	53508	REVERSE GUIDE
28	4822	492	42283	REVERSE GUIDE SPRING
29	4822	361	60468	CAPSTAN D.D. MOTOR
30	4822	403	53516	SLOW BRAKE LEVER
31	4822	492	70056	SLOW BRAKE SPRING
32	4822	492	70053	REVERSE GUIDE SPRING
33	4822	403	53533	RELEY GEAR DRIVE LEV
34	4822	403	53517	BRAKE SHIFTER
35	4822	535	92514	BRAKE LOCK SHAFT
36	4822	492	70051	ABS PLATE SPRING
37	4822	492	70055	VIDEO SEARCH SPRING
38	4822	403	53514	BRAKE LEVER V.S.
39	4822	403	53515	RECIPROCATING LEVER
40	4822	281	50125	BRAKE SOLONOID
41	4822	528	81242	TAKE-UP REEL DISK
42	4822	522	32497	IDLER GEAR
43	4822	522	32498	REEL PULLEY
44	4822	492	42282	SHIFTER SPRING
45	4822	403	53518	SHIFTER SPRING COVER
46	4822	255	40885	CASSETTE LED HOLDER
47	4822	130	80994	CASSETTE LED
48	4822	214	32319	REEL SENSOR PWB
49	4822	130	10034	REEL SENSOR
50	4822	464	50728	REEL BLOCK CHASSIS
51	4822	403	53539	TENSION ADJ LEVER
52	4822	403	53538	TENSION REL LEVER
53	4822	403	53537	BACK TENSION LEVER
54	4822	492	70063	SPRING, FAST FORWARD
55	4822	528	81243	SUPPLY REEL DISK
56	4822	492	70062	MAIN BRAKE SPRING
57	4822	403	53541	INTERMEDIATE LEVER
58	4822	403	53536	TAKE-UP BRAKE LEVER
59	4822	403	53535	SUPPLY BRAKE LEVER
60	4822	522	32502	LOADING RELAY GEAR
61	4822	492	70061	LOADING REC SPRING
62	4822	522	32501	TAKE-UP LOADING GEAR
63	4822	403	53532	TAKE-UP LOADING ARM

65	4822	403	53531	SUPPLY LOADING ARM
66	4822	464	50733	MAIN CHASSIS
67	4822	401	11196	TENSION BAND
68	4822	403	53553	TENS SPRING HOOK PLA
69	4822	492	70064	TENSION SPRING
70	4822	403	53534	TENSION ARM
72	4822	403	53551	POLE BASE SLIDER
73	4822	403	53528	T POLE BASE
74	4822	528	90693	GUIDE ROLLER
75	4822	403	53549	SUP POLE BASE SLIDER
76	4822	403	53527	SUPPLY POLE BASE
77	4822	462	30398	TAKE-UP LOADING RAIL
78	4822	462	30399	SUPPLY LOADING RAIL
79	4822	528	90694	SUPPLY IMP ROL INN
80	4822	528	90695	SUPPLY IMP ROL FLANG
81	4822	528	90692	SUPPLY IMP ROLLER
82	4822	249	40246	FULL ERASE HEAD
83	4822	466	10566	FULL ERASE HEAD PWB
84	4822	290	80817	CASS CONT EARTH SPRI
85	4822	358	30877	REEL BELT
86	4822	403	53548	AUX F F BRAKE LEVER
87	4822	492	70069	AUX F F BRAKE SPRING
89	4822	691	20353	UPPER DRUM
90	4822	464	50739	DRUM BASE
91	4822	691	20478	LOWER DRUM
92	4822	290	80818	EARTH BRUSH
93	4822	361	60469	DRUM D.D. MOTOR
94	4822	403	53302	HEATER ANGLE
95	4822	209	72578	TRANSISTOR HEATER
96	4822	321	22937	FLAT CABLE (DRUM D.D
97	4822	321	22938	FLAT CABLE (CAPSTAN
98	4822	403	53526	FLAT CABLE HOLDER
99	4822	403	52542	DEW SENSOR
100	4822	267	40807	SOCKET, 5 PIN (MF)
101	4822	116	90456	220 OHM, 1/4W, 5%, O
102	4822	122	32397	.001UF, 50V, 10%, DI
103	4822	111	90699	47K OHM, 1/16W, 5%,
104	4822	462	71551	RELEASE PIN CAP
105	4822	403	53519	REEL DISK CATCH HOLD
106	4822	532	81093	SUPPLY IMP.FLANGE

CASSETTE HOUSING CONTROL PARTS

301	4822	443	62576	CASSETTE COVER
302	4822	464	50741	DOWN GUIDE
303	4822	276	12483	ERASE PROT SWITCH
304	4822	464	50734	HOUSING FRAME (RIGHT
305	4822	403	53529	CASSETTE COVER ARM
306	4822	522	32506	PHASE GEAR
307	4822	492	42286	DRIVE GEAR SPRING
308	4822	522	32504	DRIVE GEAR (RIGHT)
309	4822	492	70065	RECIPROCATING SPRING
310	4822	522	32503	WORM WHEEL GEAR
311	4822	403	53547	OPEN LEVER
312	4822	492	42289	OPEN LEVER SPRING
313	4822	403	53546	SWITCHING LEVER
314	4822	492	70067	SWITCHING LEV SPRING
315	4822	276	12484	CASSETTE SWITCH
316	4822	403	53522	WORM BRACKET

DIODES AND CRYSTAL

318	4822	535	80789	WORM SHAFT
318-1	4822	522	32507	WORM
318-2	4822	535	80789	WORM SHAFT
318-3	4822	528	20623	CLUTCH
318-4	4822	528	20624	COUPLING
319	4822	403	53545	CLUTCH LOCK LEVER
320	4822	492	70066	CLUTCH LOCK LEV SPR
321	4822	403	53544	CLUTCH RELEASE LEV
322	4822	492	70058	CLUTCH REL LEV SPRIN
323	4822	403	53543	CLUTCH LEVER
324	4822	528	50298	PULLEY
325	4822	358	30878	CASSETTE LOADING BEL
326	4822	403	53521	UPPER PLATE
327	4822	464	50737	SLIDER HOLDER L
328	4822	492	41391	CASSETTE SPRING
329	4822	403	53524	SLIDER LOCK L
330	4822	492	70068	SLIDER LOCK SPRING
331	4822	464	50738	SLIDER
332	4822	403	53542	LOCK RELEASE LEVER
333	4822	492	42291	LOCK REL LEV SPRING
334	4822	462	71546	SLIDER LOCK COVER
335	4822	403	53523	SLIDER LOCK R
336	4822	464	50736	SLIDER HOLDER R
337	4822	522	32505	DRIVE GEAR L
338	4822	492	42287	DRIVE GEAR SPRING L
339	4822	464	50735	HOUSING FRAME L
340	4822	535	92516	MAIN SHAFT
341	4822	492	42288	CASS COVER SPRING
342	4822	214	32326	START SENSOR PWB
343	4822	214	32327	END SENSOR PWB
344	4822	130	32491	PHOTOTRANSISTOR
345	4822	130	42277	TRANSISTOR
346	4822	267	40808	SOCKET, 5 PIN
347	4822	116	52693	15K OHM, 1/4W, 5%, C
348	4822	116	53278	22K OHM, 1/4W, 5%, C
349	4822	116	52269	3.3K OHM, 1/8W, 5%,
350	4822	116	52283	4.7K OHM, 1/8W, 5%,
351	4822	116	52233	10K OHM, 1/8W, 5%,
352	4822	124	21916	.047UF, 25V, 20%, CE
401	4822	502	12986	CUT WASHER (4.2W-6.0
402	4822	502	13153	SCREW (B TIGHT BTN3P

FIXING MATERIAL

201	4822	505	10934	ADJUSTING NUT
202	4822	532	52045	WASHER W2.6S-6-0.5
203	4822	532	11125	E RING-2
204	4822	502	13165	AC HEAD SCREW
205	4822	502	13155	AZIMUTH ADJ SCREW
206	4822	502	13148	TILT ADJUSTING SCREW
207	4822	505	10936	ADJUSTING NUT (A/C H
208	4822	532	11136	WASHER W3.1-5.4-0.5
209	4822	532	52038	WASHER W2.6-6-0.5 (L
210	4822	502	13158	SCREW C2.6P+6S
211	4822	530	70455	E RING-3
212	4822	532	52044	WASHER PSW4.6-6-0.25
213	4822	505	10935	ADJ NUT (X-POSITON)
215	4822	532	52039	WASHER CW2.7-7-0.5
215	4822	532	11239	WASHER CW 2.7-7-0.5

217	4822	502	11752	SCREW 2.6P+35
218	4822	530	80261	WASHER CW2.5-5.4-0.5
219	4822	532	11126	E RING-2.5
220	4822	532	52043	WASHER W2.5-5-0.5
221	4822	532	52041	WASHER W2.6-5-0.13
222	4822	532	52042	WASHER W2.6-5-0.25
223	4822	502	13151	SCREW W2.6P+6S
224	4822	502	13149	SCREW WSW2P+11S
225	4822	502	13154	SCREW M2X4
226	4822	502	13159	SCREW C2.6P+8S
227	4822	502	13162	B TIGHT SCREW C2.6P+
228	4822	502	11783	SCREW C3P+8S
229	4822	532	52037	WASHER CW2.5-6-0.5
230	4822	502	13161	B TIGHT SCREW 2P+6S
231	4822	502	11842	SCREW W3P+9S-NI
232	4822	502	13152	SCREW S3P+8A-6W
233	4822	502	13164	SCREW SW8P+6S-NI
234	4822	502	13156	SCREW SW2.6P+12S
235	4822	502	11755	SCREW SW3P+5S
236	4822	502	11757	SCREW S3P+6S
237	4822	502	11776	SCREW S3P+8S
238	4822	530	70455	E RING-3 (CURL)
239	4822	532	52039	WASHER CW2.7-7-0.5
240	4822	532	52047	WASHER 3.1-5.4-0.25
241	4822	532	52048	C/S WASHER

SERVICE TOOLS

4822	395	80215	Reel disc height adjustment
4822	395	80193	Master plane jig
4822	395	80301	A/C head tilt adjustment
4822	395	80196	Torque gauge 909
4822	395	80197	Torque gauge 1,2 kg.
4822	395	80198	Gauge head
4822	395	80217	Cass. torque meter
4822	395	80194	Tension gauge 300 gr.
4822	395	80216	Tension gauge 2 kgr.
4822	395	80189	Hex wrench 0.9 mm
4822	395	80191	Hex wrench 1.2 mm
4822	395	80192	Hex wrench 1.5 mm
4822	397	30107	Aligment tape PAL
4822	395	80186	Drum replacing jig
4822	395	80213	Tension gauge adapter
4822	395	50189	Special screw driver
5322	395	54047	Torque screw driver
4822	395	50192	Box driver
4822	395	50273	Box driver
4822	395	80302	Ret guide height adjustment
4822	395	80303	Rev guide height adjustment

Service Information

1990-05-08

VR6448 VR6349
VIDEO CASSETTE RECORDER VR6548 VR6449
VR6648 VR6549

VR.O.S.-90-06

Phenomenon:

- The cassette can not be ejected.
- Intermittent no operation of the VCR.
- The VCR does not go into the "eject" mode.
- Threading car tangled by the tape tension stabilizer.

Cause: The synchronisation of the threading car 76, the brake shifter 34 and the tape tension stabilizer 70 is lost due to excessive wear of the tension adjusting lever 51. (see fig.1)

Solution: From the production Oct. 1989 a new model tension adjusting lever has been used. (see fig.2). The contact surface of the new tension adjusting lever has been enlarged by changing it from cylindrical into oval.

Service solution: Replace the tension adjusting lever by a new model lever.
Under codenumber 4822 403 53539 PCE will supply the new model lever.

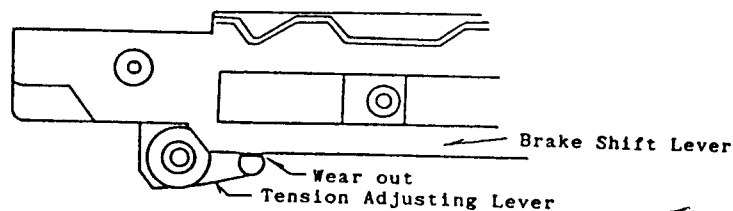

Fig.1

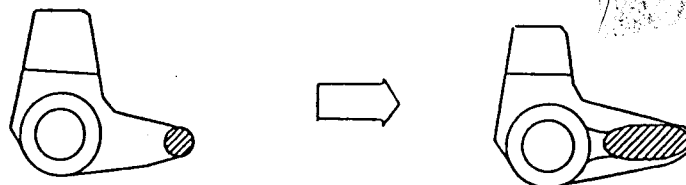

Fig.2

Phenomenon:

- Much noise or only noise in the picture during Play-back.
- Intermittent noise in the picture, difficult to reproduce.

Cause: Bad ground contact between the interconnecting CBA and the chassis. This CBA connects the rotating transformer with the Head amplifier.
If a bad ground contact is present, the Head amplifier may oscillate and produce noise.

Service solution:

- Remove the 2 screws 232. (fig.3)
- Add 2 3.0 mm. spring washers 4822 530 80082.
- Tighten the screws 232 with 9-10 kg.cm. (0.9-1 Nm)

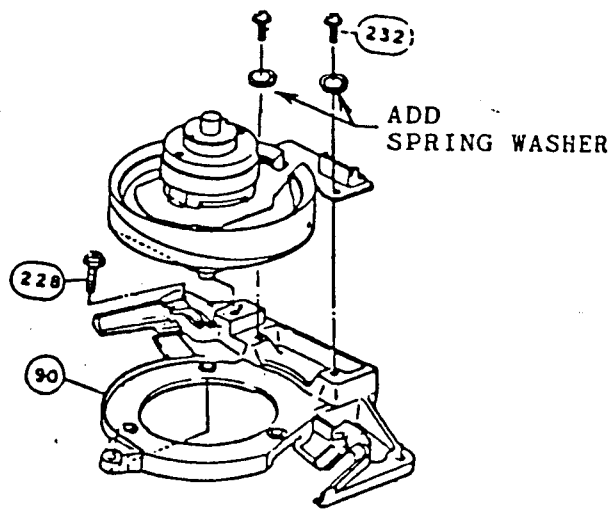

Fig.3

Service Information

1990-02-21

VIDEO CASSETTE RECORDER VR6448
VR6548

VR.O.S.-90-02

To improve the performance, the following parts have been changed in the undermentioned sets :

A In PWB-T Timer circuit :

FL5001 Filter has been changed into 4822 242 72273
C5020 330pF 50V 10% ceramic has been added
4822 126 10799

B In PWB-A Main circuit :

C1470 0.001 μ F 50V 10% ceramic has been added
4822 126 10798
C1471 0.001 μ F 50V 10% ceramic has been added
4822 126 10798

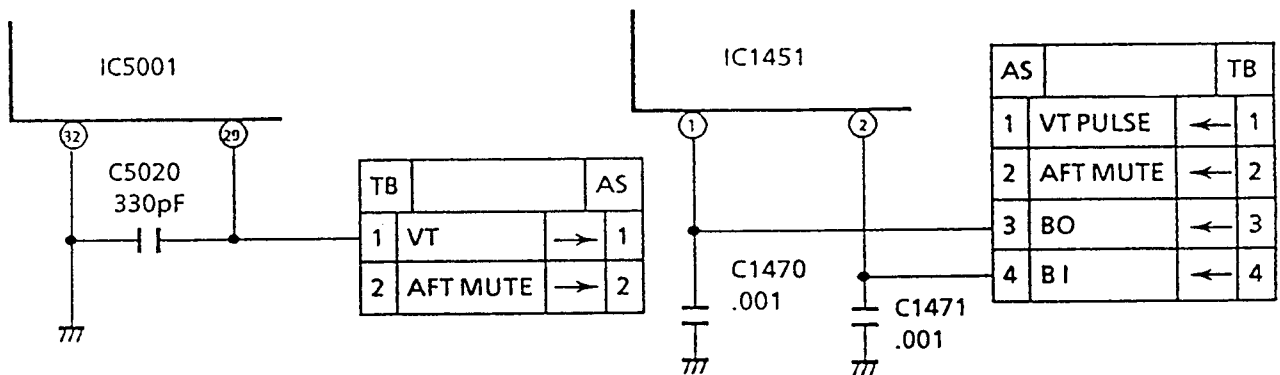

A

B

A

A+B

Model No.	Serial No.
VR6448/75	1127876~
VR6448/75D	0104291~
VR6448/75L	0106436~
VR6448/95P	0115016~
VR6548/75L	1102147~
VR6548/75H	0102148~
VR6548/93L	0100716~

Model No.	Serial No.
VR6448/67	2222049~
VR6448/67L	0104791~
VR6448/73	1107869~
VR6448/69	1131045~
VR6448/79L	0106436~
VR6548/67L	1102746~
VR6548/79L	0105006~
VR6548/00L	0116875~

Service Information

1990-03-05

VIDEO CASSETTE RECORDER VR6448 VR6349
VR6548 VR6449
VR6648 VR6549

VR.O.S.-90-04

To improve the performance in the above mentioned sets, the video search lever item 38 has been changed from 4822 403 53514 into 48 22 403 70007