



ELM304

NTSC Video Generator

Description

The ELM304 is a low-cost NTSC video signal generator in an 8 pin package. Requiring only an external crystal and a few passive components, this circuit produces a stable raster that is suitable for a variety of video applications.

The ELM304 can be 'programmed' to generate either a solid white raster or a four-level gray scale pattern simply by changing the logic level at the mode input pin. A supplied internal pullup resistor further simplifies the circuitry when interfacing to mechanical switches.

Although originally designed to provide a stable video input signal for use while recording audio on video cassette recorders, this circuit can also be used for many other instructional and test purposes. The low power consumption and small size of the circuit also makes it ideal for battery-powered applications.

Applications

- Video Source for Video Cassette Recorders
- Classroom Instructional Aid
- Test Bench Video Generator

Features

- Low power CMOS design - typically 1mA at 5V
- Wide supply range - 3.0 to 5.5 volt operation
- Uses a standard 3.58MHz crystal
- Generates both solid and bar type patterns
- No external amplifier required
- Standard 1V p-p NTSC sync negative output
- Requires no adjustments

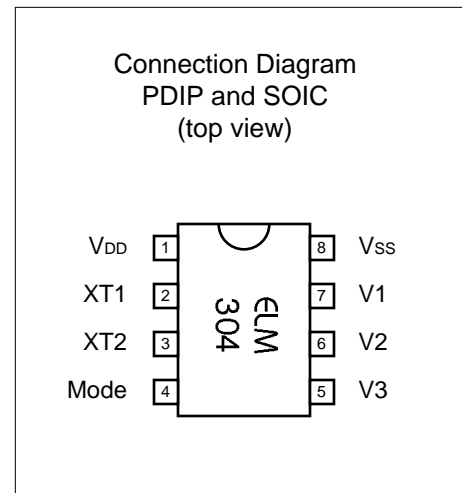

Block Diagram

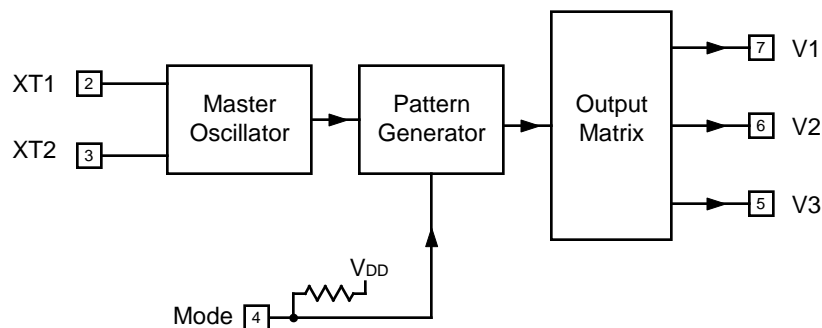



Pin Descriptions

VDD (pin 1)

This pin is the positive supply pin, and should always be the most positive point in the circuit. Internal circuitry connected to this pin is used to provide power on reset of the microprocessor, so an external reset signal is not required. Refer to the Electrical Characteristics section for further information.

XT1 (pin 2) and XT2 (pin 3)

A 3.579545MHz NTSC television colourburst crystal is connected between these two pins. Crystal loading capacitors (typically 27pF) will also normally be connected between each of the pins and Vss.

Mode (pin 4)

The ELM304 can be selected to operate in one of two modes depending on the logic level on this pin. When at a high level (or open-circuited), the generated raster is solid white in colour. If this pin is held at a low level, the circuit will generate a four-level pattern of typically 100%, 60%, 40% and 20% white.

V3, V2, and V1 (pins 5, 6, and 7)

These are the digital to analog converter's logic level output signals. When combined through a few appropriate resistors (see the example application section), a standard 1Vp-p NTSC video signal is created. Output levels during the signal phases are as follows:

Signal Phase	V3	V2	V1
Sync	L	L	L
Blanking	L	L	H
20% White	H	L	L
40% White	L	H	H
60% White	H	L	H
100% White	H	H	H

Vss (pin 8)

Circuit common is connected to this pin. This is the most negative point in the circuit.

Ordering Information

These integrated circuits are available in either the 300 mil plastic DIP format, or in the 200 mil SOIC surface mount type of package. To order, add the appropriate suffix to the part number:

300 mil Plastic DIP..... ELM304P

200 mil SOIC..... ELM304SM

All rights reserved. Copyright ©1999 Elm Electronics.

Every effort is made to verify the accuracy of information provided in this document, but no representation or warranty can be given and no liability assumed by Elm Electronics with respect to the accuracy and/or use of any products or information described in this document. Elm Electronics will not be responsible for any patent infringements arising from the use of these products or information, and does not authorize or warrant the use of any Elm Electronics product in life support devices and/or systems. Elm Electronics reserves the right to make changes to the device(s) described in this document in order to improve reliability, function, or design.



Absolute Maximum Ratings

Storage Temperature..... -65°C to +150°C
 Ambient Temperature with
 Power Applied..... -40°C to +85°C
 Voltage on V_{DD} with respect to V_{SS}..... 0 to +7.5V
 Voltage on any other pin with
 respect to V_{SS}..... -0.6V to (V_{DD} + 0.6V)

Note:

Stresses beyond those listed here will likely damage the device. These values are given as a design guideline only. The ability to operate to these levels is neither inferred nor recommended.

Electrical Characteristics

All values are for operation at 25°C and a 5V supply, unless otherwise noted. For further information, refer to note 1 below.

Characteristic	Minimum	Typical	Maximum	Units	Conditions
Supply Voltage, V _{DD}	3.0	5.0	5.5	V	
V _{DD} rate of rise	0.05			V/ms	see note 2
Average Supply Current, I _{DD}		1.0	2.4	mA	see note 3
Input low voltage	V _{SS}		0.15 V _{DD}	V	
Input high voltage	0.85 V _{DD}		V _{DD}	V	
Internal pullup resistance (pin 4)	300	500	600	K	see note 4
Output low voltage			0.6	V	Current (sink) = 8.7mA
Output high voltage	V _{DD} - 0.7			V	Current (source) = 5.4mA
Timing accuracy		0.25		%	see note 5

Notes:

1. This integrated circuit is produced with a Microchip Technology Inc.'s PIC12C5XX as the core embedded microcontroller. For further device specifications, and possibly clarification of those given, please refer to the appropriate Microchip documentation.
2. This spec must be met in order to ensure that a correct power on reset occurs. It is quite easily achieved using most common types of supplies, but may be violated if one uses a slowly varying supply voltage, as may be obtained through direct connection to solar cells, or some charge pump circuits.
3. Device only. Does not include any current supplied to external circuits.
4. The value of the internal pullup resistance is both supply and temperature dependent.
5. This assumes that the recommended 3.58MHz crystal is used.

Example Application

The ELM304 is typically used in a circuit such as the one shown in Figure 1 below. The type of application determines the supply used – if an AC type supply is available, 5V is likely to be the best choice, but battery operation is also a good alternative. Typical current drain for this circuit is only about 10mA at 3V for the bar pattern, and 13mA for the white. At this rate AAA type alkaline batteries are likely to last about 30hrs while AA alkalines should provide closer to 100hrs of service.

Once the power supply voltage is determined, the values of the summing resistors are chosen using Table 1 as a guideline. Depending on the accuracy desired, some trimming of the values may be required, but these values are likely to provide satisfactory levels for most applications.

Finally, the required type of output pattern should be determined. If it is desirable to be able to change patterns 'on the fly', a switch connected as shown is likely required, but if only one pattern is required, the Mode input can be connected directly to V_{DD} (white) or V_{SS} (bars).

When testing, keep in mind that the output voltage varies directly with loading. Resistor values shown assume a load resistance of 75 connected to the output, and if this is not present, levels will be considerably higher than the 1V p-p that is expected.

As always, good wiring practices should be followed when wiring this circuit. In this case ringing on the supply lines, stray capacitance, etc. are likely to result in visible problems however, so take a little extra care.

	3V	5V
R1	330	680
R2	330	680
R3	220	430
R4	470	150

Table 1 Typical Resistor Values

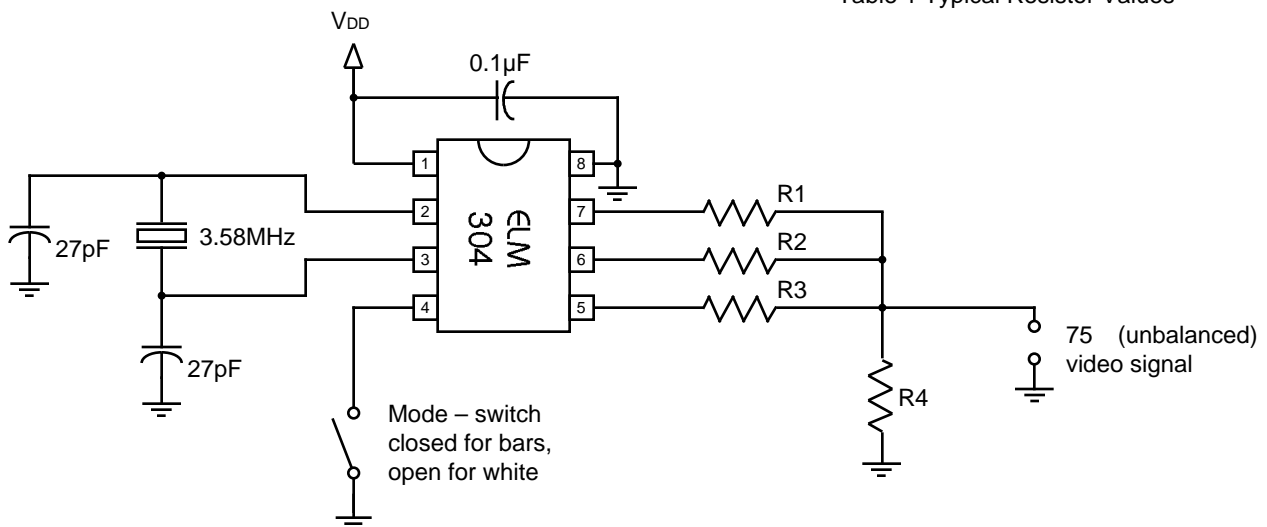

Figure 1. Typical Circuit Configuration