

DATA SHEET

SA578

Unity gain level programmable low power
compandor

Product specification
Replaces data of 1993 December 15
IC17 Data Handbook

1997 Nov 07

Philips Semiconductors



PHILIPS

Unity gain level programmable low power compandor

SA578

DESCRIPTION

The SA578 is a unity gain level programmable compandor designed for low power applications. The SA578 is internally configured as an expander and a compressor to minimize external component count.

The summing amplifiers of the SA578 have 600Ω drive capability and the inverting input of the compressor amplifier is accessible through Pin 9 for summing multiple external signals. Power Down/Mute function is active low and requires an open collector output logic configuration at Pin 8. If Power Down/Mute is not needed, Pin 8 should be left open. When the part is muted, supply current drops to 170mA at 3.6V.

FEATURES

- Operating voltage range: 1.8V to 7V
- Low power consumption (1.4mA @ 3.6V)
- 0dB level programmable (10mV_{RMS} to 1.0V_{RMS})
- Over 90dB of dynamic range
- Wide input/output swing capability
- Low external component count
- SA578 meets cellular radio specifications
- ESD hardened
- Power Down mode (I_{CC} = 170μA @ 3.6V)
- Mute function
- Multiple external summing capability
- 600Ω drive capability

PIN CONFIGURATION

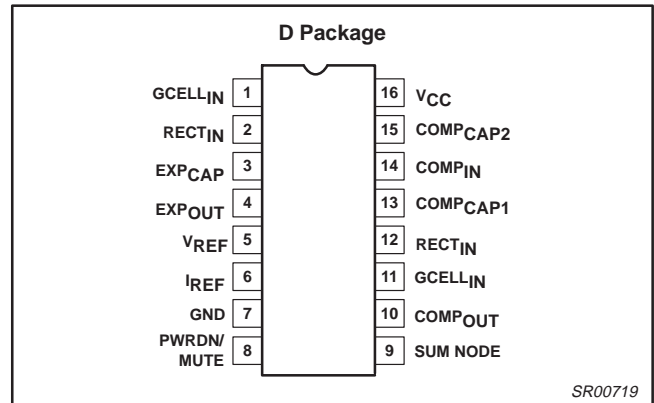

Figure 1. Pin Configuration

APPLICATIONS

- High performance portable communications
- Cellular radio
- Cordless telephone
- Consumer audio
- Wireless microphones
- Modems
- Electric organs
- Hearing aids
- Automatic level control (ALC)

ORDERING INFORMATION

DESCRIPTION	TEMPERATURE RANGE	ORDER CODE	DWG #
16-Pin Plastic Small Outline (SO)	-40 to +85°C	SA578D	SOT109-1

ABSOLUTE MAXIMUM RATINGS

SYMBOL	PARAMETER	RATING	UNITS
		SA578	
V _{CC}	Supply voltage	8	V
T _A	Operating ambient temperature range	-40 to +85	°C
T _{STG}	Storage temperature range	-65 to +150	°C
θ _{JA}	Thermal impedance SO	125	°C/W

Unity gain level programmable low power compandor

SA578

BLOCK DIAGRAM and TEST AND APPLICATION CIRCUIT

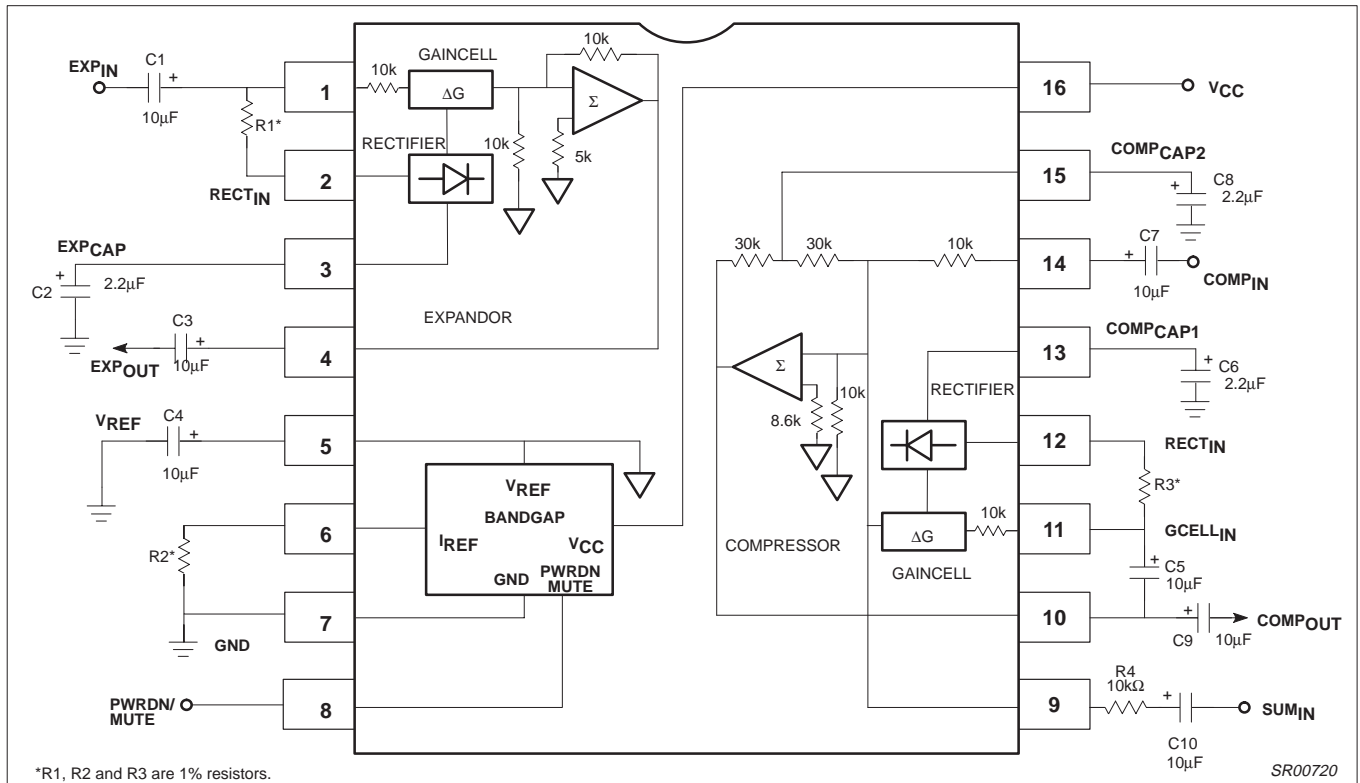

Figure 2. Block Diagram and Test and Application Circuit

Unity gain level programmable low power compandor

SA578

ELECTRICAL CHARACTERISTICS

$T_A = 25^\circ\text{C}$, $V_{CC} = 3.6\text{VDC}$, compandor 0dB level = $-20\text{dBV} = 100\text{mV}_{\text{RMS}}$, output load $R_L = 10\text{k}\Omega$, Freq = 1kHz, unless otherwise specified. R1, R2 and R3 are 1% resistors.

SYMBOL	PARAMETER	TEST CONDITIONS	LIMITS			UNITS
			SA578			
			MIN	TYP	MAX	
V_{CC}	Supply voltage ¹		2	3.6	7	V
I_{CC}	Supply current operating power down	No signal, $R_2 = 100\text{k}\Omega$		1.4 170	2	mA μA
V_{REF}	Reference voltage ²	$V_{CC} = 3.6\text{V}$	1.7	1.8	1.9	V
R_L	Summing amp minimum output load			600		Ω
THD	Total harmonic distortion	1kHz, 0dB, BW = 3.5kHz		0.25	1.0	%
E_{NO}	Expandor output noise voltage	BW = 20kHz, $R_S = 0\Omega$		10	20	μV
0dB	Unity gain level	0dB at 1kHz	-1.0	0.18	1.0	dB
	Programmable range ³	$R_1 = R_3 = 18.7\text{k}\Omega$, $R_2 = 24.3\text{k}\Omega$		0		dBV
		$R_1 = R_3 = 22.6\text{k}\Omega$, $R_2 = 100\text{k}\Omega$		-10		
		$R_1 = R_3 = 7.15\text{k}\Omega$, $R_2 = 100\text{k}\Omega$		-20		
		$R_1 = R_3 = 1.33\text{k}\Omega$, $R_2 = 200\text{k}\Omega$		-40		
V_{OS}	Output voltage offset	No signal	-150	1	150	mV
	Expandor output DC shift	No signal to 0dB	-100	7	100	mV
	Tracking error relative to 0dB output	-20dB expandor	-1.0	0.3	1.0	dB
	Crosstalk, COMP to EXP	1kHz, 0dB, $C_{REF} = 10\mu\text{F}$		-80	-65	dB
V_O	Output swing low			0.2		V
	Output swing high			$V_{CC} - 0.2$		
	Power Down/Mute low level		0		0.4	V
	Power Down/Mute input current	Pin 8 grounded		-65		μA

NOTE:

1. Operation down to $V_{CC} = 1.8\text{V}$ is possible.
2. Reference voltage, V_{REF} , is typically at $1/2 V_{CC}$.
3. Unity gain level can be adjusted CONTINUOUSLY between $-40\text{dBV} = 10\text{mV}_{\text{RMS}}$ and $0\text{dBV} = 1.0\text{V}_{\text{RMS}}$. For details see application note AN1762.

Unity gain level programmable low power compandor

SA578

TYPICAL PERFORMANCE CHARACTERISTICS

$V_{CC} = 3.6V$, $T_A = 25^\circ C$, $R_1=R_3=7.15k\Omega$, $R_2=100k\Omega$, 0dB level = 100mV, Freq. = 1kHz

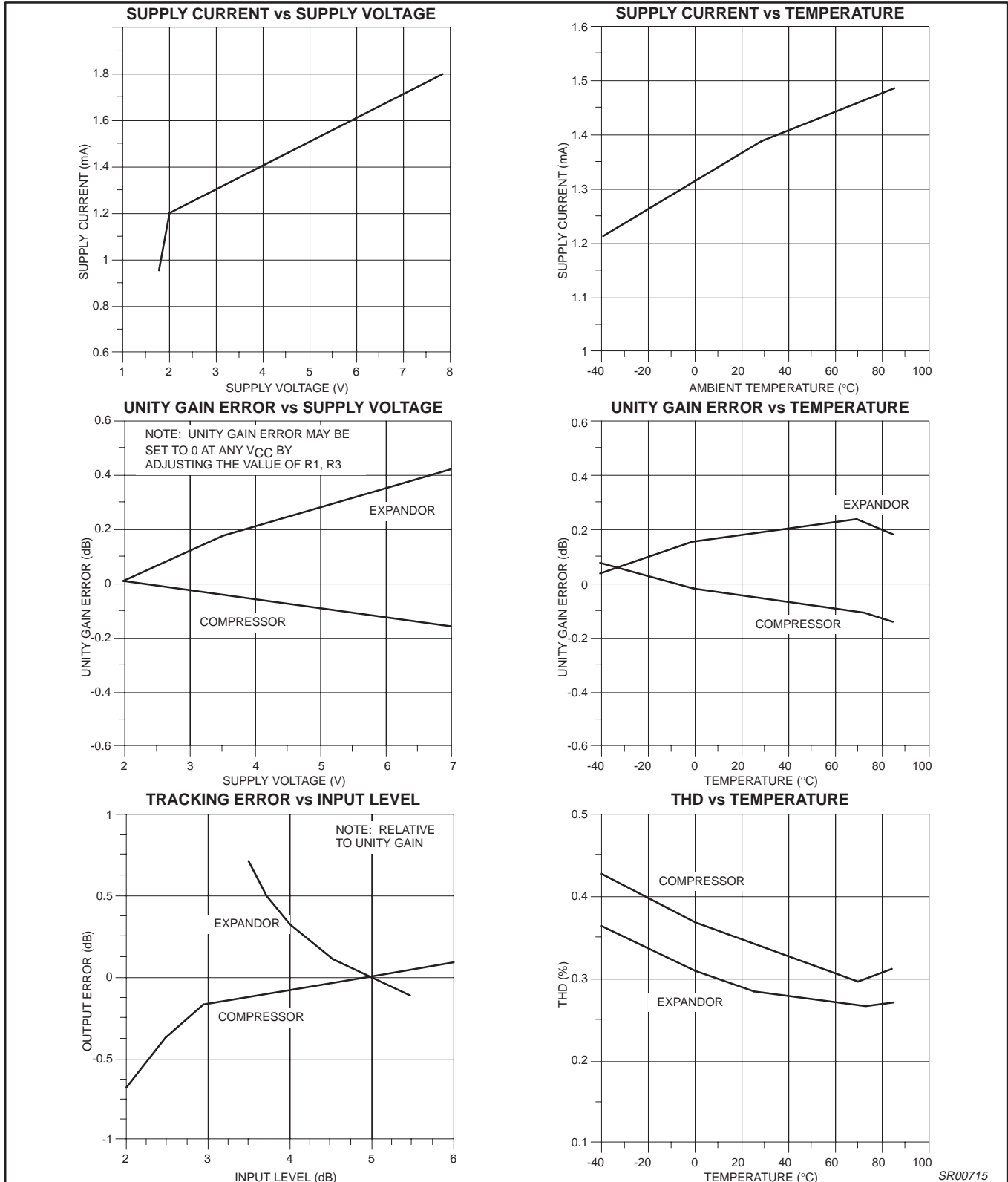

Figure 3. Typical Performance Characteristics

SR00715

Unity gain level programmable low power compandor

SA578

SO16: plastic small outline package; 16 leads; body width 3.9 mm

SOT109-1

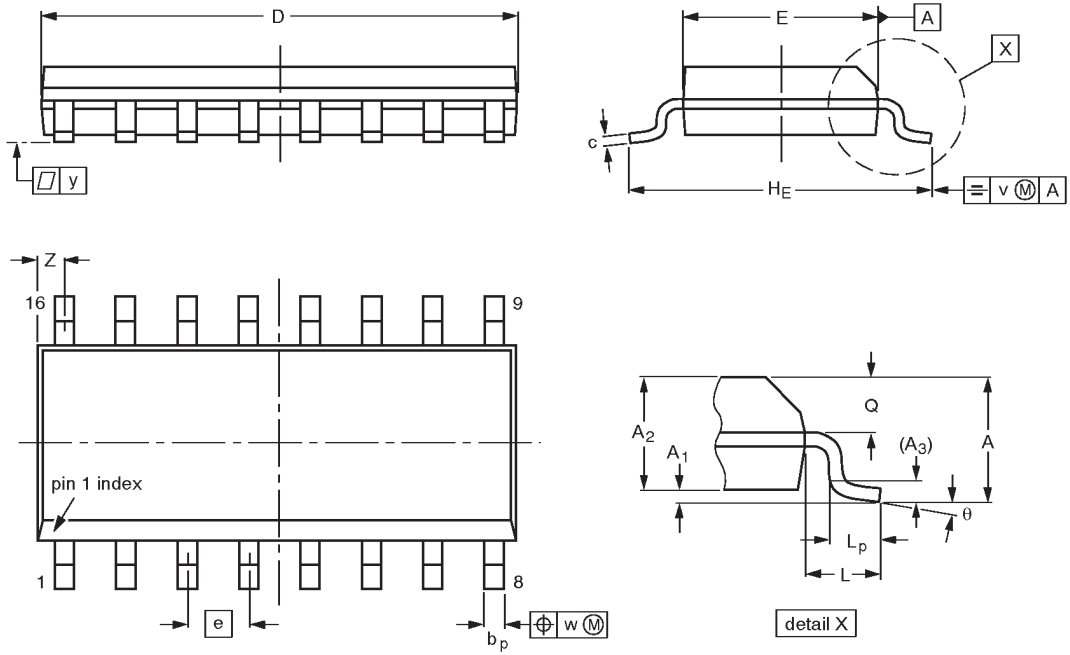

DIMENSIONS (inch dimensions are derived from the original mm dimensions)

UNIT	A max.	A ₁	A ₂	A ₃	b _p	c	D ⁽¹⁾	E ⁽¹⁾	e	H _E	L	L _p	Q	v	w	y	Z ⁽¹⁾	θ
mm	1.75	0.25 0.10	1.45 1.25	0.25	0.49 0.36	0.25 0.19	10.0 9.8	4.0 3.8	1.27	6.2 5.8	1.05	1.0 0.4	0.7 0.6	0.25	0.25	0.1	0.7 0.3	8° 0°
inches	0.069	0.0098 0.0039	0.057 0.049	0.01	0.019 0.014	0.0098 0.0075	0.39 0.38	0.16 0.15	0.050	0.24 0.23	0.041	0.039 0.016	0.028 0.020	0.01	0.01	0.004	0.028 0.012	

Note

1. Plastic or metal protrusions of 0.15 mm maximum per side are not included.

OUTLINE VERSION	REFERENCES				EUROPEAN PROJECTION	ISSUE DATE
	IEC	JEDEC	EIAJ			
SOT109-1	076E07S	MS-012AC				91-08-13 95-01-23

Unity gain level programmable low power compandor

SA578

DEFINITIONS

Data Sheet Identification	Product Status	Definition
<i>Objective Specification</i>	Formative or in Design	This data sheet contains the design target or goal specifications for product development. Specifications may change in any manner without notice.
<i>Preliminary Specification</i>	Preproduction Product	This data sheet contains preliminary data, and supplementary data will be published at a later date. Philips Semiconductors reserves the right to make changes at any time without notice in order to improve design and supply the best possible product.
<i>Product Specification</i>	Full Production	This data sheet contains Final Specifications. Philips Semiconductors reserves the right to make changes at any time without notice, in order to improve design and supply the best possible product.

Philips Semiconductors and Philips Electronics North America Corporation reserve the right to make changes, without notice, in the products, including circuits, standard cells, and/or software, described or contained herein in order to improve design and/or performance. Philips Semiconductors assumes no responsibility or liability for the use of any of these products, conveys no license or title under any patent, copyright, or mask work right to these products, and makes no representations or warranties that these products are free from patent, copyright, or mask work right infringement, unless otherwise specified. Applications that are described herein for any of these products are for illustrative purposes only. Philips Semiconductors makes no representation or warranty that such applications will be suitable for the specified use without further testing or modification.

LIFE SUPPORT APPLICATIONS

Philips Semiconductors and Philips Electronics North America Corporation Products are not designed for use in life support appliances, devices, or systems where malfunction of a Philips Semiconductors and Philips Electronics North America Corporation Product can reasonably be expected to result in a personal injury. Philips Semiconductors and Philips Electronics North America Corporation customers using or selling Philips Semiconductors and Philips Electronics North America Corporation Products for use in such applications do so at their own risk and agree to fully indemnify Philips Semiconductors and Philips Electronics North America Corporation for any damages resulting from such improper use or sale.

Philips Semiconductors
811 East Arques Avenue
P.O. Box 3409
Sunnyvale, California 94088-3409
Telephone 800-234-7381

© Copyright Philips Electronics North America Corporation 1997
 All rights reserved. Printed in U.S.A.

Let's make things better.