



===== Contents =====

1. INTRODUCTION	3
2. FEATURES	3
3. PIN ASSIGNMENTS	3
4. Memory mapping for AD Bus Interface.....	4
5. ABSOLUTE MAXIMUM RATINGS.....	5
6. ELECTRICAL CHARACTERISTICS	5
7. Application circuit.....	6
7.1 AD Bus Interface (with SNC710)	6
7.2 Standard ROM interface (with SNL310)	7
8. BONDING PAD	8



AMENDENT HISTORY

Version	Date	Description
Ver 1.0	March 11, 2003	V1.0 first issue
Ver 1.1	April 18, 2003	Modify the pin assignment table Add bonding pad information & application circuit
Ver 1.2	April 21, 2003	Modify application circuit & bonding pad information
Ver 1.3	August 29, 2003	Modify operation current from typ.4mA -> MAX. 4mA Modify access time Max = 200ns in Electrical Characteristic

1. INTRODUCTION

The SNR008 is a signal power, 8M-bit, read only memory. It is organized as 1M bytes, operates for single 3V power supply, support static standby mode. The SNR008 embedded two different interfaces, one is a standard 8-bit interface bus which compatible with SNL310, another one is a special 8-bit AD (address/data) bus which compatible with SNC710.

SNR008 offers automatic power-down, with power-down controlled by the chip enable "CE". When chip enable goes to high, SNR008 will entry power-down mode in order to save the power consumption.

2. FEATURES

- ◆ Power supply: 2.4V ~ 3.6V
- ◆ Memory Size: 8M-bit
- ◆ Totally static operation
- ◆ Embedded a standard 8-bit bus interface compatible with SNL310 or a 8-bit AD (address/data) bus interface compatible with SNC710
- ◆ Access time: 200ns @3V

3. PIN ASSIGNMENTS

Symbol	I/O	Standard ROM interface	AD Bus interface
TYPE	I	1: Standard ROM type	0: AD Bus interface
A[8..19]	I	Standard ROM Address [8..19]	NC
A[7]	I	Standard ROM Address A7	TESTM
A[6]	I	Standard ROM Address A6	Bank Select 4
A[5]	I	Standard ROM Address A5	Bank Select 3
A[4]	I	Standard ROM Address A4	Bank Select 2
A[3]	I	Standard ROM Address A3	Bank Select 1
A[2]	I	Standard ROM Address A2	Bank Select 0
A[1]	I	Standard ROM Address A1	ALECLK
A[0]	I	Standard ROM Address A0	READY
D[0..7]	I/O	Standard ROM Data [0..7]	Address/Data bus [0..7]
CEB	I	Standard ROM Chip Enable	Chip Enable
OEB	I	Standard ROM Output Enable	NC
VDD	P	3.3volt Positive Power supply	3.3volt Positive Power supply
GND	P	Ground	Ground

4. Memory mapping for AD Bus Interface

For 8-bit AD (address/data) bus interface, all the address and data communication between SNC710 and SNR008 are through data bus D[0..7]. SNC710 allows user to connect maximum 2 external mask ROM, and SNR008 has 5 bank select pins (BS0~BS4) to specify the memory region of each mask ROM.

BS4~BS0	Address Region	BS4~BS0	Address Region
00100	0x0200000 ~ 0x027FFFFF	10010	0x0900000 ~ 0x097FFFFF
00101	0x0280000 ~ 0x02FFFFFFF	10011	0x0980000 ~ 0x09FFFFFFF
00110	0x0300000 ~ 0x037FFFFF	10100	0x0A00000 ~ 0x0A7FFFFF
00111	0x0380000 ~ 0x03FFFFFFF	10101	0x0A80000 ~ 0x0AFFFFFFF
01000	0x0400000 ~ 0x047FFFFF	10110	0x0B00000 ~ 0x0B7FFFFF
01001	0x0480000 ~ 0x04FFFFFFF	10111	0x0B80000 ~ 0x0BFFFFFFF
01010	0x0500000 ~ 0x057FFFFF	11000	0x0C00000 ~ 0x0C7FFFFF
01011	0x0580000 ~ 0x05FFFFFFF	11001	0x0C80000 ~ 0x0CFFFFFFF
01100	0x0600000 ~ 0x067FFFFF	11010	0x0D00000 ~ 0x0D7FFFFF
01101	0x0680000 ~ 0x06FFFFFFF	11011	0x0D80000 ~ 0x0DFFFFFFF
01110	0x0700000 ~ 0x077FFFFF	11100	0x0E00000 ~ 0x0E7FFFFF
01111	0x0780000 ~ 0x07FFFFFFF	11101	0x0E80000 ~ 0x0EFFFFFFF
10000	0x0800000 ~ 0x087FFFFF	11110	0x0F00000 ~ 0x0F7FFFFF
10001	0x0880000 ~ 0x08FFFFFFF	11111	0x0F80000 ~ 0x0FFFFFFF

Table-1

Note: For the address region 0x00000~0x01FFFFFF are reserved, and the setting of bank select pins BS4~BS0 CAN'T be the range 0000~0x0011.

5. ABSOLUTE MAXIMUM RATINGS

Items	Symbol	Min	Max	Unit.
Supply Voltage	V_{DD-V}	-0.3	6.0	V
Input Voltage	V_{IN}	GND-0.3	$V_{DD}+0.3$	V
Operating Temperature	T_{OP}	0	55	°C
Storage Temperature	T_{STG}	-55.0	125.0	°C

6. ELECTRICAL CHARACTERISTICS

Item	Sym.	Min.	Typ.	Max.	Unit	Condition
Operating Voltage	V_{DD}	2.4	-	3.6	V	
Standby current	I_{SBY}	-	1.5	2.0	uA	$V_{DD}=3V$, no load
Operating Current	I_{OPR}	-	4	-	mA	$V_{DD}=3V$, no load
Address access time	tAA	-	-	200	ns	Vdd=3V

7. Application circuit

7.1 AD Bus Interface (with SNC710)

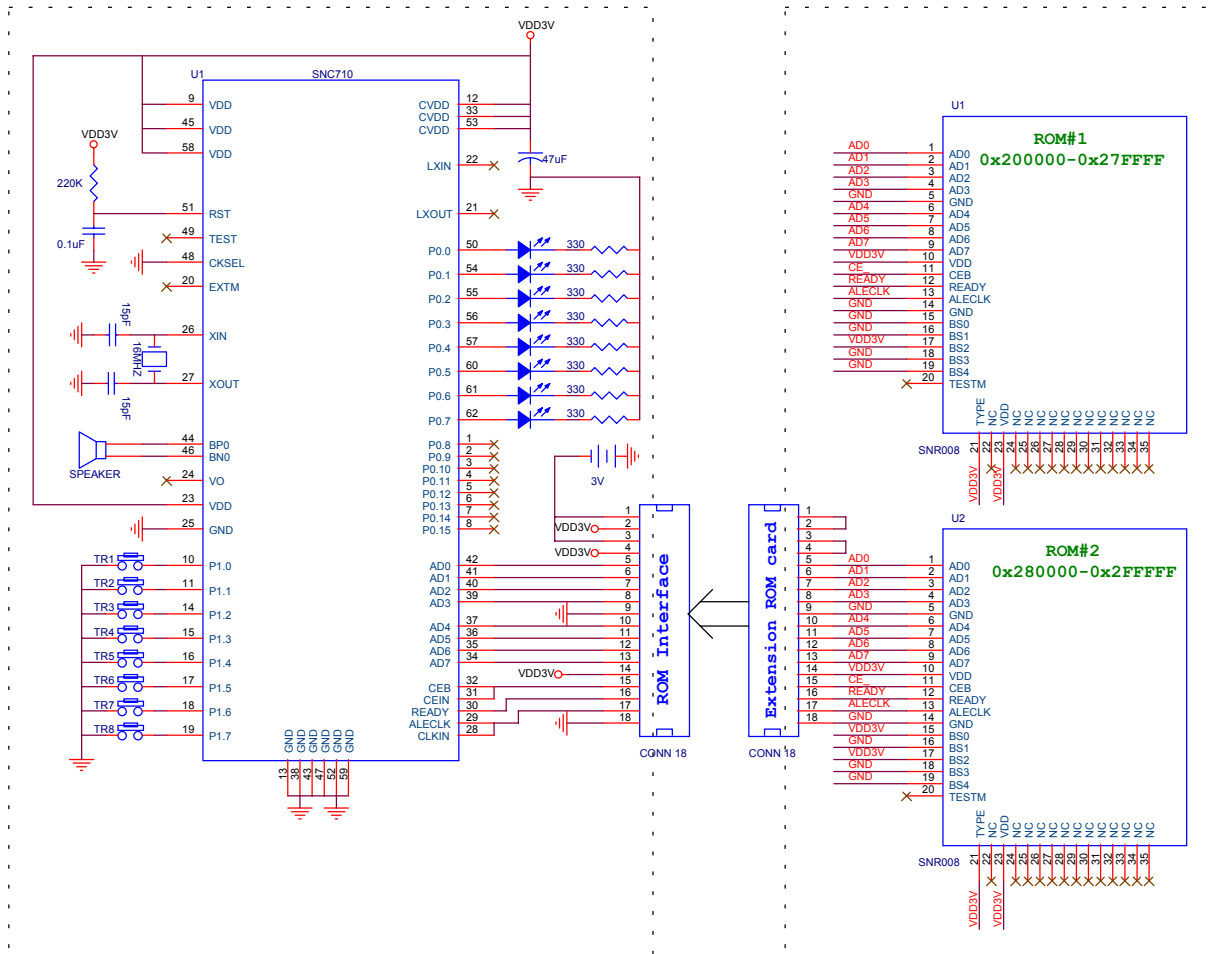

DISCLAIMER

The information appearing in SONiX web pages (“this publication”) is believed to be accurate.

However, this publication could contain technical inaccuracies or typographical errors. The reader should not assume that this publication is error-free or that it will be suitable for any particular purpose. SONiX makes no warranty, express, statutory implied or by description in this publication or other documents which are referenced by or linked to this publication. In no event shall SONiX be liable for any special, incidental, indirect or consequential damages of any kind, or any damages whatsoever, including, without limitation, those resulting from loss of use, data or profits, whether or not advised of the possibility of damage, and on any theory of liability, arising out of or in connection with the use or performance of this publication or other documents which are referenced by or linked to this publication.

This publication was developed for products offered in Taiwan. SONiX may not offer the products discussed in this document in other countries. Information is subject to change without notice. Please contact SONiX or its local representative for information on offerings available. Integrated circuits sold by SONiX are covered by the warranty and patent indemnification provisions stipulated in the terms of sale only. The application circuits illustrated in this document are for reference purposes only. SONIX DISCLAIMS ALL WARRANTIES, INCLUDING THE WARRANTY OF MERCHANTABILITY OR FITNESS FOR ANY PURPOSE. SONIX reserves the right to halt production or alter the specifications and prices, and discontinue marketing the Products listed at any time without notice. Accordingly, the reader is cautioned to verify that the data sheets and other information in this publication are current before placing orders.

Products described herein are intended for use in normal commercial applications. Applications involving unusual environmental or reliability requirements, e.g. military equipment or medical life support equipment, are specifically not recommended without additional processing by SONIX for such application.