

TGA8810-SCC

Gain Block Amplifier

8810

- **2 to 10-GHz Frequency Range**
- **Operates from Single 5-V Supply**
- **Unconditionally Stable**
- **17-dB Typical Gain**
- **Typical ± 0.6 -dB Gain Flatness**
- **1,8796 x 1,6510 x 0,1524 mm (0.074 x 0.065 x 0.006 in.)**

PHOTO ENLARGEMENT

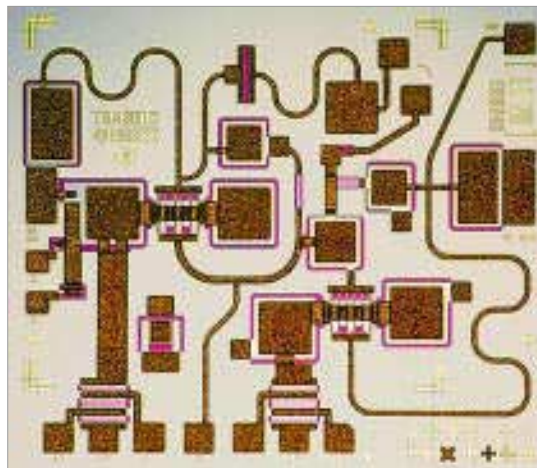

DESCRIPTION

The TriQuint TGA8810 -SCC is a self-biased general purpose amplifier. Two gain stages employ shunt feedback to produce flat gain to 10-GHz. Output power at 1- dB gain compression is typically 17-dBm and noise figure is 6-dB. The TGA8810-SCC uses on-chip DC blocks to allow direct cascading. Three different on-chip self-bias resistors provide the flexibility of selecting bias current and RF performance.

The TGA8810-SCC is available in chip form and is readily assembled using automated equipment. Bond pad and backside metallization is gold plated for compatibility with eutectic alloy attachment methods as well as the thermocompression and thermosonic wire-bonding processes.

**TYPICAL
SMALL SIGNAL
POWER GAIN**

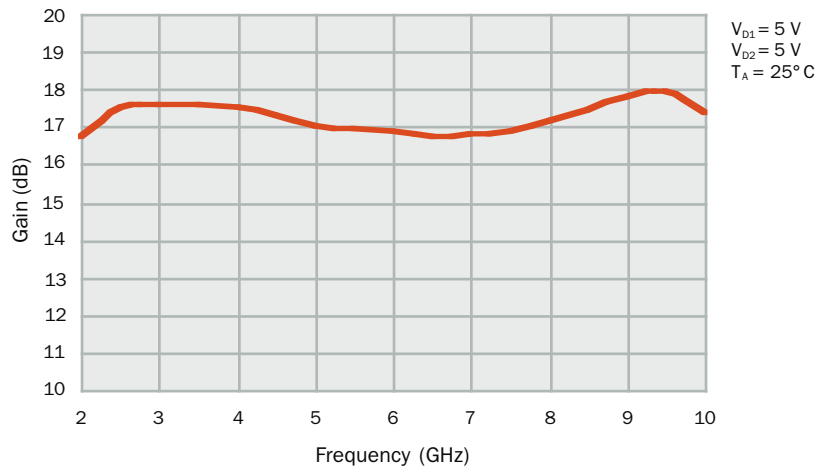

**TYPICAL
NOISE FIGURE**

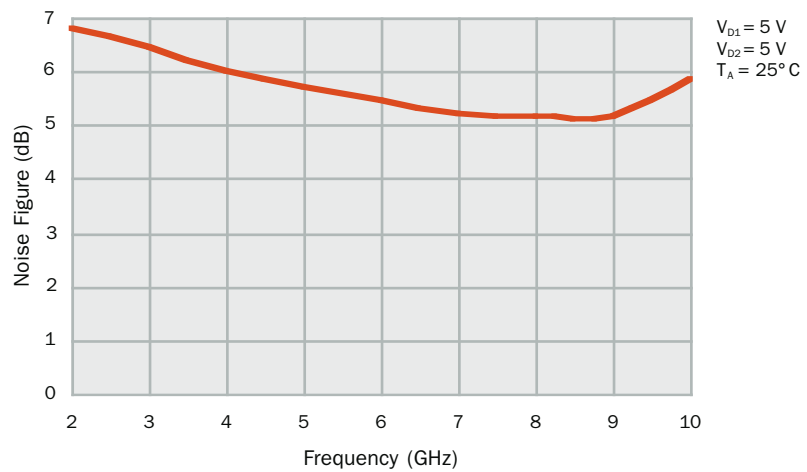

**TYPICAL
OUTPUT POWER
 P_{1dB}**

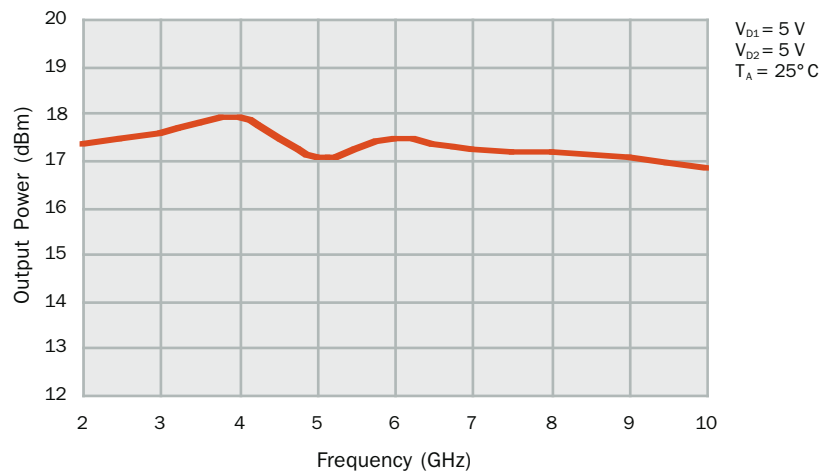

**TYPICAL
RETURN LOSS**

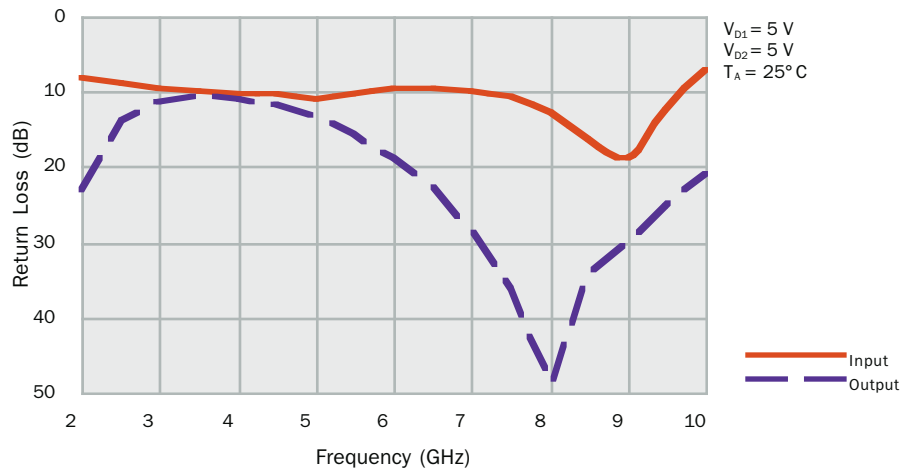

**ABSOLUTE
MAXIMUM RATINGS**

Positive supply voltage, V_{D1}, V_{D2}	8.5 V
Power dissipation at (or below) 25°C base-plate temperature, P_b^*	2.4 W
Operating channel temperature, T_{CH}^{**}	150°C
Mounting temperature (30 sec), T_M	320°C
Storage temperature range, T_{STG}	-65 to 150°C

Ratings over channel temperature range, T_{CH} (unless otherwise noted)

Stresses beyond those listed under “Absolute Maximum Ratings” may cause permanent damage to the device. These are stress ratings only, and functional operation of the device at these or any other conditions beyond those indicated under “RF Characteristics” is not implied. Exposure to absolute maximum rated conditions for extended periods may affect device reliability.

* For operation above 25°C base-plate temperature, derate linearly at the rate of 5 mW/°C.

** Operating channel temperature, T_{CH} , directly affects the device MTF. For maximum life, it is recommended that channel temperature be maintained at the lowest possible level.

TYPICAL S-PARAMETERS

Frequency (GHz)	S ₁₁		S ₂₁		S ₁₂		S ₂₂		GAIN (dB)
	MAG	ANG(°)	MAG	ANG(°)	MAG	ANG(°)	MAG	ANG(°)	
0.5	0.38	-104	0.03	-148	0.001	-13	0.92	-130	-30.8
1.0	0.29	-125	0.99	-177	0.003	180	0.79	165	-0.1
1.5	0.36	-134	4.24	114	0.009	122	0.48	111	12.5
2.0	0.40	-156	6.88	42	0.011	72	0.07	125	16.8
2.5	0.36	-169	7.49	-8	0.009	43	0.21	180	17.5
3.0	0.33	-173	7.58	-45	0.007	27	0.27	164	17.6
3.5	0.31	-175	7.59	-77	0.006	10	0.29	150	17.6
4.0	0.30	-175	7.53	-106	0.004	9	0.28	137	17.5
4.5	0.30	-176	7.36	-133	0.002	5	0.26	126	17.3
5.0	0.29	179	7.10	-157	0.002	2	0.22	115	17.0
5.5	0.31	-178	7.02	179	0.001	-53	0.17	109	16.9
6.0	0.33	179	6.98	156	0.001	-152	0.12	110	16.9
6.5	0.33	173	6.86	134	0.002	-178	0.07	111	16.7
7.0	0.32	166	6.90	113	0.003	169	0.04	120	16.8
7.5	0.29	156	7.01	90	0.004	173	0.02	140	16.9
8.0	0.23	140	7.22	67	0.005	168	0.00	2	17.2
8.5	0.15	110	7.48	43	0.007	177	0.02	0	17.5
9.0	0.11	33	7.75	15	0.009	175	0.03	24	17.8
9.5	0.24	-37	7.87	-15	0.011	170	0.06	52	17.9
10.0	0.44	-75	7.39	-49	0.013	162	0.09	58	17.4
10.5	0.64	-106	6.34	-83	0.016	153	0.11	51	16.0

$$V_{D1} = V_{D2} = 5 \text{ V}, T_A = 25^\circ\text{C}$$

Reference planes for S-parameter data include bondwires as specified in the "Recommended Assembly Diagram".

RF CHARACTERISTICS

	PARAMETER	TEST CONDITIONS	TYP	UNIT	
G _p	Small-signal power gain	f = 2 to 10 GHz	17	dB	
SWR(in)	Input standing wave ratio	f = 2 to 10 GHz	1.9:1	-	
SWR(out)	Output standing wave ratio	f = 2 to 10 GHz	1.2:1	-	
P _{1dB}	Output power at 1-dB gain compression	f = 2 to 10 GHz	17	dBm	
NF	Noise figure	f = 2 to 10 GHz	6	dB	
G _p	Gain flatness	f = 2 to 10 GHz	±0.6	dB	
	Gain temperature coefficient	T _{BP} = -40°C to 90°C	f = 2 GHz f = 6 GHz f = 10 GHz	-0.01 -0.02 -0.02	dB/°C
IP ₃	Output third-order intercept point	f = 2 GHz f = 5 GHz f = 8 GHz	24 26 25	dBm	

$$V_{D1} = V_{D2} = 5 \text{ V}, T_A = 25^\circ\text{C (assembled per Equivalent Schematic unless otherwise noted)}$$

DC CHARACTERISTICS

PARAMETER	TEST CONDITIONS	TYP	UNIT
$I_D = I_{D1} + I_{D2}$ Total positive supply current	$V_{D1} = V_{D2} = 5\text{ V}$	90	mA

T_A = 25°C

EQUIVALENT SCHEMATIC

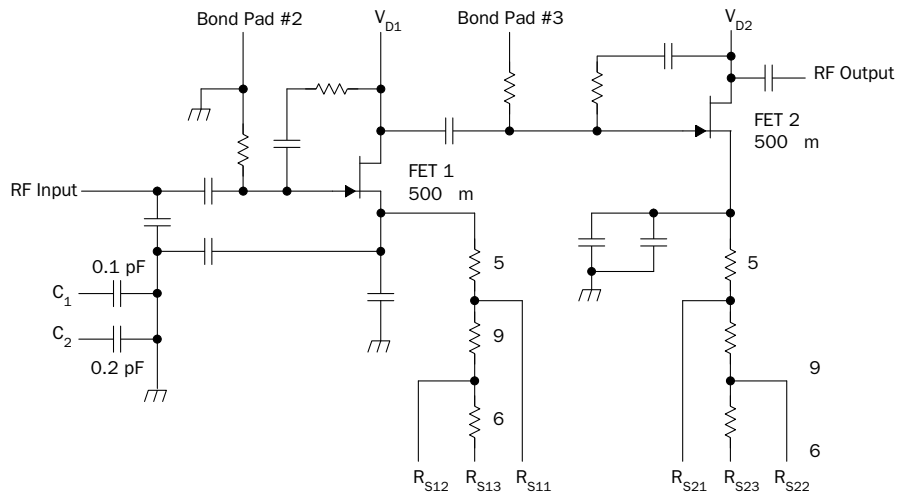

R_{S11} , R_{S12} , R_{S13} , R_{S21} , R_{S22} , and R_{S23} provide the flexibility of selecting bias current and RF performance. C_1 and C_2 can be used in tuning for improved input match. For best results, use the assembly configuration shown in the "Recommended Assembly Diagram" on page 6.

**RECOMMENDED
ASSEMBLY DIAGRAM**

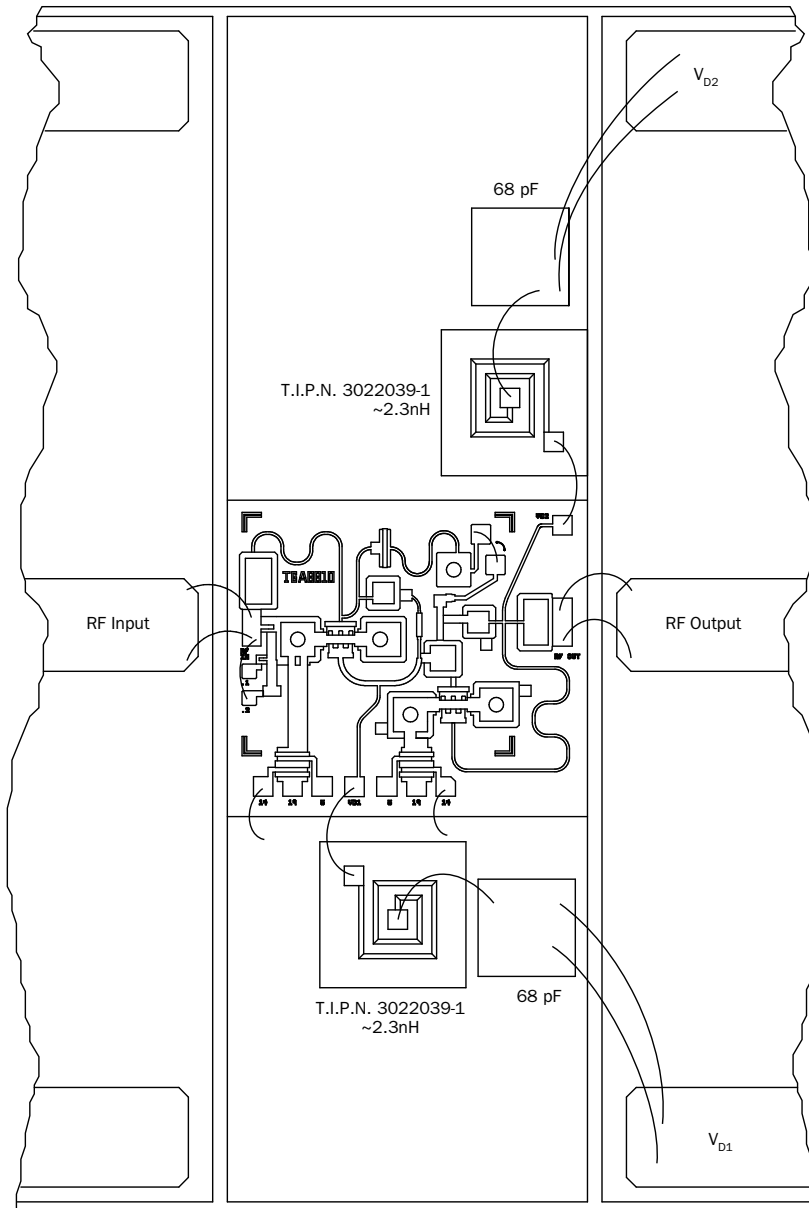

RF connections: bond using two 1-mil diameter, 20 to 25-mil-length gold bond wires at both RF Input and RF Output for optimum RF performance.

Close placement of external components is essential to stability.

Bond using 0.7-mil diameter wires on bond pads 7, 11, 13, and 14 since they are less than the .004 x .004 needed for 1-mil diameter wire.

Two on-chip to on-chip wire bonds are needed for bond pads 1, 2, 3, and 13.

MECHANICAL DRAWING

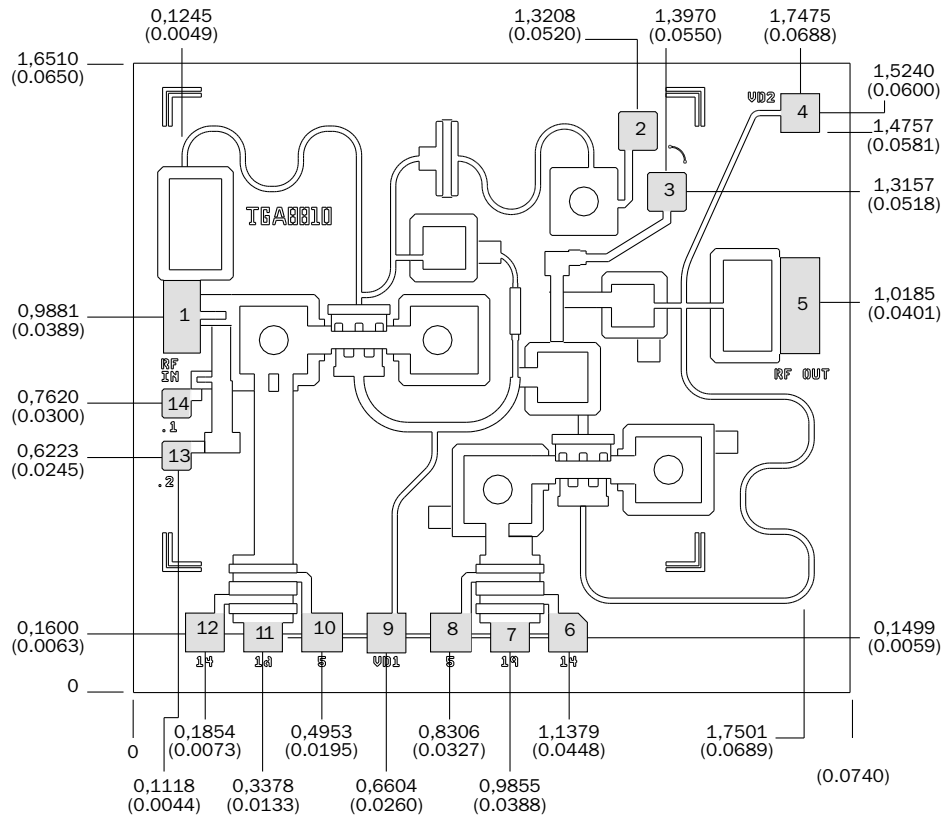

Units: millimeters (inches)

Thickness: 0,1524 (0,006) (reference only)

Chip-edge-to-bond-pad dimensions are shown to center of bond pad.

Chip size tolerance: ± 0,0508 (0,002)

Bond pad #1 (RF Input):	0,1016 x 0,1778 (0,0040 x 0,0070)
Bond pad #2 :	0,1016 x 0,1016 (0,0040 x 0,0040)
Bond pad #3 :	0,1016 x 0,1016 (0,0040 x 0,0040)
Bond pad #4 (V _{D2}):	0,1016 x 0,1016 (0,0040 x 0,0040)
Bond pad #5 (RF Output):	0,0940 x 0,2540 (0,0037 x 0,0100)
Bond pad #6 (R _{S22}):	0,1016 x 0,1016 (0,0040 x 0,0040)
Bond pad #7 (R _{S23}):	0,1016 x 0,0787 (0,0040 x 0,0031)
Bond pad #8 (R _{S21}):	0,1067 x 0,1016 (0,0042 x 0,0040)
Bond pad #9 (V _{D1}):	0,1016 x 0,1041 (0,0040 x 0,0041)
Bond pad #10 (R _{S11}):	0,1067 x 0,1016 (0,0042 x 0,0040)
Bond pad #11 (R _{S13}):	0,1016 x 0,0787 (0,0040 x 0,0031)
Bond pad #12 (R _{S12}):	0,1016 x 0,1016 (0,0040 x 0,0040)
Bond pad #13 (C2):	0,0762 x 0,0762 (0,0030 x 0,0030)
Bond pad #14 (C1):	0,0762 x 0,0762 (0,0030 x 0,0030)