

LOW DROP FIXED AND
ADJUSTABLE POSITIVE VOLTAGE
REGULATORS

DESCRIPTION

The UTC UR233 is a LOW DROP Voltage Regulator able to provide up to 0.8A of Output Current, available even in adjustable version (Vref=1.25V). Concerning fixed versions, are offered the following Output Voltages: 1.8V, 2.5V, 2.85V, 3.0V, 3.3V and 5.0V. The device is supplied in: SOT-223, SOT-89, TO-252, TO-263, TO-263-3, SOP-8 and TO-220. The SOT-223, SOT-89, SOP-8, TO-263, TO-263-3 and TO-252 surface mount packages optimize the thermal characteristics even offering a relevant space saving effect. High efficiency is assured by NPN pass transistor. In fact in the case, unlike than PNP one, the Quiescent Current flows mostly into the load. Only a very common 10µF minimum capacitor is needed for stability. On chip trimming allows the regulator to reach a very tight output voltage tolerance, within ±1% at 25°C. The ADJUSTABLE UR233 is pin to pin compatible with the other standard Adjustable voltage regulators maintaining the better performances in terms of Drop and Tolerance.

FEATURES

- *Low dropout voltage (1V Typ.)
- *Output current up to 0.8A
- *Fixed output voltage of: 1.8V, 2.5V, 2.85V, 3.0V, 3.3V, 5.0V
- *Adjustable version availability (Vref=1.25V)
- *Internal current and thermal limit
- *Available in ±1%(at 25°C) and 2% in all temperature range
- *Supply voltage rejection: 75dB (TYP)
- *Temperature range: 0°C to 125°C

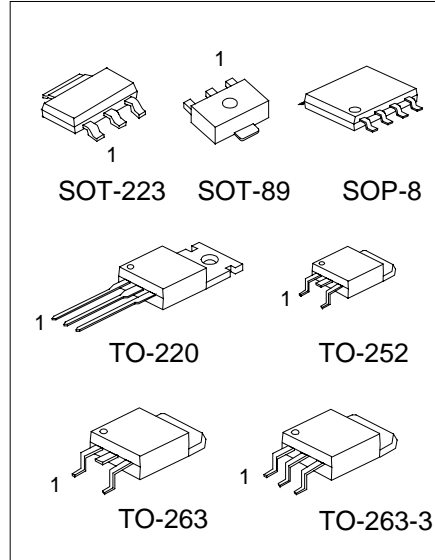

SOP-8 1: GND; 2,3,6,7: Vout;
 4: Vin; 5,8: NC

*Pb-free plating product number: UR233L

UTC UR233 LINEAR INTEGRATED CIRCUIT

MARKING INFORMATION

PACKAGE	VOLTAGE CODE	PIN CODE	PIN 1	PIN 2	PIN 3	MARKING
SOT-223	18:1.8V	A	GND	OUT	IN	
	25:2.5V	B	OUT	GND	IN	
	28:2.85V	C	GND	IN	OUT	
	30:3.0V	D	IN	GND	OUT	
	33:3.3V					
50:5.0V						
SOT-89	AD:ADJ	A	GND	OUT	IN	
		B	OUT	GND	IN	
		C	GND	IN	OUT	
		D	IN	GND	OUT	
TO-220 TO-252 TO-263 TO-263-3		A	GND	OUT	IN	
		B	OUT	GND	IN	
		C	GND	IN	OUT	
		D	IN	GND	OUT	

BLOCK DIAGRAM

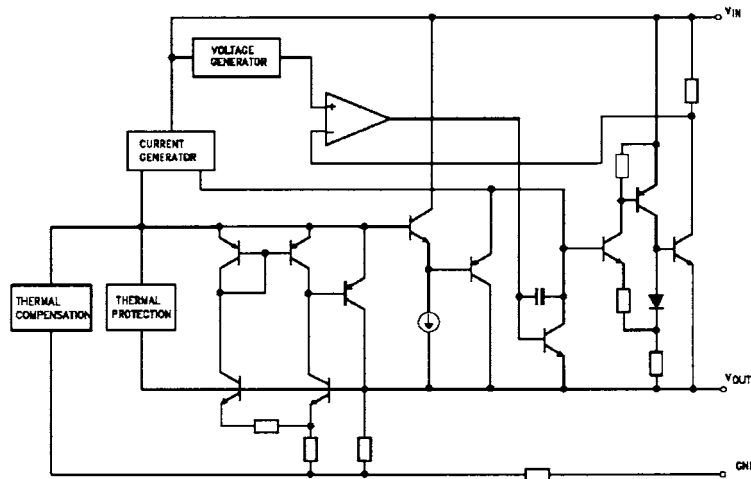

UTC UR233 LINEAR INTEGRATED CIRCUIT

ABSOLUTE MAXIMUM RATINGS

PARAMETER	SYMBOL	VALUE	UNIT
DC Input Voltage	V _{IN}	12	V
Power Dissipation	P _{tot}	12	W
Storage temperature	T _{stg}	-65 ~ +150	°C
Operating Junction Temperature	Top	0 ~ +125	°C

Note: Absolute Maximum Ratings are those value beyond which damage to the device may occur. Functional operation under there condition is not implied. Over the above suggested Max Power Dissipation a Short Circuit could definitively damage the device.

THERMAL DATA

PARAMETER	SYMBOL	VALUE	UNIT
Thermal Resistance Junction-case	R _{th-case}		
SOT-223		15	°C/W
SOP-8		20	°C/W
TO-252		8	°C/W
TO-220		3	°C/W
TO-263		3	°C/W
Thermal Resistance Junction-ambient	R _{thj-amb}		
TO-220		50	°C/W

UTC UR233-1.8 ELECTRICAL CHARACTERISTICS

(refer to the test circuits, T_j=0 to 125°C, Co=10μF unless otherwise specified)

PARAMETER	SYMBOL	TEST CONDITIONS	MIN.	TYP.	MAX.	UNIT
Output Voltage	V _o	V _{in} =3.8V, I _o =10mA, T _j =25°C	1.782	1.800	1.818	V
Output Voltage	V _o	I _o =2 to 800mA, V _{in} =3.2 to 10V	1.764		1.836	V
Line Regulation	ΔV _o	V _{in} =3.2 to 10V, I _o =2mA		1	6	mV
Load Regulation	ΔV _o	V _{in} =3.2V, I _o =2 to 800/mA		1	10	mV
Temperature stability	ΔV _o			0.5		%
Long Term Stability	ΔV _o	1000 hrs, T _j =125°C		0.3		%
Operating Input Voltage	V _{in}	I _o =100mA			12	V
Quiescent Current	I _d	V _{in} ≤10V		5	10	mA
Output Current	I _o	V _{in} =6.8V, T _j =25°C	800	950	1200	mA
Output Noise Voltage	e _N	B=10Hz to 10KHz, T _j =25°C		100		μV
Supply Voltage Rejection	SVR	I _o =40mA, f=120Hz, T _j =25°C, V _{in} =4.8V, V _{ripple} =1V _{pp}	60	75		dB
Dropout Voltage	V _d				1.50	V
Thermal Regulation		T _a =25°C, 30ms Pulse		0.01	0.10	%/W

UTC UR233 ELECTRICAL CHARACTERISTICS

(refer to the test circuits, T_j=0 to 125°C, Co=10μF unless otherwise specified)

PARAMETER	SYMBOL	TEST CONDITIONS	MIN.	TYP.	MAX.	UNIT
Output Voltage	V _o	V _{in} =4.5V, I _o =10mA, T _j =25°C	±1% 2.475	2.500	2.525	V
Output Voltage	V _o	I _o =2 to 800mA, V _{in} =3.9 to 10V	±2% 2.450	2.500	2.550	V
Output Voltage	V _o	I _o =2 to 800mA, V _{in} =3.9 to 10V	±4% 2.400		2.600	V
Line Regulation	ΔV _o	V _{in} =3.9 to 10V, I _o =2mA		1	6	mV
Load Regulation	ΔV _o	V _{in} =3.9V, I _o =2 to 800mA		1	10	mV
Temperature stability	ΔV _o			0.5		%

UTC UNISONIC TECHNOLOGIES CO., LTD. 3

UTC UR233 LINEAR INTEGRATED CIRCUIT

PARAMETER	SYMBOL	TEST CONDITIONS	MIN.	TYP.	MAX.	UNIT
Long Term Stability	ΔV_o	1000 hrs, $T_j=125^\circ\text{C}$		0.3		%
Operating Input Voltage	V_{in}	$I_o=100\text{mA}$			12	V
Quiescent Current	I_d	$V_{in}\leq 10\text{V}$		5	10	mA
Output Current	I_o	$V_{in}=7.5\text{V}$, $T_j=25^\circ\text{C}$	800	950	1200	mA
Output Noise Voltage	eN	$B=10\text{Hz to }10\text{kHz}$, $T_j=25^\circ\text{C}$		100		μV
Supply Voltage Rejection	SVR	$I_o=40\text{mA}$, $f=120\text{Hz}$, $T_j=25^\circ\text{C}$, $V_{in}=5.5\text{V}$, $V_{ripple}=1\text{Vpp}$	60	75		dB
Dropout Voltage	V_d				1.50	V
Thermal Regulation		$T_a=25^\circ\text{C}$, 30ms Pulse		0.01	0.10	%/W

UTC UR233-2.85 ELECTRICAL CHARACTERISTICS

(refer to the test circuits, $T_j=0$ to 125°C , $C_o=10\mu\text{F}$ unless otherwise specified)

PARAMETER	SYMBOL	TEST CONDITIONS	MIN.	TYP.	MAX.	UNIT
Output Voltage	V_o	$V_{in}=4.85\text{V}$, $I_o=10\text{mA}$, $T_j=25^\circ\text{C}$	2.82	2.85	2.88	V
Output Voltage	V_o	$I_o=2$ to 800mA , $V_{in}=4.25$ to 10V	2.79		2.91	V
Line Regulation	ΔV_o	$V_{in}=4.25$ to 10V , $I_o=2\text{mA}$		1	6	mV
Load Regulation	ΔV_o	$V_{in}=4.25\text{V}$, $I_o=2$ to 800mA		1	10	mV
Temperature stability	ΔV_o			0.5		%
Long Term Stability	ΔV_o	1000 hrs, $T_j=125^\circ\text{C}$		0.3		%
Operating Input Voltage	V_{in}	$I_o=100\text{mA}$			12	V
Quiescent Current	I_d	$V_{in}\leq 10\text{V}$		5	10	mA
Output Current	I_o	$V_{in}=7.85\text{V}$, $T_j=25^\circ\text{C}$	800	950	1200	mA
Output Noise Voltage	eN	$B=10\text{Hz to }10\text{kHz}$, $T_j=25^\circ\text{C}$		100		μV
Supply Voltage Rejection	SVR	$I_o=40\text{mA}$, $f=120\text{Hz}$, $T_j=25^\circ\text{C}$, $V_{in}=5.85\text{V}$, $V_{ripple}=1\text{Vpp}$	60	75		DB
Dropout Voltage	V_d				1.50	V
Thermal Regulation		$T_a=25^\circ\text{C}$, 30ms Pulse		0.01	0.10	%/W

UTC UR233-3.0 ELECTRICAL CHARACTERISTICS

(refer to the test circuits, $T_j=0$ to 125°C , $C_o=10\mu\text{F}$ unless otherwise specified)

PARAMETER	SYMBOL	TEST CONDITIONS	MIN.	TYP.	MAX.	UNIT	
Output Voltage	V_o	$V_{in}=5\text{V}$, $I_o=10\text{mA}$, $T_j=25^\circ\text{C}$	$\pm 1\%$	2.97	3.00	3.03	V
			$\pm 2\%$	2.94	3.00	3.06	V
Output Voltage	V_o	$I_o=2$ to 800mA , $V_{in}=4.5$ to 10V	$\pm 2\%$	2.94		3.06	V
			$\pm 4\%$	2.88		3.12	V
Line Regulation	ΔV_o	$V_{in}=4.5$ to 12V , $I_o=2\text{mA}$		1	6	mV	
Load Regulation	ΔV_o	$V_{in}=4.5\text{V}$, $I_o=2$ to 800mA		1	10	mV	
Temperature stability	ΔV_o			0.5		%	
Long Term Stability	ΔV_o	1000 hrs, $T_j=125^\circ\text{C}$		0.3		%	
Operating Input Voltage	V_{in}	$I_o=100\text{mA}$			12	V	
Quiescent Current	I_d	$V_{in}\leq 12\text{V}$		5	10	mA	
Output Current	I_o	$V_{in}=8\text{V}$, $T_j=25^\circ\text{C}$	800	950	1200	mA	
Output Noise Voltage	eN	$B=10\text{Hz to }10\text{kHz}$, $T_j=25^\circ\text{C}$		100		μV	
Supply Voltage Rejection	SVR	$I_o=40\text{mA}$, $f=120\text{Hz}$, $T_j=25^\circ\text{C}$, $V_{in}=6\text{V}$, $V_{ripple}=1\text{Vpp}$	60	75		dB	
Dropout Voltage	V_d				1.50	V	
Thermal Regulation		$T_a=25^\circ\text{C}$, 30ms Pulse		0.01	0.10	%/W	

UTC UR233 LINEAR INTEGRATED CIRCUIT

UTC UR233-3.3 ELECTRICAL CHARACTERISTICS

(refer to the test circuits, $T_j=0$ to 125°C , $C_o=10\mu\text{F}$ unless otherwise specified)

PARAMETER	SYMBOL	TEST CONDITIONS	MIN.	TYP.	MAX.	UNIT	
Output Voltage	V_o	$V_{in}=5.3\text{V}$, $I_o=10\text{mA}$, $T_j=25^\circ\text{C}$	$\pm 1\%$	3.267	3.300	3.333	V
			$\pm 2\%$	3.235	3.300	3.365	V
Output Voltage	V_o	$I_o=2$ to 800mA , $V_{in}=4.75$ to 10V	$\pm 2\%$	3.235		3.365	V
			$\pm 4\%$	3.160		3.440	V
Line Regulation	ΔV_o	$V_{in}=4.75$ to 12V , $I_o=2\text{mA}$		1	6	mV	
Load Regulation	ΔV_o	$V_{in}=4.75\text{V}$, $I_o=2$ to 800mA		1	10	mV	
Temperature stability	ΔV_o			0.5		%	
Long Term Stability	ΔV_o	1000 hrs, $T_j=125^\circ\text{C}$		0.3		%	
Operating Input Voltage	V_{in}	$I_o=100\text{mA}$			12	V	
Quiescent Current	I_d	$V_{in}\leq 12\text{V}$		5	10	mA	
Output Current	I_o	$V_{in}=8.3\text{V}$, $T_j=25^\circ\text{C}$	800	950	1200	mA	
Output Noise Voltage	eN	$B=10\text{Hz}$ to 10KHz , $T_j=25^\circ\text{C}$		100		μV	
Supply Voltage Rejection	SVR	$I_o=40\text{mA}$, $f=120\text{Hz}$, $T_j=25^\circ\text{C}$, $V_{in}=6.3\text{V}$, Ripple= 1V_{pp}	60	75		DB	
Dropout Voltage	V_d				1.50	V	
Thermal Regulation		$T_a=25^\circ\text{C}$, 30ms Pulse		0.01	0.10	%/W	

UTC UR233-5.0 ELECTRICAL CHARACTERISTICS

(refer to the test circuits, $T_j=0$ to 125°C , $C_o=10\mu\text{F}$ unless otherwise specified)

PARAMETER	SYMBOL	TEST CONDITIONS	MIN.	TYP.	MAX.	UNIT	
Output Voltage	V_o	$V_{in}=7\text{V}$, $I_o=10\text{mA}$, $T_j=25^\circ\text{C}$	$\pm 1\%$	4.95	5.00	5.05	V
			$\pm 2\%$	4.90	5.00	5.10	V
Output Voltage	V_o	$I_o=2$ to 800mA , $V_{in}=6.5$ to 12V	$\pm 2\%$	4.90		5.10	V
			$\pm 4\%$	4.80		5.20	V
Line Regulation	ΔV_o	$V_{in}=6.5$ to 12V , $I_o=2\text{mA}$		1	10	mV	
Load Regulation	ΔV_o	$V_{in}=6.5\text{V}$, $I_o=2$ to 800mA		1	15	mV	
Temperature stability	ΔV_o			0.5		%	
Long Term Stability	ΔV_o	1000 hrs, $T_j=125^\circ\text{C}$		0.3		%	
Operating Input Voltage	V_{in}	$I_o=100\text{mA}$			12	V	
Quiescent Current	I_d	$V_{in}\leq 12\text{V}$		5	10	mA	
Output Current	I_o	$V_{in}=10\text{V}$, $T_j=25^\circ\text{C}$	800	950	1200	mA	
Output Noise Voltage	eN	$B=10\text{Hz}$ to 10KHz , $T_j=25^\circ\text{C}$		100		μV	
Supply Voltage Rejection	SVR	$I_o=40\text{mA}$, $f=120\text{Hz}$, $T_j=25^\circ\text{C}$, $V_{in}=8\text{V}$, Ripple= 1V_{pp}	60	75		dB	
Dropout Voltage	V_d				1.50	V	
Thermal Regulation		$T_a=25^\circ\text{C}$, 30ms Pulse		0.01	0.10	%/W	

UTC UR233 LINEAR INTEGRATED CIRCUIT

UTC UR233-ADJUSTABLE ELECTRICAL CHARACTERISTICS

(refer to the test circuits, $T_j=0$ to 125°C , $C_o=10\mu\text{F}$ unless otherwise specified)

PARAMETER	SYMBOL	TEST CONDITIONS	MIN.	TYP.	MAX.	UNIT
Reference Voltage	V_{ref}	$V_{in-Vo}=2\text{V}$, $I_o=10\text{mA}$, $T_j=25^{\circ}\text{C}$	1.238	1.25	1.262	V
Reference Voltage	V_{ref}	$I_o=10$ to 800mA , $V_{in-Vo}=1.5$ to 10V	1.225		1.275	V
Line Regulation	ΔV_o	$V_{in-Vo}=1.5$ to 13.75V , $I_o=10\text{mA}$		0.035	0.200	%
Load Regulation	ΔV_o	$V_{in-Vo}=3\text{V}$, $I_o=10$ to 800mA		0.10	0.400	%
Temperature stability	ΔV_o			0.50		%
Long Term Stability	ΔV_o	1000 hrs, $T_j=125^{\circ}\text{C}$		0.3		%
Operating Input Voltage	V_{in}				12	V
Adjustment Pin Current	I_{adj}	$V_{in}\leq 12\text{V}$		60	120	μA
Adjustment Pin Current Change	ΔI_{adj}	$V_{in-Vo}=1.5$ to 10V , $I_o=10$ to 800mA		1	5	μA
Minimum Load Current	$I_o(\text{min})$	$V_{in}=12\text{V}$		2	5	mA
Output Current	I_o	$V_{in-Vo}=5\text{V}$, $T_j=25^{\circ}\text{C}$	800	950	1200	mA
Output Noise (% V_o)	eN	$B=10\text{Hz}$ to 10KHz , $T_j=25^{\circ}\text{C}$		0.003		%
Supply Voltage Rejection	SVR	$I_o=40\text{mA}$, $f=120\text{Hz}$, $T_j=25^{\circ}\text{C}$, $V_{in-Vo}=3\text{V}$, $V_{ripple}=1\text{Vpp}$	60	75		dB
Dropout Voltage	V_d				1.50	V
Thermal Regulation		$T_a=25^{\circ}\text{C}$, 30ms Pulse		0.01	0.10	%/W

UTC UR233 LINEAR INTEGRATED CIRCUIT

APPLICATION CIRCUIT

FIXED VOLTAGE

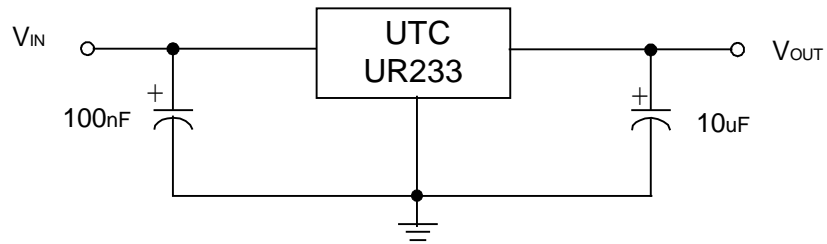

ADJUSTABLE

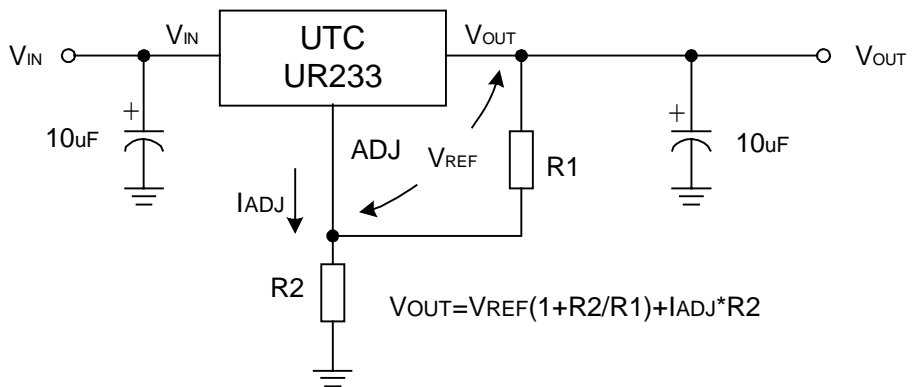

UTC UR233 LINEAR INTEGRATED CIRCUIT

TYPICAL CHARACTERISTICS

Fig.1 Reference Voltage vs. Temperature

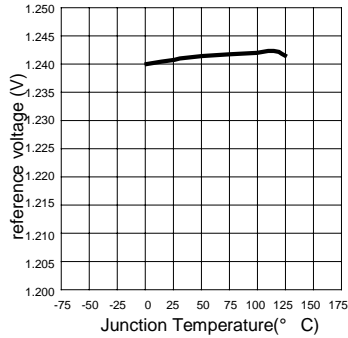

Fig.2 Output Voltage vs. Temperature

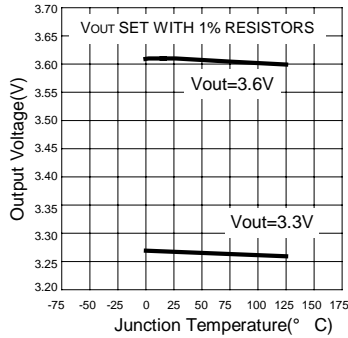
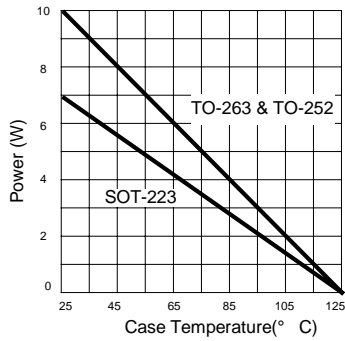

Fig.3 Maximum Power Dissipation



UTC assumes no responsibility for equipment failures that result from using products at values that exceed, even momentarily, rated values (such as maximum ratings, operating condition ranges, or other parameters) listed in products specifications of any and all UTC products described or contained herein. UTC products are not designed for use in life support appliances, devices or systems where malfunction of these products can be reasonably expected to result in personal injury. Reproduction in whole or in part is prohibited without the prior written consent of the copyright owner. The information presented in this document does not form part of any quotation or contract, is believed to be accurate and reliable and may be changed without notice.