



Shenzhen HB Science & Technology Co., Ltd

zhren

# Technical Specification

液晶之友 电话: 020-33819057  
Http://www.lcdfriends.com

**Model:CLAA201VA 02**

**Shenzhen HB Science & Technology Co., Ltd**

BLOCK 1, LONGWU INDUSTRIAL ESTATE  
SHANGTANG VILLEGE, LONGHUA TOWN  
BAOAN DISTRICT, SHENZHEN CITY  
GUANG TONG PROVINCE,P.R.CHINA

TEL: +86-755-28115516 FAX: +86-755-28115795

T- 3650002- 000- A

## 1. OVERVIEW

CLAA201VA02 is 20.1" color TFT-LCD (Thin Film Transistor Liquid Crystal Display) module composed of LCD Panel, Driver ICs, Control Circuit Board, Backlight. By applying 8 bit digital data, 640 ×480, 16.7M-color images are displayed on the 20.1" diagonal screen. Input power voltage is 5.0V for LCD driving and interface of data and control signals is CMOS. General specifications are summarized in the following table:

ITEM	SPECIFICATION
Display Area(mm)	408.0(H) × 306.0(V) (20.1 inch diagonal)
Number of Pixels	640(H) × 480(V)
Pixel Pitch(mm)	0.6375(H) × 0.6375(V)
Color Pixel Arrangement	RGB vertical strip
Display Mode	Normally White, TN
Number of Colors	16.7M (8bits/color)
Brightness(cd/m <sup>2</sup> )	500(cd/m <sup>2</sup> ) @6.0mA
Response Time	16ms
Viewing Angle	(-75~75)(H), (-65~70)(V)(Typ.)
Wide Viewing Angle Technology	Super wide view film
Surface Treatment	Hard coating:3H ; Anti-glare
Electrical Interface	CMOS(VIN=3~5V, 1pixel/clock)
Total Module Power(W)	30W
Module Size(mm)	453.6(W) × 342.9(H) × 22.4(D)
Module Weight(g)	3410 (Typ.)
Backlight Unit	6 CCFLs side-lighting

The LCD Products listed on this document are not suitable for use of aerospace equipment, submarine cables, nuclear reactor control system and life support systems. If customers intend to use these LCD products for above application or not listed in "Standard" as follows, please contact our sales people in advance.

Standard: Computer, Office equipment, Communication equipment, Test and Measurement equipment, Machine tool, Industrial robot, Audio and Visual equipment, Other consumer products.

## 2. ABSOLUTE MAXIMUM RATINGS

ITEM	SYMBOL	MIN.	MAX.	UNIT	REMARK
Power Supply Voltage for LCD	VCC	-0.3	7.0	V	
Logic Input Voltage	VDDD	-0.3	6.0	V	
Voltage of Lamp	VL	-	2000	V <sub>rms</sub>	
Current of Lamp	IL	0	8.0	mA <sub>rms</sub>	
Frequency of Lamp	FL	-	80	kHz	
ESD(Static electricity)	VESDt	-200	200	V	Note1
	VESDc	-8000	8000	V	
ICC Rush Current	IRUSH	-	6	A	Note2
Operation Temperature *1)	Top	0	50		Note3, 4
Storage Temperature *1)	Tstg	-20	60		Note3, 4

[Note1] Test condition : Follow IEC 1000-4-2:

VESDt : for Input connector ; VESDc : for Module

[Note2] 5 μ sec. If rise time of VDDD increases, then I<sub>RUSH</sub> decrease.

[Note3] Be without condensation while humidity 90% RH.

[Note4] Humidity

Relative Humidity 90% (Ta 40 )

Wet Bulb Temperature 39 (Ta 40 )

### 3. ELECTRICAL CHARACTERISTICS

(a)TFT-LCD

ITEM	SYMBOL	MIN	TYP	MAX	UNIT	REMARK
Power Supply Voltage for LCD	VCC	4.5	5.0	5.5	V	Note1
Power Supply Current for LCD	ICC	--	240	450	mA	Note2
Permissive Input Ripple Voltage	VRP	--	--	100	mVp-p	Vcc=12V
Logic Input Voltage	High	VIH	2.5	3.3	V	
	Low	VIL	0	--	0.9	V

[Note 1]

1) VCC-turn-on conditions:

t1 10ms                      400ms    t4  
 200ms < t2                200ms    t5  
 0 < t3 50ms                0    t6

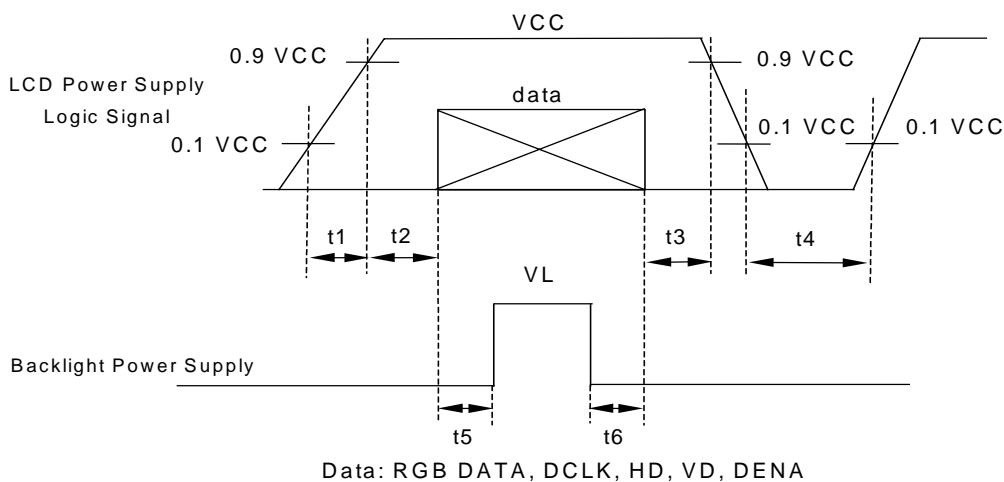

2) VCC-dip conditions

- When 3.6V < VCC < 4.5V, then td = 10 ms
- VCC > 4.5V

VCC-dip conditions should also follow the VCC-turn-on conditions.

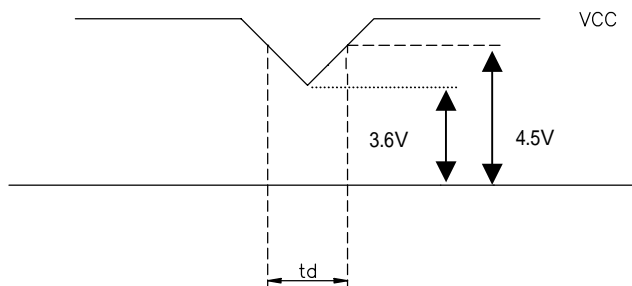

[Note 2] Typical current situation

256-gray-bar pattern, 480 line mode, VCC=5 V, fV=60 Hz, fH=31.5KHz, fCLK=25 MHz

(b) Backlight

ITEM	SYMBOL	MIN	TYP	MAX	UNIT	REMARK
Lamp Voltage	VL	--	785	--	Vrms	IL=6.0mA
Lamp Current	IL	5.5	6.0	6.5	mArms	Note1,4
Lamp Frequency	FL	45	50	70	kHz	Note2,4
Starting Lamp Voltage	VS	1530	--	--	Vrms	Ta=0
		1280	--	--	Vrms	Ta=25
Lamp life Time	LT	40,000	50,000	--	hr	IL=6.0mA Continuous Operation

[Note1] Measurement Method of Lamp Current (the current meter is inserted in low voltage line)

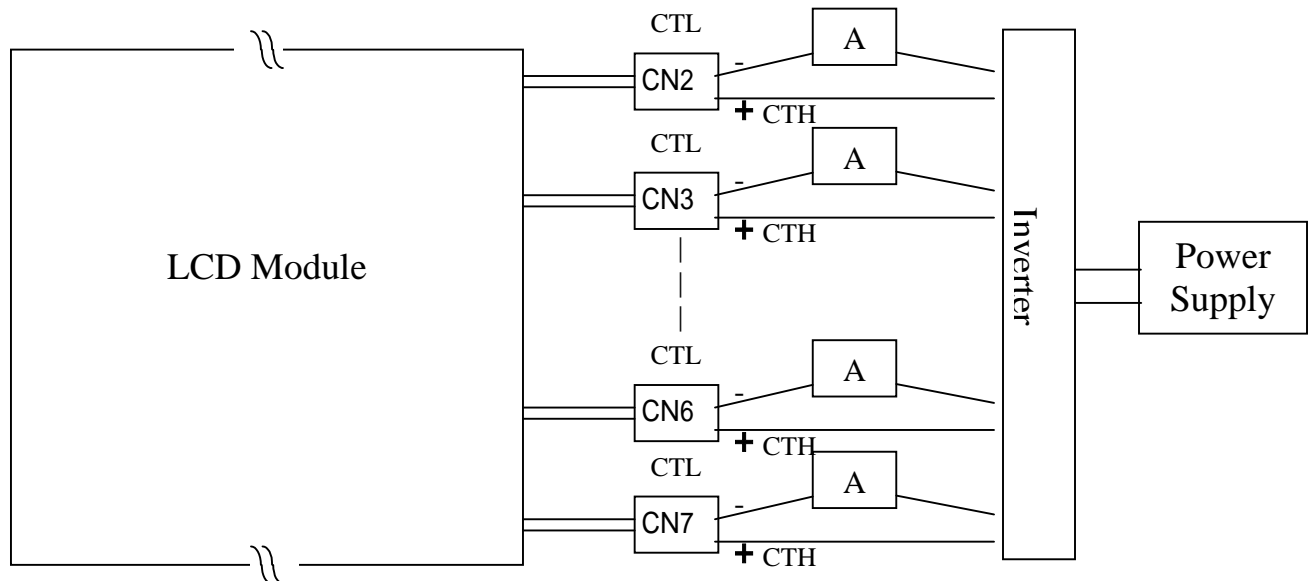

[Note2] The influence of lamp frequency

This frequency range can keep the electrical and optical character within 10% variation. Lamp frequency may interfere with horizontal synchronous frequency (or vitical synchronous frequency), and then cause ripple noise on the display. Therefore, please adjust the frequency of lamp input, be removed inveter from module as possible, or use electronic shielding between inverter and module to avoid the interference.

[Note3] Defination of the lamp life

The luminance reduced to 50% of initial value.

[Note4] Wave request

The degrees of unbalance: less than 10%

The ratio of wave height: less than  $2 \pm 10\%$

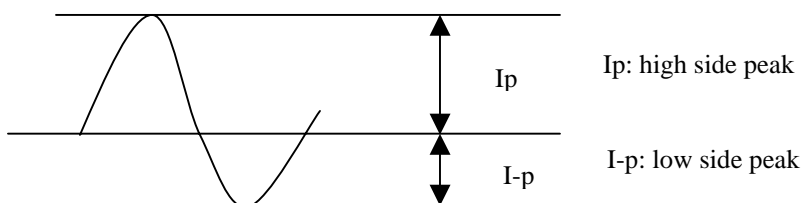

$$\text{The degrees of umbalance} = \frac{|I_p - I-p|}{I_{rms}} * 100(\%)$$

$$\text{The ratio of wave height} = \frac{I_p(\text{or } I-p)}{I_{rms}}$$

#### 4. INTERFACE PIN CONNECTION

(a) CN1(TFT-LCD signal)

Used connector: IL-FHR-F45S-HF-E3000 (JAE) or equivalent

Number	Symbol	Function
1	TEST	Should be open during operation (Internal test only)
2	TEST	Should be open during operation (Internal test only)
3	TEST	Should be open during operation (Internal test only)
4	VCC	5V
5	VCC	5V
6	RO0	Red odd data (LSB)
7	RO1	Red odd data
8	RO2	Red odd data
9	RO3	Red odd data
10	GND	GND
11	RO4	Red odd data
12	RO5	Red odd data
13	RO6	Red odd data
14	RO7	Red odd data (MSB)
15	GND	GND
16	GO0	Green odd data (LSB)
17	GO1	Green odd data
18	GO2	Green odd data
19	GO3	Green odd data
20	GND	GND
21	GO4	Green odd data
22	GO5	Green odd data
23	GO6	Green odd data
24	GO7	Green odd data (MSB)
25	GND	GND
26	BO0	Blue odd data (LSB)
27	BO1	Blue odd data
28	BO2	Blue odd data
29	BO3	Blue odd data
30	GND	GND
31	BO4	Blue odd data
32	BO5	Blue odd data
33	BO6	Blue odd data
34	BO7	Blue odd data (MSB)
35	GND	GND
36	NC	
37	GND	GND
38	HD	Horizontal sync
39	GND	GND
40	VD	Vertical sync
41	GND	GND
42	DENA	Data enable
43	GND	GND
44	CLK	Dot clock
45	GND	GND

## (b) CN2~7(Backlight)

Backlight-side connector : BHSR-02VS-1(JST)

Inverter-side connector : SM02B-BHSS-1(JST)

Pin No.	Symbol	Function
1	CTH	VLH (High voltage)
2	CTL	VLL (Low voltage)

**5. INTERFACE TIMING**

## (a) Timing Specifications

ITEM		SYMBOL	MIN	TYP	MAX	UNIT
DCLK *1) *4) *5)	Frequency	$f_{CLK}$	18	25	32	MHz
	Period	$t_{CLK}$	31.3	40	55	ns
	Low Width	$t_{WCL}$	0.3	-	-	ns
	High Width	$t_{WCH}$	0.3	-	-	ns
DATA *1) (R.G.B,DENA,HD,VD)	Set up Time	$t_{Ds}$	2.3	-	-	ns
	Hold Time	$t_{Dh}$	7.3	-	-	ns
DATA Enable DENA *3) *5)	Horizontal Valid	$t_{HV}$	640	640	640	$t_{CLK}$
	Horizontal Front Porch	$t_{HFP}$	4	8	-	$t_{CLK}$
	Horizontal Back Porch	$t_{HBP}$	6	40	-	$t_{CLK}$
	Horizontal Blank	-	-	144	-	
	Vertical Valid	$t_{VV}$	480	480	480	$t_H$
	Vertical Front Porch	$t_{VFP}$	0	2	-	$t_H$
	Vertical Back Porch	$t_{VBP}$	4	25	-	$t_H$
	Vertical Blank	-	-	29	-	$t_H$
HD *2) *4) *5)	Frequency	$f_H$	29.0	31.7	40.0	KHz
	Period	$t_H$	25.0	31.5	34.5	$\mu s$
	Low Width	$t_{WHL}$	20	96	-	$t_{CLK}$
VD *2) *5)	Frequency	$f_V$	55	60	75	Hz
	Period	$t_V$	13.3	16.7	18	ms
	Low Width	$t_{WVL}$	1	2	-	$t_H$

- 1) Data is latched at fall edge of DCLK in this specification.
- 2) Polarities of HD and VD are negative in this specification.
- 3) DENA(Data Enable)should always be positive polarity as shown in the timing specification.
- 4) DCLK should appear during all blanking period, and HD should appear during blanking period of frame cycle.

(b)Timing Chart

a. Pixel Timing Chart

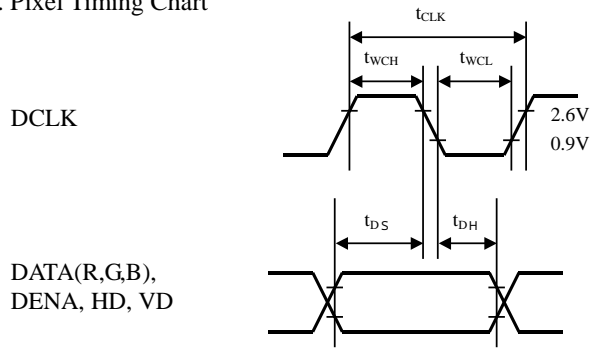

b. 水平時序圖(Horizontal Timing Chart)

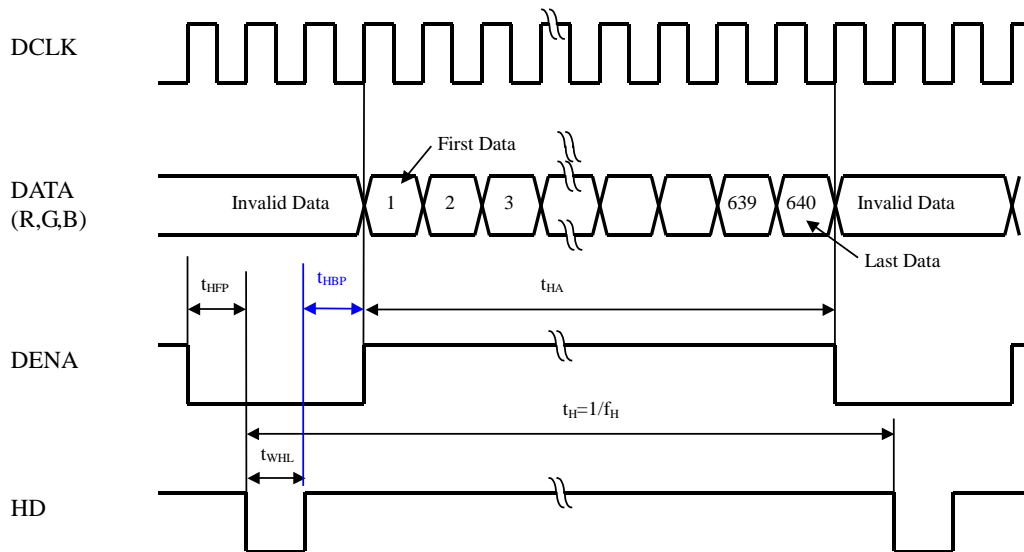

c. 垂直時序圖(Vertical Timing Chart)

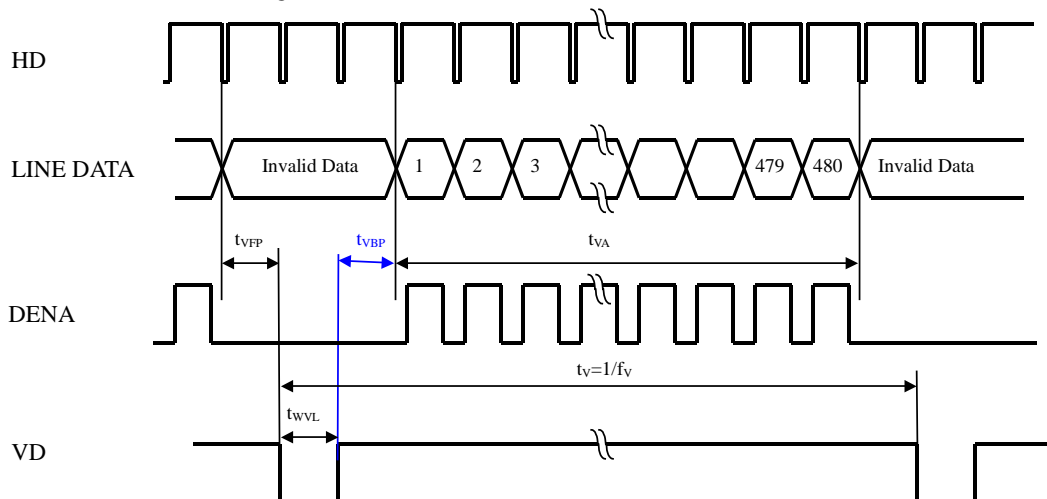

(c)Color Data Assignment

COLOR	INPUT DATA	R DATA							G DATA							B DATA								
		R7 MSB	R6	R5	R4	R3	R2	R1	R0 LSB	G7 MSB	G6	G5	G4	G3	G2	G1	G0 LSB	B7 MSB	B6	B5	B4	B3	B2	B1
BASIC COLOR	BLACK	0	0	0	0	0	0	0	0	0	0	0	0	0	0	0	0	0	0	0	0	0	0	0
	RED(255)	1	1	1	1	1	1	1	1	0	0	0	0	0	0	0	0	0	0	0	0	0	0	0
	GREEN(255)	0	0	0	0	0	0	0	0	1	1	1	1	1	1	1	0	0	0	0	0	0	0	0
	BLUE(255)	0	0	0	0	0	0	0	0	0	0	0	0	0	0	0	1	1	1	1	1	1	1	1
	CYAN	0	0	0	0	0	0	0	0	1	1	1	1	1	1	1	1	1	1	1	1	1	1	1
	MAGENTA	1	1	1	1	1	1	1	1	0	0	0	0	0	0	0	1	1	1	1	1	1	1	1
	YELLOW	1	1	1	1	1	1	1	1	1	1	1	1	1	1	1	0	0	0	0	0	0	0	0
	WHITE	1	1	1	1	1	1	1	1	1	1	1	1	1	1	1	1	1	1	1	1	1	1	1
RED	RED(0)	0	0	0	0	0	0	0	0	0	0	0	0	0	0	0	0	0	0	0	0	0	0	0
	RED(1)	0	0	0	0	0	0	0	1	0	0	0	0	0	0	0	0	0	0	0	0	0	0	0
	RED(2)	0	0	0	0	0	0	1	0	0	0	0	0	0	0	0	0	0	0	0	0	0	0	0
	RED(254)	1	1	1	1	1	1	1	0	0	0	0	0	0	0	0	0	0	0	0	0	0	0	0
	RED(255)	1	1	1	1	1	1	1	1	0	0	0	0	0	0	0	0	0	0	0	0	0	0	0
GREEN	GREEN(0)	0	0	0	0	0	0	0	0	0	0	0	0	0	0	0	0	0	0	0	0	0	0	0
	GREEN(1)	0	0	0	0	0	0	0	0	0	0	0	0	0	0	1	0	0	0	0	0	0	0	0
	GREEN(2)	0	0	0	0	0	0	0	0	0	0	0	0	0	1	0	0	0	0	0	0	0	0	0
	GREEN(254)	0	0	0	0	0	0	0	0	1	1	1	1	1	1	0	0	0	0	0	0	0	0	0
	GREEN(255)	0	0	0	0	0	0	0	0	1	1	1	1	1	1	1	0	0	0	0	0	0	0	0
BLUE	BLUE(0)	0	0	0	0	0	0	0	0	0	0	0	0	0	0	0	0	0	0	0	0	0	0	0
	BLUE(1)	0	0	0	0	0	0	0	0	0	0	0	0	0	0	0	0	0	0	0	0	0	0	1
	BLUE(2)	0	0	0	0	0	0	0	0	0	0	0	0	0	0	0	0	0	0	0	0	0	1	0
	BLUE(254)	0	0	0	0	0	0	0	0	0	0	0	0	0	0	0	1	1	1	1	1	1	1	0
	BLUE(255)	0	0	0	0	0	0	0	0	0	0	0	0	0	0	0	1	1	1	1	1	1	1	1

- 1) Definition of gray scale:  
 Color(n) : n indicates gray scale level.  
 Higher n means brighter level.
- 2) Data: 1-High, 0-Low.
- 3) This assignment is applied to both odd and even data.

(d) Pixel Mapping

D( 1, 1)	D( 2, 1)	---	D( X, 1)	---	D(639, 1)	D(640, 1)
D( 1, 2)	D( 2, 2)	---	D( X, 2)	---	D(639, 2)	D(640, 2)
		+		+		
D( 1, Y)	D( 2, Y)	---	D( X, Y)	---	D(639, Y)	D(640, Y)
		+		+		
D( 1,479)	D( 2,479)	---	D( X,479)	---	D(639,479)	D(640,479)
D( 1,480)	D( 2,480)	---	D( X,480)	---	D(639,480)	D(640,480)



### 6. BLOCK DIAGRAM

(a) TFT-LCD Module

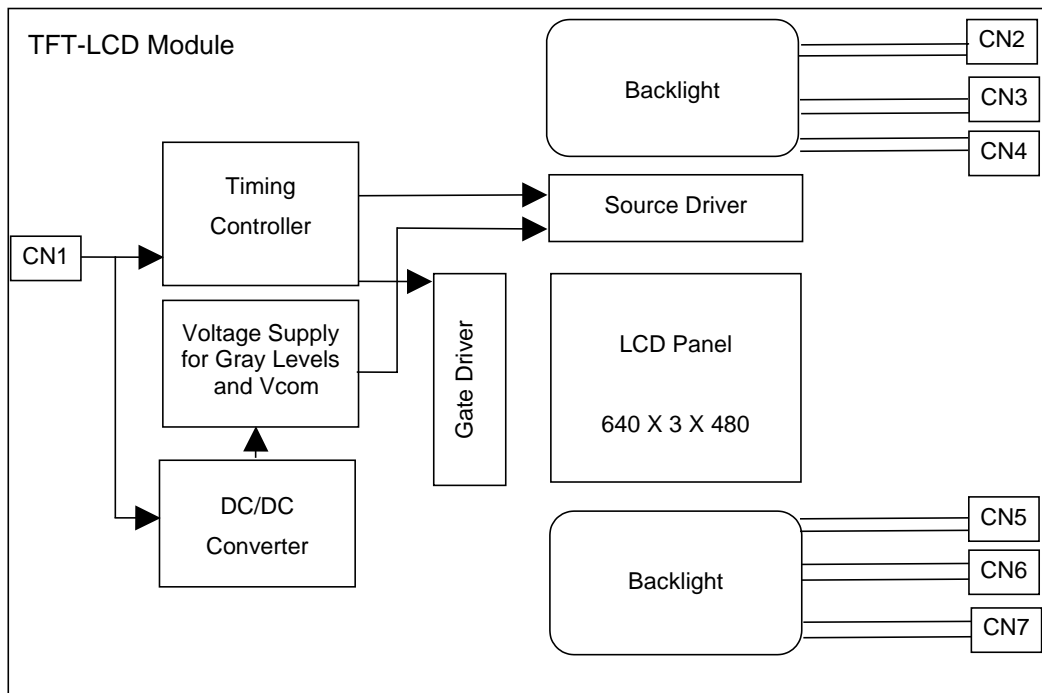

BACKLIGHT

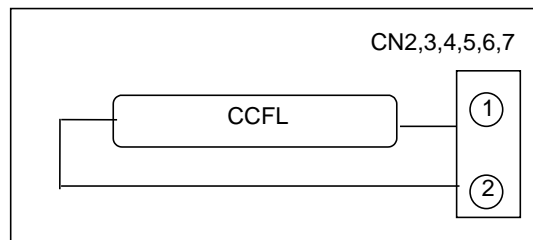

7. MECHANICAL SPECIFICATION

(a) Front side

Unit: mm

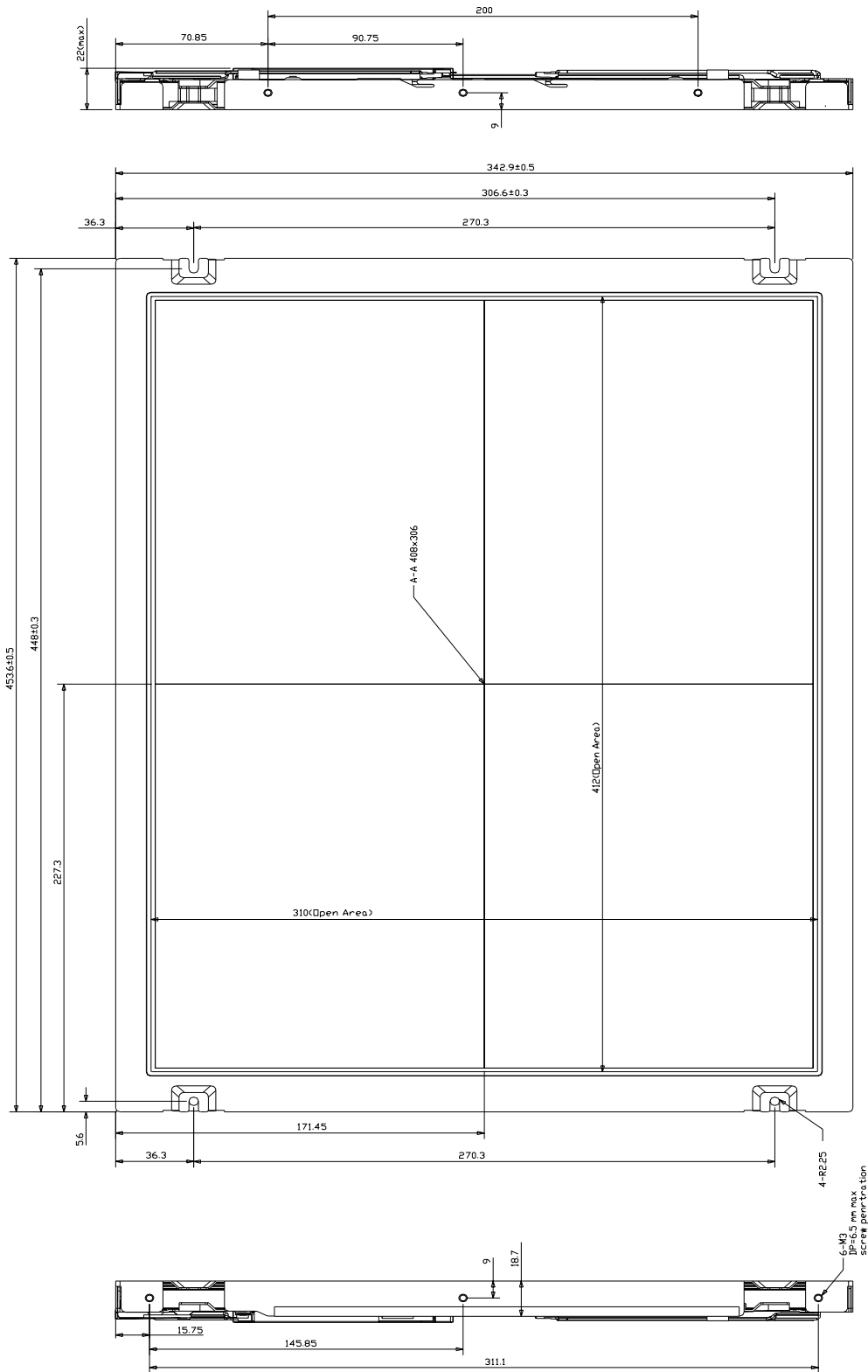

Tolerance is ±0.5mm unless noted

(b) Rear side (without inverter)

Unit: mm

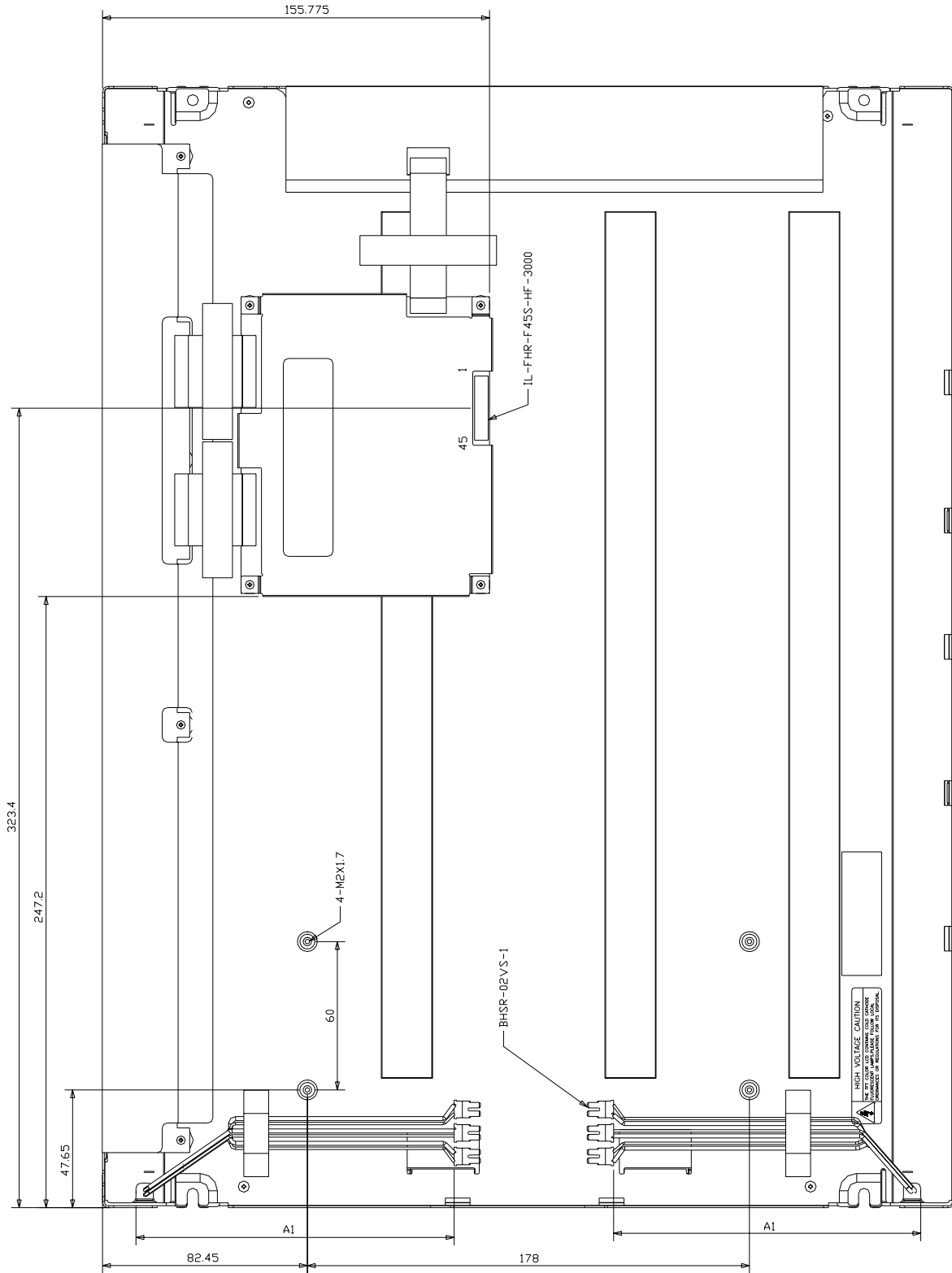

1. Tolerance is  $\pm 0.5$ mm unless noted.
2. The length of lamp wire(A) is  $150 \pm 10$ mm.

## 8.OPTICAL CHARACTERISTICS

Ta=25 , VCC=5.0V

ITEM	SYMBOL	CONDITION	MIN.	TYP.	MAX.	UNIT	Notes	
Contrast Ratio	CR	$\theta = \phi = 0^\circ$	400	500	--	-	*1)*2)*3)	
Luminance	Center	$\theta = \phi = 0^\circ$	400	500	--	cd/m <sup>2</sup>	*2)*3)	
	Uniformity	$\Delta Lw$	70 %	--	--	%	*2)*3)	
Response Time	tr	$\theta = \phi = 0^\circ$	--	6	10	ms	*3)*4)	
	tf	$\theta = \phi = 0^\circ$	--	10	20	ms	*3)*4)	
	Gray to Gray	$\theta = \phi = 0^\circ$		16		ms		
Viewing Angle	Horizontal	$\phi$	CR 5	--	-85~85	--	°	*2)*3)
	Vertical	$\theta$			-85~85			
	Horizontal	$\phi$	CR 10	-60~60	-75~75			*2)*3)
	Vertical	$\theta$		-50~55	-65~70		°	
Color Coordinates	Red	x	$\theta = \phi = 0^\circ$	(0.605)	(0.635)	(0.665)	-	*2)*3)
		y		(0.309)	(0.339)	(0.369)		
	Green	x		(0.235)	(0.265)	(0.295)		
		y		(0.574)	(0.604)	(0.634)		
	Blue	x		(0.112)	(0.142)	(0.172)		
		y		(0.050)	(0.080)	(0.110)		
	White	x		(0.253)	(0.283)	(0.313)		
		y		(0.267)	(0.297)	(0.327)		

- These items are measured by BM-5A(TOPCON) or CS-1000 (MINOLUTA) in the dark room (no ambient light) after putting panel in normal temperature 10 minutes and lighting the lamps 20 minutes.
- Brightness condition : BLON=High, VDIM=0V ( IL=6.0 mA)
- Definition of these measurement items are as follows:

\*1) Definition of Contrast Ratio

$$CR = \text{ON(White)Luminance} / \text{OFF(Black)Luminance}$$

\*2) Definition of luminance and contrast ratio measured position

(a) Measured the 5th point on the below(c) for Lw and CR

(b)  $Lw = [L(\text{Min}) / L(\text{Max})] \times 100\%$ 

(c) Measured points as below.

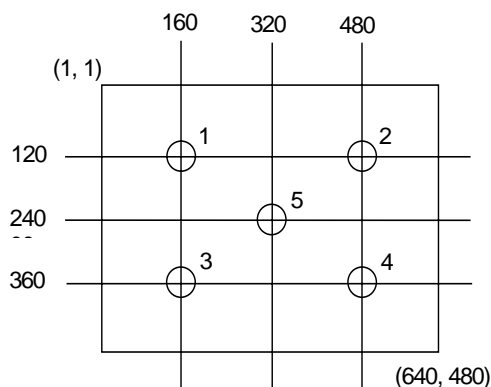

\*3) Definition of Viewing Angle(  $\theta$ ,  $\phi$  )

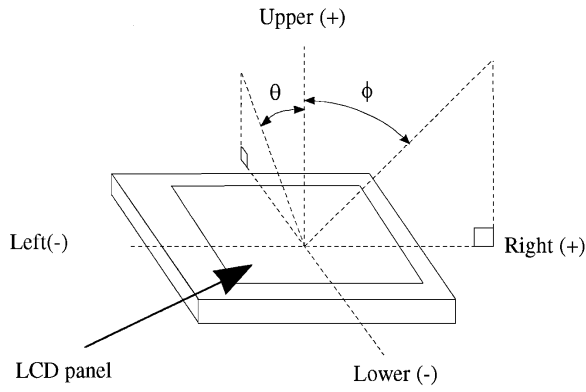

\*4) Definition of Response Time (White - Black)

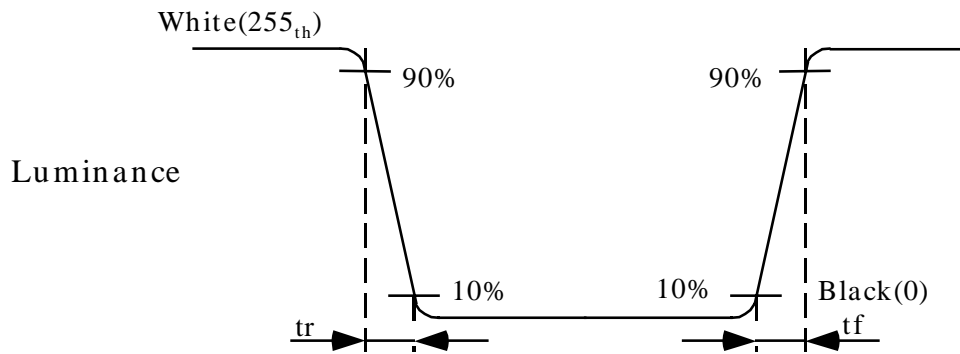

## 9.RELIABILITY TEST CONDITIONS

### (1)Temperature and Humidity

TEST ITEMS	CONDITIONS
HIGH TEMPERATURE HIGH HUMIDITY OPERATION	40 , 90%RH, 240h (No condensation)
HIGH TEMPERATURE HIGH HUMIDITY STORAGE	60 ,90% RH,48h (No condensation)
HIGH TEMPERATURE OPERATION	50 , 240h
LOW TEMPERATURE STORAGE	-20 , 240h
THERMAL SHOCK	BETWEEN -20 (1hr)AND 60 (1hr), 100 CYCLES
HIGH TEMPERATURE STORAGE	60 , 240h
LOW TEMPERATURE OPERATION	0 , 240h

### (2)Shock & Vibration

ITEMS	CONDITIONS
SHOCK (NON- OPERATION)	Shock level: 1470m/s <sup>2</sup> (150G) Waveform: half sinusoidal wave, 2ms Number of shocks: one shock input in each direction of three mutually perpendicular axes for a total of six shock inputs
VIBRATION (NON- OPERATION)	Vibration level: 9.8m/s <sup>2</sup> (1.0G) zero to peak Waveform: sinusoidal Frequency range: 5 to 500 Hz Frequency sweep rate: 0.5 octave/min Duration: one sweep from 5 to 500 to 5 Hz in each of three mutually perpendicular axis(each x,y,z axis: 1 hour, total 3 hours)

### (3)Judgment standard

The judgment of the above test should be made as follow:

Pass: Normal display image with no obvious non-uniformity and no line defect. Partial transformation of the module parts should be ignored.

Fail: No display image, obvious non-uniformity, or line defects.

## 10. HANDLING PRECAUTIONS FOR TFT-LCD MODULE

Please pay attention to the followings in handling- TFT-LCD products;

### 1 ASSEMBLY PRECAUTION

- (1) Please use the mounting hole on the module side in installing and do not beading or wrenching LCD in assembling. And please do not drop, bend or twist LCD module in handling.
- (2) Please design display housing in accordance with the following guide lines.
  - (2.1) Housing case must be destined carefully so as not to put stresses on LCD all sides and not to wrench module. The stresses may cause non-uniformity even if there is no non-uniformity statically.
  - (2.2) Keep sufficient clearance between LCD module back surface and housing when the LCD module is mounted. Approximately 1.0 mm of the clearance in the design is recommended taking into account the tolerance of LCD module thickness and mounting structure height on the housing.
  - (2.3) When some parts, such as, FPC cable and ferrite plate, are installed underneath the LCD module, still sufficient clearance is required, such as 0.5mm. This clearance is, especially, to be reconsidered when the additional parts are implemented for EMI countermeasure.
  - (2.4) Design the inverter location and connector position carefully so as not to give stress to lamp cable, or not to interface the LCD module by the lamp cable.
  - (2.5) Keep sufficient clearance between LCD module and the others parts, such as inverter and speaker so as not to interface the LCD module. Approximately 1.0mm of the clearance in the design is recommended.
- (3) Please do not push or scratch LCD panel surface with any-thing hard. And do not soil LCD panel surface by touching with bare hands. (Polarizer film, surface of LCD panel is easy to be flawed.)
- (4) Please do not press any parts on the rear side such as source TCP, gate TCP, control circuit board and FPCs during handling LCD module. If pressing rear part is unavoidable, handle the LCD module with care not to damage them.
- (5) Please wipe out LCD panel surface with absorbent cotton or soft cloth in case of it being soiled.
- (6) Please wipe out drops of adhesives like saliva and water on LCD panel surface immediately. They might damage to cause panel surface variation and color change.
- (7) Please do not take a LCD module to pieces and reconstruct it. Resolving and reconstructing modules may cause them not to work well.
- (8) Please do not touch metal frames with bare hands and soiled gloves. A color change of the metal frames can happen during a long preservation of soiled LCD modules.
- (9) Please pay attention to handling lead wire of backlight so that it is not tugged in connecting with inverter.

### 2 OPERATING PRECAUTIONS

- (1) Please be sure to turn off the power supply before connecting and disconnecting signal input cable.
- (2) Please do not change variable resistance settings in LCD module. They are adjusted to the most suitable value. If they are changed, it might happen LCD does not satisfy the characteristics specification.
- (3) Please consider that LCD backlight takes longer time to become stable of radiation characteristics in low temperature than in room temperature.
- (4) A condensation might happen on the surface and inside of LCD module in case of sudden change of ambient temperature.
- (5) Please pay attention to displaying the same pattern for very long time. Image might stick on LCD. If then, time going on can make LCD work well.
- (6) Please obey the same caution descriptions as ones that need to pay attention to ordinary

electronic parts.

### **3 PRECAUTIONS WITH ELECTROSTATICS**

- (1) This LCD module use CMOS-IC on circuit board and TFT-LCD panel, and so it is easy to be affected by electrostatics. Please be careful with electrostatics by the way of your body connecting to the ground and so on.
- (2) Please remove protection film very slowly on the surface of LCD module to prevent from electrostatics occurrence.

### **4 STORAGE PRECAUTIONS**

- (1) When you store LCDs for a long time, it is recommended to keep the temperature between 0 ~40 without the exposure of sunlight and to keep the humidity less than 90%RH.
- (2) Please do not leave the LCDs in the environment of high humidity and high temperature such as 60 ~ 90%RH.
- (3) Please do not leave the LCDs in the environment of low temperature; below -20 .

### **5 SAFETY PRECAUTIONS**

- (1) When you waste LCDS, it is recommended to crush damaged or unnecessary LCDs into pieces and wash them off with solvents such as acetone and ethanol, which should later be burned.
- (2) If any liquid leaks out of a damaged-glass cell and comes in contact with the hands, wash off thoroughly with soap and water.

### **6 OTHERS**

- (1) A strong incident light into LCD panel might cause display characteristics' changing inferior because of polarizer film, color filter, and other materials becoming inferior. Please do not expose LCD module direct sunlight Land strong UV rays.
- (2) Please pay attention to a panel side of LCD module not to contact with other materials in preserving it alone.
- (3) For the. packaging box, please pay attention to the followings:
  - (3.1) Packaging box and inner case for LCD are designed to protect the LCDs from the damage or scratching during transportation. Please do not open except picking LCDs up from the box.
  - (3.2) Please do not pile them up more than 5 boxes. (They are not designed so.) And please do not turn over.
  - (3.3) Please handle packaging box with care not to give them sudden shock and vibrations. And also please do not throw them up.
  - (3.4) Packing box and inner case for LCDs are made of cardboard. So please pay attention not to get them wet. (Such like keeping them in high humidity or wet place can occur getting them wet.)