

FEATURES

- ❑ 83 MHz Data Rate for HDTV Applications
- ❑ Supports Multiple Video Formats Bi-Directional Conversions:
 - 4:2:2:4
 - 4:4:4:4
 - R/G/B/Key
 - Y/U/V/Key
- ❑ Multiplexed and Non-multiplexed I/O Data
- ❑ User-Programmable:
 - 3 x 3 Colorspace Converter
 - LUT for Gamma Correction
 - I/O Bias Compensation
 - Bypass Capability
- ❑ 13-bit Data Path, Colorspace Converter Coefficients and Key Channel Scaling Coefficients
- ❑ 160-lead PQFP

DESCRIPTION

The LF3370 is a video format converter capable of operating at HDTV data rates. This device converts to and from any of the various SDTV/HDTV digital video formats by utilizing an internal 3 x 3 Matrix Multiplier and two 1:2 Interpolation/2:1 Decimation Half-Band Filters.

Using the Input Demultiplexer and Output Multiplexer, the LF3370 can accept and output interleaved or non-interleaved video. For example, R/G/B/Key data can be color space converted to Y/U/V/Key and down-converted to 4:2:2:4. By re-arranging the order of the functional sections, the opposite conversion can be achieved. The coefficients for

the 3 x 3 Matrix Multiplier are fully user programmable to support a wide range of color space conversions. The two Interpolation/Decimation Half-Band Filters are fully compliant with SMPTE 260M.

Input and Output Bias Adders are included for removing or adding a user-defined bias into the video signal. In addition, three programmable 1K x 13-bit Look-Up Tables (LUTs) have also been included for various uses such as gamma correction. A Scaler has been included on the Key Channel for scaling to a desired magnitude using user programmable coefficients.

Input signals can also be forced to user-defined levels for horizontal blanking. Furthermore, Round/Select/Limit (RSL) circuitry is provided at the end of various stages to provide the best possible conversions without color violations. For additional flexibility, the Halfband Filter can be individually bypassed using an internal programmable length delay. All control and coefficient registers are loaded through the LF Interface™.

This device operates at 3.3 V (5 V tolerant I/O) and is available in 160-lead PQFP package.

LF3370 BLOCK DIAGRAM

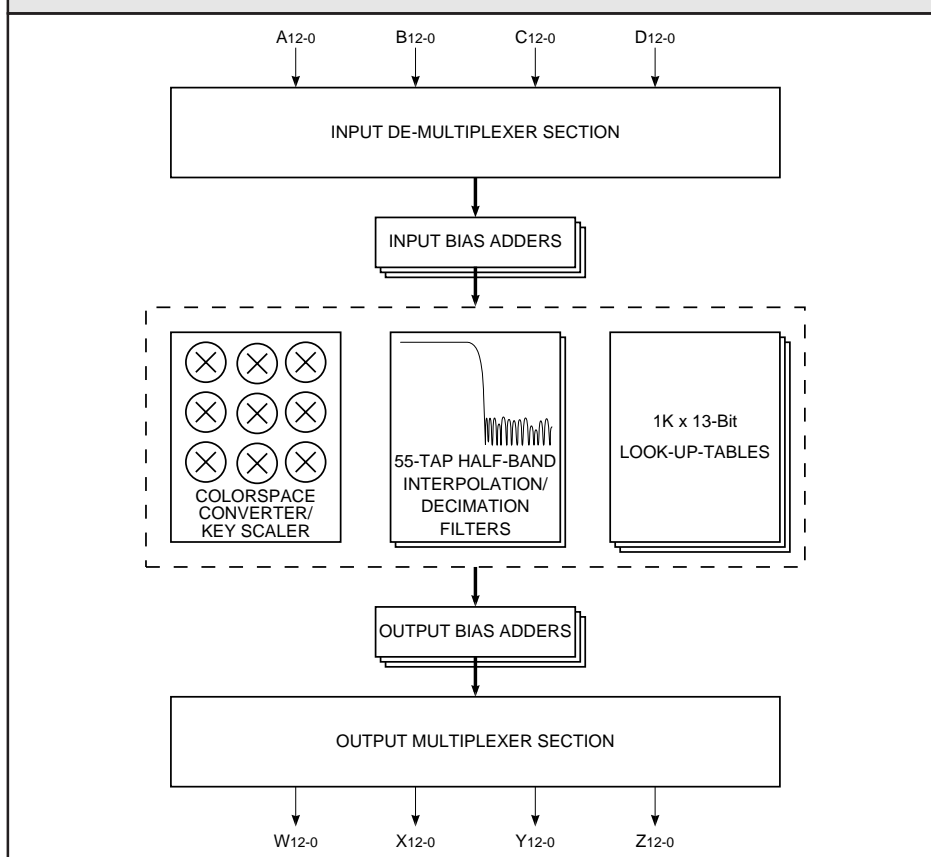
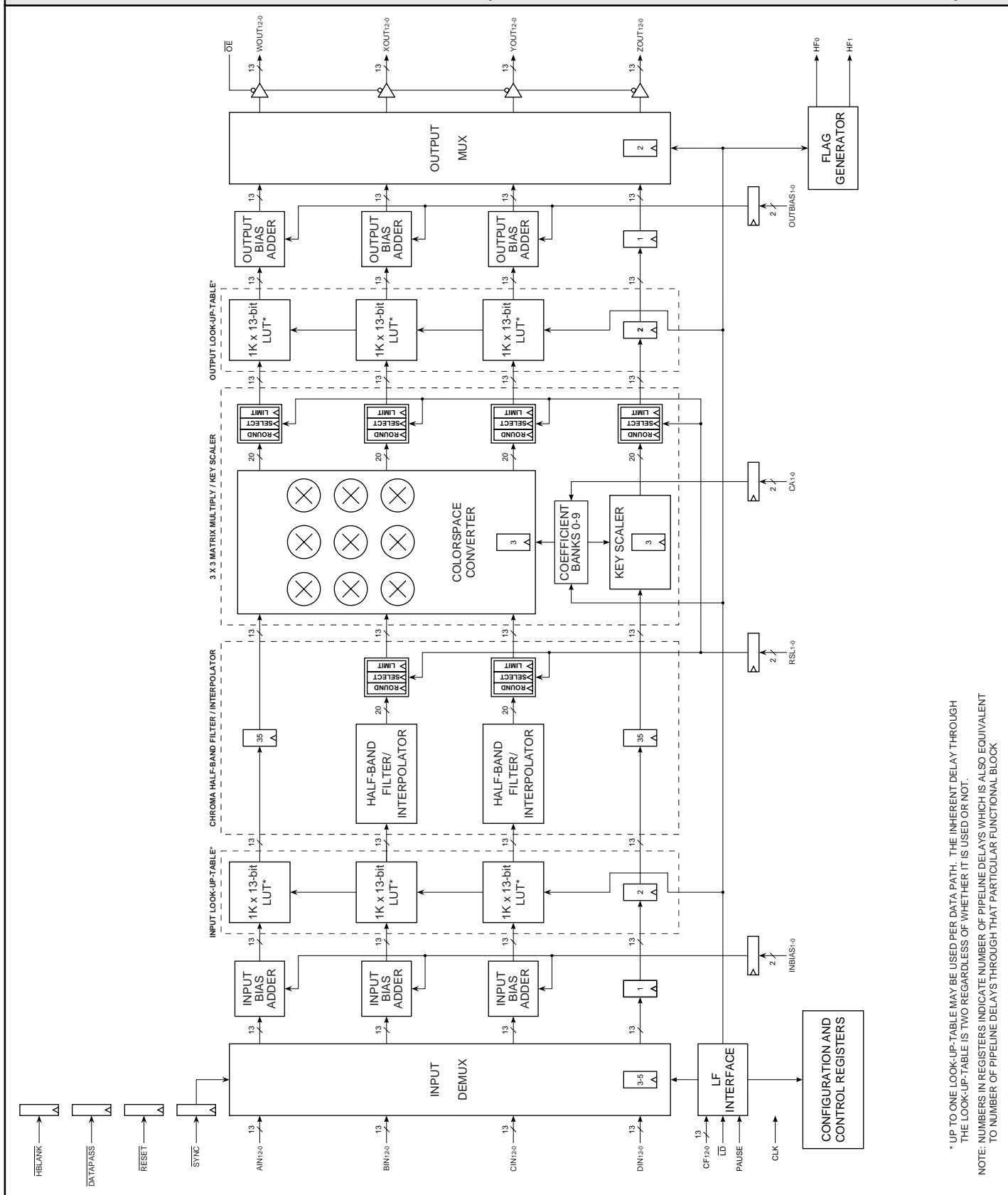
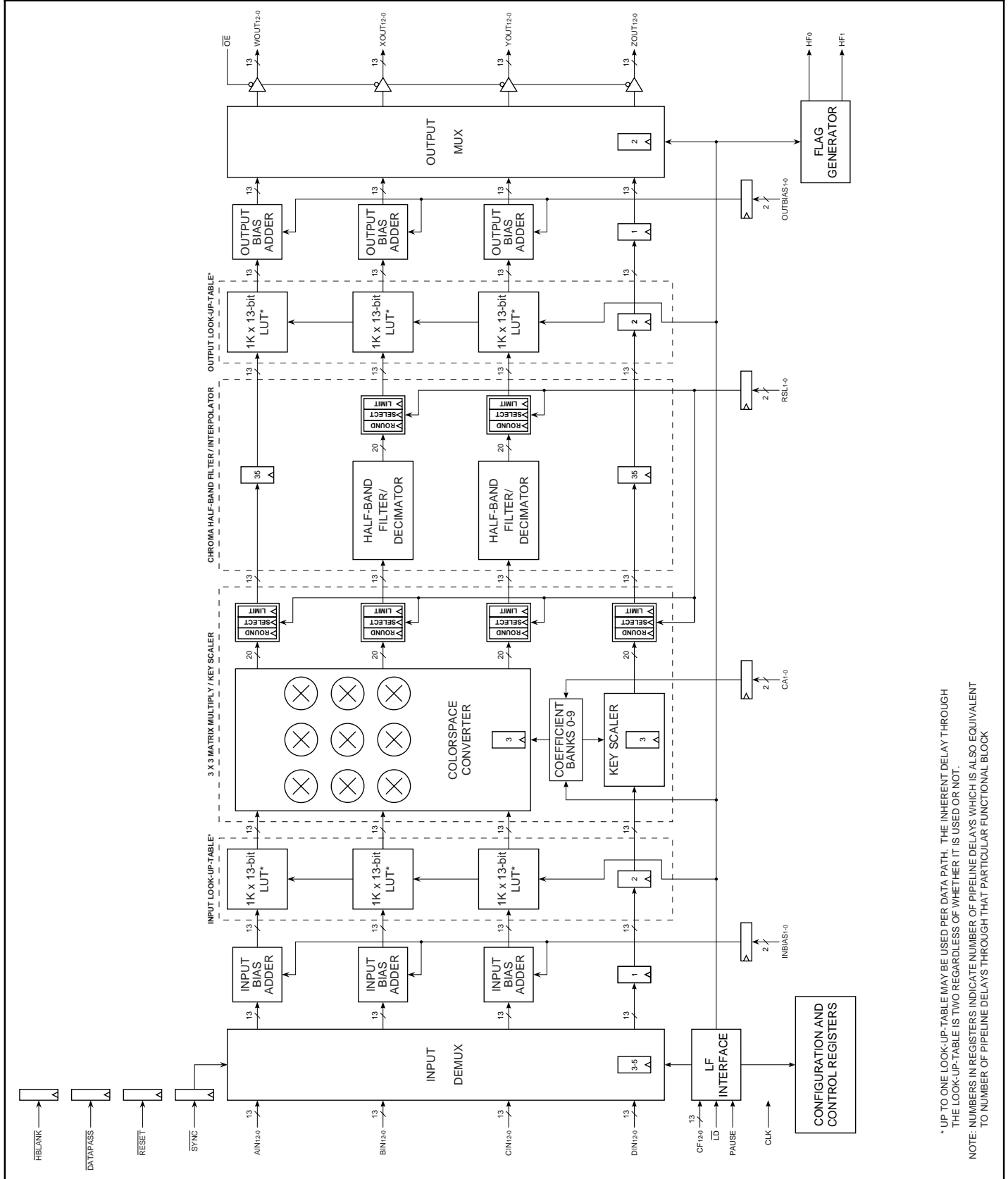

FIGURE 1. LF3370 FUNCTIONAL BLOCK DIAGRAM (HALF-BAND FILTER TO COLORSPACE ARRANGEMENT)



* UP TO ONE LOOK-UP-TABLE MAY BE USED PER DATA PATH. THE INHERENT DELAY THROUGH THE LOOK-UP-TABLE IS TWO REGARDLESS OF WHETHER IT IS USED OR NOT.
NOTE: NUMBERS IN REGISTERS INDICATE NUMBER OF PIPELINE DELAYS WHICH IS ALSO EQUIVALENT TO NUMBER OF PIPELINE DELAYS THROUGH THAT PARTICULAR FUNCTIONAL BLOCK

FIGURE 2. LF3370 FUNCTIONAL BLOCK DIAGRAM (COLORSPACE TO HALF-BAND FILTER ARRANGEMENT)



* UP TO ONE LOOK-UP-TABLE MAY BE USED PER DATA PATH. THE INHERENT DELAY THROUGH THE LOOK-UP-TABLE IS TWO REGARDLESS OF WHETHER IT IS USED OR NOT.
NOTE: NUMBERS IN REGISTERS INDICATE NUMBER OF PIPELINE DELAYS WHICH IS ALSO EQUIVALENT TO NUMBER OF PIPELINE DELAYS THROUGH THAT PARTICULAR FUNCTIONAL BLOCK

High-Definition Video Format Converter

SIGNAL DEFINITIONS

Power

VCC and GND

+3.3 V power supply. All power pins must be connected.

Clock

CLK — Master Clock

The rising edge of CLK strobes all enabled registers. To guarantee data integrity, a minimum of 25KHz must be maintained.

Inputs

A12-0, B12-0, C12-0, D12-0 — Data Inputs

A12-0, B12-0, C12-0, and D12-0 are the 13-bit registered data input ports. Data is latched on the rising edge of CLK.

CF12-0 — Coefficient Input

CF12-0 is used to address and load Colorspace/Key Scaler coefficient banks, Round/Select/Limit registers, and Configuration registers. Data present on CF12-0 is latched into the LF Interface™ on the rising edge of CLK when \overline{LD} is LOW.

CA1-0 — Coefficient Address

CA1-0 determines which of the four user-programmable Colorspace/Key Scaler Coefficients are used.

Outputs

W12-0, X12-0, Y12-0, Z12-0 — Data Outputs

W12-0, X12-0, Y12-0, and Z12-0 are the 13-bit registered data output ports. Outputs are updated on the rising edge of CLK.

HF1/HF0 — HBlank Flags

HF1 and HF0 are two general purpose flags used to indicate when a 20-bit counter reaches its user-defined terminal count; a HIGH to LOW transition of \overline{HBLANK} and/or \overline{RESET} will reset the flags.

Controls

\overline{LD} — Configuration Load

When \overline{LD} is LOW, data on CF12-0 is latched into the LF3370 LF Interface™ on the rising edge of CLK. When \overline{LD} is HIGH, data is not loaded into the LF Interface™. When enabling the LF Interface™ for data input, a latched HIGH to LOW transition of \overline{LD} is required in order for the input circuitry to function properly. Therefore, \overline{LD} must be set HIGH immediately after power up to ensure proper operation of the input circuitry.

\overline{SYNC} — Synchronization for data alignment

\overline{SYNC} control signal is required to properly synchronize the input demultiplexer, output multiplexer, and halfband filters to the data flowing through the LF3370. A latched HIGH to LOW transition tells the core which sample corresponds to a Cb/Cr sample for proper de-multiplexing and multiplexing. This signal will also synchronize the half-band filters into a decimation/interpolation sequence. This signal is latched on the rising edge of CLK.

$\overline{DATAPASS}$ — Datapass Mode

$\overline{DATAPASS}$ is used to place the LF3370 in a mode of operation that allows the user to pass data through the core (Input/Output Bias Adders, LUTs, Halfband Interpolator/Decimator, Colorspace/Key Scaler) without any processing. This signal is latched on the rising edge of CLK.

\overline{HBLANK} — Horizontal Blanking Control

\overline{HBLANK} is used for data replacement corresponding to user-selectable blanking levels. A HIGH to LOW transition resets the counter and the HFx flags. This signal is latched on the rising edge of CLK.

INBIAS1-0 — Input Bias Control

INBIAS1-0 determines which of the four user-programmable Input Bias registers are used to sum with the input data. These pins are latched on the rising edge of CLK.

OUTBIAS1-0 — Output Bias Control

OUTBIAS1-0 determines which of the four user-programmable Output Bias registers are used to sum with the output data. These pins are latched on the rising edge of CLK.

RSL1-0 — Round/Select/Limit Control

RSL1-0 determines which of the user-programmable Round/Select/Limit registers (RSL registers) are used in the RSL circuitry. A value of 00 on RSL1-0 selects RSL register 0. A value of 01 selects RSL register 1 and so on. RSL1-0 is latched on the rising edge of CLK.

\overline{OE} — Output Enable

When \overline{OE} is LOW, W12-0, X12-0, Y12-0, and Z12-0 are enabled for output. When \overline{OE} is HIGH, W12-0, X12-0, Y12-0, and Z12-0 are placed in a high-impedance state.

PAUSE — LF Interface™ Pause

When PAUSE is HIGH, the LF3370 LF Interface™ loading sequence is halted until PAUSE is returned to a LOW state. This effectively allows the user to load coefficients and control registers at a slower rate than the master clock. This pin is latched

High-Definition Video Format Converter

on the rising edge of CLK.

RESET — Reset

RESET is used to reset all programmable flags and line up clock edges during single muxed input or single muxed output events. RESET is used at power up or just after device configuration. This pin is latched on the rising edge of CLK.

LF3370 Device Initialization

This section explains how to initialize the device for proper operation. It also serves as a summary of all conditions that should be considered before using the device or for troubleshooting.

Configuration Register 0 and Configuration Register 1 must be loaded before operation of the device. If Core Bypassing is desired, Configuration Register 2 must be loaded before use. If use of the Half-Band Filters is desired, at least one Half-Band Filter RSL Register Set must be loaded and selected for each Half-Band Filter.

If use of the Matrix Multiplier/Key Scaler is desired, at least one Matrix Multiplier/Key Scaler RSL Register Set and coefficient address must be loaded and selected for each channel. If use of the Input Bias Adder is desired, at least one Input Bias Adder Register must be loaded and selected before use. If use of the Output Bias Adder is desired, at least one Output Bias Adder Register must be loaded and selected before use. If use of the Look-Up Table is desired, the Look-Up Table must be loaded before use.

When using a single channel input or output with interleaved video, SYNC and RESET should be used for proper initialization as shown in Figure 5. If 12 bits or less input data is desired, the input data should be shifted so the MSBs are aligned.

Input Demultiplexer

The input demultiplexer section acts as a buffer between the user's datapath and the

TABLE 1. INPUT/OUTPUT FORMATS				
Input Channel	Input Format*			
	4:4:4:4	4:2:2:4	4:2:2:4	4:2:2:4
A12-0	R	Y	Y	Y/Cb/Cr
B12-0	G	Cb	Cb/Cr	N/A
C12-0	B	Cr	N/A	N/A
D12-0	Key	Key	Key	Key
Output Channel	Output Format*			
	4:4:4:4	4:2:2:4	4:2:2:4	4:2:2:4
W12-0	R	Y	Y	Y/Cb/Cr
X12-0	G	Cb	Cb/Cr	N/A
Y12-0	B	Cr	N/A	N/A
Z12-0	Key	Key	Key	Key

* Not all input/output combinations are valid. If single channel interleaved video is used on either the input or output, the core clock will be running at CLK/2. Thus the maximum input, output, and core data rate must be considered.

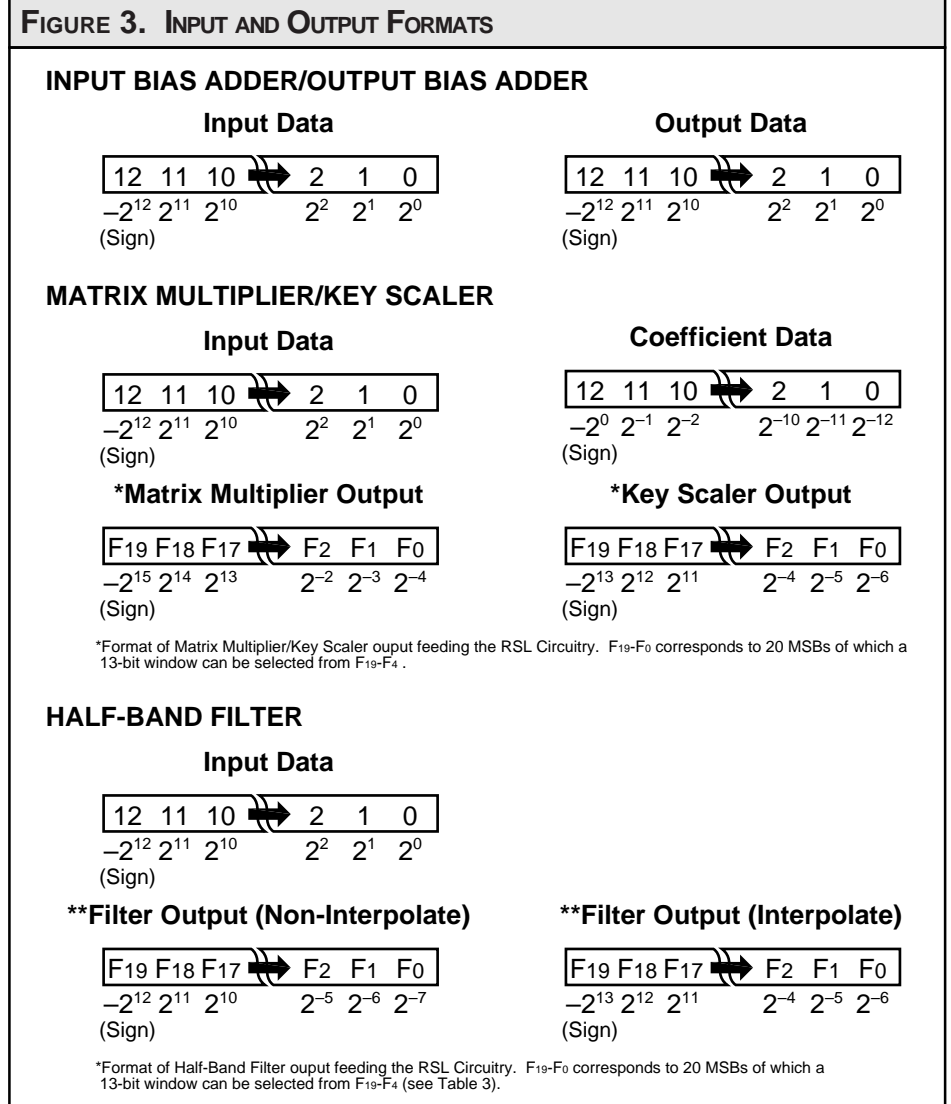

High-Definition Video Format Converter

LF3370's core. Data may be presented on input ports A12-0, B12-0, and C12-0 as three channels of non-interleaved input data, one channel non-interleaved and one channel interleaved input data, or one channel of interleaved data (see Table 1 for various video input schemes). D12-0 is the Key channel input port; the Key channel is

simply passed through the input demultiplexer with a latency that matches the other three channels.

If video data is non-interleaved and presented to input ports A12-0, B12-0, and C12-0, no demultiplexing is performed. The three channels are passed unmodified into the LF3370 core with a delay of 3 CLK

cycles. For this operation, bits 0 and 1 must both be set to 1 in Configuration Register 0 (see Table 5).

If video data is on two channels (see Figure 4), one channel of non-interleaved video and one channel of interleaved video, it is assumed that non-interleaved video is presented to input port A12-0 (i.e., Luma)

FIGURE 4. INPUT PROCESSING 4:2:2:4 (INTERLEAVED CHROMA ON CHANNEL B)

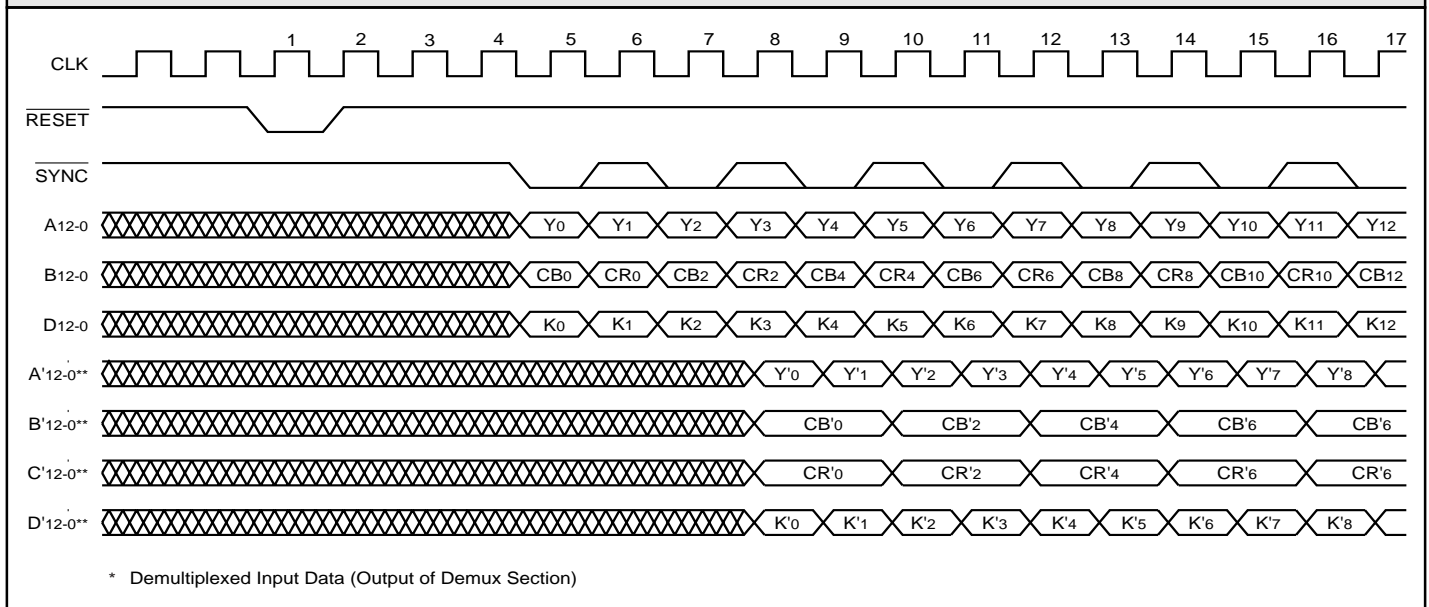
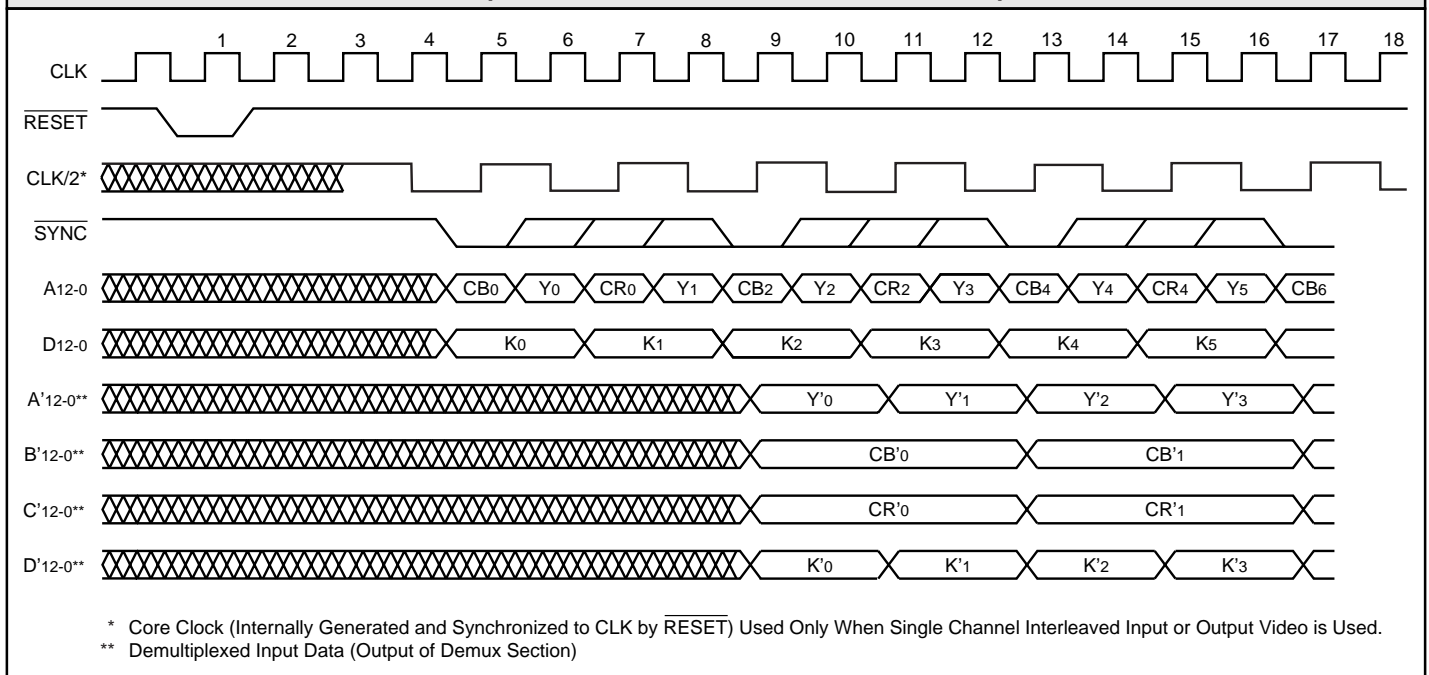

FIGURE 5. INPUT PROCESSING 4:2:2:4 (INTERLEAVED LUMA/CHROMA ON CHANNEL A)



High-Definition Video Format Converter

and interleaved video is presented to input port B12-0 (i.e., Chroma). The input demultiplexer, in this case, separates video data on B12-0 and outputs two channels of separated video into the LF3370 core with a delay of 4 CLK cycles. For this operation, bit 0 must be set to 0 and bit 1 must be set to 1 in Configuration Register 0 (see Table 5).

If 4:2:2 video data is on one channel interleaved (see Figure 5), it is assumed that interleaved video is presented to input port A12-0. The input demultiplexer, in this case, separates video data on A12-0 and outputs three channels of separated video into the LF3370 core with a delay of 5 CLK cycles. In this case, the core will run at half of the CLK rate and valid data will be output at at half of the CLK rate. For this operation, bit 0 must be set to 1 and bit 1 must be set to 0 in Configuration Register 0 (see Table 5).

All input demultiplexing operations are controlled by the latched HIGH to LOW transitions of SYNC which synchronizes the LF3370 core to the multiplexed input data (see SYNC discussion). It is impor-

tant that unused input ports be set either HIGH or LOW.

Output Multiplexer

The output multiplexer section can be configured in various ways to accommodate the video system. Bits 2 and 3 of Configuration Register 0 determines the number of output channels that the LF3370 will drive. Z12-0 is the Key channel output port; the Key channel simply gets passed through the output multiplexer with a latency that matches the other three channels.

If three separate output channels of non-interleaved video are desired, no multiplexing is performed. The three channels are passed through the output multiplexer unmodified on the output ports W12-0, X12-0, and Y12-0 with a delay of 2 CLK cycles. For this operation, bits 2 and 3 must both be set to 1 in Configuration Register 0 (see Table 5).

If one channel of non-interleaved video (i.e., Luma) and one channel of inter-

leaved video (i.e., Chroma) is desired (see Figure 6), non-interleaved video will be driven to the output port W12-0 and interleaved video will be driven to the output port X12-0 with a delay of 2 CLK cycles. For this operation, bit 2 must be set to 0 and bit 3 must be set to 1 in Configuration Register 0 (see Table 5).

If 4:2:2 interleaved video on one port is desired (see Figure 7), interleaved video will be driven to the output port W12-0 with a delay of 4 CLK cycles. For this operation, bit 2 must be set to 1 and bit 3 must be set to 0 in Configuration Register 0 (see Table 5).

All output multiplexing operations are initiated by the latched HIGH to LOW transitions of SYNC which synchronizes the multiplexed output data to the LF3370 core (see SYNC discussion).

SYNC

SYNC control signal is required to properly synchronize the input demultiplexer, output multiplexer, and

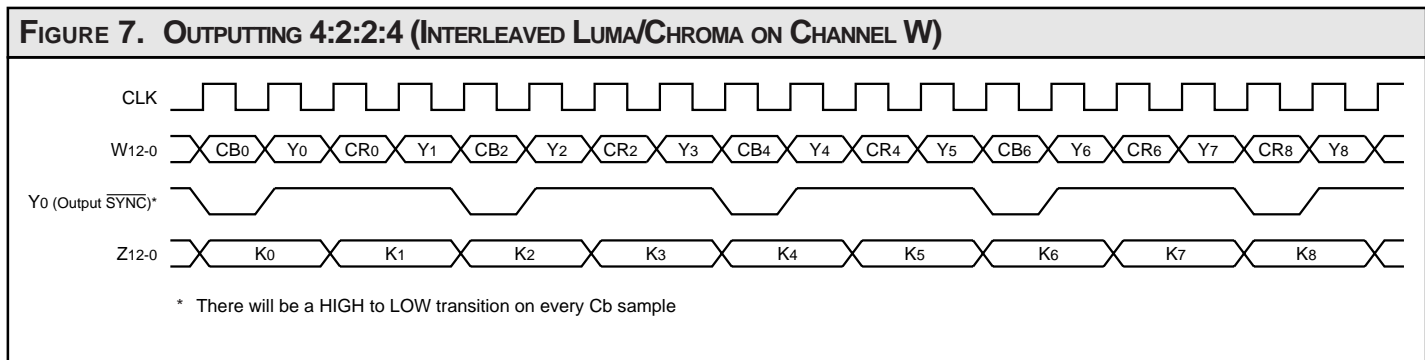
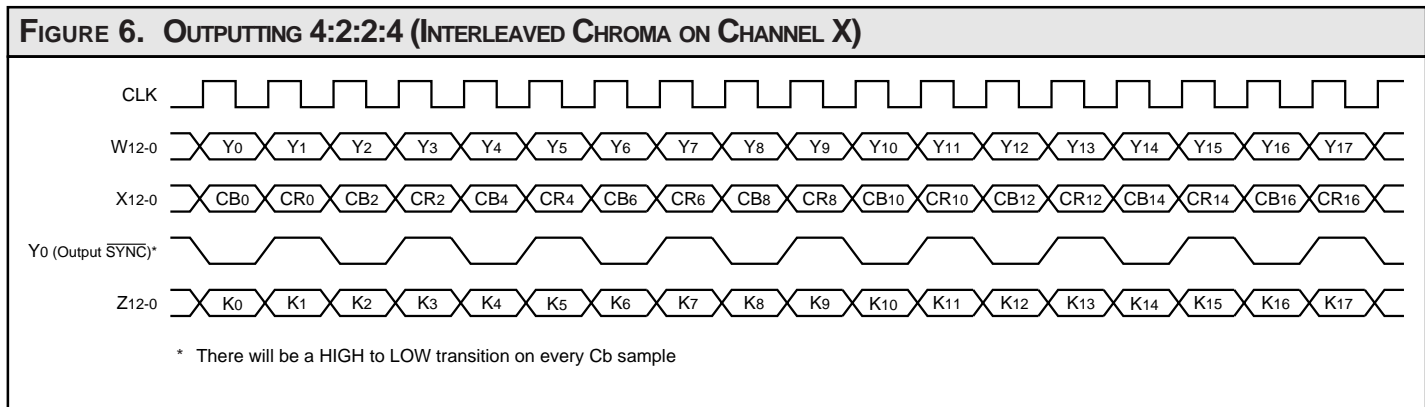

High-Definition Video Format Converter

halfband filters to the data flowing through the LF3370. A latched HIGH to LOW transition on SYNC control signal is needed to initialize the device to mark the beginning of valid data.

In addition, if 4:2:2 interleaved video data is desired for input or output, a HIGH to LOW transition on SYNC must be registered by a simultaneous rising edge of CLK and CLK/2. CLK/2 is an internal clock that must be synchronized to CLK by use of RESET only if the core is running at half the rate of CLK (see RESET discussion and Figures 4 & 5).

Furthermore, SYNC is used to identify one interleaved data set from another. For example, in the case of interleaved Chroma, Cb and Cr samples must be properly demultiplexed and synchronized for processing.

To differentiate a Cb sample from Cr, there needs to be a HIGH to LOW transition on SYNC on the first Cb sample (see Figure 4 & 5); SYNC can also be toggled on every Cb sample for re-synchronization.

In the case that Cb is the first valid data word, SYNC may be used only once in device initialization and kept low until re-

synchronization is desired. Therefore, when there is a HIGH to LOW transition on SYNC, the following is assumed: Cb will occur on the first LOW on SYNC that is latched, Cb will occur every two clock cycles if interleaved Chroma is presented to the input port B12-0, Cb will occur every 4 clock cycles if single channel 4:2:2 interleaved video is presented to the input port A12-0.

SYNC control signal is also used to synchronize the interpolation/decimation output data from the Half-Band Filter to the Output Multiplexer. This synchronization is done automatically.

RESET

RESET should be used when initializing the device for proper operation. It is used to synchronize the LF3370 core clock to the master clock. In the case that single channel 4:2:2 interleaved video data is desired either on the input or output, thus using only one input or one output port (not including Key data), the internal clock rate will be half (CLK/2) of the master clock rate (CLK). In this case, RESET is needed to synchronize the rising edge of CLK/2 to a known rising edge of CLK (see Figure 4). For example, after configuring the LF3370 and before

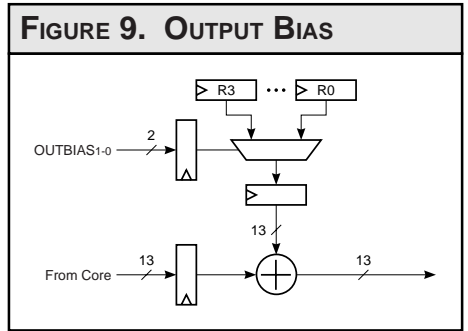
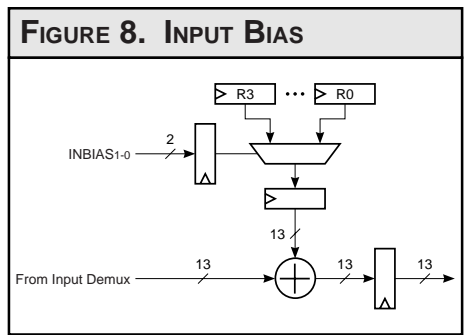

streaming valid data through the part, a RESET event should be used to align the clock edges (see Figure 4 & 5).

Furthermore, RESET will clear HF0 and HF1. A LOW state detected on RESET on a rising edge of clock will clear flags HF0 and HF1 on the following rising edge of clock. Please note HBLANK should be

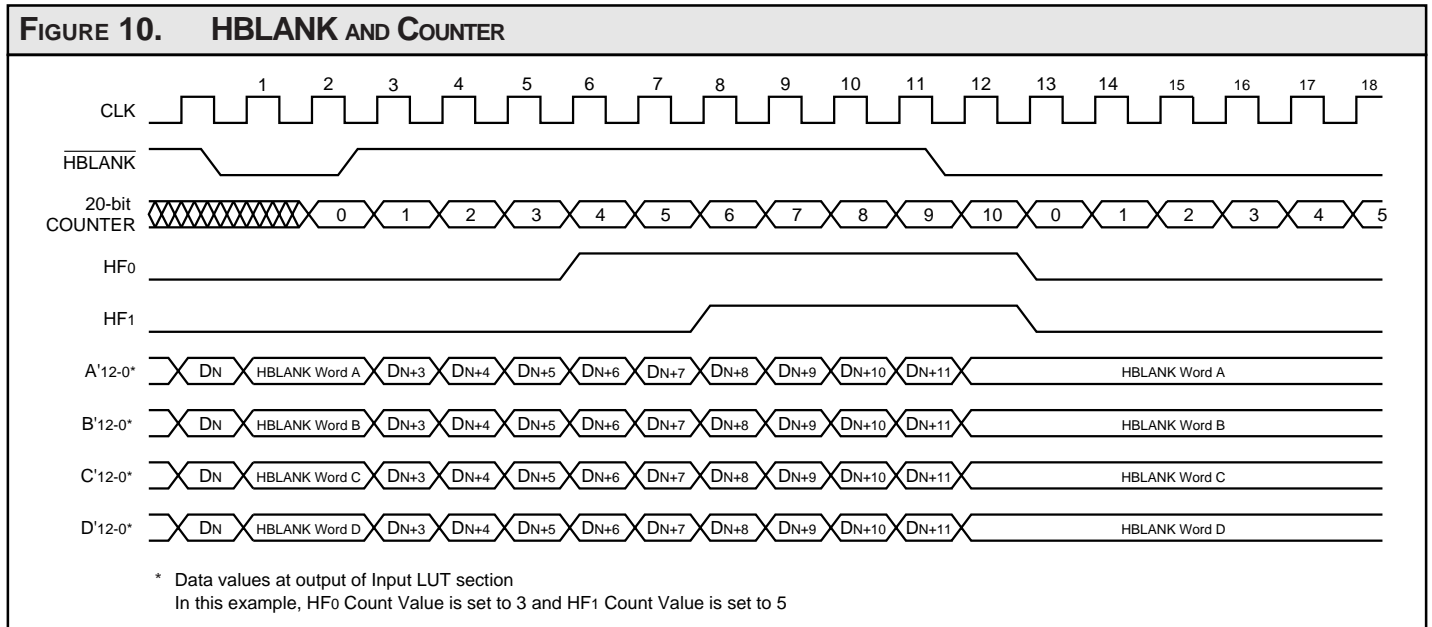

used to clear HF0 and HF1 during normal operation (see HBLANK discussion).

HBLANK

HBLANK is used to replace portions of the input data with user-defined blanking levels. When HBLANK is LOW, blanking level words are injected into the data stream immediately after the Input LUT section regardless of this section being used or not. While HBLANK is LOW, blanking level words are continually injected into the datapath with user-defined blanking words. Blanking words

are injected on the next rising clock edge when HBLANK is LOW. In addition, HBLANK clears flags HF0 and HF1 and resets a 20-bit incrementing counter (0-1,048,575). If a HIGH to LOW transition on HBLANK is detected on a rising edge of clock, HF0 and HF1 are cleared and the counter is reset on the following rising edge of clock (see Figure 10). Key Channel blanking may be independently enabled or disabled using Congifuration Register 1 (see Table 6).

HF0/HF1 and Counter

HF0 and HF1 are two independent flags that are set when the pre-programmed HF0 or HF1 count value is equal to the 20-bit incrementing counter value. For each flag, one user-defined 20-bit count value can be programmed. When HF0 or HF1 count value is equal to the counter value, HF0 or HF1 is set on the next rising edge of clock. Once the flags are set, they must be reset if they are needed again. The counter will increment by one at the rate of CLK and can be reset by HBLANK. The counter will continue to loop if not

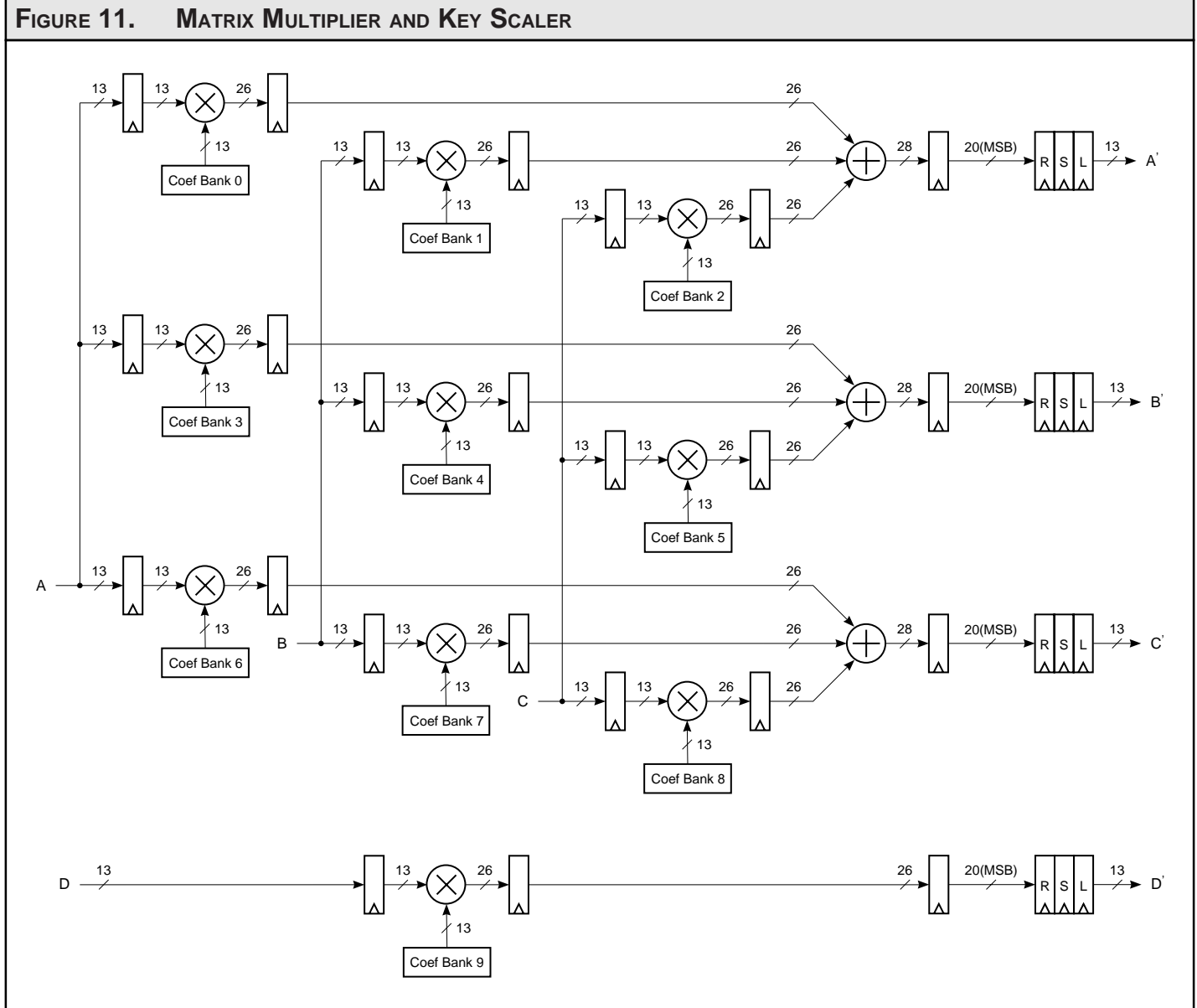

reset. HF0 and HF1 count value register loading is discussed in the LF Interface™. Please note, using HBLANK is the recommended way of clearing HF0 and HF1 flags but they can be cleared by RESET, normally performed during device initialization. RESET will not reset the counter.

Input/Output Bias Adder

The programmable Input/Output Bias Adders can be used to subtract or add a 13-bit offset to the data. Input and output data formats for the two sections are shown in Figure 3. By using INBIAS1-0, the user may select one of four programmed Input Bias Adder values (see Figure 8). By using OUTBIAS1-0, the user may select one of four programmed Output Bias Adder values (see Figure 9). A value of 00 on INBIAS1-0/OUTBIAS1-0 selects Input/Output Bias Adder Register 0. A value of 01 selects Input/Output Bias Adder Register 1 and so on. INBIAS1-0/OUTBIAS1-0 may be changed every clock cycle if desired. If a bias is not desired, then bits 11 & 12 of Configuration Register 1 can be set up to independently disable the input and output bias values. Thus, effectively zeroing the function. The total pipeline latency from the input to the output for each of the two sections is one CLK cycle. Input/Output Bias Adder Register loading is discussed in the LF Interface™ section.

3 x 3 Matrix Multiplier

Processing almost 550 million colors, three simultaneous 13-bit input and output channels are utilized to implement a 3 x 3-matrix multiplication (triple dot product). Each truncated 20-bit output is the sum of all three input words multiplied by the appropriate coefficients (see Figure 11). These outputs are then fed into the RSL circuitry (see Figure 13). Input/Output formats are shown in Figure 3.

For each of the nine multipliers, up to four user-defined 13-bit coefficients can be

programmed and selected by CA1-0. A value of 00 on CA1-0 selects Coefficient Set 0 on each of the 9 coefficient banks. A value of 01 selects Coefficient Set 1 and so on. CA1-0 may be changed every clock cycle if desired. Coefficient bank loading is discussed in the LF Interface™.

The total pipeline latency from the input of the Matrix Multiplier to the output of the RSL Circuitry is 6 CLK cycles and new output data is subsequently available every clock cycle thereafter.

If matrix multiplication is not desired, using the appropriate combination of coefficient values while keeping in mind bit weighting, an identity matrix may be set up to bypass the Matrix Multiplier section (see also First Operation Select in the Bypass Options discussion).

Key Scaler

The Key channel is equipped with a 13 x 13-bit Key Scaler (see Figure 11) producing a truncated 20-bit output which is then fed into the RSL circuitry (see Figure 13). Up to four user-defined 13-bit coefficients can be programmed and selected by CA1-0. Input/Output formats are shown in Figure 3.

The total pipeline latency from the input of the Key Scaler to the output of the RSL Circuitry is 6 CLK cycles and new output data is subsequently available every clock cycle thereafter. If scaling is not desired, load and select a Key Scaler Coefficient value of 1 (see also First Operation Select in the Bypass Options discussion).

Half-Band Filter

There are two internal Half-Band filters in the LF3370. These Half-Band filters can either interpolate, decimate, or pass through data found on channel B and channel C. Data on channel A and channel D in this section pass through a programmable 127 x 13-bit delay (see Bypass Section). The filter section (as shown in Figure 12) is a fixed-coefficient, linear-phase half-band (low-pass) interpolating/decimating digital filter. The filter in this section is a 55-tap transversal FIR with 13-bit coefficients as shown in Table 3. The frequency response (Figure 14) is in full compliance with SMPTE 260M. This section can be configured for 2:1 interpolation, 1:2 decimation, or pass-through mode by setting bits 5-8 in Configuration Register 0 (see Table 5). This section can also be placed before or after the matrix multi-

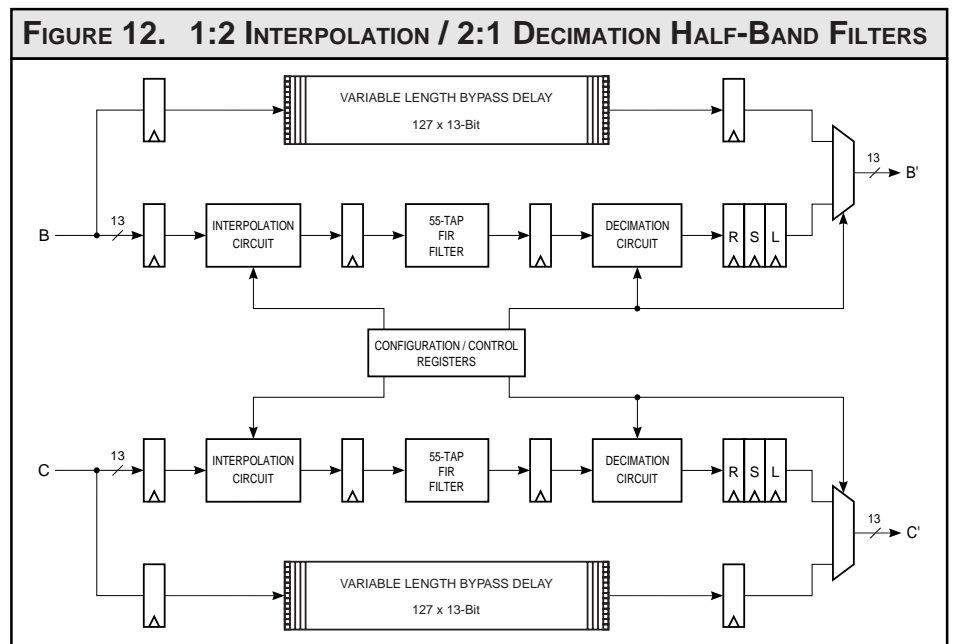

FIGURE 12. 1:2 INTERPOLATION / 2:1 DECIMATION HALF-BAND FILTERS

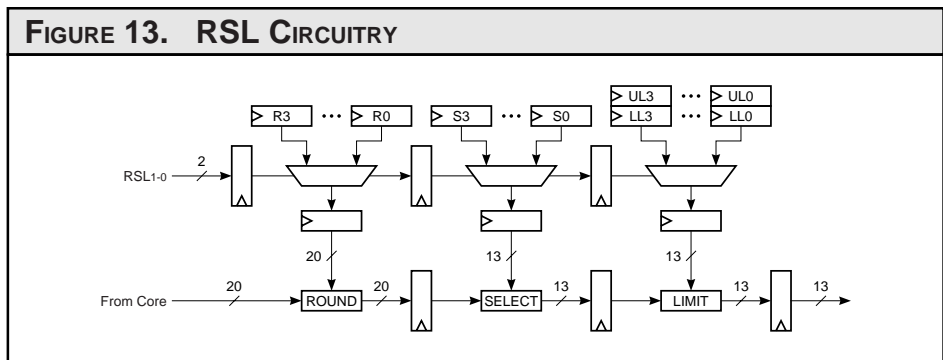

TABLE 2. SELECT FORMATS

SLCT1-0	S ₁₂	S ₁₁	S ₁₀	S ₉	S ₈	S ₇	S ₆	S ₅	S ₄	S ₃	S ₂	S ₁	S ₀
00	F ₁₆	F ₁₅	F ₁₄	F ₁₃	F ₁₂	F ₁₁	F ₁₀	F ₉	F ₈	F ₇	F ₆	F ₅	F ₄
01	F ₁₇	F ₁₆	F ₁₅	F ₁₄	F ₁₃	F ₁₂	F ₁₁	F ₁₀	F ₉	F ₈	F ₇	F ₆	F ₅
10	F ₁₈	F ₁₇	F ₁₆	F ₁₅	F ₁₄	F ₁₃	F ₁₂	F ₁₁	F ₁₀	F ₉	F ₈	F ₇	F ₆
11	F ₁₉	F ₁₈	F ₁₇	F ₁₆	F ₁₅	F ₁₄	F ₁₃	F ₁₂	F ₁₁	F ₁₀	F ₉	F ₈	F ₇

plier by setting bit 4 in Configuration Register 0 (see Table 5). The maximum input and output clock rate this section can operate at is the CLK rate. The total internal pipeline latency from the input to the output of this section (including RSL circuitry) as shown in Figure 12 is 6 cycles.

To perform interpolation, the input data rate of this section will be half of CLK rate. Please note the maximum output data

rate is the CLK rate. To perform decimation, the output data rate of this section will be half of the input data rate. One output sample is obtained for every two input samples.

Once an impulse is clocked into the Half-Band Filter section, the 55-value output response begins after 8 clock cycles and ends after 62 clock cycles. The pipeline latency from the input of an impulse to its

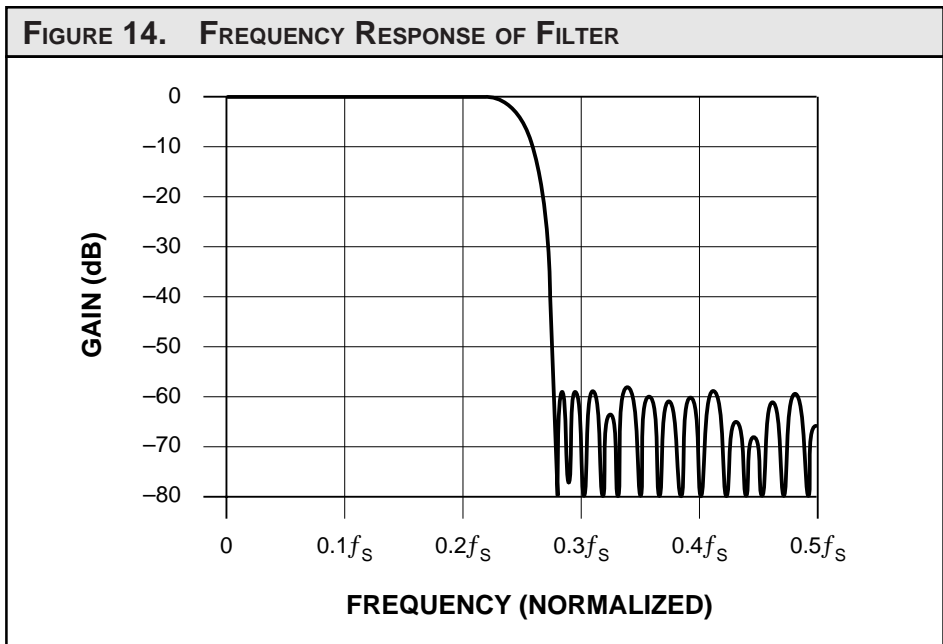

corresponding output peak is 35 clock cycles.

The input/output formats are always in two's complement format as shown in Figure 3. In Interpolate Mode, the gain of the Half-Band Filter is halved (due to half of the input samples being padded with zeros). A right shifted Select window is required to maintain an overall filter gain of 1. It is possible that ringing on the filter's output could cause the high order bit (bit F18 in Figure 3 - Interpolate Filter Output Bit Weighting) to become HIGH. If a right shifted Select window is used, this F18 bit becomes the sign bit of the Selected window – and the output is erroneously considered negative. To ensure that no overflow conditions occur, an internal Limiter within each Half-Band Filter monitors its output. During Interpolate mode, this Limiter clamps the output word to 3FFFFH (20-bit maximum positive value ÷ 2) or C0000H (20-bit maximum negative value ÷ 2) if a positive or negative overflow occurs respectively. The internal 24-bits of the Half-Band Filter are truncated to 20-bits and then passed to the Round section of the RSL circuitry; see RSL section for further details. This section is fully bypassable by use of programmable delays (see Bypass Options section for further details).

Look-Up Table

Three optional programmable Input/Output 1K x 13-bit LUTs have been provided for Channels A, B, and C for various uses such as Gamma Correction. There are NOT actually two LUTs per channel as shown in Figures 1 and 2; only one LUT per channel can be selected for use at any given time. The latency through a LUT section is 2 cycles. This latency is present on the datapath regardless of whether the LUT is in use or not.

When using a LUT, the appropriate addressed value will be passed as an

High-Definition Video Format Converter

output of the LUT section. The Gamma LUT address can be chosen from any of the 4 possible 10-bit words that are 'window' selected from the 13-bit Input data bus. Configuring the desired LUT address selector position is accomplished by programming bits 10 & 9 of Configuration Register 1. Once the LUT Select Data position is programmed, it is meant to control all three Gamma LUTs. Therefore, the address selector positions of the three LUTs cannot be independently controlled. LUT loading is discussed in the LF Interface™ section.

Rounding

The rounding circuitry found in the Matrix Multiplier and Half-Band Filter sections work in the same manner. The truncated 20 MSBs from the Matrix Multiplier or Half-Band Filter output may be rounded by being added to the contents of one of the four Round Registers (see Figure 13). Each round register is 20 bits wide and user-programmable. This allows the Matrix Multiplier's or Half-Band Filter's output to be rounded to any precision required. RSL1-0 determines which of the four Round Registers are used in each Rounding Circuitry. A value of 00 on RSL1-0 selects Round Register 0. A value of 01 selects Round Register 1 and so on. RSL1-0 may be changed every clock cycle if desired. If rounding is not desired, the user must load and select a Round Register with value of 0. Round Register loading is discussed in the LF Interface™ section.

Selecting

The selecting circuitry found in the Matrix Multiplier and Half-Band Filter sections work in the same manner. The output word of the Matrix Multiplier and Half-Band Filter feeding the RSL circuitry is the 20 MSBs. However, only 13 bits may be sent to the next section. Therefore, the Select Register determines which 13-bits are passed. There are four select registers; RSL1-0 determines which of the four Select

Registers are used in each Select Circuitry (see Table 2). A value of 00 on RSL1-0 selects Select Register 0. A value of 01 selects Select Register 1 and so on. RSL1-0 may be changed every clock cycle if desired. This allows the 13-bit window to be changed every clock cycle. Select Register loading is discussed in the LF Interface™ section.

Limiting

The Limiting Circuitry found in the Matrix Multiplier and Half-Band Filter sections work in the same manner. The Limit Registers determine the valid range of output values for each of these two sections. There are four 13-bit Limit Registers for each section. RSL1-0 determines which of the four Limit Registers are used in each Limiting Circuitry (see Figure 13). A value of 00 on RSL1-0 selects Limit Register 0. A value of 01 selects Limit Register 1 and so on.

Each Limit Register contains an upper and lower limit value. If the value fed to

the Limiting Circuitry is less than the lower limit, the lower limit value is passed as the Matrix Multiplier section's or Half-Band filter section's output. If the value fed to the Limiting Circuitry is greater than the upper limit, the upper limit value is passed as the Matrix Multiplier section's or Half-Band filter section's output.

RSL1-0 may be changed every clock cycle if desired thus allowing the limit range to be changed every clock cycle. When loading limit values into the device, the upper limit must be greater than the lower limit. The most negative and most positive values you can load into the Limit Registers are 0FFFH and 1000H. Limit Register loading is discussed in the LF Interface™ section.

LF Interface™

The LF Interface™ is used to load the Configuration Registers, Matrix Multiplier/Key Scaler Coefficient Banks, Look-Up Tables, Input/Output Bias registers, RSL registers, HF0 and HF1 Count Values, and Horizontal Blanking Levels.

TABLE 3. HALF-BAND FILTER IMPULSE RESPONSE

TAP	Impulse Response Out (Non-Interpolated Bit Weighing) 20-bit (MSB) Filter Out (HEX)	Decimal Equivalent
1, 55	FFE35	-0.0008755
2, 54	0	0
3, 53	002D2	0.0013771
4, 52	0	0
5, 51	FFB5C	-0.00226593
6, 50	0	0
7, 49	00725	0.0034885
8, 48	0	0
9, 47	FF508	-0.0053558
10, 46	0	0
11, 45	00F95	0.0076084
12, 44	0	0
13, 43	FEA10	-0.01071167
14, 42	0	0
15, 41	01E59	0.0148182
16, 40	0	0
17, 39	FD6A8	-0.02018738
18, 38	0	0
19, 37	0393E	0.0279503
20, 36	0	0
21, 35	FAF1B	-0.0394993
22, 34	0	0
23, 33	0798D	0.05935097
24, 32	0	0
25, 31	F2BD2	-0.10360334
26, 30	0	0
27, 29	28B30	0.3179626
28 (center)	401BC	0.500846862

FIGURE 15. BYPASS BLOCK DIAGRAM

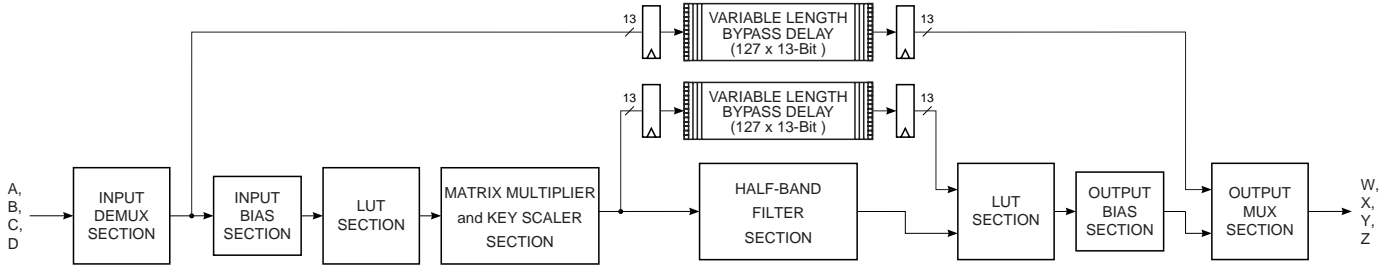

In this example, the Matrix-Multiplier/Key Scaler Section feeds the Half-Band Filter Section. This arrangement is reversible.

FIGURE 16. CORE BYPASS

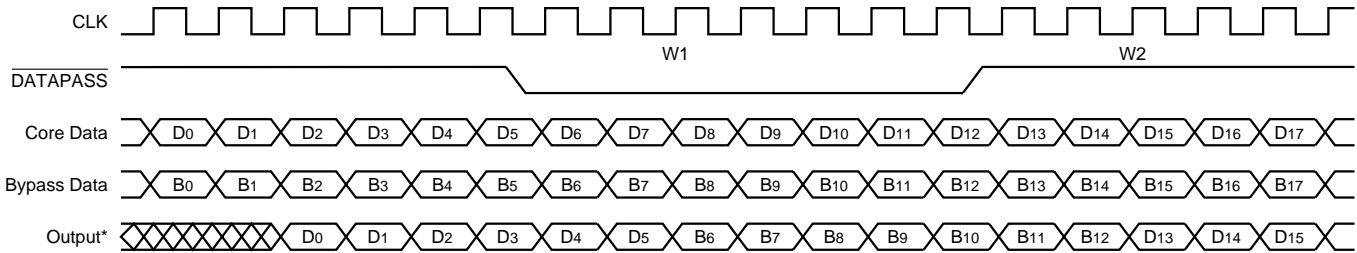

* In this example, the Output Multiplexer is in a mode where the delay through the section is 2 CLK cycles. Only one channel is shown in this example, however, the other three channels behave in the same manner. The example assumes that the bypass RAM length is set to the length of the core data path.
 W1: Bypass data is output to the output port and replaces core data.
 W2: Core data is output to the output port and replaces bypass data.

TABLE 4. CONFIGURATION/CONTROL REGISTERS ADDRESSING SUMMARY

DESCRIPTION	ADDRESS RANGE (HEX)
Coefficient Registers	0000 - 0003
Configuration Registers	0200 - 020A
Look-Up Table - Channel 'A'	0300
Look-Up Table - Channel 'B'	0400
Look-Up Table - Channel 'C'	0500
Input Bias Registers - Channel 'A'	0600 - 0603
Input Bias Registers - Channel 'B'	0700 - 0703
Input Bias Registers - Channel 'C'	0800 - 0803
Output Bias Registers - Channel 'A'	0900 - 0903
Output Bias Registers - Channel 'B'	0A00 - 0A03
Output Bias Registers - Channel 'C'	0B00 - 0B03
HF0 Count Value	0C00
HF1 Count Value	0D00
Matrix Mult. RSL Registers - Channel 'A'	0E00 - 0E03
Matrix Mult. RSL Registers - Channel 'B'	0F00 - 0F03
Matrix Mult. RSL Registers - Channel 'C'	1000 - 1003
Key Scaler RSL Registers	1100 - 1103
Half-Band Filter RSL Registers - Channel 'B'	1200 - 1203
Half-Band Filter RSL Registers - Channel 'C'	1300 - 1303

\overline{LD} is used to enable and disable the LF Interface™. When \overline{LD} goes LOW, the LF Interface™ is enabled for data input. The first value fed into the interface on CF12-0 is an address which determines what the interface is going to load (see Table 4). For example, to load address Bias Adder Register 2 of the channel B Output Bias Adder, the first data value into the LF Interface™ should be 0A02H. To load RSL Register 1 for the Keyscaler RSL, the first data value should be 1101H. The first address value should be loaded into the interface on the same clock cycle that latches the HIGH to LOW transition of \overline{LD} . The next value(s) loaded into the interface are the data value(s) which will be stored in the bank or register defined by the address value. When loading coefficient banks, the interface will expect ten values to be loaded into the device after the address value. The ten values are coefficients 0 through 8 and the Keyscale coefficient. When loading Configuration or Bias Registers, the interface will expect one value after the address value. When loading RSL registers, the interface will

expect four values after the address value. When loading gamma look-up tables, the interface will expect 1024 values after the address value. When loading HBLANK flag counts, the interface will expect 2 values after the address value.

The coefficient banks, configuration registers, RSL registers, etc., are not loaded with data until all data values for the specified address are loaded into the LF Interface. In other words, the coefficient banks are not written until all ten coefficients have been loaded into the LF Interface™. A RSL register is not written to until all four data words are loaded. After the last data value is loaded, the interface will expect a new address value on the next clock cycle. After the next address value is loaded, data loading will begin again as previously discussed.

PAUSE allows the user to effectively slow the rate of data loading through the LF Interface™. When PAUSE is HIGH, the LF Interface™s held until PAUSE is returned LOW. Figure 19 shows the effects of PAUSE while loading Matrix Multiplier/Key Scaler coefficients.

Table 28 shows an example of loading a bias value into the Input Bias Adder Register. In this example, a bias value of 007FH is loaded into the Channel 'C' Input Bias Adder Register 1 (0B01H).

Table 29 shows an example of loading a bias value into the Output Bias Adder Register. In this example, a bias value of 0010H is loaded into Channel 'A' Output Bias Adder Register 3 (0903H).

Table 30 shows an example of loading data into the Matrix Multiplier/Key Scaler Coefficient Banks. In this example, the following values are loaded into Coefficient Register Set 2 (0002H): 0000H, 0001H, 0002H, 0003H, 0004H, 0005H, 0006H, 0007H, 0008H, and 0009H.

Table 31 shows an example of loading the HF0 Flag Count Value. In this example, a 20-bit HF0 Flag Count Value of B3C27H is loaded into the HF0 Flag Count Value

TABLE 5. CONFIGURATION REGISTER 0 – ADDRESS 200H

BITS	FUNCTION	DESCRIPTION
1-0	Video Input Format	00 : Reserved 01 : Single Channel Interleaved Video 10 : Dual Channel Interleaved Video 11 : 3 Channel Non-Interleaved Video
3-2	Video Output Format	00 : Reserved 01 : Single Channel Interleaved Video 10 : Dual Channel Interleaved Video 11 : 3 Channel Non-Interleaved Video
4	Functional Arrangement	0 : Filter Feeds Matrix Multiplier 1 : Matrix Multiplier Feeds Filter
6-5	Half-Band Filter Control Channel 'B'	00 : Pass Through Filter 01 : Interpolate 10 : Decimate 11 : Bypass Filter
8-7	Half-Band Filter Control Channel 'C'	00 : Pass Through Filter 01 : Interpolate 10 : Decimate 11 : Bypass Filter
9	First Operation Select	0 : Normal Order of Operations 1 : Select First Operation Only
12-10	Reserved	Must be Set to Zero

TABLE 6. CONFIGURATION REGISTER 1 – ADDRESS 201H

BITS	FUNCTION	DESCRIPTION
1-0	Look-Up Table Control Channel 'A'	00 : Disable Look-Up Table 01 : Enable Look-Up Table on Input 10 : Enable Look-Up Table on Output 11 : Reserved
3-2	Look-Up Table Control Channel 'B'	00 : Disable Look-Up Table 01 : Enable Look-Up Table on Input 10 : Enable Look-Up Table on Output 11 : Reserved
5-4	Look-Up Table Control Channel 'C'	00 : Disable Look-Up Table 01 : Enable Look-Up Table on Input 10 : Enable Look-Up Table on Output 11 : Reserved
6	HBLANK Control 'Key' Channel	0 : Disable Horizontal Blanking Option During HBLANK Period 1 : Enable Horizontal Blanking Option During HBLANK Period
8-7	Data Bypass Mode 'W' Output Channel Mux Control	00 : Output Channel 'A' to W12-0 01 : Output Channel 'B' to W12-0 10 : Output Channel 'C' to W12-0 11 : Output Channel 'D' to W12-0
10-9	Look-Up Table Input Address Selection Control	00 : Select Address Data [9:0] 01 : Select Address Data [10:1] 10 : Select Address Data [11:2] 11 : Select Address Data [12:3]
11	Input Bias Disable	0 : Enable Input Bias 1 : Disable Input Bias
12	Output Bias Disable	0 : Enable Output Bias 1 : Disable Output Bias

High-Definition Video Format Converter

Register (0C00H). The HF1 Flag Count Value is loaded in the same manner using the appropriate address.

Table 32 shows an example of loading Round/Select/Limit values. In this example, Channel 'A' Matrix Multiplier Register Set 0 (0E00H) is loaded with a 20-bit Round value of 00020H, a 2-bit Select value of 10H, a 13-bit Upper Limit value of 0FFFH, and a 13-bit Lower Limit value of 1001H. Other RSL registers are loaded in the same manner using the appropriate address.

Table 33 shows an example of loading a Configuration Register. In this example, Configuration Register 0 (0200H) is loaded with 00AEH. This will setup the Input Section to handle Luma on input port A12-0 and interleaved Chroma on the input port B12-0. The Output Section is setup to output RGB on the output ports W12-0, X12-0, Y12-0. The 'functional arrangement' is setup in such a way that the Half-Band Filter section is placed before the Matrix Multiplier section. The Half-Band Filters are setup for 1:2 interpolation and 'normal order of operations' is selected.

BYPASS OPTIONS

Core Bypass

At all times during the normal operation of the LF3370, video data on channels A, B, C, and D are simultaneously being fed from the output of the Input Demultiplexer into the programmable Core Bypass Delay (see Figure 15). This allows users to switch between processed video and unprocessed (bypassed) data on-the-fly.

There is a separate Core Bypass Delay for each channel. Each Core Bypass Delay can be programmed for a length of 2 up to 129 CLK cycles for delay matching between the bypass path and the core as well as other operations. The Core Bypass Delay bypasses the Input Bias, Input LUT, Half-Band Filter, Matrix Multiplier/Key

Scaler Section, and Output Bias and feeds the Output Multiplexer. Loading Configuration Register 2 programs the length of all four Core Bypass Delays (see Table 7).

A LOW state detected on $\overline{\text{DATAPASS}}$ on a rising edge of clock will output bypassed data to the output port on the following rising edge of CLK (see Figure X). In addition, any of the four bypassed channels can be passed to the 'W' output channel during a 'bypass' event. For this operation, use bits 7 and 8 of Configuration Register 1 (see Table 6).

Half-Band Filter Bypass

At all times, while data is being fed into the Half-Band Filter section, channels A, B, C, and Key are fed into programmable length delays. When the Half-Band Filter(s) are set to filter bypass mode, that particular channel passes through a programmable delay and is not filtered. Since there are only two Half-Band Filters in this section found on channels B and C, channels A and Key are always passed through their respective programmable delays.

Please note, when using a single channel video input or video output (interleaved 4:2:2), the Core Bypass Delay must be

TABLE 7. CONFIGURATION REGISTER 2 – ADDRESS 202H		
BITS	FUNCTION	DESCRIPTION
6-0	Core Bypass Delay Length	Length of Core Bypass Delay Minus 2
12-7	Reserved	Must be Set to Zero

TABLE 8. CONFIGURATION REGISTER 3 – ADDRESS 203H		
BITS	FUNCTION	DESCRIPTION
6-0	Channel 'A' Filter Section Bypass Delay Length	Length of Filter Bypass Delay Minus 2
12-7	Reserved	Must be Set to Zero

TABLE 9. CONFIGURATION REGISTER 4 – ADDRESS 204H		
BITS	FUNCTION	DESCRIPTION
6-0	Channel 'B' Filter Section Bypass Delay Length	Length of Filter Bypass Delay Minus 2
12-7	Reserved	Must be Set to Zero

TABLE 10. CONFIGURATION REGISTER 5 – ADDRESS 205H		
BITS	FUNCTION	DESCRIPTION
6-0	Channel 'C' Filter Section Bypass Delay Length	Length of Filter Bypass Delay Minus 2
12-7	Reserved	Must be Set to Zero

TABLE 11. CONFIGURATION REGISTER 6 – ADDRESS 206H		
BITS	FUNCTION	DESCRIPTION
6-0	Key Channel Filter Section Bypass Delay Length	Length of Filter Bypass Delay Minus 2
12-7	Reserved	Must be Set to Zero

High-Definition Video Format Converter

TABLE 12. CONFIGURATION REGISTER 12 – ADDRESS 207

BITS	FUNCTION	DESCRIPTION
12-0	Channel 'A' Blanking Word	Channel 'A' Blanking Level Word

TABLE 13. CONFIGURATION REGISTER 13 – ADDRESS 208

BITS	FUNCTION	DESCRIPTION
12-0	Channel 'B' Blanking Word	Channel 'B' Blanking Level Word

TABLE 14. CONFIGURATION REGISTER 14 – ADDRESS 209

BITS	FUNCTION	DESCRIPTION
12-0	Channel 'C' Blanking Word	Channel 'C' Blanking Level Word

TABLE 15. CONFIGURATION REGISTER 15 – ADDRESS 20A

BITS	FUNCTION	DESCRIPTION
12-0	Channel 'D' Blanking Word	Channel 'D' Blanking Level Word

programmed to double the length $[(\text{desired length} \times 2) - 2]$ to properly align data due to the core running at half the CLK rate.

First Operation Select

'First Operation Select' is a bypassing option where you select to use the first functional block (Half-Band Filter or Matrix Multiplier/Key Scaler) in any given arrangement. If the device was arranged in such a way that the Half-Band Filter section fed the Matrix Multiplier/Key Scaler section and 'First Operation Select' was enabled, the Half-Band Filter section will be used and the Matrix Multiplier/Key Scaler section will be bypassed.

If the device was arranged in such a way that the Matrix Multiplier/Key Scaler section fed the Half-Band Filter section and 'First Operation Select' was enabled, the Matrix Multiplier/Key Scaler section will be used - its output will be routed directly to the output LUT section. Unlike in other bypassing options, the total pipeline latency of the LF3370 is reduced by the appropriate delay. If the Half-Band Filter section was bypassed by this method, the overall pipeline latency should be reduced by 35 CLK cycles. If the Matrix Multiplier section was bypassed by this method, the overall pipeline latency should be reduced by 6 CLK cycles. This function is implemented by configuring bit 9 of Configuration Register 0. The 'Functional Arrangement' of the device is determined by configuring bit 4 of Configuration Register 0.

TABLE 16. CHANNEL 'A' INPUT BIAS REGISTERS	
REGISTER	ADDRESS (HEX)
0	0600
1	0601
2	0602
3	0603

TABLE 17. CHANNEL 'B' INPUT BIAS REGISTERS	
REGISTER	ADDRESS (HEX)
0	0700
1	0701
2	0702
3	0703

TABLE 18. CHANNEL 'C' INPUT BIAS REGISTERS	
REGISTER	ADDRESS (HEX)
0	0800
1	0801
2	0802
3	0803

TABLE 19. CHANNEL 'A' OUTPUT BIAS REGISTERS	
REGISTER	ADDRESS (HEX)
0	0900
1	0901
2	0902
3	0903

TABLE 20. CHANNEL 'B' OUTPUT BIAS REGISTERS	
REGISTER	ADDRESS (HEX)
0	0A00
1	0A01
2	0A02
3	0A03

TABLE 21. CHANNEL 'C' OUTPUT BIAS REGISTERS	
REGISTER	ADDRESS (HEX)
0	0B00
1	0B01
2	0B02
3	0B03

TABLE 22. CHANNEL 'A' MATRIX MULT. RSL REGISTERS	
REGISTER	ADDRESS (HEX)
0	0E00
1	0E01
2	0E02
3	0E03

TABLE 23. CHANNEL 'B' MATRIX MULT. RSL REGISTERS	
REGISTER	ADDRESS (HEX)
0	0F00
1	0F01
2	0F02
3	0F03

TABLE 24. CHANNEL 'C' MATRIX MULT. RSL REGISTERS	
REGISTER	ADDRESS (HEX)
0	1000
1	1001
2	1002
3	1003

TABLE 25. 'KEY' CHANNEL MATRIX MULT. RSL REGISTERS	
REGISTER	ADDRESS (HEX)
0	1100
1	1101
2	1102
3	1103

TABLE 26. CHANNEL 'B' HALFBAND FILTER RSL REGISTERS	
REGISTER	ADDRESS (HEX)
0	1200
1	1201
2	1202
3	1203

TABLE 27. CHANNEL 'C' HALFBAND FILTER RSL REGISTERS	
REGISTER	ADDRESS (HEX)
0	1300
1	1301
2	1302
3	1303

TABLE 28 HFX COUNT VALUE REGISTERS	
COUNT	ADDRESS (HEX)
0	0C00
1	0D00

TABLE 29. HORIZONTAL BLANKING LEVEL ADDRESS	
CHANNEL	ADDRESS (HEX)
'A'	0207
'B'	0208
'C'	0209
'D'	020A

TABLE 30. MATRIX MULT. & SCALER COEFFICIENT REGISTERS	
REGISTER	ADDRESS (HEX)
0	0000
1	0001
2	0002
3	0003

TABLE 31. LOOK-UP TABLE ADDRESSING	
CHANNEL	ADDRESS (HEX)
'A'	0300
'B'	0400
'C'	0500

High-Definition Video Format Converter

TABLE 32. INPUT BIAS ADDER REGISTER LOADING FORMAT													
	CF12	CF11	CF10	CF9	CF8	CF7	CF6	CF5	CF4	CF3	CF2	CF1	CF0
Address	0	1	0	1	1	0	0	0	0	0	0	0	1
Word 0	0	0	0	0	0	0	1	1	1	1	1	1	1

TABLE 33. OUTPUT BIAS ADDER REGISTER LOADING FORMAT													
	CF12	CF11	CF10	CF9	CF8	CF7	CF6	CF5	CF4	CF3	CF2	CF1	CF0
Address	0	1	0	0	1	0	0	0	0	0	0	1	1
Word 0	0	0	0	0	0	0	0	0	1	0	0	0	0

TABLE 34 MATRIX MULTIPLIER/KEY SCALER COEFFICIENT BANK LOADING FORMAT													
	CF12	CF11	CF10	CF9	CF8	CF7	CF6	CF5	CF4	CF3	CF2	CF1	CF0
Address	0	0	0	0	0	0	0	0	0	0	0	1	0
Coef Bank 0	0	0	0	0	0	0	0	0	0	0	0	0	0
Coef Bank 1	0	0	0	0	0	0	0	0	0	0	0	0	1
Coef Bank 2	0	0	0	0	0	0	0	0	0	0	0	1	0
Coef Bank 3	0	0	0	0	0	0	0	0	0	0	0	1	1
Coef Bank 4	0	0	0	0	0	0	0	0	0	0	1	0	0
Coef Bank 5	0	0	0	0	0	0	0	0	0	0	1	0	1
Coef Bank 6	0	0	0	0	0	0	0	0	0	0	1	1	0
Coef Bank 7	0	0	0	0	0	0	0	0	0	0	1	1	1
Coef Bank 8	0	0	0	0	0	0	0	0	0	1	0	0	0
Coef Bank 9	0	0	0	0	0	0	0	0	0	1	0	0	1

TABLE 35. HFX COUNT VALUE LOADING FORMAT													
	CF12	CF11	CF10	CF9	CF8	CF7	CF6	CF5	CF4	CF3	CF2	CF1	CF0
Address	0	1	1	0	0	0	0	0	0	0	0	0	0
Word 0	R	1	1	0	0	0	0	1	0	0	1	1	1 ^{HF0}
Word 1	R	R	R	R	R	1 ^{HF19}	0	1	1	0	0	1	1

TABLE 36. RSL REGISTER LOADING FORMAT													
	CF12	CF11	CF10	CF9	CF8	CF7	CF6	CF5	CF4	CF3	CF2	CF1	CF0
Address	0	1	1	1	0	0	0	0	0	0	0	0	0
Word 0	R	0	0	0	0	0	0	1	0	0	0	0	0 ^{R0}
Word 1	R	R	R	0 ^{S1}	1	0 ^{S0}	0	0	0	0	0	0	0
Word 2	0 ^{UL12}	1	1	1	1	1	1	1	1	1	1	1	1 ^{UL0}
Word 3	1 ^{LL12}	0	0	0	0	0	0	0	0	0	0	0	1 ^{LL0}

TABLE 37. CONFIGURATION REGISTER LOADING FORMAT													
	CF12	CF11	CF10	CF9	CF8	CF7	CF6	CF5	CF4	CF3	CF2	CF1	CF0
Address	0	0	0	1	0	0	0	0	0	0	0	0	0
Word 0	0	0	0	0	0	1	0	1	0	1	1	1	0

FIGURE 17. CONFIGURATION, INPUT/OUTPUT BIAS ADDER, RSL, AND HBLANK LEVEL REGISTER LOADING SEQUENCE

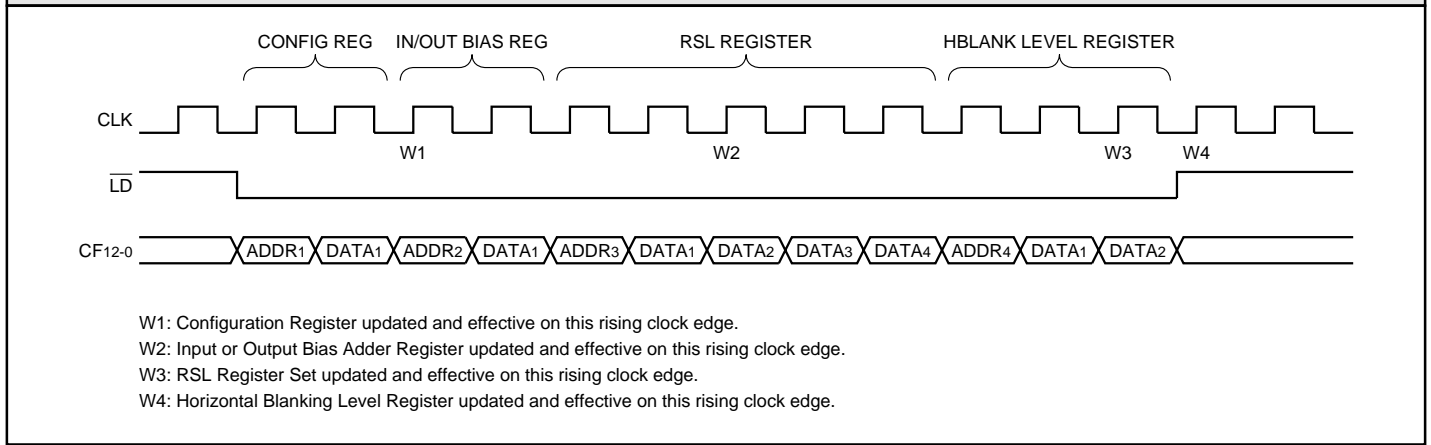

FIGURE 18. LOOK-UP TABLE LOADING SEQUENCE

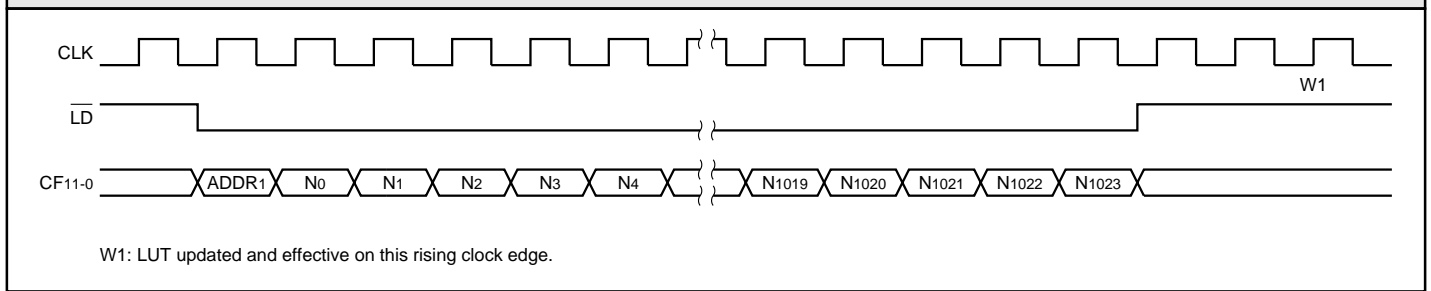

FIGURE 19. MATRIX MULTIPLIER/KEY SCALER COEFFICIENT BANK LOADING SEQUENCE

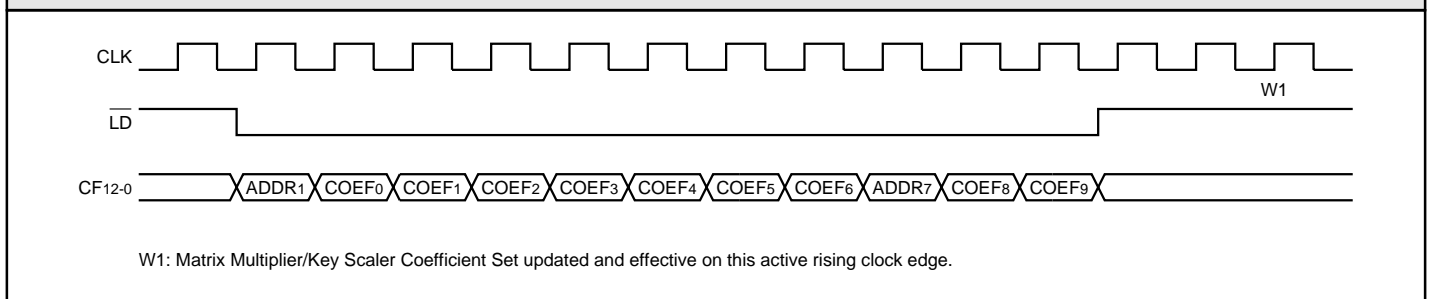
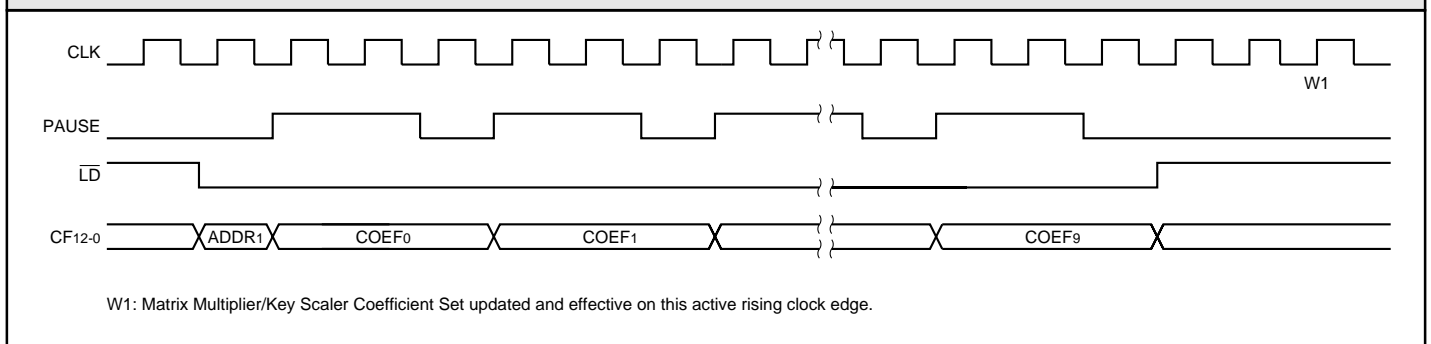

FIGURE 20. MATRIX MULTIPLIER/KEY SCALER COEFFICIENT BANK LOADING SEQUENCE WITH PAUSE IMPLEMENTATION



High-Definition Video Format Converter

MAXIMUM RATINGS *Above which useful life may be impaired (Notes 1, 2, 8)*

Storage temperature	-65°C to +150°C
Operating ambient temperature	0°C to +70°C
V _{CC} supply voltage with respect to ground	-0.5 V to +4.5 V
Input signal with respect to ground	-0.5 V to 5.5 V
Signal applied to high impedance output	-0.5 V to 5.5 V
Output current into low outputs	25 mA
Latchup current	> 400 mA

OPERATING CONDITIONS *To meet specified electrical and switching characteristics*

Mode	Temperature Range (Ambient)	Supply Voltage
Active Operation, Commercial	0°C to +70°C	3.00 V ≤ V _{CC} ≤ 3.60 V

ELECTRICAL CHARACTERISTICS *Over Operating Conditions (Note 4)*

Symbol	Parameter	Test Condition	Min	Typ	Max	Unit
V _{OH}	Output High Voltage	V _{CC} = Min., I _{OH} = -4 mA	2.4			V
V _{OL}	Output Low Voltage	V _{CC} = Min., I _{OL} = 8.0 mA			0.4	V
V _{IH}	Input High Voltage		2.0		5.5	V
V _{IL}	Input Low Voltage		0.0		0.8	V
I _{Ix}	Input Current	Ground ≤ V _{IN} ≤ 5.25 V (Note 12)			±10	μA
I _{OZ}	Output Leakage Current	Ground ≤ V _{OUT} ≤ 5.25 V (Note 12)			±10	μA
I _{CC1}	V _{CC} Current, Dynamic	At Max Operating Frequency			100	mA
C _{IN}	Input Capacitance	T _A = 25°C, f = 1 MHz			10	pF
C _{OUT}	Output Capacitance	T _A = 25°C, f = 1 MHz			10	pF

SWITCHING CHARACTERISTICS			
COMMERCIAL OPERATING RANGE (0°C to +70°C) Notes 9, 10 (ns)			
Symbol	Parameter	LF3370-	
		12	
		Min	Max
t _{CYC}	Cycle Time	12	
t _{PWL}	Clock Pulse Width Low	5	
t _{PWH}	Clock Pulse Width High	5	
t _S	Input Setup Time	4	
t _H	Input Hold Time	0	
t _{SCT}	Setup Time Control Inputs	4	
t _{HCT}	Hold Time Control Inputs	0	
t _D	Output Delay		8
t _{DIS}	Three-State Output Disable Delay (Note 11)		10
t _{ENA}	Three-State Output Enable Delay (Note 11)		10

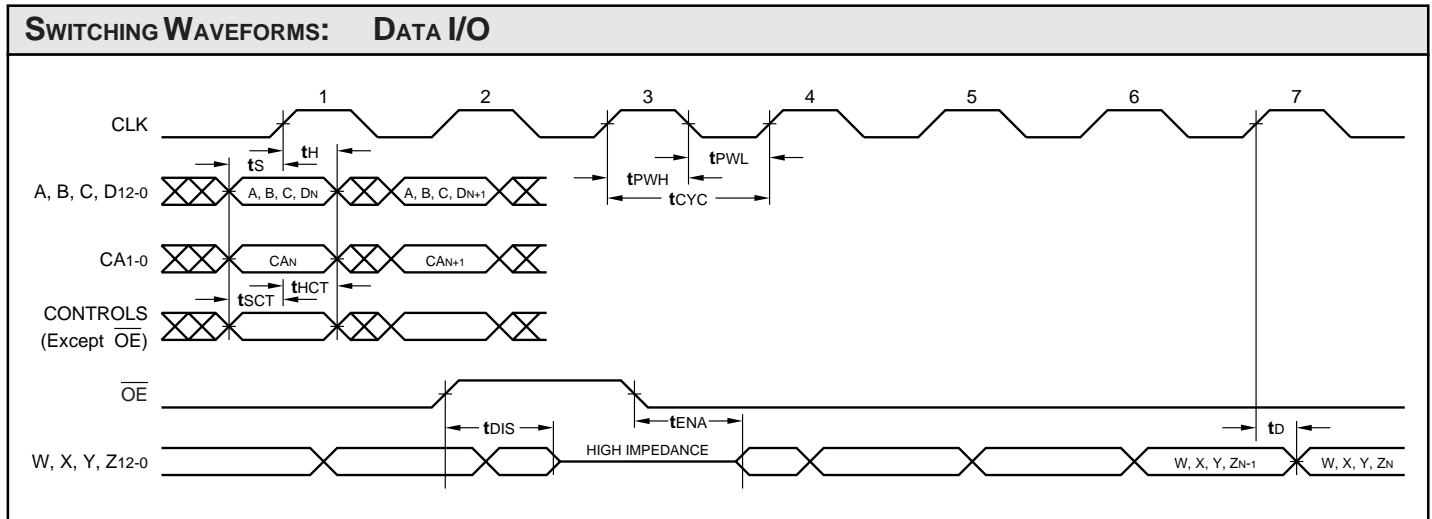

High-Definition Video Format Converter

COMMERCIAL OPERATING RANGE (0°C to +70°C) Notes 9, 10 (ns)			
		LF3370-	
		12	
Symbol	Parameter	Min	Max
tCFS	Configuration Input Setup	5.5	
tCFH	Configuration Input Hold	0	
tLS	Load Setup Time	4	
tLH	Load Hold Time	0	
tPS	PAUSE Setup Time	4	
tPH	PAUSE Hold Time	0	

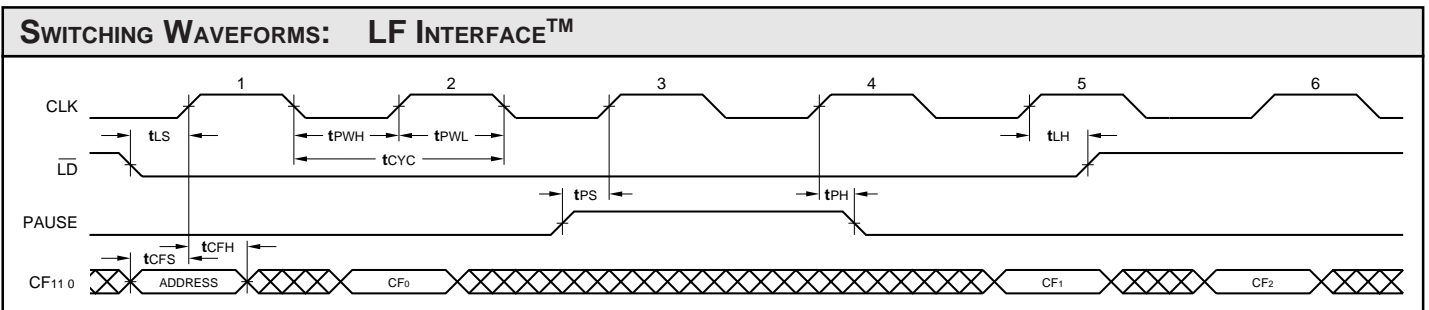

ORDERING INFORMATION

160-pin

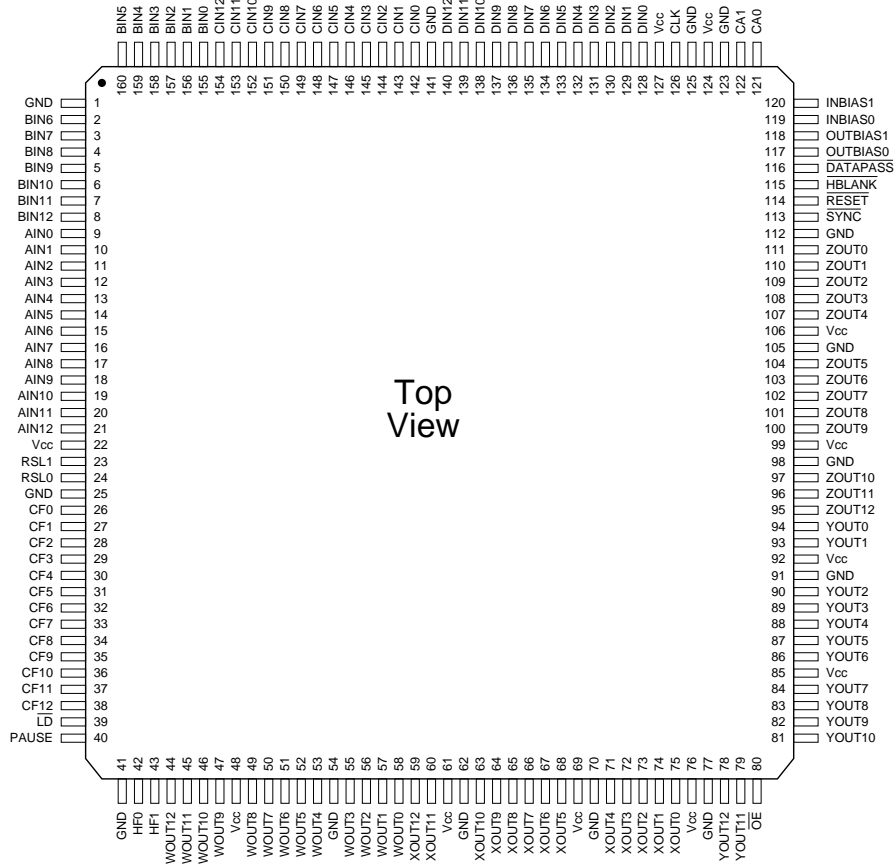

Top View

Speed	Plastic Quad Flatpack (Q6)
	0°C to +70°C — COMMERCIAL SCREENING
12 ns	LF3370QC12

Contact factory for additional information.



DEVICES INCORPORATED

1320 Orleans Drive
Sunnyvale, CA 94089

tel. 800.851.0767

408.542.5400

fax. 408.542.0080

www.logicdevices.com

apps@logicdevices.com

applications hotline 408.542.5446 (08:00 17:00 Pacific)