

DUAL AUTO-ZEROED OPERATIONAL AMPLIFIERS

FEATURES

- **First Monolithic Dual Auto-Zeroed Operational Amplifier**
- **Chopper Amplifier Performance Without External Capacitors**
 - V_{OS} **15 μ V Max**
 - V_{OS} Drift **0.15 μ V/ $^{\circ}$ C Max**
 - **Saves Cost/Assembly of Four "Chopper" Capacitors**
- **SOIC Packages Available**
- **High DC Gain** **120dB**
- **Low Supply Current** **650 μ A**
- **Low Input Voltage Noise**
(0.1 Hz to 10 Hz) **0.65 μ V_{P-P}**
- **Wide Common-Mode**
Voltage Range **V_{SS} to $V_{DD} - 2V$**
- **High Common-Mode Rejection** **116dB**
- **Dual or Single Supply Operation** **$\pm 3.3V$ to $\pm 8.3V$**
+6.5V to +16V
- **Excellent AC Operating Characteristics**
 - Slew Rate **2.5V/ μ sec**
 - Unity-Gain Bandwidth **1.5MHz**
- **Pin Compatible With LM358, OP-14, MC1458, ICL7621, TL082, TLC322**

ORDERING INFORMATION

Part No.	Package	Temp. Range	Maximum Offset Voltage
TC913ACOA	8-Pin SOIC	0 $^{\circ}$ C to +70 $^{\circ}$ C	15 μ V
TC913ACPA	8-Pin Plastic DIP	0 $^{\circ}$ C to +70 $^{\circ}$ C	15 μ V
TC913BCOA	8-Pin SOIC	0 $^{\circ}$ C to +70 $^{\circ}$ C	30 μ V
TC913BCPA	8-Pin Plastic DIP	0 $^{\circ}$ C to +70 $^{\circ}$ C	30 μ V

PIN CONFIGURATION (SOIC and DIP)

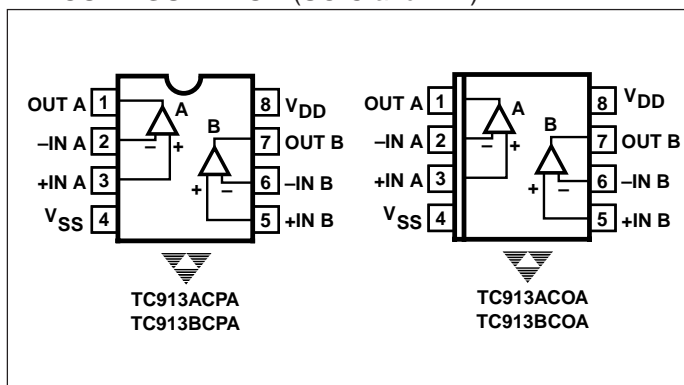

GENERAL DESCRIPTION

The TC913 is the world's first complete monolithic, dual auto-zeroed operational amplifier. The TC913 sets a new standard for low-power, precision dual-operational amplifiers. Chopper-stabilized or auto-zeroed amplifiers offer low offset voltage errors by periodically sampling offset error, and storing correction voltages on capacitors. Previous single amplifier designs required two user-supplied, external 0.1 μ F error storage correction capacitors — much too large for on-chip integration. The unique TC913 architecture requires smaller capacitors, making on-chip integration possible. Microvolt offset levels are achieved and **external capacitors are not required**.

The TC913 system benefits are apparent when contrasted with a TC7650 chopper amplifier circuit implementation. A single TC913 replaces two TC7650's and four capacitors. Five components and assembly steps are eliminated.

The TC913 pinout matches many popular dual-operational amplifiers: OP-04, TLC322, LM358, and ICL7621 are typical examples. In many applications, operating from dual 5V power supplies or single supplies, the TC913 offers superior electrical performance, and can be a functional drop-in replacement; printed circuit board rework is not necessary. The TC913's low offset voltage error eliminates offset voltage trim potentiometers often needed with bipolar and low-accuracy CMOS operational amplifiers.

The TC913 takes full advantage of TelCom's proprietary CMOS technology. Unity gain bandwidth is 1.5 MHz and slew rate is 2.5 V/ μ sec.

FUNCTIONAL BLOCK DIAGRAM

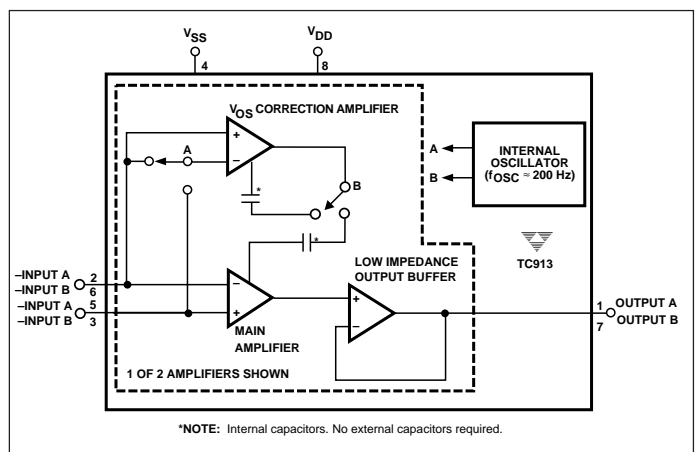

DUAL AUTO-ZEROED OPERATIONAL AMPLIFIERS

TC913A TC913B

ABSOLUTE MAXIMUM RATINGS*

Total Supply Voltage (V_{DD} to V_{SS})	+18V
Input Voltage ($V_{DD} + 0.3V$) to ($V_{SS} - 0.3V$)	
Current into Any Pin	10mA
While Operating	100 μ A
Storage Temperature Range	-65°C to +150°C
Lead Temperature (Soldering, 10 sec)	+300°C
Operating Temperature Range	
C Device	0°C to +70°C

Package Power Dissipation ($T_A \leq 70^\circ\text{C}$)

Plastic SOIC	470mW
Plastic DIP	730mW

*Static-sensitive device. Unused devices should be stored in conductive material. Stresses above those listed under "Absolute Maximum Ratings" may cause permanent damage to the device. These are stress ratings only and functional operation of the device at these or any other conditions above those indicated in the operational sections of the specifications is not implied.

ELECTRICAL CHARACTERISTICS: $V_S = \pm 5V$, $T_A = +25^\circ\text{C}$, unless otherwise indicated.

Symbol	Parameter	Test Conditions	TC913A			TC913B			Unit
			Min	Typ	Max	Min	Typ	Max	
V_{OS}	Input Offset Voltage	$T_A = +25^\circ\text{C}$	—	5	15	—	15	30	μV
TCV_{OS}	Average Temperature Coefficient of Input Offset Voltage	$0^\circ\text{C} \leq T_A \leq +70^\circ\text{C}$	—	0.05	0.15	—	0.1	0.25	$\mu\text{V}/^\circ\text{C}$
		$-25^\circ\text{C} \leq T_A \leq +85^\circ\text{C}$ (Note 1)	—	0.05	0.15	—	0.1	0.25	$\mu\text{V}/^\circ\text{C}$
I_B	Average Input Bias Current	$T_A = +25^\circ\text{C}$	—	—	90	—	—	120	μA
		$0^\circ\text{C} \leq T_A \leq +70^\circ\text{C}$	—	—	3	—	—	4	nA
		$-25^\circ\text{C} \leq T_A \leq +85^\circ\text{C}$	—	—	4	—	—	6	nA
I_{OS}	Average Input Offset Current	$T_A = +25^\circ\text{C}$	—	5	20	—	10	40	μA
		$T_A = +85^\circ\text{C}$	—	—	1	—	—	1	nA
e_N	Input Voltage Noise	0.1 to 1 Hz, $R_S \leq 100\Omega$	—	0.6	—	—	0.6	—	μV_{P-P}
		0.1 to 10 Hz, $R_S \leq 100\Omega$	—	11	—	—	11	—	μV_{P-P}
CMRR	Common-Mode Rejection Ratio	$V_{SS} \leq V_{CM} \leq V_{DD} - 2.2V$	110	116	—	100	110	—	dB
CMVR	Common-Mode Voltage Range		V_{SS}	—	$V_{DD} - 2$	V_{SS}	—	$V_{DD} - 2$	V
A_{OL}	Open-Loop Voltage Gain	$R_L = 10\text{ k}\Omega$, $V_O = \pm 4V$	115	120	—	110	120	—	dB
V_{OUT}	Output Voltage Swing	$R_L = 10\text{ k}\Omega$	$V_{SS} + 0.3$	—	$V_{DD} - 0.9$	$V_{SS} + 0.3$	—	$V_{DD} - 0.9$	V
BW	Closed-Loop Bandwidth	Closed Loop Gain = +1	—	1.5	—	—	1.5	—	MHz
SR	Slew Rate	$R_L = 10\text{ k}\Omega$, $C_L = 50\text{ pF}$	—	2.5	—	—	2.5	—	V/ μs
PSRR	Power Supply Rejection Ratio	$\pm 3.3V \leq V_S \leq \pm 5.5V$	110	—	—	100	—	—	dB
V_S	Operating Supply Voltage Range	Split Supply	± 3.3	—	± 8.3	± 3.3	—	± 8.3	V
		Single Supply	6.5	—	16	6.5	—	16	V
I_S	Quiescent Supply Current	$V_S = \pm 5V$	—	0.65	0.85	—	—	1.1	mA

NOTE: 1. Characterized; not 100% tested.

Theory of Operation

Each of the TC913's two op-amps actually consists of two amplifiers. A main amplifier is always connected from the input to the output. A separate nulling amplifier alternately nulls its own offset and then the offset of the amplifier. Since each amplifier is continuously being nulled, offset voltage drift with time, temperature, and power supply variations is greatly reduced.

All nulling circuitry is internal and the nulling operation is transparent to the user. Offset nulling voltages are stored on two internal capacitors. An internal oscillator and control logic, shared by the TC913's two amplifiers, control the nulling process.

Pin Compatibility

The TC913 pinout is compatible with OP-14, LM358, MC1458, LT1013, TLC322, and similar dual op amps. In many circuits operating from single or $\pm 5V$ supplies, the TC913 is a drop-in replacement offering DC performance rivaling that of the best single op amps.

The TC913's amplifiers include a low-impedance class AB output buffer. Some previous CMOS chopper amplifiers used a high-impedance output stage which made open-loop gain dependent on load resistance. The TC913's open-loop gain is not dependent on load resistance.

Overload Recovery

The TC913 recovers quickly from output saturation. Typical recovery time from positive output saturation is 20msec. Negative output saturation recovery time is typically 5msec.

Avoiding Latch-Up

Junction-isolated CMOS circuits inherently contain a parasitic p-n-p-n transistor circuit. Voltages exceeding the supplies by 0.3V should not be applied to the device pins. Larger voltages can turn the p-n-p-n device on, causing excessive device power supply current and power dissipation. The TC913's power supplies should be established at the same time or before input signals are applied. If this is not possible, input current should be limited to 0.1mA to avoid triggering the p-n-p-n structure.

DUAL AUTO-ZEROED OPERATIONAL AMPLIFIERS

TC913A
TC913B

TYPICAL CHARACTERISTICS

