

# Power Transistor (120V, 1.5A)

## 2SC4132 / 2SD1857

### ●Features

- 1) High breakdown voltage. ( $BV_{CEO} = 120V$ )
- 2) Low collector output capacitance.  
(Typ. 20pF at  $V_{CB} = 10V$ )
- 3) High transition frequency. ( $f_T = 80MHz$ )
- 4) Complements the 2SB1236.

### ●Absolute maximum ratings ( $T_a = 25^\circ C$ )

Parameter	Symbol	Limits	Unit
Collector-base voltage	$V_{CBO}$	120	V
Collector-emitter voltage	$V_{CEO}$	120	V
Emitter-base voltage	$V_{EBO}$	5	V
Collector current	$I_C$	2	A
	$I_{CP}$	3	A <sup>*1</sup>
Collector power dissipation	$P_C$	0.5	W <sup>*2</sup>
		2	
		1	
Junction temperature	$T_J$	150	$^\circ C$
Storage temperature	$T_{stg}$	-55~+150	$^\circ C$

\*1 Single pulse  $P_w = 10ms$

\*2 When mounted on a  $40 \times 40 \times 0.7mm$  ceramic board.

### ●Packaging specifications and $h_{FE}$

Type	2SC4132	2SD1857
Package	MPT3	ATV
$h_{FE}$	PQR	PQR
Marking	CB*	-
Code	T100	TV2
Basic ordering unit (pieces)	1000	2500

\* Denotes  $h_{FE}$

### ●Electrical characteristics ( $T_a = 25^\circ C$ )

Parameter	Symbol	Min.	Typ.	Max.	Unit	Conditions
Collector-base breakdown voltage	$BV_{CBO}$	120	-	-	V	$I_C = 50\mu A$
Collector-emitter breakdown voltage	$BV_{CEO}$	120	-	-	V	$I_C = 1mA$
Emitter-base breakdown voltage	$BV_{EBO}$	5	-	-	V	$I_E = 50\mu A$
Collector cutoff current	$I_{CBO}$	-	-	1	$\mu A$	$V_{CB} = 100V$
Emitter cutoff current	$I_{EBO}$	-	-	1	$\mu A$	$V_{EB} = 4V$
Collector-emitter saturation voltage	$V_{CE(sat)}$	-	-	0.4	V	$I_C/I_B = 1A/0.1A$ *
DC current transfer ratio	$h_{FE}$	82	-	390	-	$V_{CE}/I_C = 5V/0.1A$
Transition frequency	$f_T$	-	80	-	MHz	$V_{CE} = 5V, I_E = -0.1A, f = 30MHz$
Output capacitance	$C_{ob}$	-	20	-	pF	$V_{CB} = 10V, I_E = 0A, f = 1MHz$ *

\* Measured using pulse current.

### ●External dimensions (Units : mm)

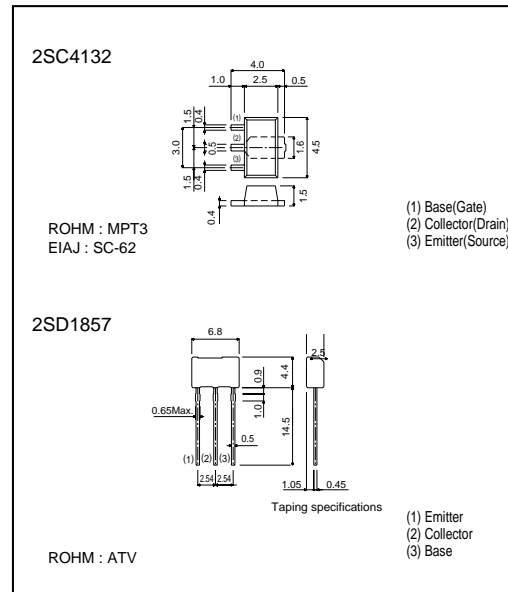

This datasheet has been download from:

[www.datasheetcatalog.com](http://www.datasheetcatalog.com)

Datasheets for electronics components.