

GM6535

60 MHz Universal Programmable Dual PLL Frequency synthesizer

GENERAL DESCRIPTIONS

The GM6535 is a dual phase – locked loop (PLL) frequency synthesizer especially designed for CT-1 cordless phone applications worldwide. This frequency synthesizer is also for any products with frequency operation at 60 MHz or below.

The device features fully programmable receive, transmit, reference, and auxiliary reference counters accessed through an MCU serial interface, this feature allows this device to operate in any CT-1 cordless phone application.

The device consists of two independent phase detectors for transmit and receive loops. A common reference oscillator, driving two independent reference frequency counters, provides independent reference frequencies for transmit and receive loops.

The auxiliary reference counter allows the user to select an additional reference frequency for receive and transmit loops if required.

PIN CONFIGURATION

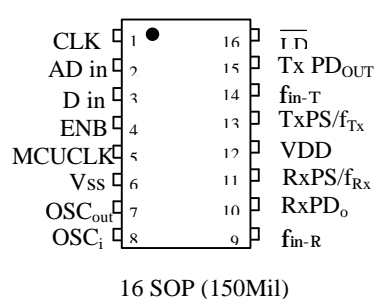
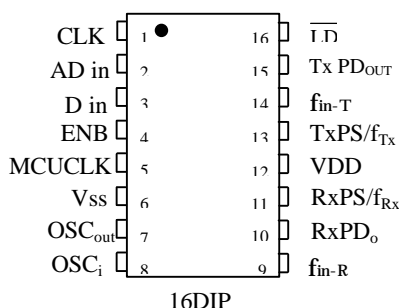

ABSOLUTE MAXIMUM RATINGS (Voltages Referenced to v_{SS})

Symbol	Rating	Value	Unit
V_{DD}	DC Supply Voltage	-0.5 to +6.0	V
V_{in}	Input Voltage, all Inputs	-0.5 to $V_{DD}+0.5$	V
I_{in}, I_{out}	DC Current Drain Per Pin	10	mA
I_{DD}, I_{SS}	DC Current Drain V_{DD} or V_{SS} Pins	30	mA
T_{stg}	Storage Temperature Range	-65 to + 150	$^{\circ}C$

FEATURES

- Operating Voltage Range: 2.5 to 5.5 V
- Operating Temperature Range: -40 to +75 $^{\circ}C$
- Operating Power Consumption: 3.0mA @ 2.5V
- Maximum Operating Frequency: 60MHz @ 200mV_{p-p}, $V_{DD}=2.5V$
- 3 or 4 Pins Used for serial MCU Interface
- Power Saving Mode Controlled by MCU
- Lock Detect Signal
- On-Chip Reference Oscillator Supports External Crystals to 16.0 MHz
- Reference Frequency Counter Division Range: 16 to 4095
- Auxiliary Reference Frequency Counter Division Range: 16 to 16,383
- Transmit Counter Division Range: 16 to 65,535
- Receive Counter Division Range: 16 to 65,535

BLOCK DIAGRAM

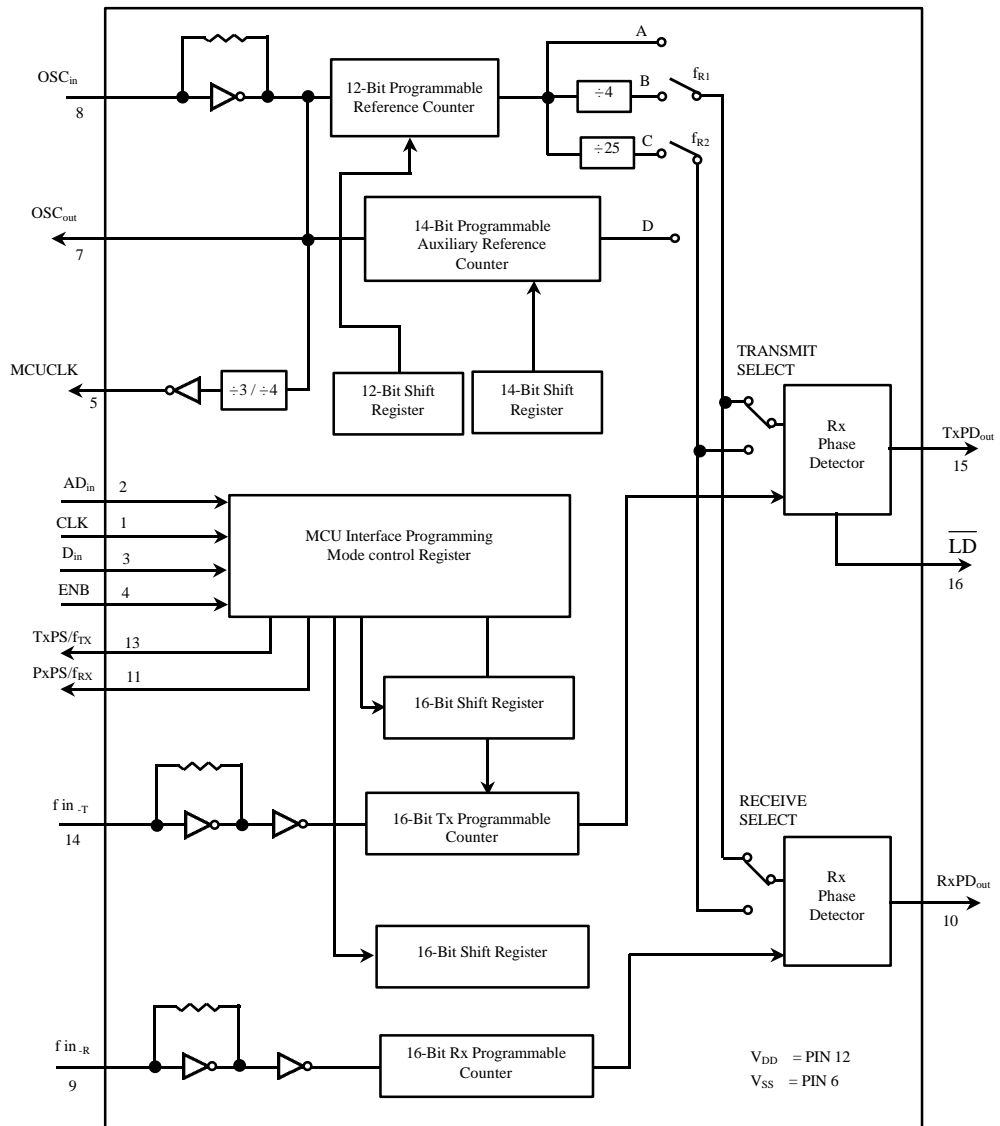

ELECTRICAL CHARACTERISTICS (Voltages Referenced to V_{SS} , $T_A=25$ °C)

Symbol	Characteristic	V_{DD}	Guaranteed Limit		Unit	
			Min	Max		
V_{DD}	Power Supply Voltage	-	2.5	5.5		
V_{OL}	Output Voltage ($I_{out} = 0$)	0 Level	2.5	-	0.1	V
			5.5	-	0.1	
V_{OH}	(V _{in} =V _{DD} or 0)	1 Level	2.5	2.45	-	V
			5.5	5.45	-	
V_{IL}	Input Voltage (V _{out} 0.5 V or V _{DD} - 0.5V)	0 Level	2.5	-	0.75	V
			5.5	-	1.65	
V_{IH}		1 Level	2.5	1.75	-	
			5.5	3.85	-	
V_{OH}	Output Current (V _{out} = 2.2V) (V _{out} = 5.0V)	Source	2.5	-0.18	-	mA
			5.5	-0.55	-	
I_{OL}	(V _{out} = 0.3V) (V _{out} = 0.5V)	Sink	2.5	0.18	-	
			5.5	0.55	-	
I_{IL}	Input Current (V _{in} = 0)	OSC _{in} , f _{in-T} , f _{in-R}	2.5	-	-30	µA
			5.5	-	-66	
		AD _{in} , CLK, D _{in} , ENB	2.5	-	-1.0	
			5.5	-	-1.0	
I_{IH}	(V _{in} = V _{DD} - 0.5)	OSC _{in} , f _{in-T} , f _{in-R}	2.5	-	30	µA
			5.5	-	61	
		AD _{in} , CLK, D _{in} , ENB	2.5	-	5.0	
			5.5	-	5.0	
I_{OZ}	Three-Stats Leakage Current (V _{out} = 0 V or 5.5 V)	5.5	-	100	nA	
C_{in}	Input Capacitance	-	-	8.0	pF	
C_{out}	Output Capacitance	-	-	8.0	pF	
I_{DD} (standby)	Standby Current (All Counters are in Power-Down Mode with Oscillator On)	2.5	-	0.3	mA	
		5.5	-	1.5		
I_{DD}	Operating Current (200mV _{p-p} input at f _{in-T} = 60MHz, and f _{in-R} = 60MHz, OSC = 10.24MHz)	2.5	-	3.0	mA	
		5.5	-	10		

SWITCHING CHARACTERISTICS ($T_A = 25^\circ\text{C}$; $C_L = 50\text{ pF}$)

Symbol	Characteristic	Figure #	V_{DD}	Min	Max	Unit
t_{TLH}	Output Rise Time	1	2.5 5.5	- -	200 100	ns
t_{THL}	Output Fall Time	1	2.5 5.5	- -	200 100	ns
t_r, t_f	Input Rise and Fall Time, OSC_{in}	2	2.5 5.5	- -	5.0 4.0	μs
t_w	Input Pulse Width, CLK and ENB	3	2.5 5.5	80 60	- -	ns
f_{max}	Input frequency (Input = Sine Wave @ $\geq 200\text{mV}_{p-p}$)	OSC_{in} f_{in-T} f_{in-R}	2.5-5.5 2.5-5.5 2.5-5.5	- - -	16 60 60	MHz
t_{su}	Setup Time Data to CLK ENB to CLK	5	2.5-5.5 5.5-5.5	100 200	- -	ns
t_h	Hold Time, CLK to Data	5	2.5 5.5	80 40	- -	ns
t_{rec}	Recovery Time, ENB to CLK	5	2.5 5.5	80 40	- -	ns
t_{sul}	Setup Time, ENB to CLK	4	2.5-5.5	80	-	ns
t_{hl}	Hold Time, CLK to ENB	4	2.5-5.5	600	-	ns

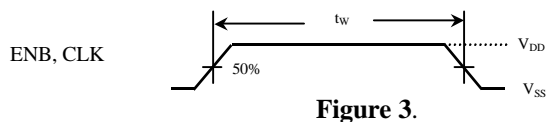
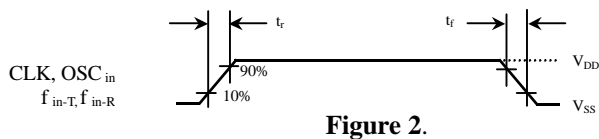
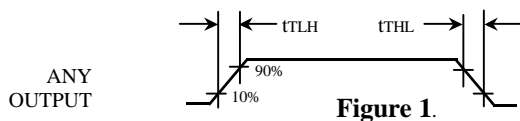
SWITCHING WAVEFORMS

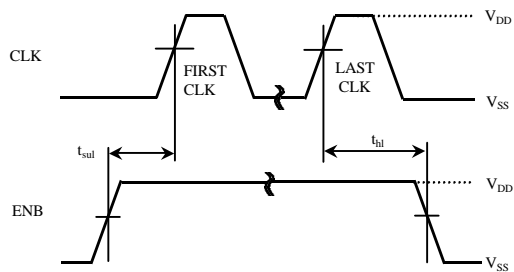

Figure 4. ENB High During Serial Transfer

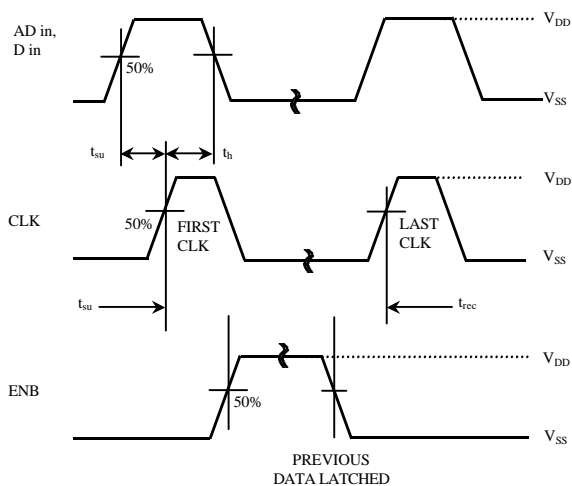

Figure 5. ENB Low During Serial Transfer

PIN DESCRIPTIONS

OSC_{in}/OSC_{out}

Reference Oscillator Input/Output (Pins8, 7)

These pins form a reference oscillator when connected to an external parallel-resonant crystal frequencies and reference frequencies for cordless phone applications in various countries. OSC_{in} may also serve as input for an externally generated reference signal which is typically ac coupled.

AD_{in}, D_{in}, CLK, ENB

Auxiliary Data In, Data In, Clock, Enable (Pins2, 3, 1, 4)

These four pins provide an MCU serial interface for programming the reference counter, the transmit-channel counter, and the receive-channel counter. They also provide various controls of the PLL including the power saving mode and the programming format.

TxPS/f_{Tx}, RxPS/f_{Rx}

Transmit Power Save, Receive Power Save (Pins 13, 11)

For a normal application, these output pins provide the status of the internal power saving mode operation. If the transmit channels counter circuitry is in power down mode, TxPS/f_{Tx} outputs a high state. If the receive-channels counter circuitry is in power down mode, RxPS/f_{Rx} is set high. These output can be applied for controlling the external power switch for the transmitter and the receiver to save MCU control pins. In the Tx/Rx channel counter test mode, the TxPS/f_{Tx} and RxPS/f_{Rx} pins output the divided value of the transmit channel counter (f_{Tx}) and the receive channel counter (f_{Rx}), respectively. This test mode operation is controlled by the control register. Details of the counter test mode are in the Tx/Rx Channel Counter Test section of this data sheet.

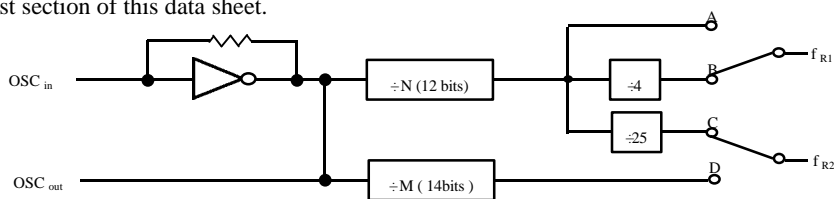

Crystal	$\div N$ Value	f_{R1} $\div 4$	f_{R2} $\div 25$
11.150 MHz	446	6.25 MHz	1.0 MHz
11.150 MHz	223	12.5 MHz	
10.240 MHz	512	5.0 MHz	
12.000 MHz	600	5.0 MHz	

Figure 6. Reference Frequencies for Cordless Phone Applications of Various Countries

f_{in-T}/f_{in-R}

Transmit/Receive Counter Inputs (Pins14, 9)

f_{in-T} and f_{in-R} are inputs to the transmit and the receive counters, respectively. These signals are typically driven from the loop VCO and ac-coupled. The minimum input signal level is 200mV_{p-p} @ 60.0MHz.

TxPD_{out}/RxPD_{out}

Transmit/Receive Phase detector Outputs (Pins15, 10)

These are three-state outputs of the transmit and receive phase detectors for use as loop error signals (see Figure7 for phase detector output waveforms).

Frequency $f_v > f_R$ or f_v leading: output=negative pulse.
 Frequency $f_v < f_R$ or f_v lagging: output = positive pulse.
 Frequency $f_v = f_R$ and phase coincidence: output = high impedance state.

f_R is the divided-down reference frequency at the phase detector input and f_v is the divided-down VCO frequency at the phase detector input.

LD Lock Detect (Pin16)

The lock detect signal is associated with the transmit loop. The output at a high level indicates an out-of-lock condition (see Figure 7 for the LD output waveform).

V_{DD} Positive Power Supply (Pin 12)

V_{DD} is the most positive power supply potential ranging from 2.5 to 5.5V with respect to VSS.

V_{SS} Negative Power Supply (Pin 6)

V_{SS} is the most negative supply potential and is usually connected to ground.

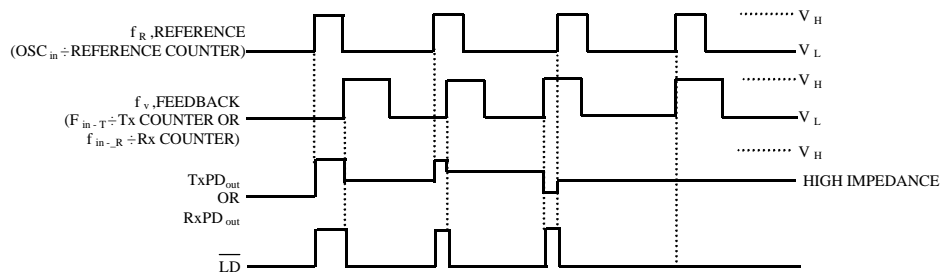

V_H = High voltage level

V_L = Low voltage level

*At this point, when both f_R and f_v are in phase, the output is forced to near mid supply.

NOTE: The TxPD_{out} and RxPD_{out} generates error pulses during out-of-lock conditions.

When locked in phase and frequency, the output is high impedance and the voltage at that pin is determined by the low-pass filter capacitor

Figure 7. Phase Detector/Lock Detector Output Waveforms

MCU PROGRAMMING SCHEME

The MCU programming scheme is defined in two formats controlled by the ENB input. If the enable signal is high during the serial data transfer, control register/reference frequency programming is selected. If the ENB is low, programming of the transmit and receive counters is selected. During programming of the transmit and receive counters, both AD_{in} and D_{in} pins can input the data to the transmit and receive counters. Both counters data is clocked into the PLL internal shift register at the leading edge of the CLK signal. It is not necessary to reprogram the reference frequency counter/control register when using the enable signal to program the transmit/receive channels.

In programming the control register/reference frequency scheme, the most significant bit (MSB) of the programming word identifies whether the input data is the control word. If the MSB is 1, the input data is the control word (Figure 8). Also see figure NO TAG and Table 1 for control register and bit function. If the MSB is 0, the input data is the reference frequency (Figure 9).

The reference frequency data word is 32-bit word containing the 12-bit reference frequency data, the 14-bit auxiliary reference frequency counter information, the reference frequency selection plus, the auxiliary reference frequency counter enable bit(Figure 9).

If the AUX REF ENB bit is high, the 14-bit auxiliary reference frequency counter provides an additional phase reference frequency output for the

loops. If AUX REF ENB bit is low, the auxiliary reference frequency counter is forced into power-down modes for current saving. (other power down modes are also provided through the control register per Table 2 and Figure 8). At the falling edge of the ENB signal, the data is stored in the registers.

There are two interfacing schemes for the universal channel mode: the three-pin and four-pin interfacing schemes. The three-pin interfacing scheme is suited for use with the MCU SPI (serial peripheral interface) (Figure 10), while the four-pin interfacing scheme is commonly used for general I/O port connection (Figure 11).

For the three-pin interfacing scheme, the auxiliary data select bit is set to 0. All 32 bits of data, which define both the 16-bit transmit counter and the 16-bit receive counter, latch into the PLL internal register though the data in pins at the leading edge of CLK. See Figure 12 and 13.

For the four-pin interfacing scheme, the auxiliary data select bit is set to 1. In this scheme, the 16-bit transmit counter's data enters into the AD_{in} pin at the same time as the 16-bit receive. This simultaneous entry of the transmit and receive counters causes the programming period of the four-pin scheme to be half that of the three-pin scheme (see Figures 14 and 15).

While programming Tx/Rx Channel Counter, the ENB pin must be pulsed to provide falling edge to latch the shifted data after the rising edge of the last clock. Maximum data transfer rate is 500 kbps.

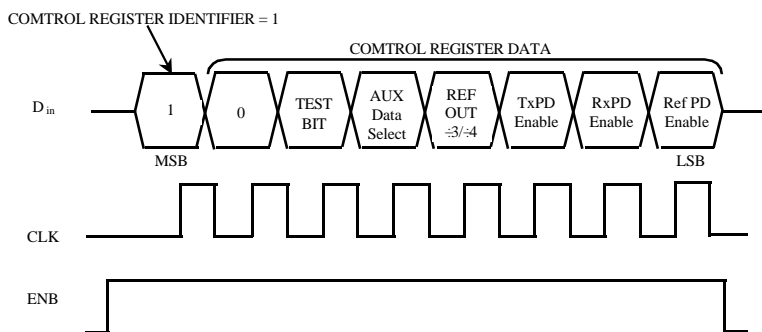

Figure 8. Programming Format of the control Register

Table 1. Control Register Function Bits Description

Test Bit	Set to 1 for Tx/Rx channel counter test mode Set to 0 for normal application
Aux Data Select	Set to 1 for both AD _{in} and D _{in} pins inputting the transmit 16-bits data and receive 16-bits data respectively Set to 0 for normal application interfacing with MCU serial peripheral interface. Does not use AD _{in} pin; tie AD _{in} to V _{SS} .
REF _{out} ÷3/÷4	If set to 1, REF _{out} output frequency is equal to OSC _{out} ÷ 3. If set to 0, REF _{out} output is OSC _{out} ÷ 4.
TxPD Enable	If set to 1, the transmit counter, transmit phase detector, and the associated circuitry is in power-down mode. TxPS/f _{Tx} is set "High".
RxPD Enable	If set to 1, the receive counter, receive phase detector, and the associated circuitry is in power-down mode. RxPS/f _{Tx} is set "High".
Ref PD Enable	If set to 1, both 12-bit and 14-bit reference frequency counters are in power-down mode

Table 2. Control Register Power Down Bits Function

TxPD Enable	RxPD Enable	REF PD Enable	Tx-Channel Counter	Rx-channel Counter	Reference Frequency Counter
0	0	0	-	-	-
0	0	1	-	-	Power Down
0	1	0	-	Power Down	-
0	1	1	-	Power Down	Power Down
1	0	0	Power Down	-	-
1	0	1	Power Down	-	Power Down
1	1	0	Power Down	Power Down	-
1	1	1	Power Down	Power Down	Power Down

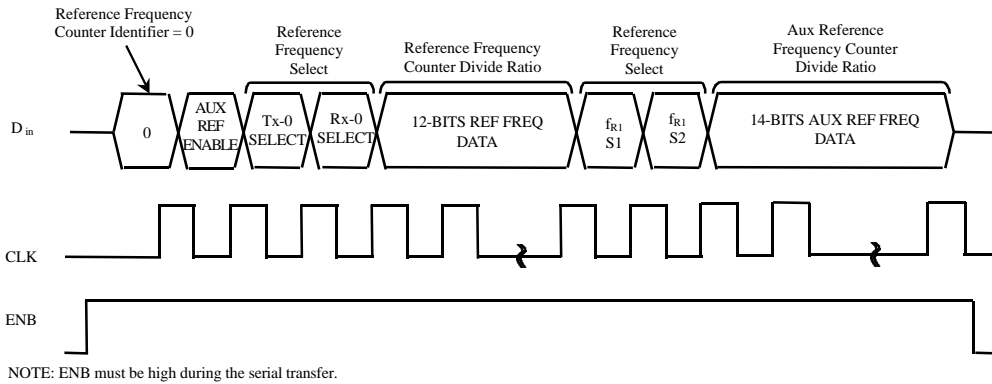

Figure 9. Programming Format of Auxiliary/reference Frequency Counter

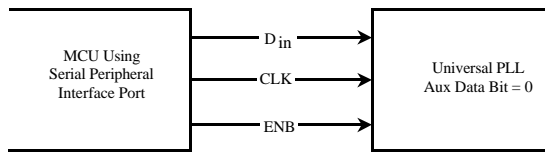

Figure 10. MCU Interface Using SPI

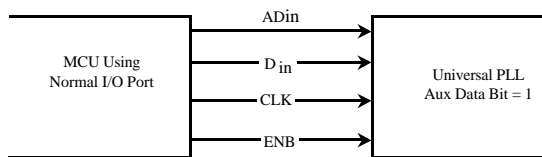

Figure 11. MCU Interface Using Normal I/O Ports with Both D_{in} And A D_{in} for Faster Programming Time

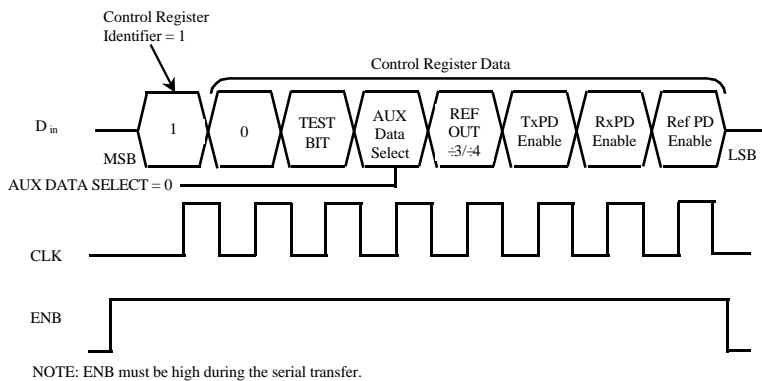
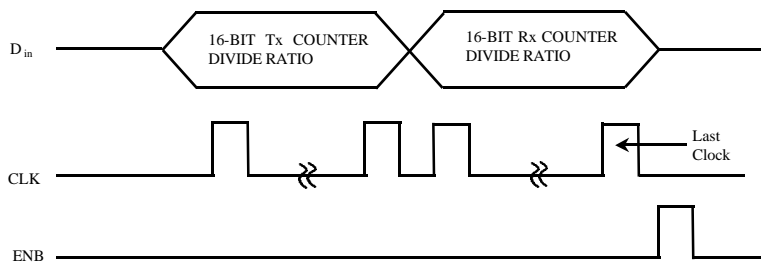
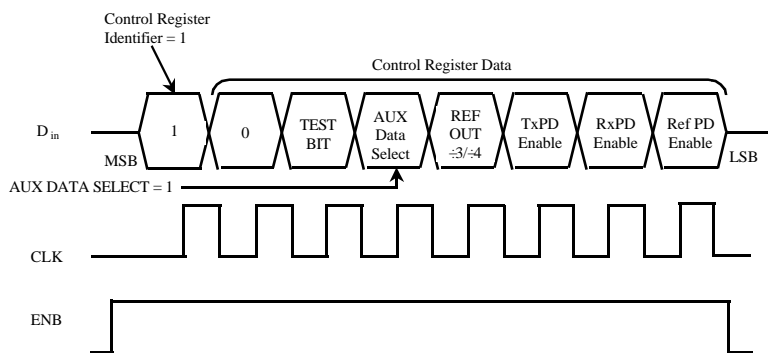

Figure 12. Programming Format for control register (3-Pin Interfacing Scheme)



NOTE: ENB must be low during the serial transfer.

Figure 13. Programming Format for Transmit and Receive Counters (3-Pin Interfacing Scheme)



NOTE: ENB must be high during the serial transfer.

Figure 14. Programming Format for control Register (4-Pin Interfacing Scheme)

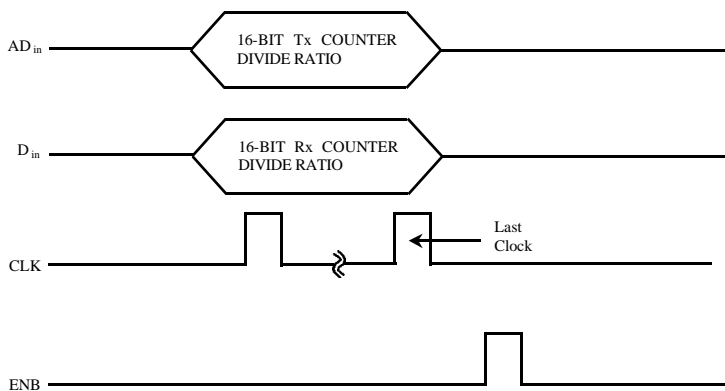

NOTE: ENB must be low during the serial transfer.

Figure 15. Programming Format for Transmit and Receive Counters (4-Pin Interfacing Scheme)

Table 3. Global CT-1 Reference frequency Setting vs Channel Frequencies

Country	Channel Frequency	f_{R1}	f_{R2}
U.S.A	46/49MHz(10,15,25 Channels)	5.0 KHz	-
France	26/41 MHz	6.25 KHz/12.5 KHz	-
Spain	31/41 MHz	5.0 KHz	-
Australia	30/39 MHz	5.0 KHz	-
U.K	1.7/47 MHz	6.25 KHz	1.0 KHz
New Zealand	1.7/34/40 MHz	6.25 KHz	1.0 KHz

REFERENCE FREQUENCY SELECTION AND PROGRAMMING

Figure 16 shows the bit function of the reference frequency programming word. The user can either select the fixed reference frequency for all channels accordingly or provide a specific reference frequency for a particular channel by using two reference frequency counters (e.g., for an application in France, the base set transmit channel common fixed reference frequency is 6.25 KHz or 12.5 KHz). (See Table 3 Figure 6 for reference frequencies for various countries.)

However, transmit channels 6, 8, and 14 can be set to 25 KHz, and channel 8 reference frequency can be set to 50 KHz. But this reference frequency may not be applied to the receiving side; therefore, the receiving side reference frequency must be generated by another reference frequency counter. The higher the reference frequency, the better the phase noise performance and faster the lock time, but the PLL consumes more current if both reference frequency counters are in operation. In general, the 12-bit reference frequency counter plus the $\div 4$ and $\div 25$ module can offer all the reference

frequencies for global CT-1 transmit and receive channel requirements. Users can select their own reference frequency by introducing the additional 14-bit auxiliary reference frequency counter.

Again, the 14-bit auxiliary reference frequency counter can be shut down by the auxiliary reference enable bit in the reference counter programming word by setting the bit to 0. At this state, the f_{R2} is automatically connected to point C (the $\div 25$ block output), and f_{R1} can be connected to point A or B by setting the f_{R1-S1} and f_{R1-S2} bits in the reference counter program word. The 14-bit auxiliary reference frequency counter data will be in Don't Care state.

If the 14-bit auxiliary reference frequency counter is enabled (auxiliary reference enable = 1), the f_{R2} is automatically connected to point D (14-bit counter output), and f_{R1} can be selected to connect to point A, B, or C, depending on the bit setting of f_{R1-S1} and f_{R1-S2} .

Table 4 and Figure 16 describe the functions of the auxiliary reference enable bit and the f_{R1-S1} and f_{R1-S2} bits selection.

Table 4. Bit Function and the Reference Frequency Selection Bit Setting of the Reference Frequency Counter Programming Word

AUX REF Enable	Auxiliary Reference Frequency Counter Mode	Module Select	N/A Not Applicable		
			f_{R1-S1}	f_{R1-S2}	f_{R1} Routing
0	14-Bit Auxiliary Reference Frequency Counter Disable	$f_{R2} \rightarrow C$	0	0	N/A
			0	1	$f_{R1} \rightarrow A$
			1	0	$f_{R1} \rightarrow B$
			1	1	N/A
1	14-Bit Auxiliary Reference Frequency Counter Disable	$f_{R2} \rightarrow D$	0	0	N/A
			0	1	$f_{R1} \rightarrow A$
			1	0	$f_{R1} \rightarrow B$
			1	1	$f_{R1} \rightarrow C$

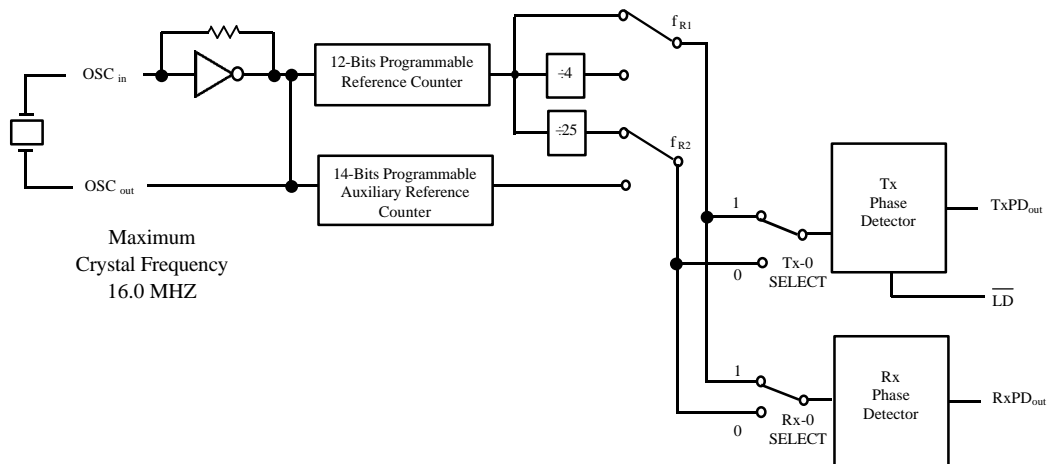

Maximum
Crystal Frequency
16.0 MHZ

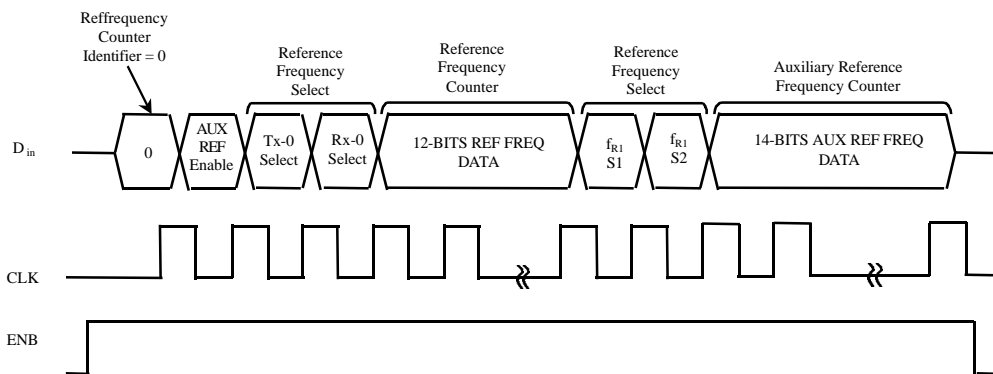

NOTE: ENB must be high during the serial transfer.

Figure 16. Reference Frequency Counter/selection Programming Mode

POWER SAVING OPERATION

This PLL has a programmable power-saving scheme. The transmit counter, receive counter and the reference frequency counter can be powered down individually by setting the TxPD enable, RxPD enable and Ref PD enable bits of the control register. The functions of the power down control bits are explained in Table 2 and the programming format is in Figure 8.

The output pins TxPS/f_{Tx} and RxPS/f_{Rx} output the

status of the internal power saving setting. If the bit TxPD enable is set high (transmit counter is set to power-down mode), then the TxPS/f_{Tx} pin will also output a high state. This TxPS/f_{Tx} output can control an external power switch to switch off the transmitter, as shown in Figure 17. This scheme can be applied to the RxPS/f_{Rx} output to control the receiver power saving operation as required.

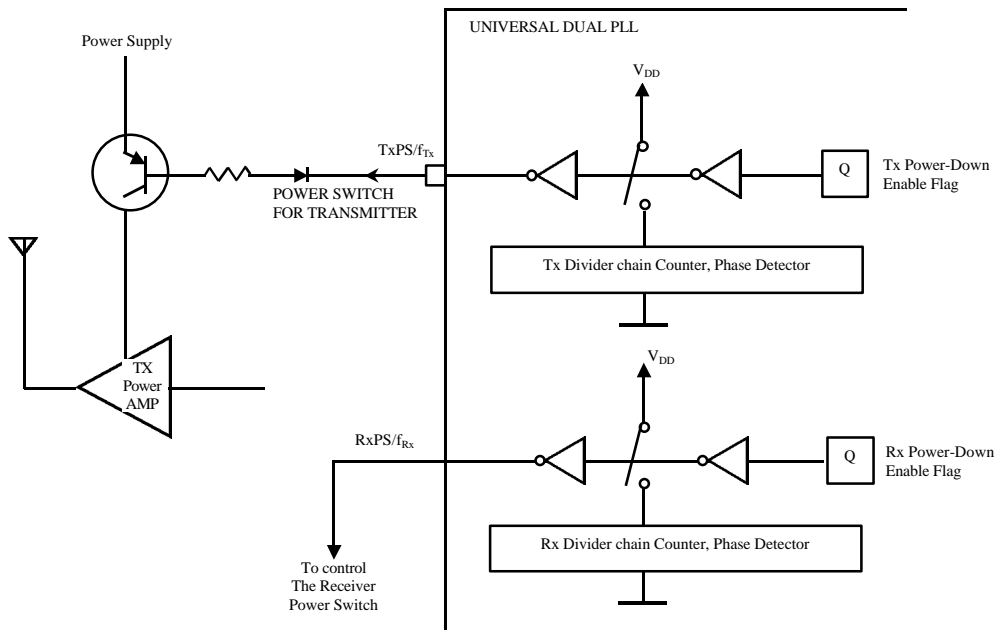

Figure 17. TxPS/f_{Tx} and RxPS/f_{Rx} Outputs to Control Power Switches of the Transmitter and Receiver

TX/RX CHANNEL COUNTER TEST

In normal applications, the $TxPS/f_{Tx}$ and the $RxPS/f_{Rx}$ output pins indicate the power saving mode status. However, the user can examine the Tx and Rx channel counter outputs by setting the Test bit in the control register to 1. The final value of the transmit-channel counter and the receive-

channel counter multiplex out to $TxPS/f_{Tx}$ and $RxPS/f_{Rx}$ respectively. The user can verify the divided-down output waveform associated with the RF input level in the PLL circuitry implementation (Figure 18).

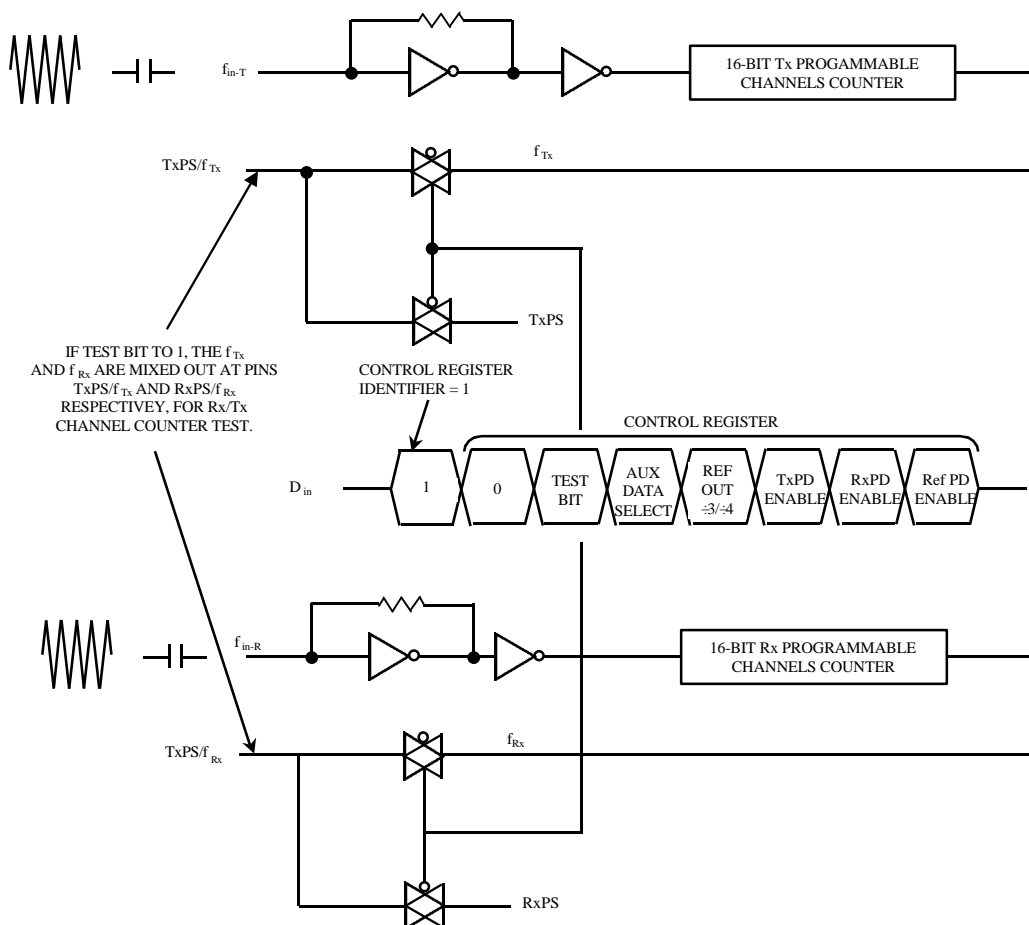

Figure 18. RF Buffer Sensitivity

Table 5. France CT-1 Base Set Frequency

Channel Number	Tx-Channel Frequency (MHz)	Tx Counter Value (Ref. Freq.= 6.25 KHz)	f_{in-R} Input Frequency(MHz) [1st IF = 10.7MHz]	Rx Counter Value (Ref. Freq. = 6.25 KHz)
1	26.4875	4238	30.7875	4926
2	26.4750	4236	30.7750	4924
3	26.4625	4234	30.7625	4922
4	26.4500	4232	30.7500	4920
5	26.4375	4230	30.7375	4918
6	26.4250	4228	30.7250	4916
7	26.4125	4226	30.7125	4914
8	26.4000	4224	30.7000	4912
9	26.3875	4222	30.6875	4910
10	26.3750	4220	30.6750	4908
11	26.3625	4218	30.6625	4906
12	26.3500	4216	30.6500	4904
13	26.3375	4214	30.6375	4902
14	26.3250	4212	30.6250	4900
15	26.3125	4210	30.6125	4898

Table 6. France CT-1 Hand Set Frequency

Channel Number	Tx-Channel Frequency (MHz)	Tx Counter Value (Ref. Freq. = 6.25 KHz)	f_{in-R} Input Frequency(MHz) [1st IF = 10.7MHz]	Rx Counter Value (Ref. Freq. = 6.25 KHz)
1	41.4875	6638	37.1875	5950
2	41.4750	6636	37.1750	5948
3	41.4625	6634	37.1625	5946
4	41.4500	6632	37.1500	5944
5	41.4375	6630	37.1375	5942
6	41.4250	6628	37.1250	5940
7	41.4125	6626	37.1125	5938
8	41.4000	6624	37.1000	5936
9	41.3875	6622	37.0875	5934
10	41.3750	6620	37.0750	5932
11	41.3625	6618	37.0625	5930
12	41.3500	6616	37.0500	5928
13	41.3375	6614	37.0375	5926
14	41.3250	6612	37.0250	5924
15	41.3125	6610	37.0125	5922

Table 7. Spain CT – 1 Base Set Frequency

Channel Number	Tx-Channel Frequency (MHz)	Tx Counter Value (Ref. Freq. = 5.00KHz)	f_{in-R} Input Frequency (MHz) [1 st IF= 10.695 MHz]	Rx counter value (Ref. Freq.=5.00KHz)
1	31.0250	6205	29.2300	5846
2	31.0500	6210	29.2550	5851
3	31.0750	6215	29.2800	5856
4	31.1000	6220	29.3050	5861
5	31.1250	6225	29.3300	5866
6	31.1500	6230	29.3550	5871
7	31.1750	6235	29.3800	5876
8	31.2000	6240	29.4050	5881
9	31.2500	6250	29.4550	5891
10	31.2750	6255	29.4800	5896
11	31.3000	6260	29.5050	5901
12	31.3250	6265	29.5300	5906

Table 8. Spain CT – 1 Hand Set Frequency

Channel Number	Tx-Channel Frequency (MHz)	Tx Counter Value (Ref. Freq. = 5.00KHz)	f_{in-R} Input Frequency (MHz) [1 st IF= 10.7 MHz]	Rx counter value (Ref. Freq.=5.00KHz)
1	39.9250	7985	20.3300	4066
2	39.9500	7990	20.3550	4071
3	39.9750	7995	20.3800	4076
4	40.0000	8000	20.4050	4081
5	40.0250	8005	20.4300	4086
6	40.0500	8010	20.4550	4091
7	40.0750	8015	20.4800	4096
8	40.1000	8020	20.5050	4101
9	40.1500	8030	20.5550	4111
10	40.1750	8035	20.5800	4116
11	40.2000	8040	20.6050	4121
12	40.2250	8045	20.6300	4126

Table 9. New Zealand CT – 1 Base Set Frequency

Channel Number	Tx-Channel Frequency (MHz)	Tx Counter Value	f_{in-R} Input Frequency (MHz) [1 st IF= 10.7 MHz]	Rx counter value (Ref. Freq.=6.25KHz)
1	1.7820	1782	29.7625	4762
2	1.7620	1762	29.7500	4760
3	1.7420	1742	29.7375	4758
4	1.7220	1722	29.7250	4756
5	1.7020	1702	29.7125	4754
6	34.3500	5496	29.7000	4752
7	34.3625	5498	29.6875	4750
8	34.3750	5500	29.6750	4748
9	34.3875	5502	29.6625	4746
10	34.4000	5504	29.6500	4744

Table 10. New Zealand CT – 1 Hand Set Frequency

Channel Number	Tx-Channel Frequency (MHz)	Tx Counter Value (Ref. Freq. = 6.25KHz)	f_{in-R} Input Frequency (MHz)	Rx counter value
1	40.4625	6474	2.2370	2237
2	40.4500	6472	2.2170	2217
3	40.4375	6470	2.1970	2197
4	40.4250	6468	2.1770	2177
5	40.4125	6466	2.1570	2157
6	40.4000	6464	23.6500	3784
7	40.3875	6462	2.6625	3786
8	40.3750	6460	23.6750	3788
9	40.3625	6458	23.6875	3790
10	40.3500	6456	23.7000	3792

Table 11. Australia CT – 1 Base Set Frequency

Channel Number	Tx-Channel Frequency (MHz)	Tx Counter Value (Ref. Freq. = 5.00KHz)	f_{in-R} Input Frequency (MHz) [1 st IF= 10.695 MHz]	Rx counter value (Ref. Freq.=5.00KHz)
1	30.0750	6015	29.0800	5816
2	30.1250	6025	29.1300	5826
3	30.1750	6035	29.1800	5836
4	30.2250	6045	29.2300	5846
5	30.2750	6055	29.2800	5856
6	30.1000	6020	29.1050	5821
7	30.1500	6030	29.1550	5831
8	30.2000	6040	29.2050	5841
9	30.2500	6050	29.2550	5851
10	30.3000	6060	29.3050	5861

Table 12. Australia CT – 1 Hand Set Frequency

Channel Number	Tx-Channel Frequency (MHz)	Tx Counter Value (Ref. Freq. = 5.00KHz)	F_{in-R} Input Frequency (MHz) [1 st IF= 10.7 MHz]	Rx counter value (Ref. Freq.=5.00KHz)
1	39.7750	7955	19.3800	3876
2	38.8250	7965	19.4300	3886
3	37.8750	7975	19.4800	3896
4	36.9250	7985	19.5300	3906
5	35.9750	7995	19.5800	3916
6	39.8000	7960	19.4050	3881
7	39.8500	7970	19.4550	3891
8	39.9000	7980	19.5050.	3901
9	39.9500	7990	19.5550	3911
10	40.0000	8000	19.6050	3921

Table 13. U.K. CT – 1 Base Set Frequency

Channel Number	Tx-Channel Frequency (MHz)	Tx Counter Value (Ref. Freq. = 1.00KHz)	f_{in-R} Input Frequency (MHz) [1 st IF= 10.7 MHz]	Rx counter value (Ref. Freq.=6.25KHz)
1	1.6420	1642	36.75625	5881
2	1.6620	1662	36.76875	5883
3	1.6820	1682	36.78125	5885
4	1.7020	1702	36.79375	5887
5	1.7220	1722	36.80625	5889
6	1.7420	1742	36.81875	5891
7	1.7620	1762	36.83125	5893
8	1.7820	1782	36.84375	5895

Table 14. U.K. CT – 1 Hand Set Frequency

Channel Number	Tx-Channel Frequency (MHz)	Tx Counter Value (Ref. Freq. = 0.25KHz)	f_{in-R} Input Frequency (MHz) [1 st IF= 45.5 KHz]	Rx counter value (Ref. Freq.=1.00KHz)
1	47.45625	7593	2.097	2097
2	47.46875	7595	2.117	2117
3	47.48125	7597	2.137	2137
4	47.49375	7599	2.157	2157
5	47.50625	7601	2.177	2177
6	47.51875	7603	2.197	2197
7	47.53125	7605	2.217	2217
8	47.54375	7607	2.237	2237

Table 15. U.S.A. CT-1 Base Set Frequency

Channel Number	Tx-Channel Frequency (MHz)	Tx Counter Value (Ref.Freq. = 5.00 KHz)	f_{in-R} Input Frequency (MHz) [1st IF=10.695 MHz]	Rx Counter Value (Ref. Freq. = 5.00 KHz)
1	46.610	9322	38.975	7795
2	46.630	9326	38.150	7830
3	46.670	9334	38.165	7833
4	46.710	9342	39.075	7815
5	46.730	9346	39.180	7836
6	46.770	9354	39.135	7827
7	46.830	9366	39.195	7839
8	46.870	9374	39.235	7847
9	46.930	9386	39.295	7859
10	46.970	9394	39.275	7855

Table 16. U.S.A. CT-1 Hand Set Frequency

Channel Number	Tx-Channel Frequency (MHz)	Tx Counter Value (Ref.Freq. = 5.00 KHz)	f_{in-R} Input Frequency (MHz) [1st IF=10.7 MHz]	Rx Counter Value (Ref. Freq. = 5.00 KHz)
1	49.670	9934	35.915	7183
2	49.845	9969	35.935	7187
3	49.860	9972	35.975	7195
4	49.770	9954	36.015	7203
5	49.875	9975	36.035	7207
6	49.830	9966	36.075	7215
7	49.890	9978	36.135	7227
8	49.930	9986	36.175	7235
9	49.990	9998	36.235	7247
10	49.970	9994	36.275	7255

Table 17. U.S.A. CT-1 Base Set Frequency

Channel Number	Tx-Channel Frequency (MHz)	Tx Counter Value (Ref.Freq. = 5.00 KHz)	f_{in-R} Input Frequency (MHz) [1st IF=10.7 MHz]	Rx Counter Value (Ref. Freq. = 5.00 KHz)
1	43.72	8744	38.06	7612
2	43.74	8748	38.14	7628
3	43.82	8764	38.16	7632
4	43.84	8768	38.22	7644
5	43.92	8784	38.32	7664
6	43.96	8788	38.38	7678
7	44.12	8824	38.40	7680
8	44.16	8832	38.46	7692
9	44.18	8836	38.50	770
10	44.20	8840	38.54	7708
11	44.32	8864	38.58	7716
12	44.36	8872	38.66	7732
13	44.40	8880	38.70	7740
14	44.46	8892	38.76	7752
15	44.48	8896	38.80	7760
16	46.61	9322	38.97	7794
17	46.63	9326	39.145	7829
18	46.67	9331	39.16	7832
19	46.71	9342	39.07	7814
20	46.73	9346	39.175	7835
21	46.77	9354	39.13	7826
22	46.83	9366	39.19	7838
23	46.87	9374	39.23	7846
24	46.93	9386	39.29	7858
25	46.97	9394	39.27	7854

Table 18 U.S.A. CT-1 Hand Set Frequency

Channel Number	Tx-Channel Frequency (MHz)	Tx Counter Value (Ref.Freq. = 5.00 KHz)	f_{in-R} Input Frequency (MHz) [1st IF=10.7 MHz]	Rx Counter Value (Ref. Freq. = 5.00 KHz)
1	48.76	9752	33.02	6604
2	48.84	9768	33.04	6608
3	48.86	9772	33.12	6624
4	48.92	9748	33.14	6628
5	49.02	9804	33.22	6644
6	49.08	9816	33.26	6652
7	49.10	9820	33.42	6684
8	49.16	9832	33.46	6692
9	49.20	9840	33.48	6696
10	49.24	9848	33.50	6700
11	49.28	9856	33.62	6724
12	49.36	9872	33.66	6732
13	49.40	9880	33.70	6740
14	49.46	9892	33.76	6752
15	49.50	9900	33.78	6756
16	49.67	9934	33.91	7182
17	49.845	9969	33.93	7186
18	49.88	9972	33.97	7194
19	49.77	9954	36.01	7202
20	49.875	9975	36.03	7206
21	49.83	9966	36.07	7214
22	449.89	9978	36.13	7226
23	49.93	9986	36.17	7234
24	49.99	9998	36.23	7246
25	49.97	9994	36.27	7254

Table 19 Korea CT-1 Base Set Frequency

Channel Number	Tx-Channel Frequency (MHz)	Tx Counter Value (Ref.Freq. = 5.00 KHz)	f_{in-R} Input Frequency (MHz) [1st IF=10.695 MHz]	Rx Counter Value (Ref. Freq. = 5.00 KHz)
1	46.610	9322	38.975	7795
2	46.630	9326	38.150	7830
3	46.670	9334	38.165	7833
4	46.710	9342	39.075	7815
5	46.730	9346	39.180	7836
6	46.770	9354	39.135	7827
7	46.830	9366	39.195	7839
8	46.870	9374	39.235	7847
9	46.930	9386	39.295	7859
10	46.970	9394	39.275	7855
11	46.510	9302	39.000	7800
12	46.530	9306	39.015	7803
13	46.550	9310	39.030	7806
14	46.570	9314	39.045	7809
15	46.590	9318	39.060	7812

Table 20. Korea CT-1 Hand Set Frequency

Channel Number	Tx-Channel Frequency (MHz)	Tx Counter Value (Ref.Freq. = 5.00 KHz)	f_{in-R} Input Frequency (MHz) [1st IF=10.7 MHz]	Rx Counter Value (Ref. Freq. = 5.00 KHz)
1	49.670	9934	35.915	7183
2	49.845	9969	35.935	7187
3	49.860	9972	35.975	7195
4	49.770	9954	36.015	7203
5	49.875	9975	36.035	7207
6	49.830	9966	36.075	7215
7	49.890	9978	36.135	7227
8	49.930	9986	36.175	7235
9	49.990	9998	36.235	7247
10	49.970	9994	36.275	7255
11	49.695	9939	35.815	7163
12	49.710	9942	35.835	7167
13	49.725	9945	35.855	7171
14	49.740	9948	35.875	7175
15	49.755	9951	35.895	7179