

TA8413P

3 PHASE BI-DIRECTIONAL HALL MOTOR CONTROL IC

FEATURES

- FG is not required.
(System for obtaining rotation signal through position sensing)
- Start/stop, CW/CCW and brake function is provided.
- Gain of position sensing circuit is high, and hysteresis is provided.
- Rotation signal output is provided.
(Frequency signal of three times the position sensing output (hall element output) can be obtained.)
- External transistor type.

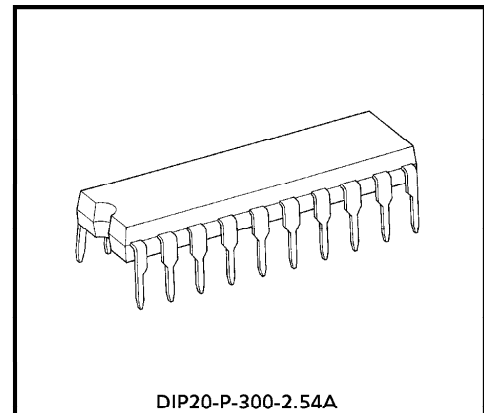

Weight : 2.25g (Typ.)

BLOCK DIAGRAM

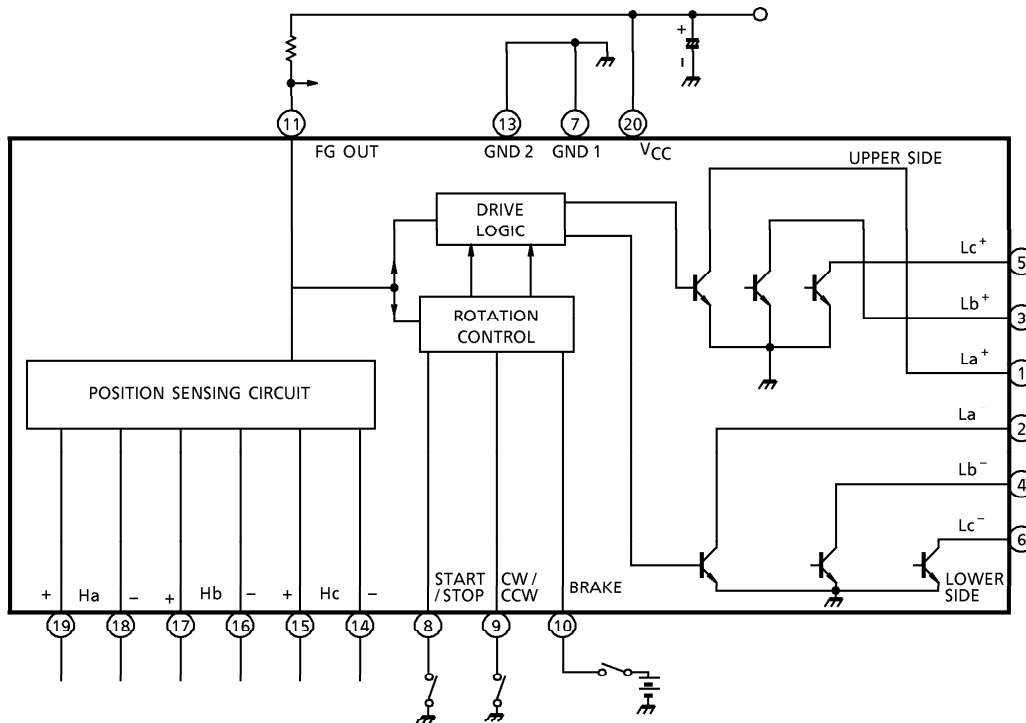

961001EBA2

● TOSHIBA is continually working to improve the quality and the reliability of its products. Nevertheless, semiconductor devices in general can malfunction or fail due to their inherent electrical sensitivity and vulnerability to physical stress. It is the responsibility of the buyer, when utilizing TOSHIBA products, to observe standards of safety, and to avoid situations in which a malfunction or failure of a TOSHIBA product could cause loss of human life, bodily injury or damage to property. In developing your designs, please ensure that TOSHIBA products are used within specified operating ranges as set forth in the most recent products specifications. Also, please keep in mind the precautions and conditions set forth in the TOSHIBA Semiconductor Reliability Handbook.

PIN FUNCTION

PIN No.	SYMBOL	FUNCTION DESCRIPTION
1	La ⁺	a-phase upper drive output terminal.
2	La ⁻	a-phase lower drive output terminal.
3	Lb ⁺	b-phase upper drive output terminal.
4	Lb ⁻	b-phase lower drive output terminal.
5	Lc ⁺	c-phase upper drive output terminal.
6	Lc ⁻	c-phase lower drive output terminal.
7	GND1	GND1 terminal.
8	START/STOP	Start/stop control terminal.
9	CW/CCW	Forward /Reverse rotation control terminal.
10	BRAKE	Breake terminal.
11	FG OUT	FG signal output terminal.
12	N. C.	Non connection.
13	GND2	GND2 terminal.
14	Hc ⁻	c-phase Hall Amp. negative input terminal.
15	Hc ⁺	c-phase Hall Amp. positive input terminal.
16	Hb ⁻	b-phase Hall Amp. negative input terminal.
17	Hb ⁺	b-phase Hall Amp. positive input terminal.
18	Ha ⁻	a-phase Hall Amp. negative input terminal.
19	Ha ⁺	a-phase Hall Amp. positive input terminal.
20	VCC	Power supply input terminal.

961001EBA2'

- The products described in this document are subject to foreign exchange and foreign trade control laws.
- The information contained herein is presented only as a guide for the applications of our products. No responsibility is assumed by TOSHIBA CORPORATION for any infringements of intellectual property or other rights of the third parties which may result from its use. No license is granted by implication or otherwise under any intellectual property or other rights of TOSHIBA CORPORATION or others.
- The information contained herein is subject to change without notice.

TIMING CHART

Forward rotation (Position sensing signal advances Ha→Hb→Hc.)

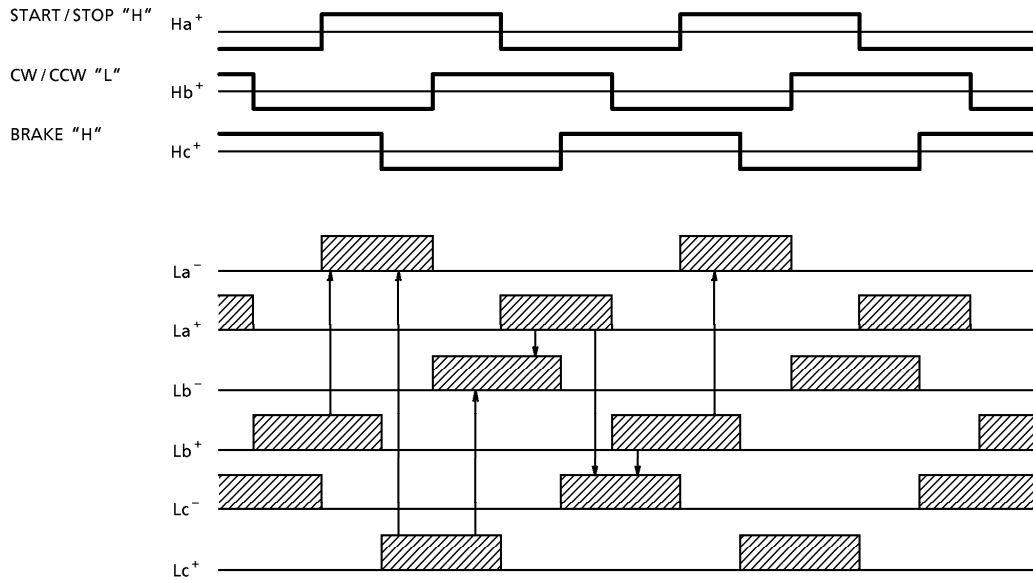

Reverse rotation (Position sensing signal advances Ha→Hc→Hb.)

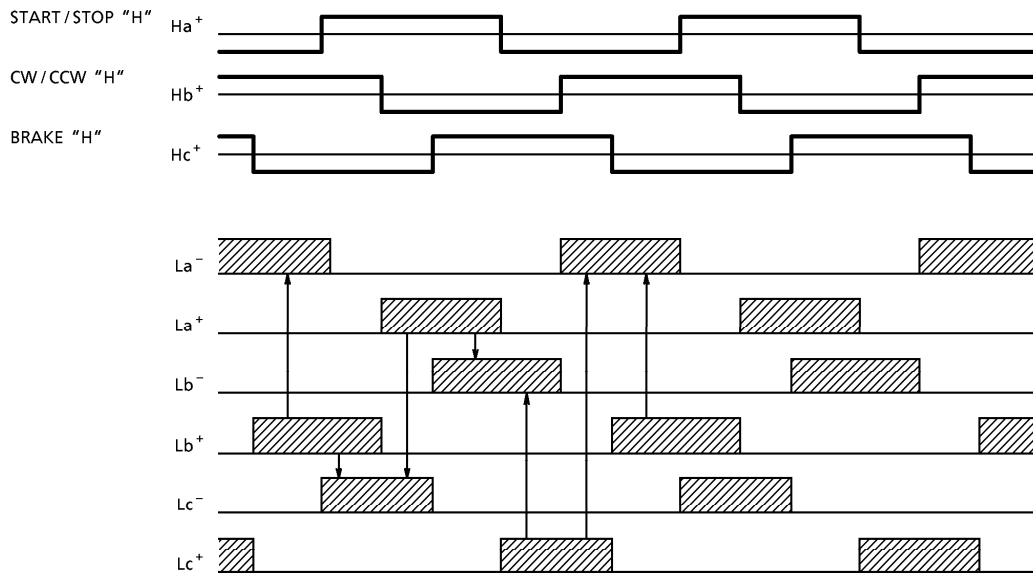

(1) Control input circuit

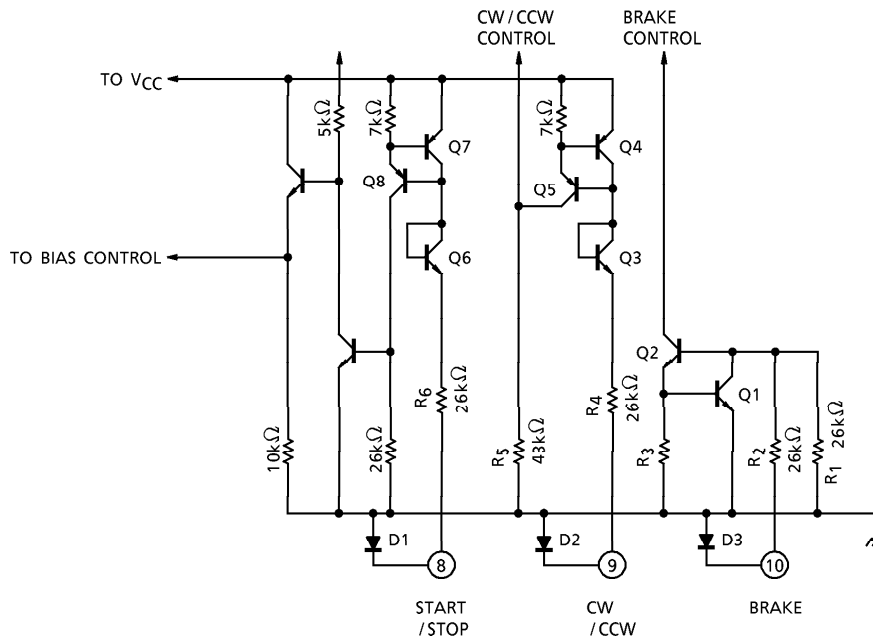

START/STOP and CW/CCW inputs are Low Active and BRAKE input is High Active type. D1~D3 are input protect diodes.

Input current of START/STOP and CW/CCW are calculated by following equations.

$$I_{IN C} = \frac{V_{CC} - V_{INC} - V_{BEQ3} - V_{BEQ4} - V_{BEQ5}}{R_4} \cong \frac{V_{CC} - V_{INC} - 2.1}{26 \times 10^3} \quad (A)$$

(Pin⑨)

$$I_{IN R} = \frac{V_{CC} - V_{INR} - V_{BEQ6} - V_{BEQ7} - V_{BEQ8}}{R_6} \cong \frac{V_{CC} - V_{INR} - 2.1}{26 \times 10^3} \quad (A)$$

(Pin⑧)

And also input current of BRAKE (Pin⑩) is calculated by following equation.

$$I_{IN B} = \frac{V_{INB} - V_{BEQ2} - V_{BEQ3}}{R_2} \cong \frac{V_{INB} - 1.4}{26 \times 10^3} \quad (A)$$

(Pin⑩)

(2) FG output circuit

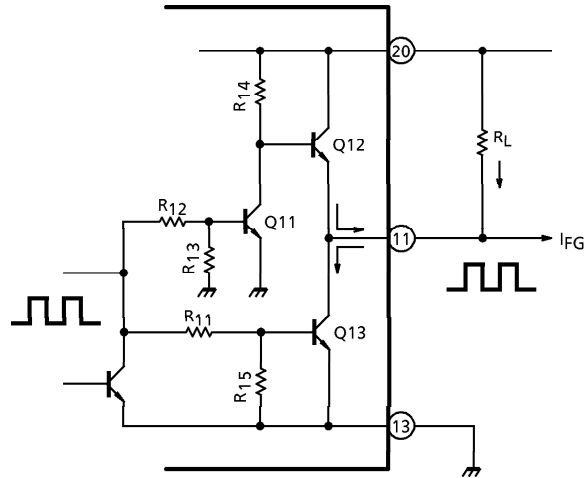

FG signal is generated by the using 3 phase hall signals.
 FG output transistors of Q12 and Q13 work push-pull.
 Specified output voltage generates if load resistor connect to FG output to V_{CC} .

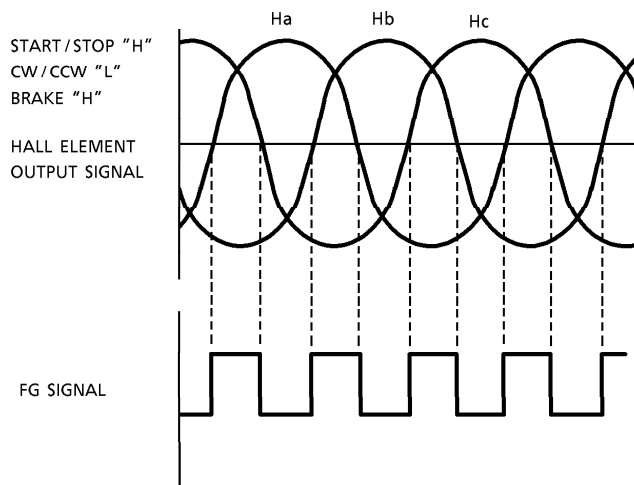

MAXIMUM RATINGS (Ta = 25°C)

CHARACTERISTIC	SYMBOL	RATING	UNIT
Power Supply Voltage	V _{CC}	18	V
Output Current	I _O	± 100	mA
Position Sensing Circuit Input Voltage (T _j = 25°C)	V _H	400	mV _{p-p}
Power Dissipation	P _D (Note)	1.2	W
Operating Temperature	T _{opr}	- 30~75	°C
Storage Temperature	T _{stg}	- 55~150	°C

(Note) No heat sink

ELECTRICAL CHARACTERISTICS (Unless otherwise specified, V_{CC} = 5V, Ta = 25°C)

CHARACTERISTIC		SYMBOL	TEST CIRCUIT	TEST CONDITION	MIN.	TYP.	MAX.	UNIT	
Operation Power Supply Voltage		V _{CC (opr)}	—		4.0	—	18	V	
Power Supply Current		I _{CC1}	1	Stop state	—	4	—	mA	
		I _{CC2}		Output open	—	4	—		
Saturation Voltage	Upper Side	V _{SAT (U-1)}	2	I _O = 10mA	—	1.5	—	V	
		V _{SAT (U-2)}		I _O = 100mA	—	2.0	—		
	Lower Side	V _{SAT (L-1)}		I _O = 10mA	—	0.4	—		
		V _{SAT (L-2)}		I _O = 100mA	—	0.5	1.0		
Leak Current	Upper Side	I _{L (U)}	2	V = 18V	—	—	100	μA	
	Lower Side	I _{L (L)}			—	—	100		
Position Sensing Input	Common Mode Voltage Range		—		2.0	—	V _{CC} - 0.5	V	
	Input Sensitivity				V _H	20	—	—	mV _{p-p}
	Input Hysteresis				V _{H - Hys}	2	7	15	mV
START Input (Low Act)	Operation Input Voltage	"H"	V _{IN R (H)}	2	V _{CC} - 0.9	—	V _{CC}	V	
		"L"	V _{IN R (L)}	2	—	—	1.0		
	Input Current	"L"	I _{IN R}	2	V _{IN R} = 1.0V	—	70	200	μA
CW / CCW Input (Low Act)	Operation Input Voltage	"H"	V _{IN C (H)}	2	V _{CC} - 0.9	—	V _{CC}	V	
		"L"	V _{IN C (L)}	2	—	—	1.0		
	Input Current	"L"	I _{IN C}	2	V _{IN C} = 1.0V	—	70	200	μA
BRAKE Input (High Act)	Operation Input Voltage	"H"	V _{IN B (H)}	2	4.0	—	V _{CC}	V	
		"L"	V _{IN B (L)}	2	—	—	1.0		
	Input Current	"L"	I _{IN B}	3	V _{IN B} = 4V	—	100	250	μA
FG Output	Output Voltage	"H"	V _{FGH}	3	I _{FG} = 1mA	V _{CC} - 1.0	—	—	V
	Output Voltage	"L"	V _{FG L}	3		—	—	0.5	

OUTLINE DRAWING
DIP20-P-300-2.54A

Unit : mm

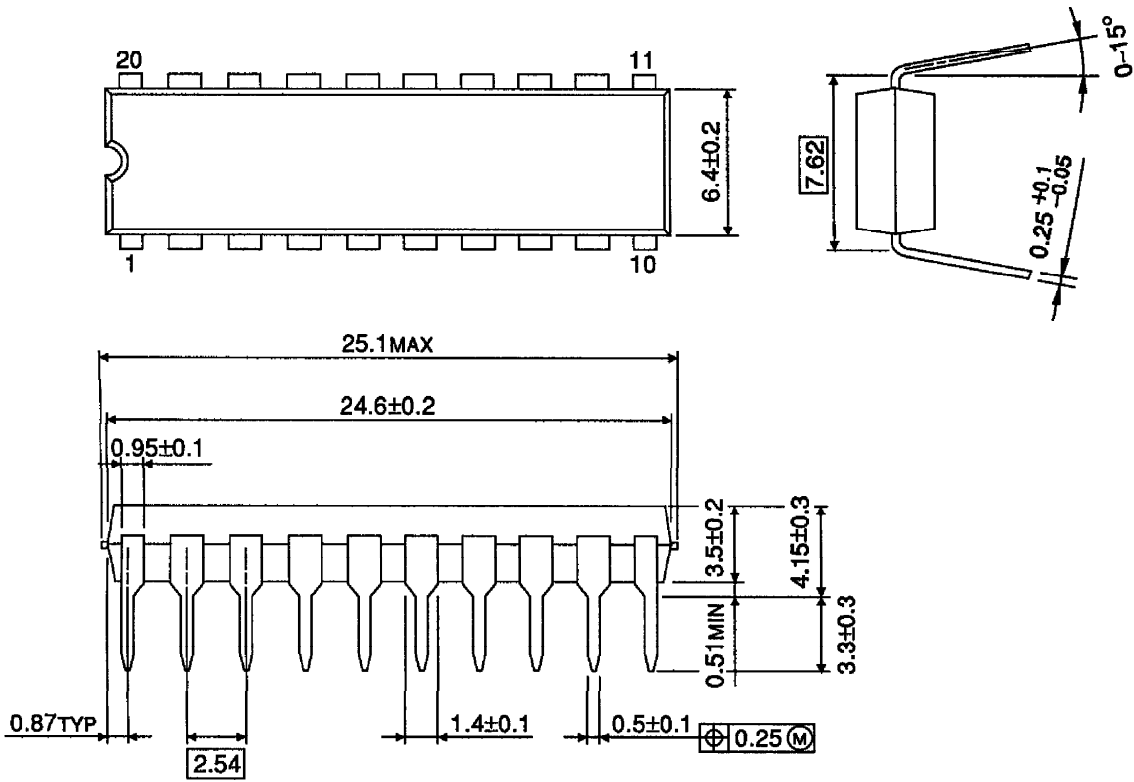

Weight : 2.25g (Typ.)