

DATA SHEET

TDA3833

**BTSC-stereo/SAP/DBX decoder
and DBX expander**

Product specification
File under Integrated Circuits, IC02

September 1992

BTSC-stereo/SAP/DBX decoder and DBX expander**TDA3833****FEATURES**

- DBX decoder, MPX decoder and SAP decoder on chip
- Extensive switching possibilities for the AF outputs and the extra headphone output
- Stereo and SAP signal available simultaneously
- Reliable stereo/SAP identification by means of the noise detector
- Integrated filters
- DAC control possible for most alignments
- Few external components
- Low power consumption (200 mW)
- +5 V supply voltage

GENERAL DESCRIPTION

The TDA3833 is a sound processor for stereo/second audio program (SAP) baseband signals in accordance with the BTSC standard for television receivers and video tape recorders.

QUICK REFERENCE DATA

SYMBOL	PARAMETER	TYP.	UNIT
V_P	positive supply voltage (pin 32)	5	V
I_P	supply current	42	mA
V_i	input signal, 100% modulated, mono (RMS value, pin 1)	100	mV
V_o	AF output signal (RMS value, pins 7, 23 and 24)	550	mV
S/N(W)	signal-to-noise ratio, weighted	50	dB
S/N	signal-to-noise ratio	60	dB
α_{CH}	stereo channel separation	26	dB
α_{CR}	crosstalk attenuation	60	dB
THD	total harmonic distortion	0.2	%

ORDERING INFORMATION

EXTENDED TYPE NUMBER	PACKAGE			
	PINS	PIN POSITION	MATERIAL	CODE
TDA3833	32	SDIL	plastic	SOT232AG ⁽¹⁾
TDA3833T	32	SO	plastic	SOT287AH ⁽²⁾

Note

1. SOT232-1; 1996 December 13.
2. SOT287-1; 1996 December 13.

BTSC-stereo/SAP/DBX decoder and DBX expander

TDA3833

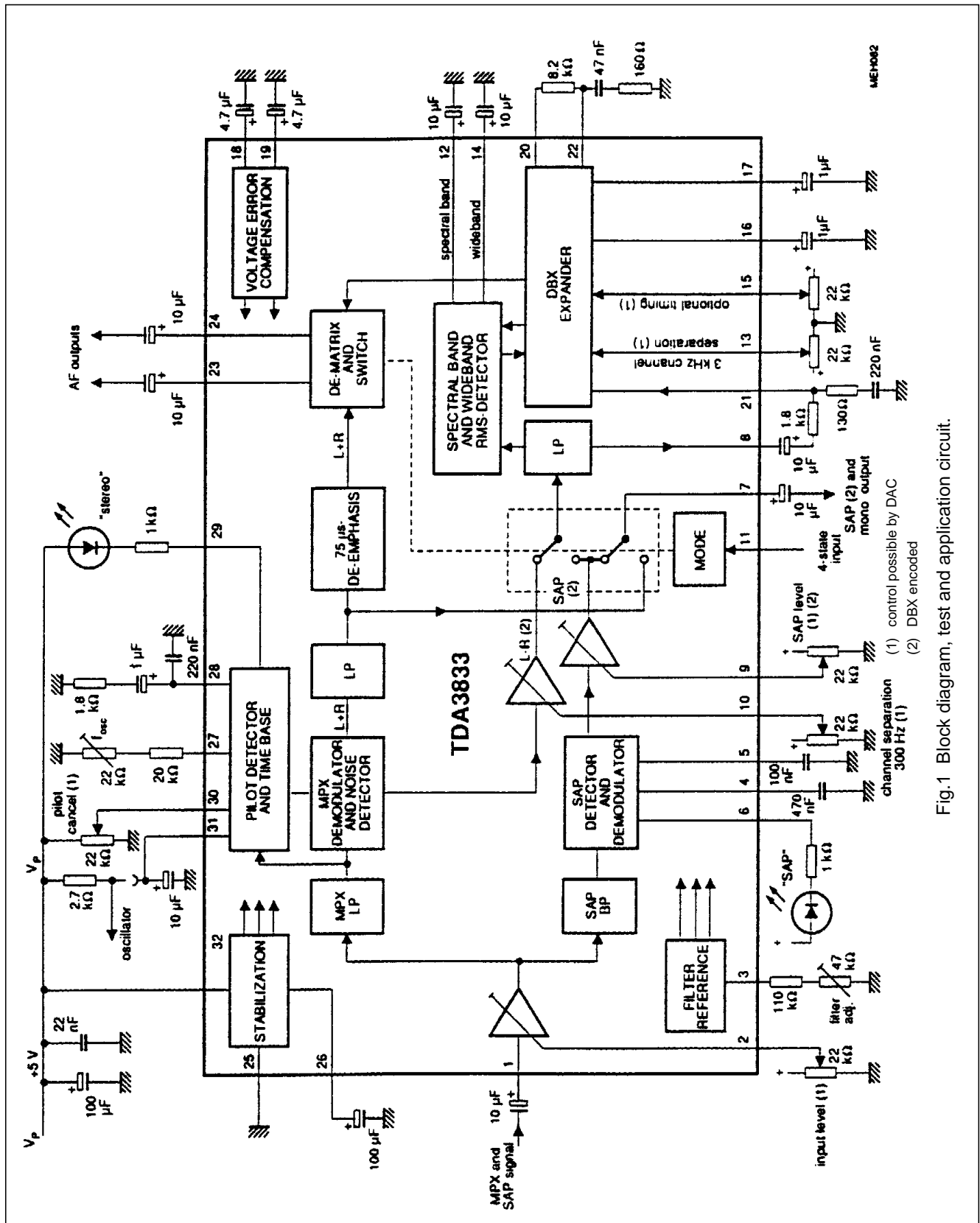

Fig.1 Block diagram, test and application circuit.

BTSC-stereo/SAP/DBX decoder and DBX expander

TDA3833

PINNING

SYMBOL	PIN	DESCRIPTION
V_i	1	composite input signal (MPX/SAP)
ILV	2	input level control
f_{ref}	3	adjustment of filter reference
C_{SAP}	4	SAP identity smoothing capacitor
C_{ND}	5	SAP noise detector smoothing capacitor
SAPI	6	SAP indicator output (sink)
V_{oHP}	7	SAP/mono headphone output
V_{oSAP}	8	output signal SAP/(L-R) without DBX
SAPLV	9	SAP level control
LRLV	10	(L-R) level control
MODE	11	4-state mode control
C_{1SPB}	12	spectral band timing capacitor
DBXLV	13	DBX spectral adjust
C_{1WB}	14	wideband timing capacitor
DBXT	15	DBX timing adjust
C_{2SPB}	16	spectral RMS-detector smoothing capacitor
C_{2WB}	17	wideband RMS-detector smoothing capacitor
C_{1DC}	18	DC decoupling capacitor 1 for offset compensation
C_{2DC}	19	DC decoupling capacitor 2 for offset compensation
EMPH1	20	time constant for variable emphasis
DBXIN	21	DBX signal input
EMPH2	22	time constant for variable emphasis
V_{oAF1}	23	AF output signal right/SAP or mono
V_{oAF2}	24	AF output signal left/SAP or mono
GND	25	ground (0 V)
C_{ref}	26	smoothing capacitor for internal reference voltage
VCO	27	VCO free running frequency adjustment
LOOP	28	phase detector loop filter
STERI	29	stereo indicator output (sink)
PILOT	30	pilot cancel adjustment
C_{pil}	31	pilot detector smoothing capacitor, VCO/4 output
V_P	32	+5 V supply voltage

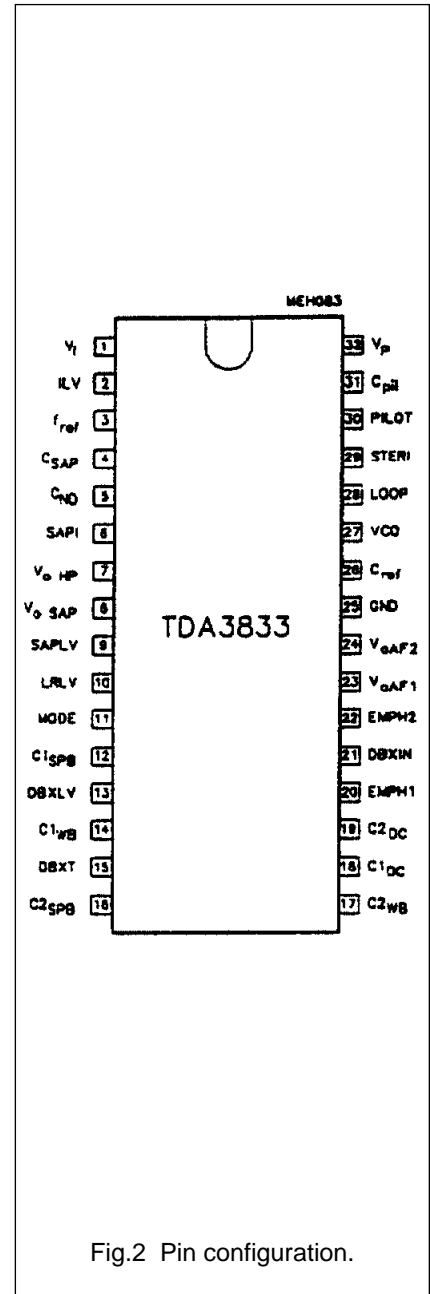

Fig.2 Pin configuration.

BTSC-stereo/SAP/DBX decoder and DBX expander

TDA3833

LIMITING VALUES

In accordance with the Absolute Maximum System (IEC134)

SYMBOL	PARAMETER	MIN.	MAX.	UNIT
V_P	supply voltage (pin 32)	0	8	V
V_1	composite input voltage	0	V_P	V
V_{11}	MODE input voltage	0	8	V
$I_{7,23,24}$	output current (AF outputs)	0	5	mA
$I_{6,29}$	output current (indication outputs)	0	5	mA
P_{tot}	total power dissipation	0	500	mW
T_{stg}	storage temperature range	-55	+150	°C
T_{amb}	operating ambient temperature range	0	+70	°C
V_{ESD}	electrostatic handling for all pins (note 1)	-	±4000	V

Note to the limiting values

- Equivalent to discharging a 100 pF capacitor through an 1.5 kΩ series resistor.

CHARACTERISTICS

$V_P = 5$ V; $T_{amb} = +25$ °C; for MPX: $\Delta f = 25$ kHz for L+R (100% modulation); $f_{mod} = 1$ kHz; and for SAP: $\Delta f = 10$ kHz; $f_{mod} = 1$ kHz, unless otherwise specified. Measurements taken in Fig. 1 including all adjustments.

SYMBOL	PARAMETER	CONDITIONS	MIN.	TYP.	MAX.	UNIT
V_P	supply voltage range (pin 32)		4.75	5	5.35	V
I_P	supply current		-	42	-	mA
V_n	DC input/output voltage at pins 1, 7, 8, 18, 19, 21, 23 and 24		-	$V_P/2$	-	V
MODE select 4-state input (see Table 1)						
V_{11}	input voltage for mono/SAP		0	-	$V_P/2-1$	V
	SAP		$V_P/2-0.4$	-	$V_P/2+0.4$	V
	stereo		$V_P/2+1$	-	V_P	V
	mono		$V_P+1.4$	-	8	V
I_{11}	input current for mono/SAP		-	-	15	μA
	SAP		-	-	15	μA
	stereo		-	-	5	μA
	mono	$V_{11} = 7.2$ V	-	-	300	μA

BTSC-stereo/SAP/DBX decoder and DBX expander

TDA3833

SYMBOL	PARAMETER	CONDITIONS	MIN.	TYP.	MAX.	UNIT
Composite input (pin 1)						
R_i	input resistance on pin 1		14	20	26	$k\Omega$
V_i	input signal on pin 1 (RMS value)	see note 1				
	L+R (all other signals in accordance with BTSC system specification)		70	100	140	mV
	pilot threshold for MPX	stereo on	–	–	16	mV
		stereo off	5	–	–	mV
hysteresis of threshold	MPX	–	2.5	–	dB	
V_i	pilot threshold for SAP	SAP on	–	–	37	mV
		SAP off	16	–	–	mV
	hysteresis of threshold	SAP	–	2	–	dB
G_v	gain control range	dependent on V_2	± 5	± 7.5	–	dB
V_2	control voltage range (pin 2)		–	1 to 4	–	V
I_2	input current (pin 2)	$V_2 = V_P/2$	–	–	5	μA
Voltage controlled oscillator (VCO) (pin 27)						
f_{VCO}	nominal VCO frequency ($4f_H$)	see note 2	–	62.94	–	kHz
Δf_{29}	capture range	nominal pilot	–	–	1	kHz
TC	temperature coefficient		–	–	50	$10^{-6}/K$
Stereo indication output (pin 29)						
V_{29}	output voltage range	stereo present	–	–	0.5	V
		stereo not present	$V_P - 0.5$	–	V_P	V
I_{29}	output current active LOW	stereo present	3	–	–	mA
SAP/mono output (pin 7)						
V_o	output signal (RMS value, pin 7)	see note 3	–	550	–	mV
	output signal headroom	mono	–	9.5	–	dB
R_7	output resistance		–	100	200	Ω
R_L	load resistance		10	–	–	$k\Omega$
C_L	load capacitance		–	–	500	pF
THD	total harmonic distortion	SAP signal	–	0.5	–	%
		mono signal	–	0.2	–	%
B	frequency response 50 to 10000 Hz	mono; external 75 μs de-emphasis	–3	–	–	dB
S/N(W)	weighted signal-to-noise ratio (CCIR468-3)	mono; external 75 μs de-emphasis	–	50	–	dB

BTSC-stereo/SAP/DBX decoder and DBX expander

TDA3833

SYMBOL	PARAMETER	CONDITIONS	MIN.	TYP.	MAX.	UNIT
SAP indication output (pin 6)						
V_6	output voltage range	SAP present	–	–	0.5	V
		SAP not present	$V_P-0.5$	–	V_P	V
I_6	output current active LOW	SAP present	3	–	–	mA
Audio outputs (pins 23 and 24)						
V_o	output signal (RMS value, pins 23 and 24)	see note 3	–	550	–	mV
	output signal headroom		–	9.5	–	dB
$\Delta V_{L,R}$	output signal difference between L and R	$f = 250$ to 6300 Hz	–	–	3	dB
ΔV_o	output signal difference after switching from L or R to SAP	$f = 250$ to 6300 Hz	–	–	3	dB
$\Delta V_{23,24}$	DC offset voltage after switching	stereo/mono/SAP	–	–	± 100	mV
$R_{23,24}$	output resistance		–	200	300	Ω
R_L	load resistance		10	–	–	k Ω
C_L	load capacitance		–	–	500	pF
THD	total harmonic distortion	L and R signal	–	0.2	–	%
		SAP signal	–	0.5	–	%
B	L and R frequency response	$f = 50$ to 10000 Hz 12 kHz related to 1 kHz	–3	–	–	dB
			–	–3	–	dB
	SAP frequency response	$f = 50$ to 8000 Hz	–3	–	–	dB
S/N(W)	weighted signal-to-noise ratio	L + R signal; CCIR468-3	–	50	–	dB
S/N	unweighted signal-to-noise ratio (RMS value)	L + R signal; $f = 20$ to 20000 Hz	–	60	–	dB
α_{CR}	crosstalk	L or R into SAP	50	63	–	dB
		SAP into L or R	50	70	–	dB
α_{CH}	channel separation (according to DBX requirements)	$f = 100$ to 5000 Hz 10% $75 \mu s$ equivalent input modulation	20	26	–	dB
		1 to 100% $75 \mu s$ equivalent input modulation	15	20	–	dB

BTSC-stereo/SAP/DBX decoder and DBX expander

TDA3833

SYMBOL	PARAMETER	CONDITIONS	MIN.	TYP.	MAX.	UNIT
DBX section						
V ₉	SAP level control voltage range		–	1 to 4	–	V
V ₁₀	(L - R) level control voltage range		–	1 to 4	–	V
V ₁₃	spectral band level control voltage range		–	1.8 to 3.2	–	V
I _{9,10,13}	input current	V _I = 0.5V _P	–	–	5	μA
S ₁	spectral RMS-detector release rate		343	381	419	dB/s
I ₁₂	timing current for nominal release rate of spectral RMS-detector	see note 4	–	22.5	–	μA
	current adjustment range		–	11 to 45	–	μA
S ₂	wideband RMS-detector release rate		112.5	125	137.5	dB/s
I ₁₄	timing current for nominal release rate of wideband RMS-detector	0.33I ₁₂ ; see note 4	–	7.5	–	μA
	current adjustment range		–	4 to 15	–	μA
V ₁₅	timing adjustment		–	1.5 to 3.8	–	V

Notes to the characteristics

- Requirements for the MPX/SAP input signal to ensure correct system performance:
 - Maximum variation of MPX/SAP signal under operating conditions: to be found (1 dB).
 - 3 dB bandwidth \geq 130 kHz ($\Delta f = 25$ kHz).
 - THD (L + R, $\Delta f = 25$ kHz, $f_{\text{mod}} = 1$ kHz): 0.2%.
 - S/N(W), weighted in accordance with CCIR468-3 (L + R, $\Delta f = 25$ kHz for sound carrier, $f_{\text{mod}} = 1$ kHz, 75 μ s de-emphasis; with critical picture modulation): S/N(W) > 44 dB; with sync only: S/N(W) > 54 dB.
 - Spectral spurious attenuation: 40 dB (mainly $n \times f_H$; L + R, $\Delta f = 25$ kHz for sound carrier $f_{\text{mod}} = 1$ kHz, 50 Hz to 100 kHz, no de-emphasis).
 - Maximum white noise level (unweighted, 200 Hz to 100 kHz) to avoid malfunctioning of the identification circuits: 500 mV (RMS).
- Adjustable on pin 27, measurement (f_H) on pin 7 with a 2.7 k Ω resistor connected between V_P and pin 31.
- Can also be aligned to 600 mV (RMS), then identification threshold and AF output headroom will be decreased by 1.6 dB.
- I₁₂ and I₁₄ can be measured via an ammeter connected to 4 V (3.5 to 4.1 V).

BTSC-stereo/SAP/DBX decoder and DBX expander

TDA3833

Table 1 MODE select; 4-state pin 11

MODE	V_{11} ($V_P = 5$ V) (V)	SAP CARRIER	AF OUTPUTS		SAP/MONO OUTPUT PIN 7
			PIN 23	PIN 24	
mono	8	on	mono	mono	SAP without DBX
stereo	V_P	on	right	left	SAP without DBX
SAP	$V_P/2$	on	SAP	SAP	mono
mono/SAP	0	on	SAP	mono	SAP without DBX
mono	8	off	mono	mono	mono
stereo	V_P	off	right	left	mono
SAP	$V_P/2$	off	right	left	mono
mono/SAP	0	off	mute	mono	mono

BTSC-stereo/SAP/DBX decoder and DBX expander

TDA3833

PACKAGE OUTLINES

SDIP32: plastic shrink dual in-line package; 32 leads (400 mil)

SOT232-1

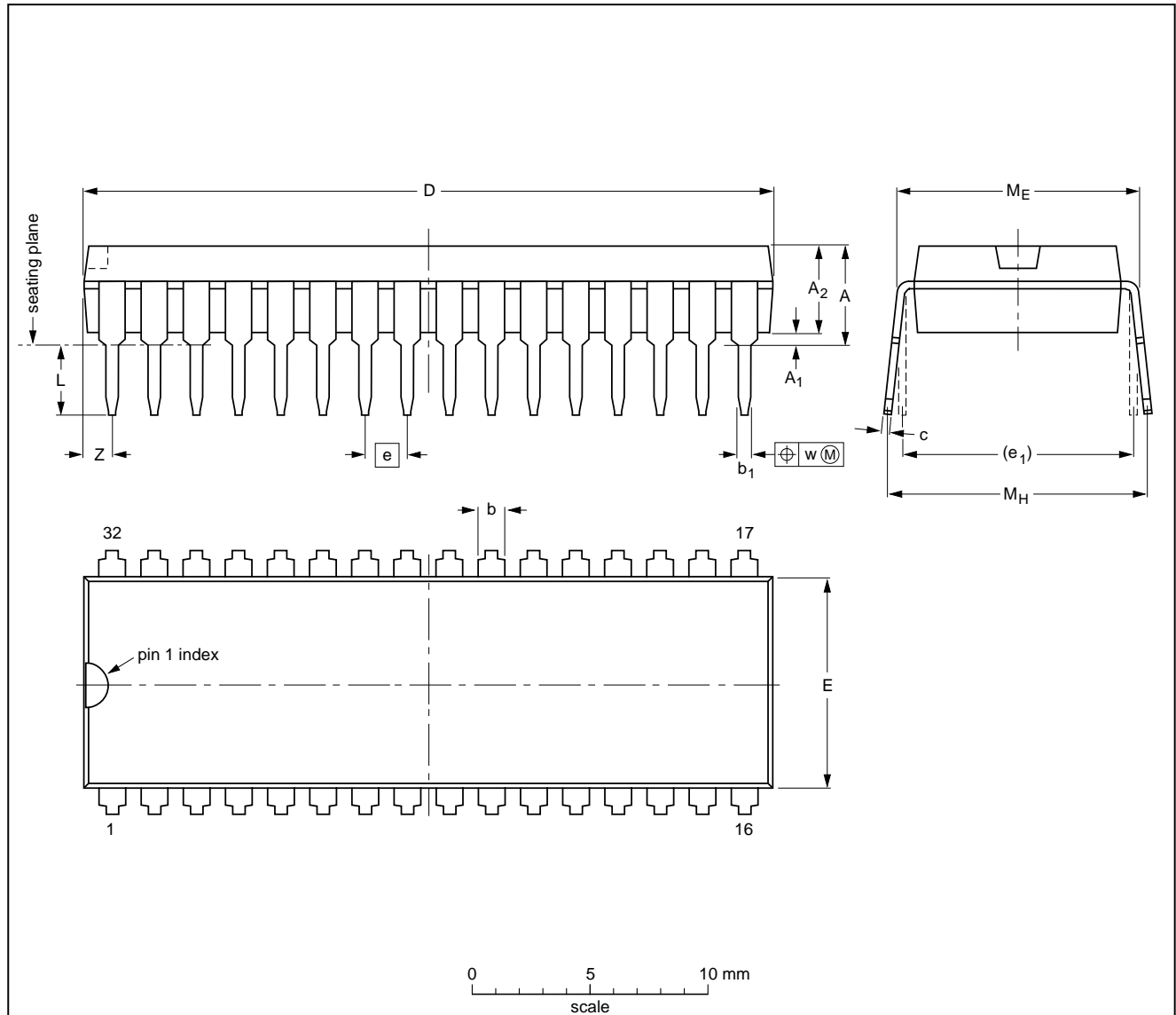

DIMENSIONS (mm are the original dimensions)

UNIT	A max.	A ₁ min.	A ₂ max.	b	b ₁	c	D ⁽¹⁾	E ⁽¹⁾	e	e ₁	L	M _E	M _H	w	Z ⁽¹⁾ max.
mm	4.7	0.51	3.8	1.3 0.8	0.53 0.40	0.32 0.23	29.4 28.5	9.1 8.7	1.778	10.16	3.2 2.8	10.7 10.2	12.2 10.5	0.18	1.6

Note

1. Plastic or metal protrusions of 0.25 mm maximum per side are not included.

OUTLINE VERSION	REFERENCES				EUROPEAN PROJECTION	ISSUE DATE
	IEC	JEDEC	EIAJ			
SOT232-1						92-11-17 95-02-04

BTSC-stereo/SAP/DBX decoder and DBX expander

TDA3833

SO32: plastic small outline package; 32 leads; body width 7.5 mm

SOT287-1

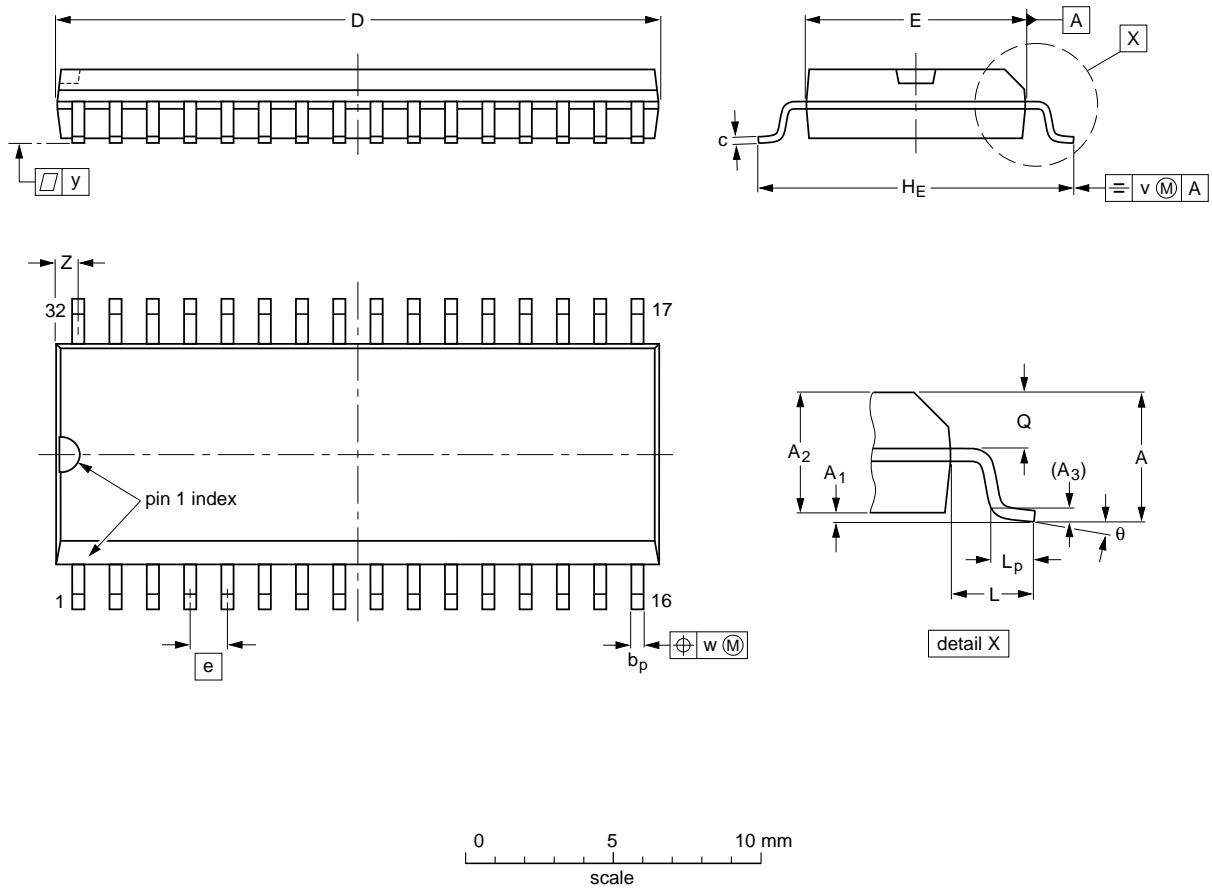

DIMENSIONS (inch dimensions are derived from the original mm dimensions)

UNIT	A max.	A ₁	A ₂	A ₃	b _p	c	D ⁽¹⁾	E ⁽¹⁾	e	H _E	L	L _p	Q	v	w	y	Z ⁽¹⁾	θ
mm	2.65	0.3 0.1	2.45 2.25	0.25	0.49 0.36	0.27 0.18	20.7 20.3	7.6 7.4	1.27	10.65 10.00	1.4	1.1 0.4	1.2 1.0	0.25	0.25	0.1	0.95 0.55	8° 0°
inches	0.10	0.012 0.004	0.096 0.086	0.01	0.02 0.01	0.011 0.007	0.81 0.80	0.30 0.29	0.050	0.42 0.39	0.055	0.043 0.016	0.047 0.039	0.01	0.01	0.004	0.037 0.022	

Note

1. Plastic or metal protrusions of 0.15 mm maximum per side are not included.

OUTLINE VERSION	REFERENCES				EUROPEAN PROJECTION	ISSUE DATE
	IEC	JEDEC	EIAJ			
SOT287-1						92-11-17 95-01-25

BTSC-stereo/SAP/DBX decoder and DBX expander

TDA3833

SOLDERING

Introduction

There is no soldering method that is ideal for all IC packages. Wave soldering is often preferred when through-hole and surface mounted components are mixed on one printed-circuit board. However, wave soldering is not always suitable for surface mounted ICs, or for printed-circuits with high population densities. In these situations reflow soldering is often used.

This text gives a very brief insight to a complex technology. A more in-depth account of soldering ICs can be found in our "IC Package Databook" (order code 9398 652 90011).

SDIP

SOLDERING BY DIPPING OR BY WAVE

The maximum permissible temperature of the solder is 260 °C; solder at this temperature must not be in contact with the joint for more than 5 seconds. The total contact time of successive solder waves must not exceed 5 seconds.

The device may be mounted up to the seating plane, but the temperature of the plastic body must not exceed the specified maximum storage temperature ($T_{stg\ max}$). If the printed-circuit board has been pre-heated, forced cooling may be necessary immediately after soldering to keep the temperature within the permissible limit.

REPAIRING SOLDERED JOINTS

Apply a low voltage soldering iron (less than 24 V) to the lead(s) of the package, below the seating plane or not more than 2 mm above it. If the temperature of the soldering iron bit is less than 300 °C it may remain in contact for up to 10 seconds. If the bit temperature is between 300 and 400 °C, contact may be up to 5 seconds.

SO

REFLOW SOLDERING

Reflow soldering techniques are suitable for all SO packages.

Reflow soldering requires solder paste (a suspension of fine solder particles, flux and binding agent) to be applied to the printed-circuit board by screen printing, stencilling or pressure-syringe dispensing before package placement.

Several techniques exist for reflowing; for example, thermal conduction by heated belt. Dwell times vary between 50 and 300 seconds depending on heating

method. Typical reflow temperatures range from 215 to 250 °C.

Preheating is necessary to dry the paste and evaporate the binding agent. Preheating duration: 45 minutes at 45 °C.

WAVE SOLDERING

Wave soldering techniques can be used for all SO packages if the following conditions are observed:

- A double-wave (a turbulent wave with high upward pressure followed by a smooth laminar wave) soldering technique should be used.
- The longitudinal axis of the package footprint must be parallel to the solder flow.
- The package footprint must incorporate solder thieves at the downstream end.

During placement and before soldering, the package must be fixed with a droplet of adhesive. The adhesive can be applied by screen printing, pin transfer or syringe dispensing. The package can be soldered after the adhesive is cured.

Maximum permissible solder temperature is 260 °C, and maximum duration of package immersion in solder is 10 seconds, if cooled to less than 150 °C within 6 seconds. Typical dwell time is 4 seconds at 250 °C.

A mildly-activated flux will eliminate the need for removal of corrosive residues in most applications.

REPAIRING SOLDERED JOINTS

Fix the component by first soldering two diagonally-opposite end leads. Use only a low voltage soldering iron (less than 24 V) applied to the flat part of the lead. Contact time must be limited to 10 seconds at up to 300 °C. When using a dedicated tool, all other leads can be soldered in one operation within 2 to 5 seconds between 270 and 320 °C.

BTSC-stereo/SAP/DBX decoder and DBX expander

TDA3833

DEFINITIONS

Data sheet status	
Objective specification	This data sheet contains target or goal specifications for product development.
Preliminary specification	This data sheet contains preliminary data; supplementary data may be published later.
Product specification	This data sheet contains final product specifications.
Limiting values	
Limiting values given are in accordance with the Absolute Maximum Rating System (IEC 134). Stress above one or more of the limiting values may cause permanent damage to the device. These are stress ratings only and operation of the device at these or at any other conditions above those given in the Characteristics sections of the specification is not implied. Exposure to limiting values for extended periods may affect device reliability.	
Application information	
Where application information is given, it is advisory and does not form part of the specification.	

LIFE SUPPORT APPLICATIONS

These products are not designed for use in life support appliances, devices, or systems where malfunction of these products can reasonably be expected to result in personal injury. Philips customers using or selling these products for use in such applications do so at their own risk and agree to fully indemnify Philips for any damages resulting from such improper use or sale.