

TENTATIVE TOSHIBA INTELLIGENT POWER DEVICE HIGH VOLTAGE MONOLITHIC SILICON POWER IC

TPD4005K

3-PHASE DC BRUSH LESS MOTOR DRIVER (PWM CIRCUIT NON-INCLUDE)

The TPD4005K is a DC brush less motor driver using high voltage PWM control. It is fabricated by high voltage SOI process. It contains level shift high side driver, low side driver, IGBT outputs, FRDs and protective functions for over current, over heat and under voltage. 5 V C-MOS interface makes it easy to control a DC brush less motor by just putting logic inputs from a micro computer into the TPD4005K.

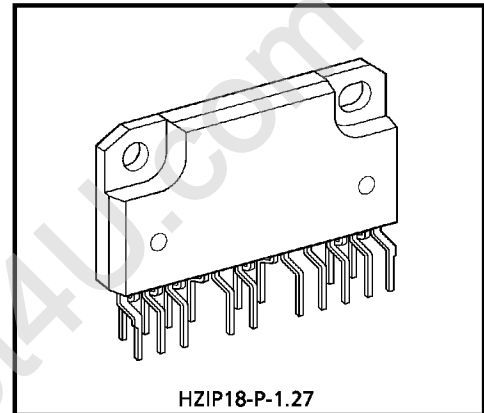

Weight : 5.9 g (Typ.)

FEATURES

- Level shift high side driver is built in
- Bootstrap circuit gives simple high side supply
- 3-phase bridge output using 6 IGBTs
- 6 FRDs are built in
- Protective functions for over current, over heat and under voltage
- Remove a pin between high and low voltage terminals
- 18-pin ZIP package with heat sink

PIN ASSIGNMENT

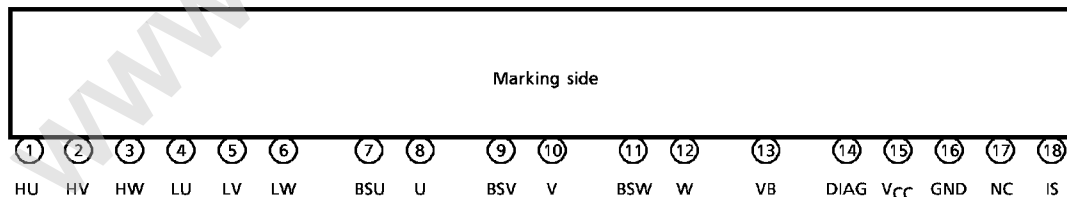

Since this IC is a MOS product, pay attention to static charges when handling it.

- 980910EBA1
- TOSHIBA is continually working to improve the quality and the reliability of its products. Nevertheless, semiconductor devices in general can malfunction or fail due to their inherent electrical sensitivity and vulnerability to physical stress. It is the responsibility of the buyer, when utilizing TOSHIBA products, to observe standards of safety, and to avoid situations in which a malfunction or failure of a TOSHIBA product could cause loss of human life, bodily injury or damage to property. In developing your designs, please ensure that TOSHIBA products are used within specified operating ranges as set forth in the most recent products specifications. Also, please keep in mind the precautions and conditions set forth in the TOSHIBA Semiconductor Reliability Handbook.
 - The products described in this document are subject to the foreign exchange and foreign trade laws.
 - The information contained herein is presented only as a guide for the applications of our products. No responsibility is assumed by TOSHIBA CORPORATION for any infringements of intellectual property or other rights of the third parties which may result from its use. No license is granted by implication or otherwise under any intellectual property or other rights of TOSHIBA CORPORATION or others.
 - The information contained herein is subject to change without notice.

BLOCK DIAGRAM

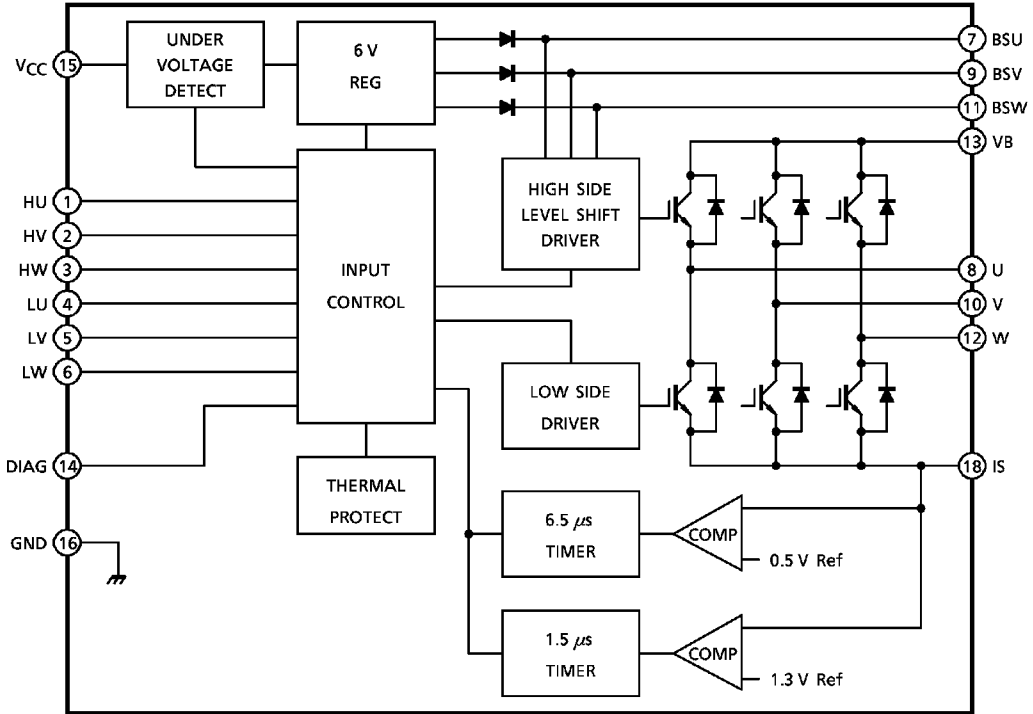

PIN DESCRIPTION

PIN No.	SYMBOL	PIN DESCRIPTION
1	HU	U-phase upper-side IGBT control pin. Turned on at 3.5 V or above; turned off at 1.5 V or below.
2	HV	V-phase upper-side IGBT control pin. Turned on at 3.5 V or above; turned off at 1.5 V or below.
3	HW	W-phase upper-side IGBT control pin. Turned on at 3.5 V or above; turned off at 1.5 V or below.
4	LU	U-phase lower-side IGBT control pin. Turned on at 3.5 V or above; turned off at 1.5 V or below.
5	LV	V-phase lower-side IGBT control pin. Turned on at 3.5 V or above; turned off at 1.5 V or below.
6	LW	W-phase lower-side IGBT control pin. Turned on at 3.5 V or above; turned off at 1.5 V or below.
7	BSU	U-phase upper-side IGBT driver power supply pin. Connect the positive pole of the bootstrap capacitor to this pin.
8	U	Three-phase bridge output, used to connect a motor's U phase. Also, the negative pole of the bootstrap capacitor is connected to this pin.
9	BSV	V-phase upper-side IGBT driver power supply pin. Connect the positive pole of the bootstrap capacitor to this pin.
10	V	Three-phase bridge output, used to connect a motor's V phase. Also, the negative pole of the bootstrap capacitor is connected to this pin.
11	BSW	W-phase upper-side IGBT driver power supply pin. Connect the positive pole of the bootstrap capacitor to this pin.
12	W	Three-phase bridge output, used to connect a motor's W phase. Also, the negative pole of the bootstrap capacitor is connected to this pin.
13	VB	Power supply pin for DC brushless motor drive.
14	DIAG	Diagnostic output pin of open-drain structure. Pull this pin high via a resistor. It outputs a low signal when faulty.
15	V _{CC}	Power supply pin for IC control.
16	GND	Ground pin.
17	NC	Unused pin, which is not connected to the chip internally.
18	IS	Connect a resistor between this pin and GND to sense motor current.

TIMING CHART

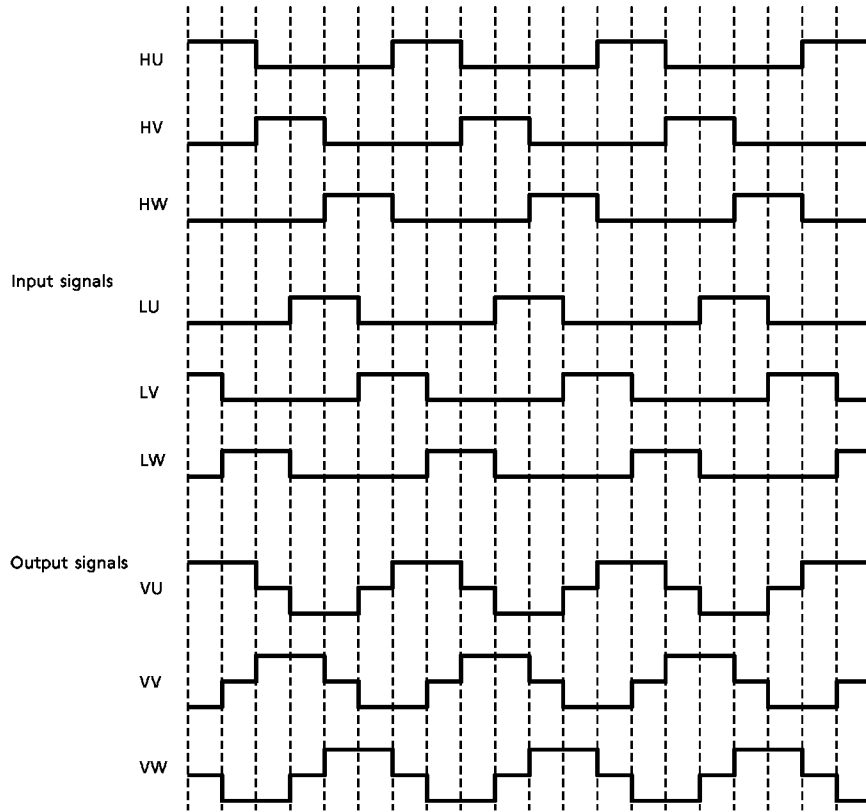

TRUTH TABLE

MODE	INPUT						UPPER ARM			LOWER ARM			DIAG
	HU	HV	HW	LU	LV	LW	U PHASE	V PHASE	W PHASE	U PHASE	V PHASE	W PHASE	
Normal	H	L	L	L	H	L	ON	OFF	OFF	OFF	ON	OFF	H
	H	L	L	L	L	H	ON	OFF	OFF	OFF	OFF	ON	H
	L	H	L	L	L	H	OFF	ON	OFF	OFF	OFF	ON	H
	L	H	L	H	L	L	OFF	ON	OFF	ON	OFF	OFF	H
	L	L	H	H	L	L	OFF	OFF	ON	ON	OFF	OFF	H
	L	L	H	L	H	L	OFF	OFF	ON	OFF	ON	OFF	H
Overcurrent	H	L	L	L	H	L	OFF	OFF	OFF	OFF	OFF	OFF	L
	H	L	L	L	L	H	OFF	OFF	OFF	OFF	OFF	OFF	L
	L	H	L	L	L	H	OFF	OFF	OFF	OFF	OFF	OFF	L
	L	H	L	H	L	L	OFF	OFF	OFF	OFF	OFF	OFF	L
	L	L	H	H	L	L	OFF	OFF	OFF	OFF	OFF	OFF	L
	L	L	H	L	H	L	OFF	OFF	OFF	OFF	OFF	OFF	L
Overheat	H	L	L	L	H	L	OFF	OFF	OFF	OFF	OFF	OFF	L
	H	L	L	L	L	H	OFF	OFF	OFF	OFF	OFF	OFF	L
	L	H	L	L	L	H	OFF	OFF	OFF	OFF	OFF	OFF	L
	L	H	L	H	L	L	OFF	OFF	OFF	OFF	OFF	OFF	L
	L	L	H	H	L	L	OFF	OFF	OFF	OFF	OFF	OFF	L
	L	L	H	L	H	L	OFF	OFF	OFF	OFF	OFF	OFF	L
Under Voltage	H	L	L	L	H	L	OFF	OFF	OFF	OFF	OFF	OFF	L
	H	L	L	L	L	H	OFF	OFF	OFF	OFF	OFF	OFF	L
	L	H	L	L	L	H	OFF	OFF	OFF	OFF	OFF	OFF	L
	L	H	L	H	L	L	OFF	OFF	OFF	OFF	OFF	OFF	L
	L	L	H	H	L	L	OFF	OFF	OFF	OFF	OFF	OFF	L
	L	L	H	L	H	L	OFF	OFF	OFF	OFF	OFF	OFF	L

(Note) : Overheat and under voltage protection are automatically reset. Inputs all low which reset overcurrent protection.

ABSOLUTE MAXIMUM RATING (Ta = 25°C)

CHARACTERISTIC	SYMBOL	RATING	UNIT
Power Supply Voltage	V _{BB}	500	V
	V _{CC}	16	
Output Current (DC)	I _{out}	2	A
Output Current (Startup / Accelerating)	I _{out}	3	A
Input Voltage	V _{IN}	-0.5~6	V
Power Dissipation (Ta = 25°C)	PC	4	W
Power Dissipation (Tc = 25°C)	PC	20	W
Operating Temperature	TOPE	-40~85	°C
Junction Temperature	T _j	150	°C
Storage Temperature	T _{stg}	-55~150	°C

ELECTRICAL CHARACTERISTICS (Ta = 25°C)

CHARACTERISTIC	SYMBOL	TEST CONDITION	MIN	TYP.	MAX	UNIT
Operating Power Supply Voltage	V _{BB}	—	90	—	320	V
	V _{CC}	—	9	12	16	
Operating Current	I _{BB}	V _{BB} = 320 V	—	—	1	mA
	I _{CC}	V _{CC} = 12 V	—	—	5	
Input Voltage	V _{IH}	INPUT = "H"	3.5	—	—	V
	V _{IL}	INPUT = "L"	—	—	1.5	
Input Current	I _{IH}	V _{IN} = 5 V	—	—	100	μA
	I _{IL}	V _{IN} = 0 V	—	—	100	
Output Saturation Voltage	V _{satU}	V _{CC} = 12 V, I _c = 1 A	—	3.0	4.0	V
	V _{satL}	V _{CC} = 12 V, I _c = 1 A	—	3.0	4.0	
FRD Forward Voltage	V _{FU}	I _F = 1 A	—	—	3.0	V
	V _{FL}	I _F = 1 A	—	—	3.0	
Current Limiting Voltage (1)	V _R (1)		—	0.5	—	V
Current Limiting Dead Time (1)	D _t (1)		—	6.5	—	μs
Current Limiting Voltage (2)	V _R (2)		—	1.3	—	V
Current Limiting Dead Time (2)	D _t (2)		—	1.5	—	μs
Overheat Protection Temperature	T _{SD}		150	165	200	°C
Overheat Protection Hysteresis Temperature	ΔT _{SD}		—	10	—	°C
Under Voltage Protection	V _{CCUVD}		6.5	7.5	8.5	V
Under Voltage Protection Recovery	V _{CCUVR}		7.0	8.0	9.0	V
Output Switching Time	t _{on}	I _c = 1 A	—	1	3	μs
	t _{off}	I _c = 1 A	—	1	3	
FRD Reverse Recovery Time	t _{rr}	I _F = 1 A	—	100	200	ns

TYPICAL APPLICATION

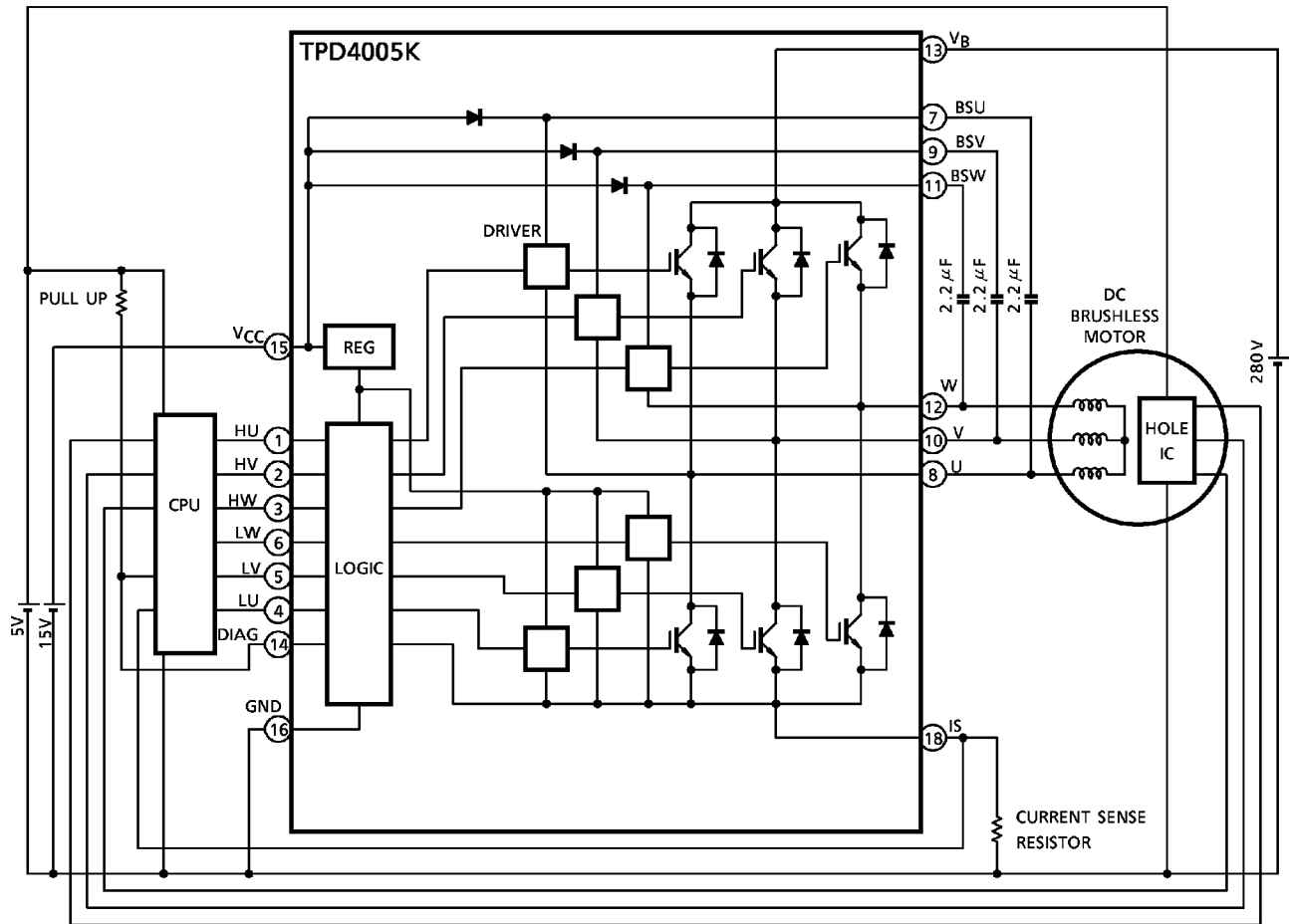

USAGE PRECAUTIONS

- Be sure to observe the sequence in which the power is turned on or off. The power-on sequence is ①V_{CC} → ②V_B; the power-off sequence is ①V_B → ②V_{CC}.
- When PWM operation, be sure to apply PWM chopping on the high side when starting the motor. If low side PWM chopping is applied from the startup, the motor may not be driven because bootstrap capacitor is not charged enough.
- Although the required bootstrap capacitance varies with the motor drive conditions, care must be taken to keep the capacitor voltage above 5 V at startup and during drive.
- Because approximately 6 V is applied across the bootstrap capacitor under normal operating condition, the capacitor must have a sufficient margin for the applied voltage.
- This IC is suitable for the PWM frequency up to 20 kHz. Since ON/OFF switching times requires 2 µs (typ.) each, the higher the PWM frequency, the greater the switching portion compare to the ON duration. This results in an increase of switching loss.

PACKAGE DIMENSION
HZIP18-P-1.27

Unit : mm

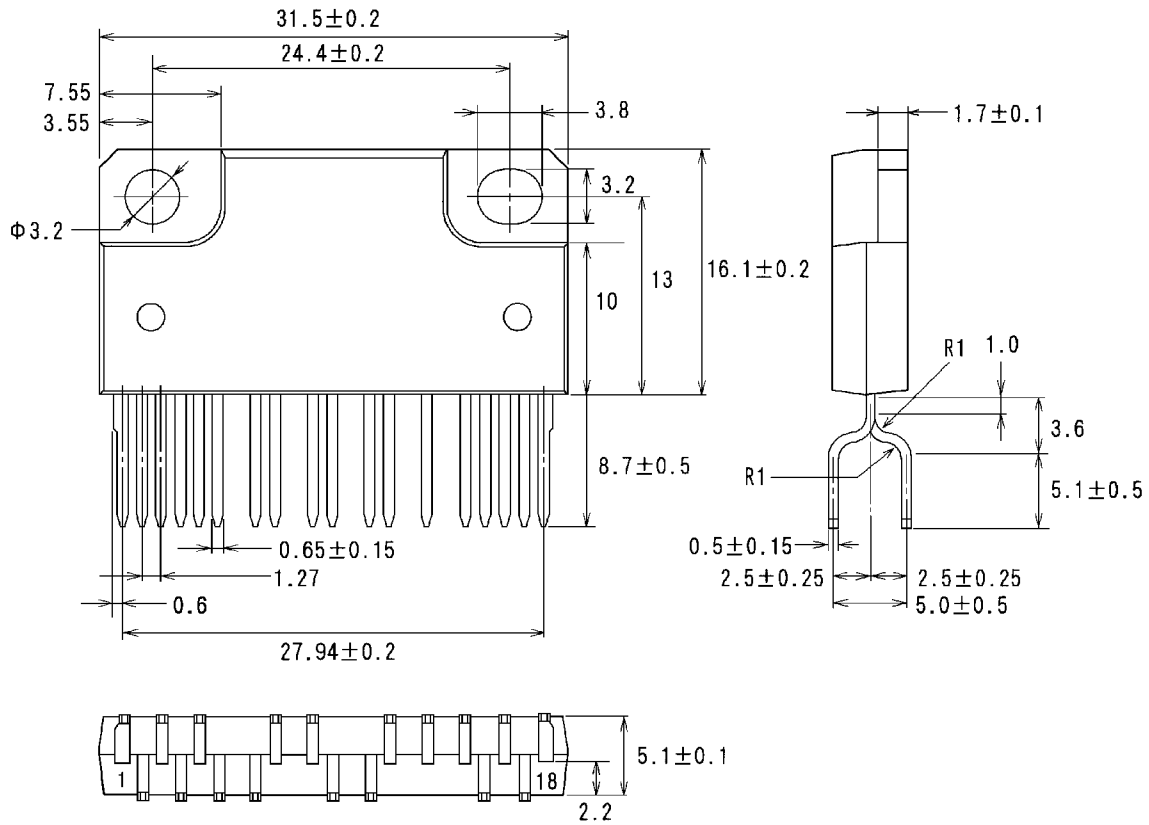

Weight : 5.9 g (Typ.)