

**Descriptions**

- General small signal application
- Switching application

**Features**

- Low collector saturation voltage
- Collector output capacitance
- Complementary pair with 2N3906

**Ordering Information**

Type NO.	Marking	Package Code
2N3904	2N3904	TO-92

**Outline Dimensions**

**unit : mm**

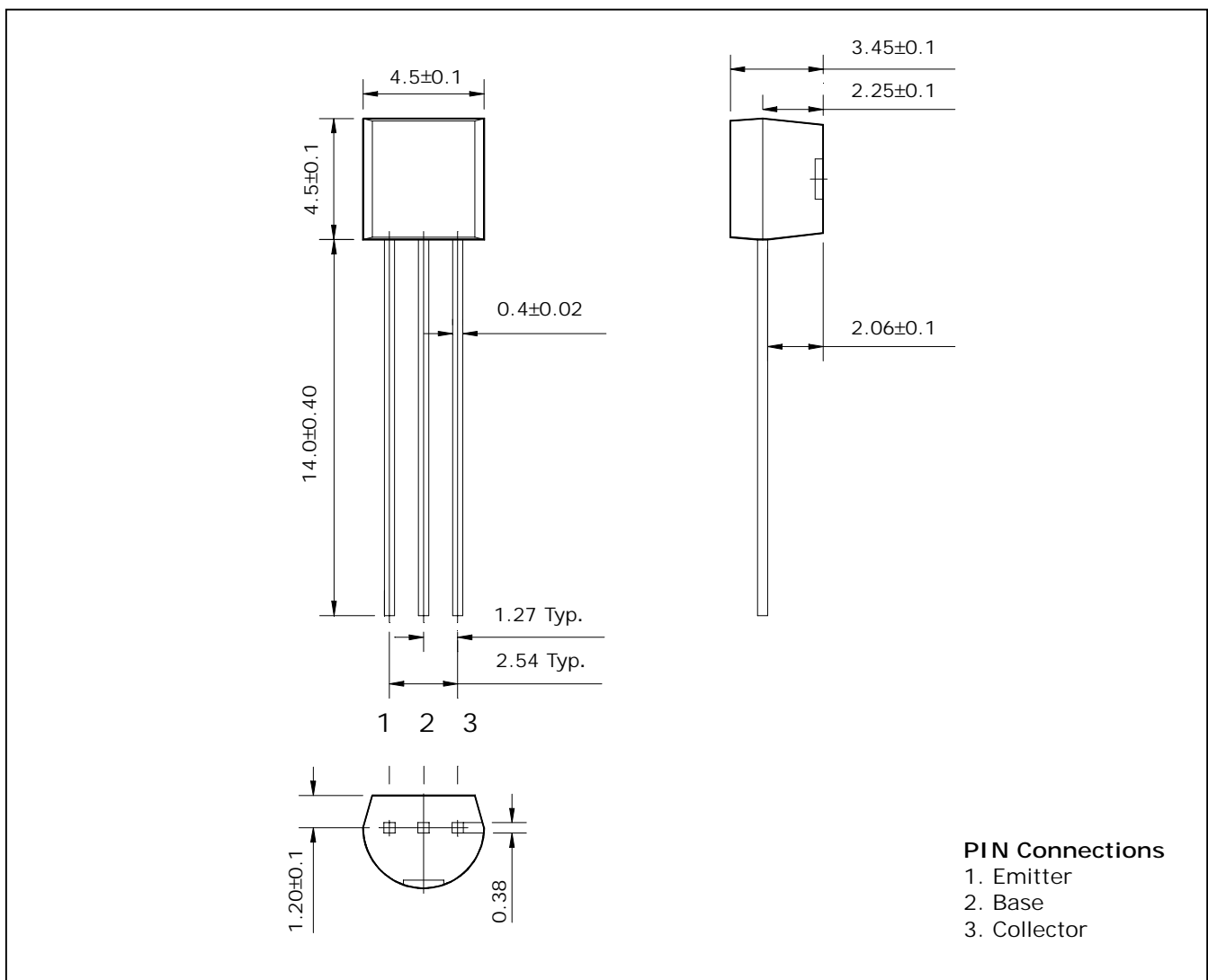

## Absolute maximum ratings

Ta=25°C

Characteristic	Symbol	Ratings	Unit
Collector-Base voltage	$V_{CBO}$	60	V
Collector-Emitter voltage	$V_{CEO}$	40	V
Emitter-base voltage	$V_{EBO}$	6	V
Collector current	$I_C$	200	mA
Collector dissipation	$P_C$	625	mW
Junction temperature	$T_j$	150	°C
Storage temperature range	$T_{stg}$	-55 ~ 150	°C

## Electrical Characteristics

Ta=25°C

Characteristic	Symbol	Test Condition	Min.	Typ.	Max.	Unit
Collector-Base breakdown voltage	$BV_{CBO}$	$I_C=10\mu A, I_E=0$	60	-	-	V
Collector-Emitter breakdown voltage	$BV_{CEO}$	$I_C=1mA, I_B=0$	40	-	-	V
Emitter-Base breakdown voltage	$BV_{EBO}$	$I_E=10\mu A, I_C=0$	6	-	-	V
Collector cut-off current	$I_{CEX}$	$V_{CE}=30V, V_{EB}=3V$	-	-	50	nA
DC current gain	$h_{FE}$	$V_{CE}=1V, I_C=10mA$	100	-	300	-
Collector-Emitter saturation voltage	$V_{CE(sat)}$	$I_C=50mA, I_B=5mA$	-	-	0.3	V
Transition frequency	$f_T$	$V_{CE}=20V, I_C=10mA,$ $f=100MHz$	300	-	-	MHz
Collector output capacitance	$C_{ob}$	$V_{CB}=5V, I_E=0, f=1MHz$	-	-	4	pF
Delay time	$t_d$	$V_{CC}=3V_{dc}, V_{BE(off)}=0.5V_{dc}$	-	-	35	ns
Rise time	$t_r$	$I_C=10mA_{dc}, I_{B1}=1mA_{dc}$	-	-	35	ns
Storage time	$t_s$	$V_{CC}=3V_{dc}, I_C=10mA_{dc}$	-	-	200	ns
Fall Time	$t_f$	$I_{B1}=I_{B2}=1mA_{dc}$	-	-	50	ns

Electrical Characteristic Curves

Fig. 1  $P_C$ - $T_a$

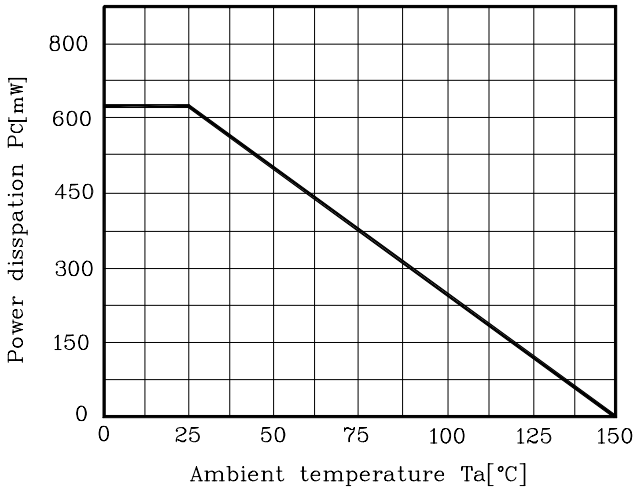

Fig. 2  $h_{FE}$ - $I_C$

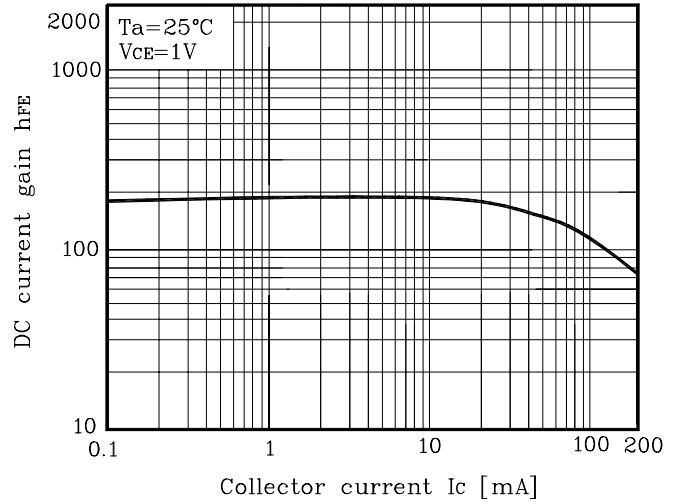

Fig. 3  $V_{CE(sat)}$ - $I_C$

