



STANDARD
MICROSYSTEMS
CORPORATION

USB97CFDC

USB Floppy Disk Controller

FEATURES

- 3.3 Volt, Low Power Operation
- Complete USB Specification 1.1 Compatibility
 - Includes USB Transceiver
 - Based on an Enhanced Version of SMSC's Industry Proven USB97C100 USB Controller
- Complete System Solution Including USB Mass Storage Class Compliant Win98/2000 Driver and Firmware
 - Supports 640K, 720K, 1.44M, 1.2M Windows 98 J, and 1.2M NEC DOS 6.x Formats
 - Supports Both the UFI and SFF8070i Command Sets
 - Supports USB Mass Storage Compliant Bootable Floppy BIOS
 - 4ms Seek Times
 - USB 1.1 Compliance, Including Low Power Device Class SUSPEND Mode Operation and Power Control of Disk Drive
 - Disk Drive Feedback of Readiness Upon Power Re-Application Option
 - Option for Ultra High Performance Using Additional Caching SRAM
 - Support for Floppy Drive Power Control
- Contains SMSC's Industry Proven Floppy Disk Controller
 - Licensed CMOS 765B Floppy Disk Controller
 - Supports Single Normal or Three Mode Floppy Drives
- Supports Vertical Recording Format and High Capacity Drives in User Written Firmware Applications
- Detects All Overrun and Underrun Conditions
- Sophisticated Power Control Circuitry (PCC) Including Multiple Powerdown Modes for Reduced Power Consumption
- Enhanced Digital Data Separator
 - 1 Mbps, 500 Kbps, 300 Kbps, 250 Kbps Data Rates
 - Programmable Precompensation Modes
- Intelligent Auto Power Management
 - <300 μ A SUSPEND Current
 - <75mA Operating Current
- External Program Memory Interface
 - 32K Byte Code Space (Supplied Firmware Requires 16KB Memory)
 - Flash, SRAM, or EPROM Memory
- 4KB Internal Buffer SRAM for High Performance Operation
- Optional External Cache Memory
 - Up to 16K x 8 External SRAM may be Used for Custom Tape/ Drive Applications
- Integrated 14.318 MHz Crystal Driver Circuit
- 100 pin TQFP package (12.0 x 12.0 mm footprint)
 - 25% smaller body size than other 100 pin TQFP packages

ORDERING INFORMATION

Order Number: USB97CFDC-MN
100 Pin TQFP Package

© STANDARD MICROSYSTEMS CORPORATION (SMSC) 2000



80 Arkay Drive
Hauppauge, NY 11788
(631) 435-6000
FAX (631) 273-3123

Standard Microsystems is a registered trademark of Standard Microsystems Corporation, and SMSC is a trademark of Standard Microsystems Corporation. Product names and company names are the trademarks of their respective holders. Circuit diagrams utilizing SMSC products are included as a means of illustrating typical applications; consequently complete information sufficient for construction purposes is not necessarily given. Although the information has been checked and is believed to be accurate, no responsibility is assumed for inaccuracies. SMSC reserves the right to make changes to specifications and product descriptions at any time without notice. Contact your local SMSC sales office to obtain the latest specifications before placing your product order. The provision of this information does not convey to the purchaser of the semiconductor devices described any licenses under the patent rights of SMSC or others. All sales are expressly conditional on your agreement to the terms and conditions of the most recently dated version of SMSC's standard Terms of Sale Agreement dated before the date of your order (the "Terms of Sale Agreement"). The product may contain design defects or errors known as anomalies which may cause the product's functions to deviate from published specifications. Anomaly sheets are available upon request. SMSC products are not designed, intended, authorized or warranted for use in any life support or other application where product failure could cause or contribute to personal injury or severe property damage. Any and all such uses without prior written approval of an Officer of SMSC and further testing and/or modification will be fully at the risk of the customer. Copies of this document or other SMSC literature, as well as the Terms of Sale Agreement, may be obtained by visiting SMSC's website at <http://www.smsc.com>.

SMSC DISCLAIMS AND EXCLUDES ANY AND ALL WARRANTIES, INCLUDING WITHOUT LIMITATION ANY AND ALL IMPLIED WARRANTIES OF MERCHANTABILITY, FITNESS FOR A PARTICULAR PURPOSE, TITLE, AND AGAINST INFRINGEMENT, AND ANY AND ALL WARRANTIES ARISING FROM ANY COURSE OF DEALING OR USAGE OF TRADE.

IN NO EVENT SHALL SMSC BE LIABLE FOR ANY DIRECT, INCIDENTAL, INDIRECT, SPECIAL, PUNITIVE, OR CONSEQUENTIAL DAMAGES, OR FOR LOST DATA, PROFITS, SAVINGS OR REVENUES OF ANY KIND; REGARDLESS OF THE FORM OF ACTION, WHETHER BASED ON CONTRACT, TORT, NEGLIGENCE OF SMSC OR OTHERS, STRICT LIABILITY, BREACH OF WARRANTY, OR OTHERWISE; WHETHER OR NOT ANY REMEDY IS HELD TO HAVE FAILED OF ITS ESSENTIAL PURPOSE; AND WHETHER OR NOT SMSC HAS BEEN ADVISED OF THE POSSIBILITY OF SUCH DAMAGES.

GENERAL DESCRIPTION

The USB97CFDC is an integration of the USB97C102 Enhanced Multi-Endpoint USB Peripheral Controller, without its integrated hub functions, and the SMSC Floppy Disk Controller used in many of its Super IO products, such as the FDC37C869. Special care in the interconnection of the two devices has been taken to assure the lowest possible system current draw (<300 μ A) during SUSPEND mode operation.

Provisions for external Flash Memory up to 32K bytes for program storage is provided.

Although not required for standard floppy operation, provisions for 16K bytes of external buffer SRAM, in addition to that included in the USB97C102 core, is also provided for extended applications, such as tape drives and for other special applications.

Several pins are provided for controlling external power control elements and sensing specialized drive functions.

Note: SMSC has developed and supplies firmware and drivers for this device to implement a standard three mode or dual mode Floppy Disk Drive system with drive power control. If the customer desires to develop his own firmware and/or drivers for this system, he may contact SMSC to obtain a complete engineering specification which details all the internal block functions and register maps of the USB97CFDC to allow custom programs to be written for this device.

TABLE OF CONTENTS

GENERAL DESCRIPTION	3
DESCRIPTION OF PIN FUNCTIONS	5
PIN CONFIGURATION	6
BLOCK DIAGRAM	7
PIN DESCRIPTIONS	7
BUFFER TYPE DESCRIPTIONS	10
BOARD TEST MODE OPERATION	10
DC PARAMETERS	11
AC PARAMETERS	12
USB PARAMETERS	15
USB DC PARAMETERS	15
USB AC PARAMETERS	16
MECHANICAL OUTLINE	18
APPENDIX A:	19
USB97CFDC TYPICAL APPLICATION	19
SMSC PROVIDED SOFTWARE FOR USB97CFDC	20
USB97CFDC REVISIONS	20

DESCRIPTION OF PIN FUNCTIONS

FLOPPY DISK INTERFACE (14 Pins)			
nTRK0	nINDEX	nWRTPRT	nDSKCHG
nRDATA	DRV DEN0	DRV DEN1	nSTEP
nWDATA	nWGATE	nHDSEL	nDIR
nDSO	nMTR0		
USB INTERFACE (4 Pins)			
USB+	USB-	AVDD	AGND
FLASH ROM INTERFACE (26 Pins)			
FD0	FD1	FD2	FD3
FD4	FD5	FD6	FD7
FA0	FA1	FA2	FA3
FA4	FA5	FA6	FA7
FA8	FA9	FA10	FA11
FA12	FA13	FA14	FA15
nFRD	nFCE		
SRAM/IO INTERFACE (24 Pins)			
SD0	SD1	SD2	SD3
SD4	SD5	SD6	SD7
SA0	SA1	SA2	SA3
SA4	SA5	SA6	SA7
SA8	SA9	SA10	SA11
SA12	SA13	nMEMR	nMEMW
MISC (10 Pins)			
nMEMEN	OPTEN	nDRVRDY	nFDPWR
XTAL1/CLKIN	XTAL2	nRESET	nTEST
TST_OUT	nTESTEN		
POWER, GROUNDS, and NO CONNECTS (22 Pins)			

PIN CONFIGURATION

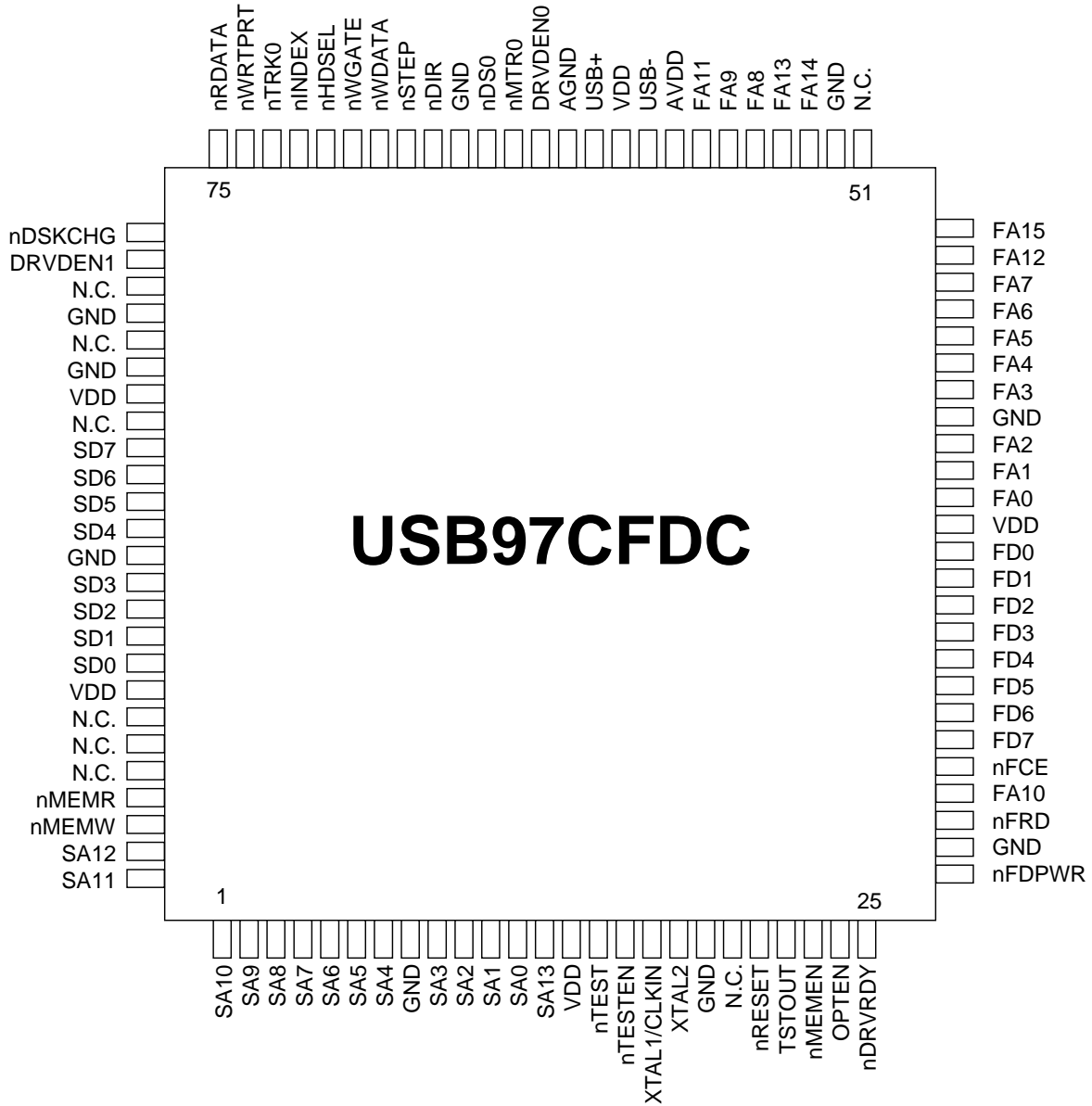

BLOCK DIAGRAM

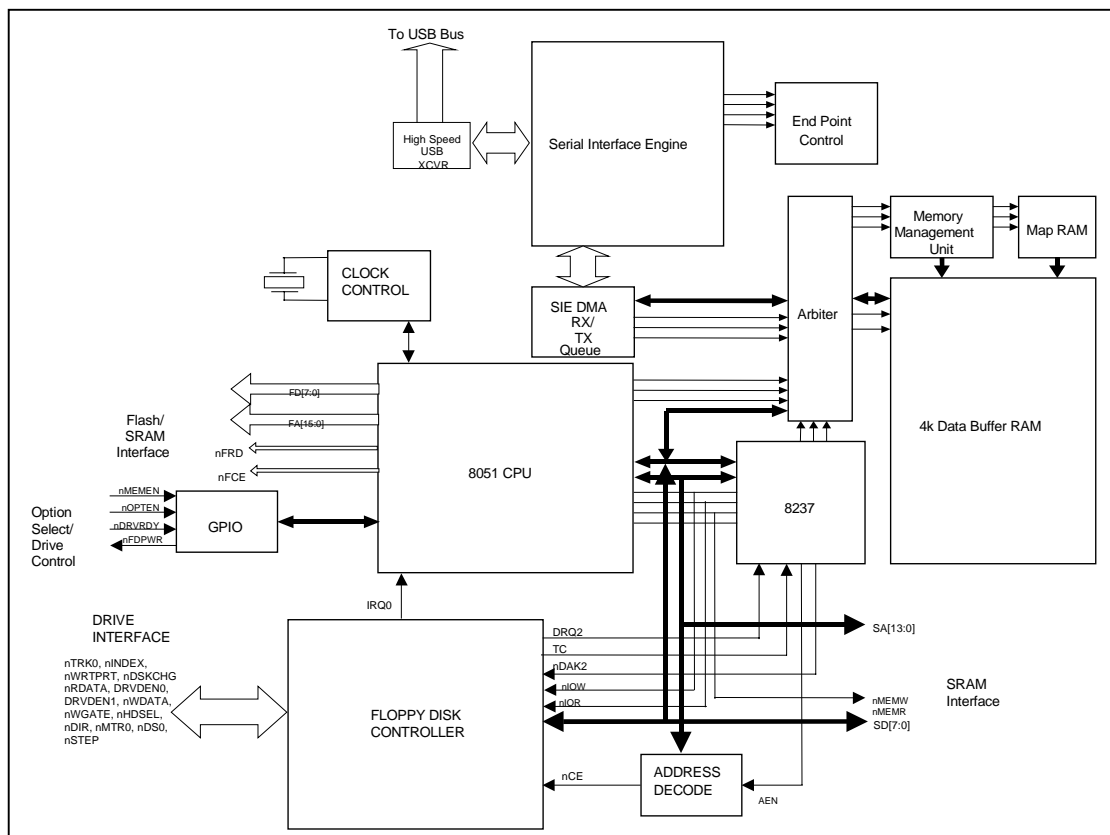

Pin Descriptions

PIN NO.	NAME	SYMBOL	BUFFER TYPE	DESCRIPTION
FLOPPY DISK INTERFACE				
75	Read Disk Data	nRDATA	IS	Raw serial bit stream from the disk drive, low active. Each falling edge represents a flux transition of the encoded data.
69	Write Data	nWDATA	OD12	This active low high current driver provides the encoded data to the disk drive. Each falling edge causes a flux transition on the media.
71	Head Select	nHDSSEL	OD12	This high current output selects the floppy disk side for reading or writing. A logic "1" on this pin means side 0 will be accessed, while a logic "0" means side 1 will be accessed.
67	Direction Control	nDIR	OD12	This high current low active output determines the direction of the head movement. A logic "1" on this pin means outward motion, while a logic "0" means inward motion.
68	Step Pulse	nSTEP	OD12	This active low high current driver issues a low pulse for each track-to-track movement of the head.
76	Disk Change	nDSKCHG	IS	This input senses that the drive door is open or that the diskette has possibly been changed since the last drive selection.

PIN NO.	NAME	SYMBOL	BUFFER TYPE	DESCRIPTION
63	DRV DEN 0	DRV DEN 0	OD12	An active low on this pin indicates a disk drive spindle speed change from 300 RPM to 360 RPM or 1.2M format disks in three mode drives. This pin should be tied to the disk drives spindle speed control input pin.
77	DRV DEN 1	DRV DEN1	OD12	Reserved for future use.
70	Write Gate	nWGATE	OD12	This active low high current driver allows current to flow through the write head. It becomes active just prior to writing to the diskette.
73	Track 0	nTRK0	IS	This active low Schmitt Trigger input senses from the disk drive that the head is positioned over the outermost track.
72	Index	nINDEX	IS	This active low Schmitt Trigger input senses from the disk drive that the head is positioned over the beginning of a track, as marked by an index hole.
74	Write Protect	nWRTPRT	IS	This active low Schmitt Trigger input senses from the disk drive that a disk is write protected. Any write command is ignored.
64	Motor On 0	nMTR0	OD12	This active low open drain output selects motor drive 0.
65	Drive Select 0	nDS0	OD12	This active low open drain output selects drive 0.
USB INTERFACE				
59 61	USB Bus Data	USB- USB+	IO-U	These pins connect to the USB data signals through 33 ohm series resistors. The USB+ line should be pulled up with a 5%, 1.5K ohm resistor to indicate that this is a high speed USB device.
58	USB Transceiver Supply	AVDD		This is the 3.3V supply to the internal USB transceiver.
62	USB Transceiver Ground	AGND		This is the supply ground for the internal USB transceiver.
FLASH INTERFACE				
31-38	Flash Memory Data Bus	FD[7:0]	IO8	These signals are used to transfer data between the internal 8051 and the external FLASH program memory.
50, 53, 54, 49, 57, 29, 56, 55, 48- 44, 42-40,	Flash Memory Address Bus	FA[15:0]	O8	These signals address memory locations within the FLASH memory.
28	Flash Memory Read Strobe	nFRD	O8	Flash ROM Read; active low
30	Flash Memory Chip Select	nFCE	O8	Flash ROM Chip Select; active low
SRAM/IO INTERFACE				
1-7, 9-13, 99,100	SRAM Memory Bus	SA[13:0]	O8	These signals provide the memory address to an external SRAM buffer.
84-87, 89-92	SRAM Memory Data Bus	SD[7:0]	I/O8	These signals are used to transfer data to/from the SRAM Memory.
97	SRAM Memory Read Strobe	nMEMR	O8	Memory read; active low This active low signal indicates that data is to be driven onto the data bus by the SRAM. Data will be latched internal to the chip on the rising edge of this signal
98	SRAM Memory Write Strobe	nMEMW	O8	Memory write; active low This active low signal indicates to the SRAM to load data from the data bus on its rising edge.

PIN NO.	NAME	SYMBOL	BUFFER TYPE	DESCRIPTION
MISCELLANEOUS				
17	Crystal Input/External Clock Input	XTAL1/CLKIN	ICLKx	14.318Mhz Crystal or clock input. This pin can be connected to one terminal of the crystal or can be connected to an external 14.318Mhz clock when a crystal is not used.
18	Crystal Output	XTAL2	OCLKx	14.318Mhz Crystal This is the other terminal of the crystal, or left open when an external clock source is used to drive XTAL1/CLKIN. It may not be used to drive any external circuitry other than the crystal circuit.
23	SRAM Enable	nMEMEN	O24	An active low signal is output on this pin to enable the optional external SRAM for extended FDC write and read caching for ultra high performance applications.
24	Option Enable	OPTEN	I	Current firmware utilizes this input pin for detecting the media density switch of the drive. Various firmware options are available for different polarities of this signal. Contact factory for available firmware options. If this pin is not driven by the drive, it should be tied low.
25	Drive Ready	nDRVRDY	I	An active low signal on this pin from the floppy disk drive, after DS0 goes active, indicates that the system may activate MTR0. If the drive does not supply this signal, this pin should be tied low.
26	Drive Power	nFDPWR	OD24	This active low signal is intended to activate an external power switch, either in the drive or on the system board, to supply power to the floppy disk drive. It is active whenever the USB97CFDC is not in SUSPEND mode.
21	RESET input	nRESET	IS	This active low signal is used by the system to reset the chip. The active low pulse should be at least 100ns wide.
22	Test output	TSTOUT	O8	This signal is used for testing the chip via an internal XNOR chain. User should normally leave it unconnected.
15	Test input	nTEST	I	This signal is a manufacturing test pin. It should be tied to VDD for normal operation.
16	Test Enable	nTESTEN	I	This active low signal places the device into board test mode using the XNOR chain. For normal operation this pin should be tied high. See Board Test Mode Operation on page 10
POWER, GROUND, AND NO CONNECTS				
14, 39, 60, 82, 93		VDD		+3.3V power
8, 19, 27, 43, 52, 66, 79, 81, 88		GND		Ground Reference
20, 51, 78, 80, 83, 94-96		NC		No Connect. These pins should not be connected externally.

BUFFER TYPE DESCRIPTIONS

Table 1 - USB97CFDC Buffer Type Descriptions

BUFFER	DESCRIPTION
I	Input
IS	Input with Schmitt trigger
O8	Output with 8mA drive
I/O8	Input/output with 8mA drive
OD12	Open drain....12mA sink
O24	Output with 24mA drive
OD24	Open drain....24mA sink
ICLKx	XTAL clock input
OCLKx	XTAL clock output
I/O-U	See Table 6.

BOARD TEST MODE OPERATION

By driving the nTESTEN pin low, the device will be placed into a special test mode to allow verification of attachment of the device to the circuit board. Every pin except the TSTOUT, XTAL2, and the power and ground pins become an input to an XNOR chain, as shown below, to allow continuity to be tested on the board. This test should individually toggle the state of the trace connected to the pin being examined for continuity, and the TSTOUT pin monitored for toggle of state. If no toggle occurs, either the pin under test is discontinuous, or the TSTOUT pin is not connected on the board

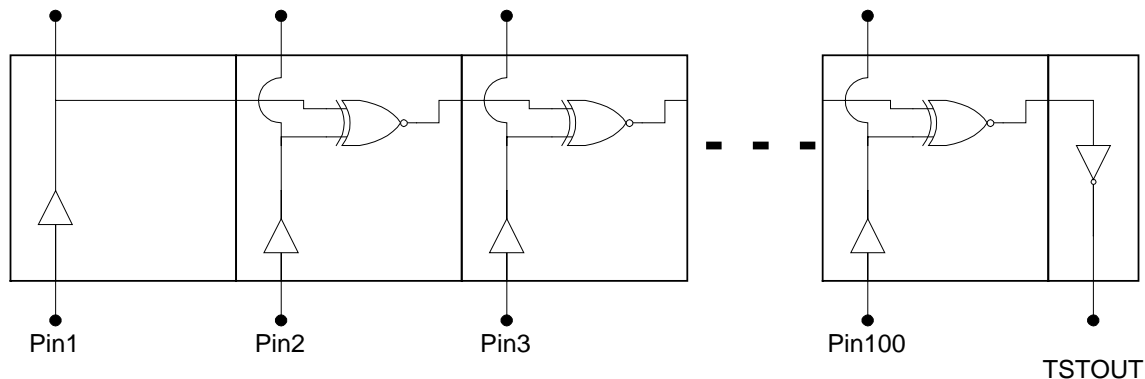

DC PARAMETERS

MAXIMUM GUARANTEED RATINGS

Operating Temperature Range	0°C to +70°C
Storage Temperature Range	-55° to +150°C
Lead Temperature Range (soldering, 10 seconds).....	+325°C
Positive Voltage on any pin, with respect to Ground (Note 1).....	V _{cc} +0.3V
Negative Voltage on any pin, with respect to Ground	-0.3V
Maximum V _{cc}	+3.6V

Note 1: Maximum voltage on all I type Inputs and the IS inputs, OD12 and OD24 outputs for floppy disk drive interface is 5.25V

*Stresses above the specified parameters could cause permanent damage to the device. This is a stress rating only and functional operation of the device at any other condition above those indicated in the operation sections of this specification is not implied.

Note 2: When powering this device from laboratory or system power supplies, it is important that the Absolute Maximum Ratings not be exceeded or device failure can result. Some power supplies exhibit voltage spikes on their outputs when the AC power is switched on or off. In addition, voltage transients on the AC power line may appear on the DC output. When this possibility exists, it is suggested that a clamp circuit be used.

DC ELECTRICAL CHARACTERISTICS (T_A = 0°C - 70°C, V_{cc} = +3.3 V ± 10%)

PARAMETER	SYMBOL	MIN	TYP	MAX	UNITS	COMMENTS
I Type Input Buffer						
Low Input Level	V _{ILI}			0.8	V	TTL Levels
High Input Level	V _{IHI}	2.0			V	
ICLK Input Buffer						
Low Input Level	V _{ILCK}			0.4	V	
High Input Level	V _{IHCK}	2.2			V	
Input Leakage (All I and IS buffers)						
Low Input Leakage	I _{IL}	-10		+10	uA	V _{IN} = 0
High Input Leakage	I _{IH}	-10		+10	uA	V _{IN} = V _{CC}
O8 Type Buffer						
Low Output Level	V _{OL}			0.4	V	I _{OL} = 8 mA
High Output Level	V _{OH}	2.4			V	I _{OH} = -4 mA
Output Leakage	I _{OL}	-10		+10	UA	V _{IN} = 0 to V _{CC} (Note 1)
I/O8 Type Buffer						
Low Output Level	V _{OL}			0.4	V	I _{OL} = 8mA
High Output Level	V _{OH}	2.4			V	I _{OH} = -4mA
Output Leakage	I _{OL}	-10		+10	μA	V _{IN} = 0 to V _{cc} (Note 1)
OD12 Type Buffer						
Low Output Level	V _{OL}			0.4	V	I _{OL} = 12mA
Output Leakage	I _{OL}	-10		+10	μA	V _{IN} = 0 to V _{cc} (Note 1)

PARAMETER	SYMBOL	MIN	TYP	MAX	UNITS	COMMENTS
O24 Type Buffer						
Low Output Level	V_{OL}			0.4	V	IOL = 24mA
High Output Level	V_{OH}	2.4			V	IOH = -12mA
Output Leakage	I_{OL}	-10		+10	μ A	VIN = 0 to Vcc (Note 1)
OD24 Type Buffer						
Low Output Level	V_{OL}			0.4	V	IOL = 24mA
Output Leakage	I_{OL}	-10		+10	μ A	VIN = 0 to Vcc (Note 1)
IO-U						
Note 2						
Supply Current Active	I_{CC}		30	75	MA	All outputs open.
Supply Current Standby	I_{CSBU}		120	300	μ A	

Note 1: Output leakage is measured with the current pins in high impedance.

Note 2: See Appendix A for USB DC electrical characteristics.

CAPACITANCE $T_A = 25^\circ\text{C}$; $f_c = 1\text{MHz}$; $V_{CC} = 3.3\text{V}$

PARAMETER	SYMBOL	LIMITS			UNIT	TEST CONDITION
		MIN	TYP	MAX		
Clock Input Capacitance	C_{IN}			20	pF	All pins except USB pins (and pins under test tied to AC ground)
Input Capacitance	C_{IN}			10	pF	
Output Capacitance	C_{OUT}			20	pF	

AC PARAMETERS

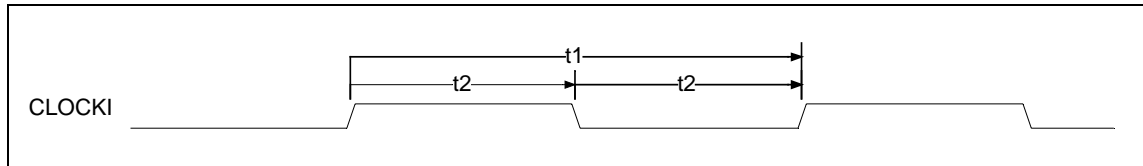

FIGURE 1 - INPUT CLOCK TIMING

Table 2 – Input Clock Timing Parameters

NAME	DESCRIPTION	MIN	TYP	MAX	UNITS
t_1	Clock Cycle Time for 14.318MHz		69.84		ns
t_2	Clock High Time/Low Time for 24MHz	41.9/ 27.9		27.9/ 41.9	ns
t_r, t_f	Clock Rise Time/Fall Time (not shown)			5	ns

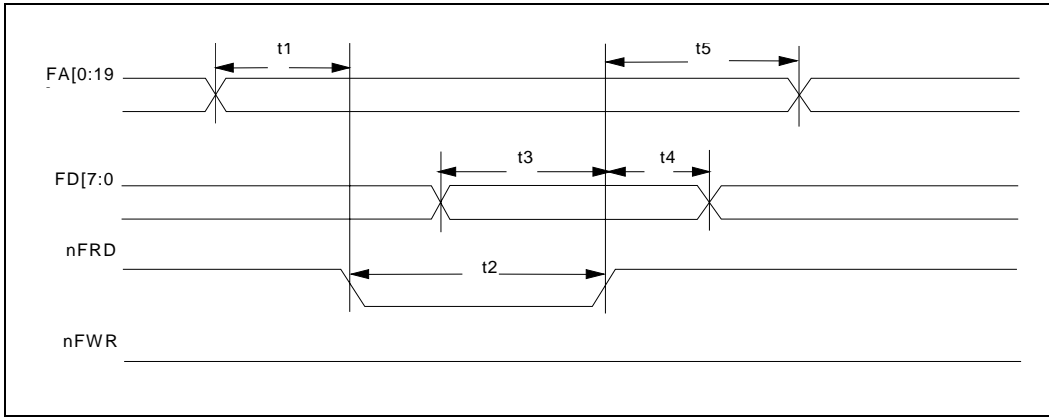

FIGURE 2 – FLASH READ TIMING

Table 3 – Flash Read Timing

NAME	PARAMETER	MIN	TYP	MAX	UNITS
t1	FA[14:0] Address setup time to nFRD asserted	40			ns
t2	nFRD pulse width	110			ns
t3	FD[7:0] Data setup time to nFRD de-asserted	30			ns
t4	FD[7:0] Data hold time from nFRD de-asserted	0			ns
t5	FA[14:0] Address hold time from nFRD de-asserted	35			ns

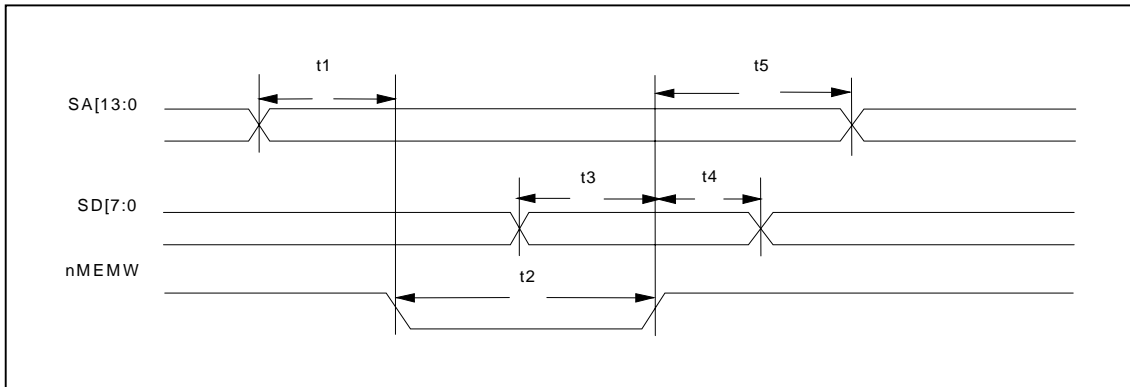

FIGURE 3 – SRAM MEMORY WRITE TIMING

Table 4 – SRAM Memory Write Timing

NAME	PARAMETER	MIN	TYP	MAX	UNITS
t1	SA[19:0] valid before nMEMWR asserted	10			ns
t2	nMEMWR pulse width	100			ns
t3	SD[7:0] Data setup time to nMEMWR de-asserted	50			ns
t4	SD[7:0] Data hold time from nMEMWR de-asserted	10			ns
t5	nMEMWR de-asserted to SA[13:0] invalid	10			ns

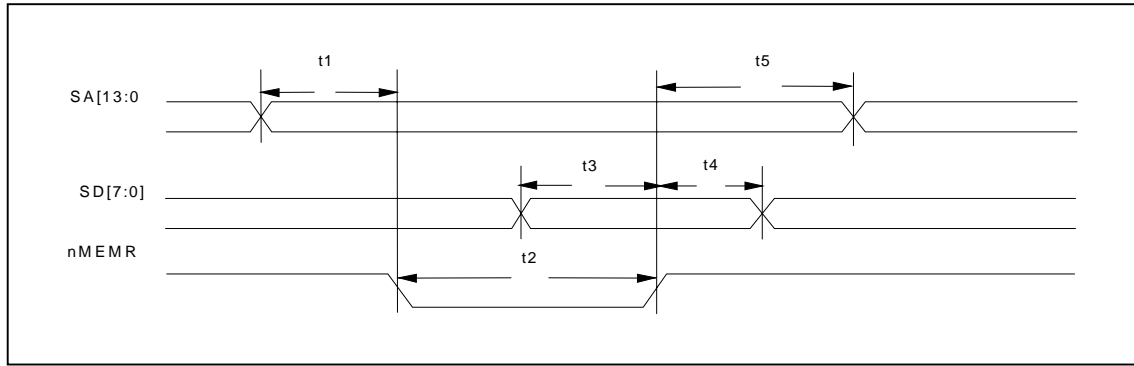
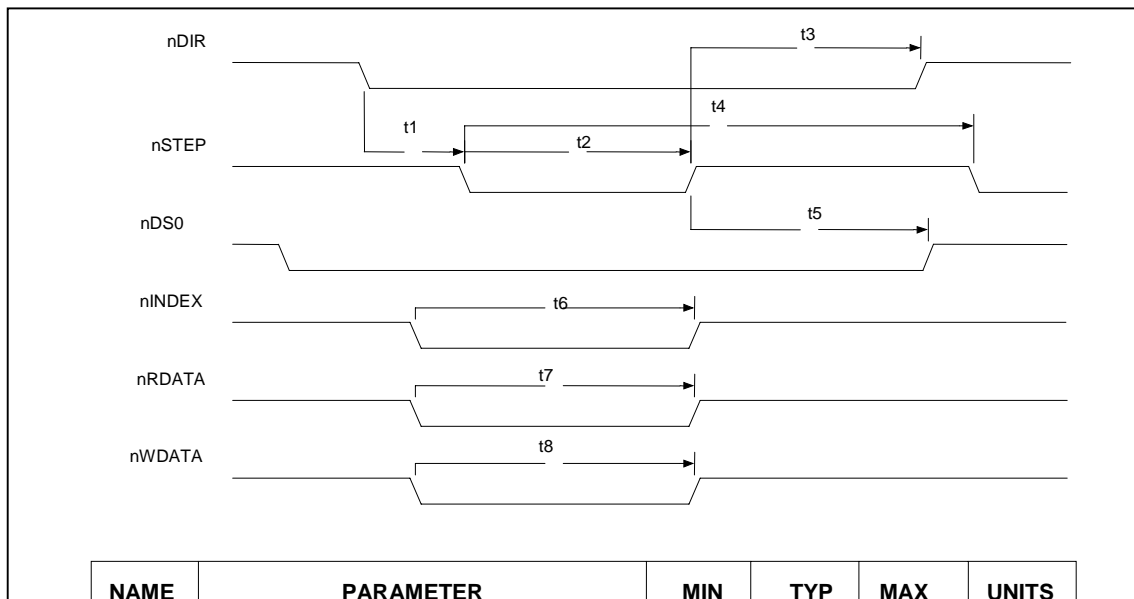

FIGURE 4 - SRAM MEMORY READ TIMING

Table 5 – SRAM Memory Read Timing

NAME	PARAMETER	MIN	TYP	MAX	UNITS
t1	SA[19:0] valid before nMEMRD asserted	10			ns
t2	nMEMRD pulse width	100			ns
t3	SD[7:0] Data setup time to nMEMRD de-asserted	50			ns
t4	SD[7:0] Data hold time from nMEMRD de-asserted	20			ns
t5	nMEMRD de-asserted to SA [13:0] invalid	10			ns



NAME	PARAMETER	MIN	TYP	MAX	UNITS
t1	nDIR Set Up to nSTEP Low		4		X*
t2	nSTEP Active Time Low		24		X*
t3	nDIR Hold Time After nSTEP		96		X*
t4	nSTEP Cycle Time		132		X*
t5	nDS0-1 Hold Time from nSTEP Low		20		X*
t6	nINDEX Pulse Width		2		X*
t7	nRDATA Active Time Low		40		ns
t8	nWDATA Write Data Width Low		.5		Y*

*X specifies one MCLK period and Y specifies one WCLK period.
MCLK = 16x Data Rate (at 500 Kbp/s MCLK = 8 MHz)
WCLK = 2x Data Rate (at 500 Kbp/s WCLK = 1 MHz)

FIGURE 5 - DISK DRIVE TIMING

USB PARAMETERS

The following tables and diagrams were obtained from the USB specification

USB DC PARAMETERS

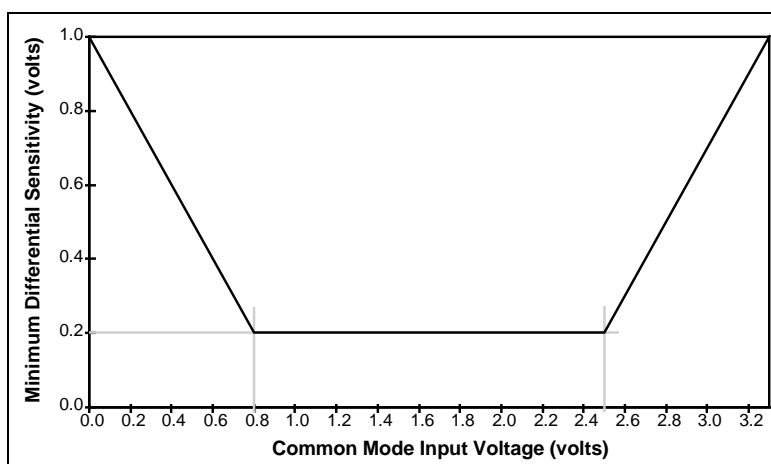

FIGURE 6 - DIFFERENTIAL INPUT SENSITIVITY OVER ENTIRE COMMON MODE RANGE

Table 6 - DC Electrical Characteristics

PARAMETER	SYMBOL	CONDITIONS (NOTE 1, 2)	MIN	TYP	MAX	UNIT
Supply Voltage						
Powered (Host or Hub) Port	VBUS		4.4		5.25	V
Supply Current						
Function	ICC	Note 4			100	mA
Un-configured Function (in)	ICCNIT	Note 5			100	uA
Suspend Device	ICCS				100	uA
Leakage Current						
Hi-Z State Data Line Leakage	ILO	0 V < VIN < 3.3 V	-10		10	uA
Input Levels						
Differential Input Sensitivity	VDI	[(D+) - (D-)] , and FIGURE 6	0.2			V
Differential Common Mode Range	VCM	Includes VDI range	0.8		2.5	V
Single Ended Receiver Threshold	VSE		0.8		2.0	V
Output Levels						
Static Output Low	VOL	RL of 1.5 KΩ to 3.6 V			0.3 (3)	V
Static Output High	VOH	RL of 15 KΩ to GND	2.8		3.6 (3)	V
Capacitance						
Transceiver Capacitance	CIN	Pin to GND			20	pF
Terminals						
Bus Pull-up Resistor on Root Port	RPU	(1.5 KΩ +/- 5%)	1.425		1.575	kΩ
Bus Pull-down Resistor on Downstream Port	RPD	(15 KΩ +/- 5%)	14.25		15.75	kΩ

Note 1: All voltages are measured from the local ground potential, unless otherwise specified.

Note 2: All timing use a capacitive load (CL) to ground of 50pF, unless otherwise specified.

Note 3: This is relative to VUSBIN.

Note 4: This is dependent on block configuration set by software.

Note 5: When the internal ring oscillator and waiting for first setup packet.

USB AC PARAMETERS

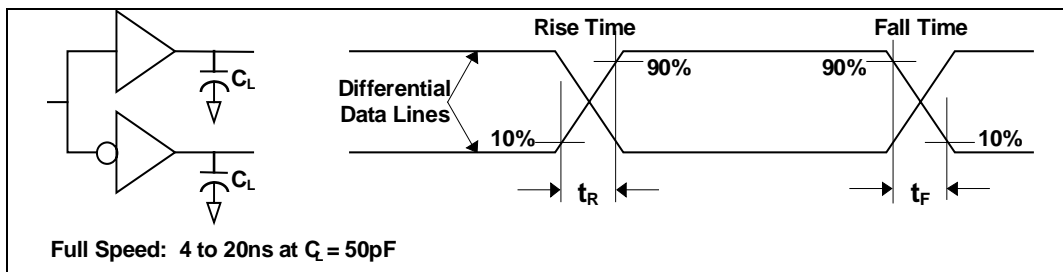

FIGURE 7 - DATA SIGNAL RISE AND FALL TIME

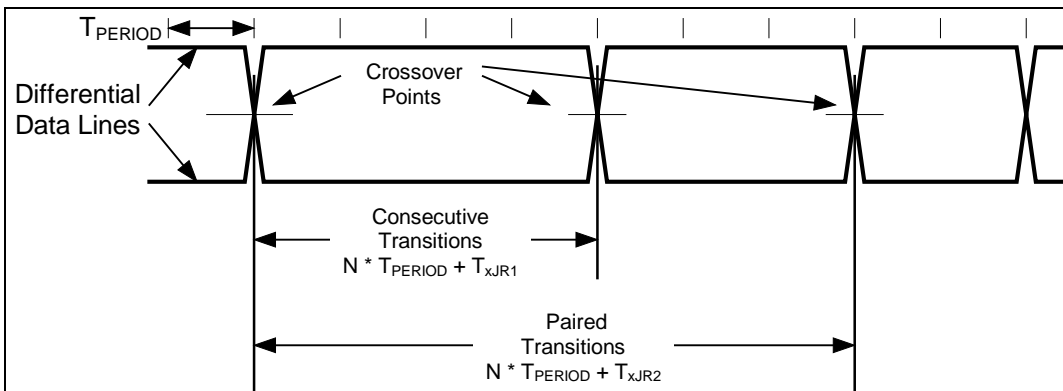

FIGURE 8 - DIFFERENTIAL DATA JITTER

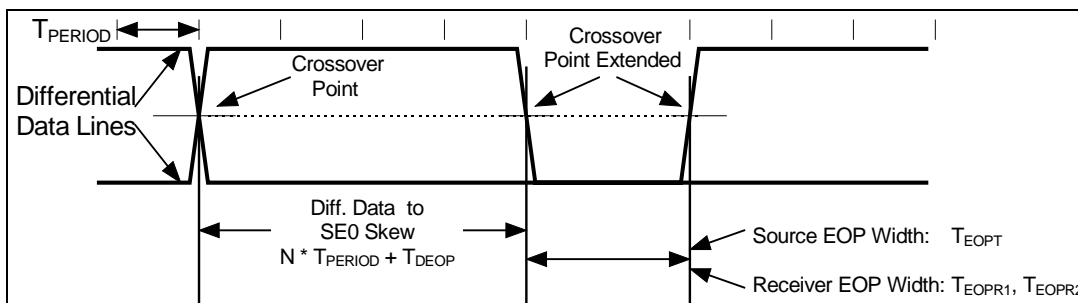

FIGURE 9 - DIFFERENTIAL TO EOP TRANSITION SKEW AND EOP WIDTH

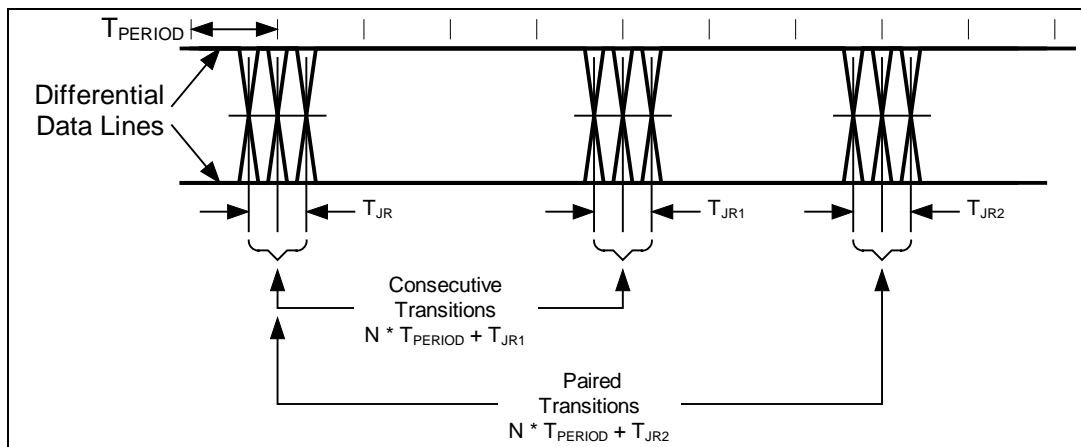

FIGURE 10 - RECEIVER JITTER TOLERANCE

Table 2 - Full Speed (12Mbps) Source Electrical Characteristics

PARAMETER	SYM	CONDITIONS (NOTE 1, 2, 3)	MIN	TYP	MAX	UNIT
Driver Characteristics						
Transition Time:		Note 4,5 and FIGURE 7				
Rise Time	TR	CL = 50 pF	4		20	ns
Fall Time	TF	CL = 50 pF	4		20	ns
Rise/Fall Time Matching	TRFM	(TR/TF)	90		110	%
Output Signal Crossover Voltage	VCRS		1.3		2.0	V
Drive Output Resistance	ZDRV	Steady State Drive	28		43	Ω
Data Source Timing						
Full Speed Data Rate	TDRATE	Ave. Bit Rate (12 Mb/s +/- 0.25%) Note 8	11.95		12.03	Mbs
Frame Interval	TFRAME	1.0 ms +/- 0.05%	0.999 5		1.0005	ms
Source Differential Driver Jitter		Note 6, 7 and FIGURE 8				
To next Transition For Paired Transitions	TDJ1 TDJ2		-3.5 -4.0		3.5 4.0	ns ns
Source EOP Width	TEOPT	Note 7 and FIGURE 9	160		175	ns
Differential to EOP transition Skew	TDEOP	Note 7 and FIGURE 9	-2		5	ns
Receiver Data Jitter Tolerance		Note 7 and FIGURE 10				
To next Transition For Paired Transitions	TJR1 TJR2		-18.5 -9		18.5 9.0	ns ns
EOP Width at receiver		Note 7 and FIGURE 9				
Must reject as EOP						ns
Must Accept	TEOPR1 TEOPR2		40 82			ns ns
Cable Impedance and Timing						
Cable Impedance (Full Speed)	ZO	(45 Ω +/- 15%)	38.75		51.75	Ω
Cable Delay (One Way)	TCBL				30	ns

Note 1: All voltages are measured from the local ground potential, unless otherwise specified.

Note 2: All timing use a capacitive load (CL) to ground of 50pF, unless otherwise specified.

Note 3: Full speed timings have a 1.5KΩ pull-up to 2.8 V on the D+ data line.

Note 4: Measured from 10% to 90% of the data signals.

Note 5: The rising and falling edges should be smoothly transiting (monotonic).

Note 6: Timing differences between the differential data signals.

Note 7: Measured at crossover point of differential data signals.

Note 8: These are relative to the 14.318 MHz crystal.

MECHANICAL OUTLINE

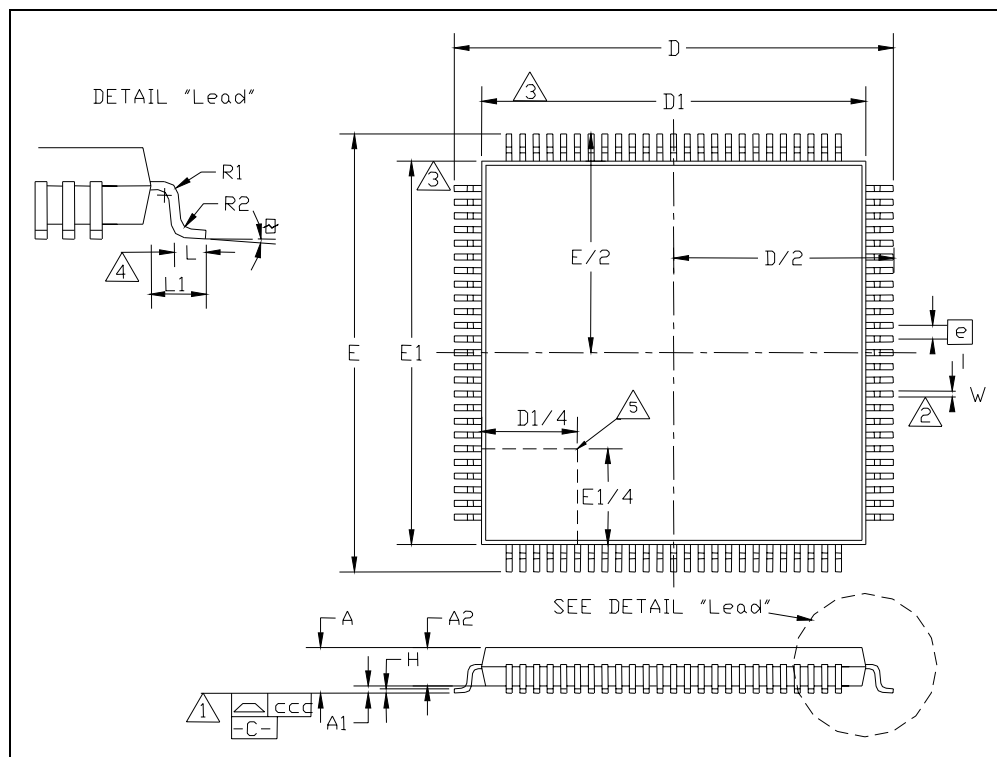

FIGURE 11 - 100 PIN TQFP PACKAGE

	MIN	NOMINAL	MAX	REMARK
A	~	~	1.60	Overall Package Height
A1	0.05	~	0.15	Standoff
A2	1.35	1.40	1.45	Body Thickness
D	13.80	14.00	14.20	X Span
D/2	6.90	7.00	7.10	$\frac{1}{2}$ X Span Measure from Centerline
D1	11.80	12.00	12.20	X body Size
E	13.80	14.00	14.20	Y Span
E/2	6.90	7.00	7.10	$\frac{1}{2}$ Y Span Measure from Centerline
E1	11.80	12.00	12.20	Y body Size
H	0.09	~	0.20	Lead Frame Thickness
L	0.45	0.60	0.75	Lead Foot Length from Centerline
L1	~	1.00	~	Lead Length
e	0.40 Basic			Lead Pitch
	0°	3.5°	7°	Lead Foot Angle
W	0.13	0.16	0.23	Lead Width
R1	0.08	~	~	Lead Shoulder Radius
R2	0.08	~	0.20	Lead Foot Radius
ccc	~	~	0.08	Coplanarity

Note 1: Controlling Unit: millimeter

Note 2: Minimum space between protrusion and an adjacent lead is .007 mm.

Note 3: Package body dimensions D1 and E1 do not include the mold protrusion. Maximum mold protrusion is 0.25 mm

Note 5: Details of pin 1 identifier are optional but must be located within the zone indicated.

APPENDIX A:

USB97CFDC TYPICAL APPLICATION

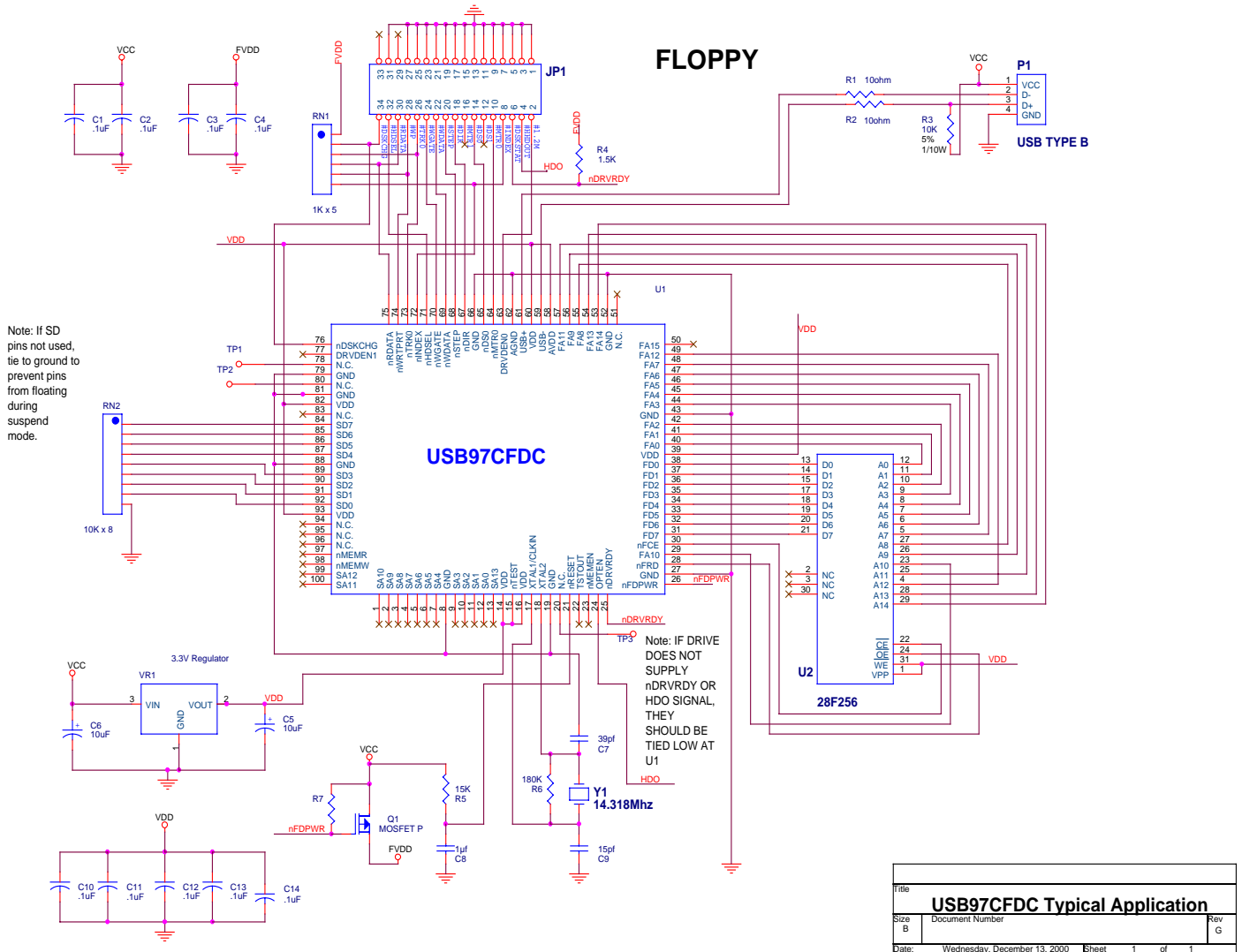

Title			USB97CFDC Typical Application		
Size	Document Number				Rev
B					G
Date:	Wednesday, December 13, 2000	Sheet	1	of	1

SMSC PROVIDED SOFTWARE FOR USB97CFDC

SMSC provides the following for the USB97CFDC:

- I. Program firmware with the following features:
 - (a) Supports 640K, 720K, 1.44M, 1.2M Windows J, 1.2M NEC DOS 6.x formats.
 - (b) Supports USB Mass Storage Class compliant drivers from Apple and Microsoft as well as SMSC's Windows 98 driver.
 - (c) Supports USB Mass Storage compliant bootable floppy BIOS.
 - (d) 4ms Seek times.
 - (e) USB 1.1 compliance, including low power device class SUSPEND mode operation and power control of disk drive.
 - (f) Disk drive feedback of readiness upon power re-application (optional).
 - (g) Option for using drive media density sense output (HDO#) pin to prevent attempts to format 2DD disks as 2HD.
- II. USB Mass Storage Class compliant driver for Windows 98.

USB97CFDC REVISIONS

PAGE(S)	SECTION/FIGURE/ENTRY	CORRECTION	DATE REVISED
19	USB97CFDC TYPICAL APPLICATION	Updated schematic	12/15/00
19	USB97CFDC TYPICAL APPLICATION	Updated schematic	11/01/00