

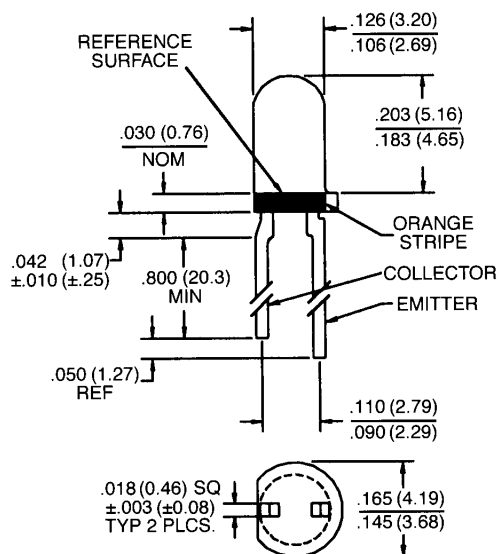

PLASTIC SILICON PHOTODARLINGTON

QSC133

PACKAGE DIMENSIONS



ST2143

NOTES:

1. DIMENSIONS ARE IN INCHES (mm).
2. TOLERANCE IS ±.010 (.25) UNLESS OTHERWISE SPECIFIED.
3. FLAT DENOTES COLLECTOR.

DESCRIPTION

The QSC133 is a silicon photodarlington encapsulated in an infrared transparent, black T-1 package.

FEATURES

- Steel lead frames for improved reliability in solder mounting.
- Good optical-to-mechanical alignment.
- Plastic package is infrared transparent and tinted to attenuate visible light.
- Mechanically and spectrally matched to the QECXXX LED.
- Black plastic body allows easy recognition from LED.



PLASTIC SILICON PHOTODARLINGTON

ABSOLUTE MAXIMUM RATINGS ($T_A = 25^\circ\text{C}$ Unless Otherwise Specified)	
Storage Temperature	-40°C to $+100^\circ\text{C}$
Operating Temperature	-40°C to $+100^\circ\text{C}$
Soldering:	
Lead Temperature (Iron)	240°C for 5 sec. ^(2,3,4,5)
Lead Temperature (Flow)	260°C for 10 sec. ^(2,3,5)
Collector-Emitter Breakdown Voltage	30 Volts
Emitter-Collector Breakdown Voltage	5.0 Volts
Power Dissipation	100 mW ⁽¹⁾

ELECTRICAL CHARACTERISTICS ($T_A = 25^\circ\text{C}$ Unless Otherwise Specified) (All measurements made under pulse conditions.)						
PARAMETER	SYMBOL	MIN.	TYP.	MAX.	UNITS	TEST CONDITIONS
Collector-Emitter Breakdown	BV_{CEO}	30	—	—	V	$I_C = 1\text{ mA}$
Emitter-Collector Breakdown	BV_{ECO}	5.0	—	—	V	$I_E = 100\ \mu\text{A}$
Collector-Emitter Leakage	I_{CEO}	—	—	100	nA	$V_{CE} = 10\text{ V}$
Reception Angle at $\frac{1}{2}$ Sensitivity	θ	—	± 8	—	Degrees	
On-State Collector Current	$I_{C(ON)}$	8.0	—	—	mA	$E_e = 0.25\text{ mW/cm}^2$, $V_{CE} = 5\text{ V}$ ⁽⁶⁾
Collector-Emitter Saturation Voltage	$V_{CE(SAT)}$	—	—	1.0	V	$I_C = 0.4\text{ mA}$, $E_e = 0.25\text{ mW/cm}^2$ ⁽⁶⁾
Rise Time	t_r	—	20	—	μS	$I_C = .15\text{ mA}$, $V_{CC} = 5\text{ V}$, $R_L = 100\ \Omega$
Fall Time	t_f	—	50	—	μS	$I_C = .15\text{ mA}$, $V_{CC} = 5\text{ V}$, $R_L = 100\ \Omega$

NOTES
<ol style="list-style-type: none"> 1. Derate power dissipation linearly 1.33 mW/$^\circ\text{C}$ above 25°C. 2. RMA flux is recommended. 3. Methanol or Isopropyl alcohols are recommended as cleaning agents. 4. Soldering iron tip $\frac{1}{16}$" (1.6 mm) minimum from housing. 5. As long as leads are not under any stress or spring tension. 6. Light source is an AlGaAs LED emitting light at a peak wavelength of 880 nm.