

**D<sup>3</sup>PAK Package Outline.**  
Dimensions in mm (inches)

**N-CHANNEL  
ENHANCEMENT MODE  
HIGH VOLTAGE  
POWER MOSFETS**

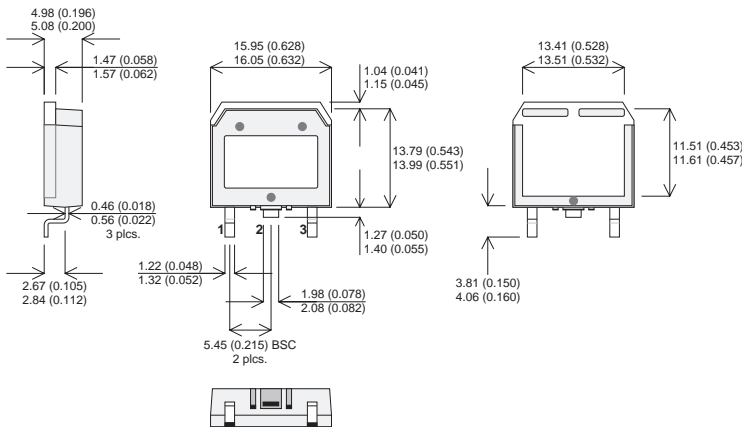

**V<sub>DSS</sub>            600V**  
**I<sub>D(cont)</sub>        16A**  
**R<sub>DS(on)</sub>       0.400Ω**

**Pin 1 – Gate            Pin 2 – Drain            Pin 3 – Source**  
**Heatsink is Drain.**

- **Faster Switching**
- **Lower Leakage**
- **100% Avalanche Tested**
- **Surface Mount D<sup>3</sup>PAK Package**

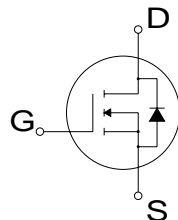

StarMOS is a new generation of high voltage N-Channel enhancement mode power MOSFETs. This new technology minimises the JFET effect, increases packing density and reduces the on-resistance. StarMOS also achieves faster switching speeds through optimised gate layout.

**ABSOLUTE MAXIMUM RATINGS** (T<sub>case</sub> = 25°C unless otherwise stated)

V <sub>DSS</sub>	Drain – Source Voltage	600	V
I <sub>D</sub>	Continuous Drain Current	16	A
I <sub>DM</sub>	Pulsed Drain Current <sup>1</sup>	64	A
V <sub>GS</sub>	Gate – Source Voltage	±30	V
V <sub>GSM</sub>	Gate – Source Voltage Transient	±40	
P <sub>D</sub>	Total Power Dissipation @ T <sub>case</sub> = 25°C	250	W
	Derate Linearly	2	W/°C
T <sub>J</sub> , T <sub>STG</sub>	Operating and Storage Junction Temperature Range	-55 to 150	°C
T <sub>L</sub>	Lead Temperature : 0.063" from Case for 10 Sec.	300	
I <sub>AR</sub>	Avalanche Current <sup>1</sup> (Repetitive and Non-Repetitive)	16	A
E <sub>AR</sub>	Repetitive Avalanche Energy <sup>1</sup>	30	mJ
E <sub>AS</sub>	Single Pulse Avalanche Energy <sup>2</sup>	960	

1) Repetitive Rating: Pulse Width limited by maximum junction temperature.  
2) Starting T<sub>J</sub> = 25°C, L = 7.5mH, R<sub>G</sub> = 25Ω, Peak I<sub>L</sub> = 16A

**STATIC ELECTRICAL RATINGS** ( $T_{case} = 25^{\circ}C$  unless otherwise stated)

	Characteristic	Test Conditions	Min.	Typ.	Max.	Unit
$BV_{DSS}$	Drain – Source Breakdown Voltage	$V_{GS} = 0V, I_D = 250\mu A$	600			V
$I_{DSS}$	Zero Gate Voltage Drain Current ( $V_{GS} = 0V$ )	$V_{DS} = V_{DSS}$			25	$\mu A$
		$V_{DS} = 0.8V_{DSS}, T_C = 125^{\circ}C$			250	
$I_{GSS}$	Gate – Source Leakage Current	$V_{GS} = \pm 30V, V_{DS} = 0V$			$\pm 100$	nA
$V_{GS(TH)}$	Gate Threshold Voltage	$V_{DS} = V_{GS}, I_D = 1.0mA$	2		4	V
$I_{D(ON)}$	On State Drain Current <sup>2</sup>	$V_{DS} > I_{D(ON)} \times R_{DS(ON)}$ Max $V_{GS} = 10V$	16			A
$R_{DS(ON)}$	Drain – Source On State Resistance <sup>2</sup>	$V_{GS} = 10V, I_D = 0.5 I_D [Cont.]$			0.40	$\Omega$

**DYNAMIC CHARACTERISTICS**

	Characteristic	Test Conditions	Min.	Typ.	Max.	Unit
$C_{iss}$	Input Capacitance	$V_{GS} = 0V$		2600		pF
$C_{oss}$	Output Capacitance	$V_{DS} = 25V$		315		
$C_{rss}$	Reverse Transfer Capacitance	$f = 1MHz$		115		
$Q_g$	Total Gate Charge <sup>3</sup>	$V_{GS} = 10V$		115		nC
$Q_{gs}$	Gate – Source Charge	$V_{DD} = 0.5 V_{DSS}$		11		
$Q_{gd}$	Gate – Drain (“Miller”) Charge	$I_D = I_D [Cont.] @ 25^{\circ}C$		46		
$t_{d(on)}$	Turn-on Delay Time	$V_{GS} = 15V$		14		ns
$t_r$	Rise Time	$V_{DD} = 0.5 V_{DSS}$		14		
$t_{d(off)}$	Turn-off Delay Time	$I_D = I_D [Cont.] @ 25^{\circ}C$		47		
$t_f$	Fall Time	$R_G = 1.6\Omega$		7		

**SOURCE – DRAIN DIODE RATINGS AND CHARACTERISTICS**

	Characteristic	Test Conditions	Min.	Typ.	Max.	Unit
$I_S$	Continuous Source Current	(Body Diode)			16	A
$I_{SM}$	Pulsed Source Current <sup>1</sup>	(Body Diode)			64	
$V_{SD}$	Diode Forward Voltage <sup>2</sup>	$V_{GS} = 0V, I_S = -I_D [Cont.]$			1.3	V
$t_{rr}$	Reverse Recovery Time	$I_S = -I_D [Cont.], di_S / dt = 100A/\mu s$		370		ns
$Q_{rr}$	Reverse Recovery Charge	$I_S = -I_D [Cont.], di_S / dt = 100A/\mu s$		5.2		$\mu C$

**THERMAL CHARACTERISTICS**

	Characteristic	Min.	Typ.	Max.	Unit
$R_{\theta JC}$	Junction to Case			0.50	$^{\circ}C/W$
$R_{\theta JA}$	Junction to Ambient			40	

1) Repetitive Rating: Pulse Width limited by maximum junction temperature.

2) Pulse Test: Pulse Width < 380 $\mu s$ , Duty Cycle < 2%

3) See MIL-STD-750 Method 3471



CAUTION — Electrostatic Sensitive Devices. Anti-Static Procedures Must Be Followed.