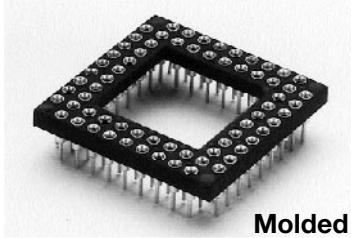
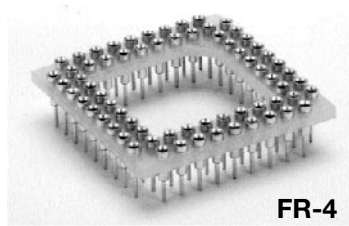
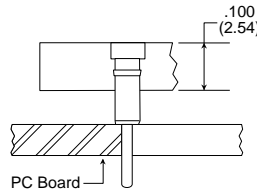
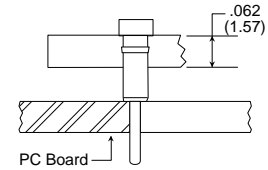

## Molded & FR-4 Low Insertion Force PGA Sockets

**Molded**

**FR-4**

### Features:

- As low as 1 oz.(28.34 g) average insertion force per pin.
- Multiple finger contacts for reliability.
- Over 500 PGA footprints available.
- Closed bottom terminal for 100% anti-wicking of solder.
- Tapered entry for ease of insertion.
- To fit .100" (2.54 mm) grid.
- Easily customized to fit your application.

### Terminals and Contacts:

Terminal: Brass - Copper Alloy (C36000)  
ASTM-B-16

Contact: Beryllium Copper (C17200)  
ASTM-B-194

### Solder Preform:

63% Tin, 37% Lead

### Plating:

Terminal: Gold over Nickel or  
Tin-Lead over Nickel

Contact: Gold over Nickel or  
Tin-Lead over Nickel

Gold per MIL-G-45204

Tin-Lead per MIL-P-81728

Nickel per QQ-N-290

### Body Material:

**CS/CIS** - Glass Filled Thermoplastic Polyester (P.B.T.), U.L. Rated 94V-O, -60°C to 140°C (-76°F to 284°F)

**HCS/HCIS** - High Temp. Glass Filled Thermoplastic (P.P.S.), U.L. Rated 94V-O, -60°C to 260°C (-76°F to 500°F)

**FS/FIS** - FR-4 Fiberglass Epoxy Board, U.L. Rated 94V-O, Index 140°C (284°F)

### How To Order

#### 1 oz. (28.34 g) Average Insertion Force Sockets

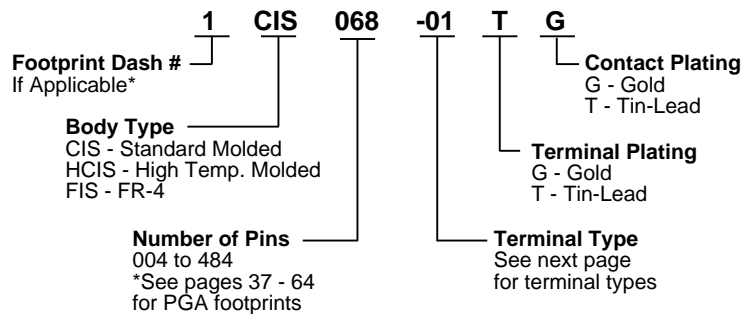

### How To Order

#### 2.5 oz. (70.85 g) Average Insertion Force Sockets

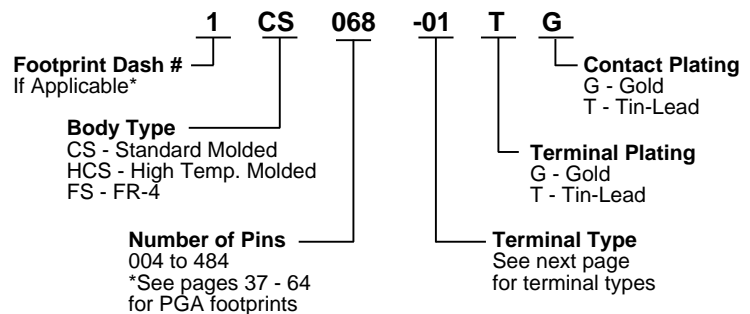

### Sealant Options

**RTV Sealed**

To order: Add RTV to end of part #

Note: RTV not available with HCS or HCIS Insulators

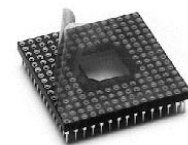
**Tape Sealed**

To order: Add 3M to end of part #

## Terminals for Molded & FR-4 Low Insertion Force PGA Sockets

### Standard Quick Turn Terminal

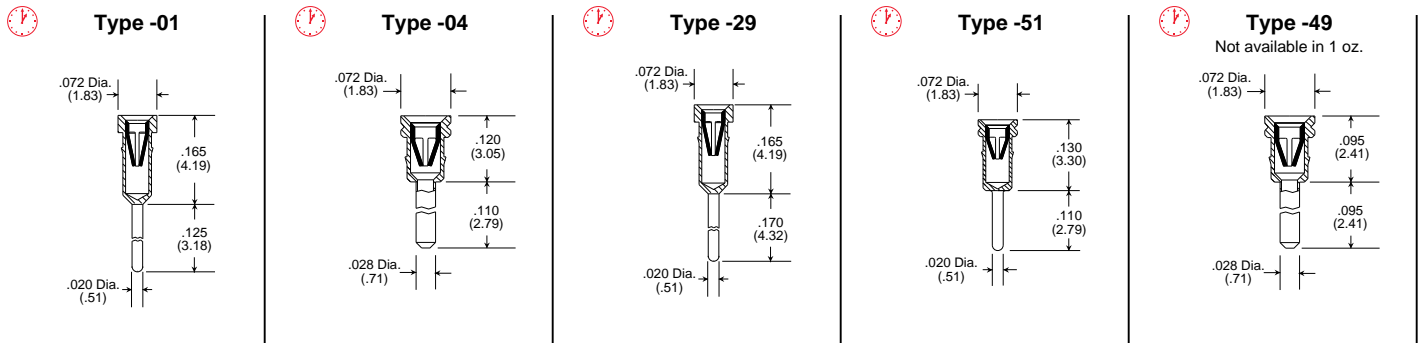

Quick turn delivery available on standard terminal types.

Additional terminal types available. See terminal section for detailed terminal information.

## Solder Preform PGA Sockets - Intrusive Reflow Application

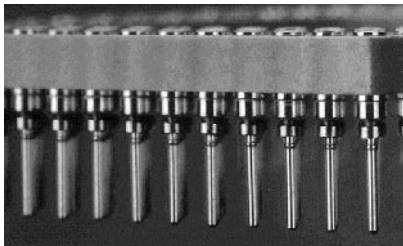

### Features:

- Combines the labor of socket loading and solder application into one operation.
- Eliminates the use of solder paste and screening operation.
- Eliminates solder bridges and/or solder shorts due to excess solder.
- Ensures a reliable solder joint with controlled solder volume.
- Ideal for surface mount and mixed technology applications.
- For custom solder preform terminal applications consult factory.
- See previous page for material specifications and how to order information.

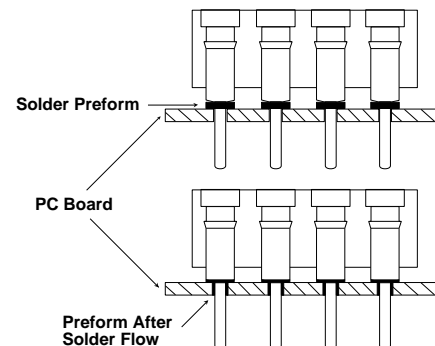

### Solder Preform Terminals

