

DUAL-POLARITY TRACKING REGULATORS

DESCRIPTION

The SG1568/SG1468 is a dual-polarity tracking regulator designed to provide balanced positive and negative output voltages at currents to 100mA. The device is set internally for $\pm 15V$ outputs but a single external adjustment can be used to change both outputs simultaneously from 9V to 20V. Input voltages up to $\pm 30V$ can be used and there is provision for adjustable current limiting.

FEATURES

- Outputs balanced to within 1% (SG1568)
- Line and load regulation of 0.06%
- 1% maximum output variation due to temperature changes
- Standby current drain of 3.0mA
- Remote sensing provisions

HIGH RELIABILITY FEATURES - SG1568

- ◆ Available to MIL-STD-883
- ◆ SG level "S" processing available

BLOCK DIAGRAM

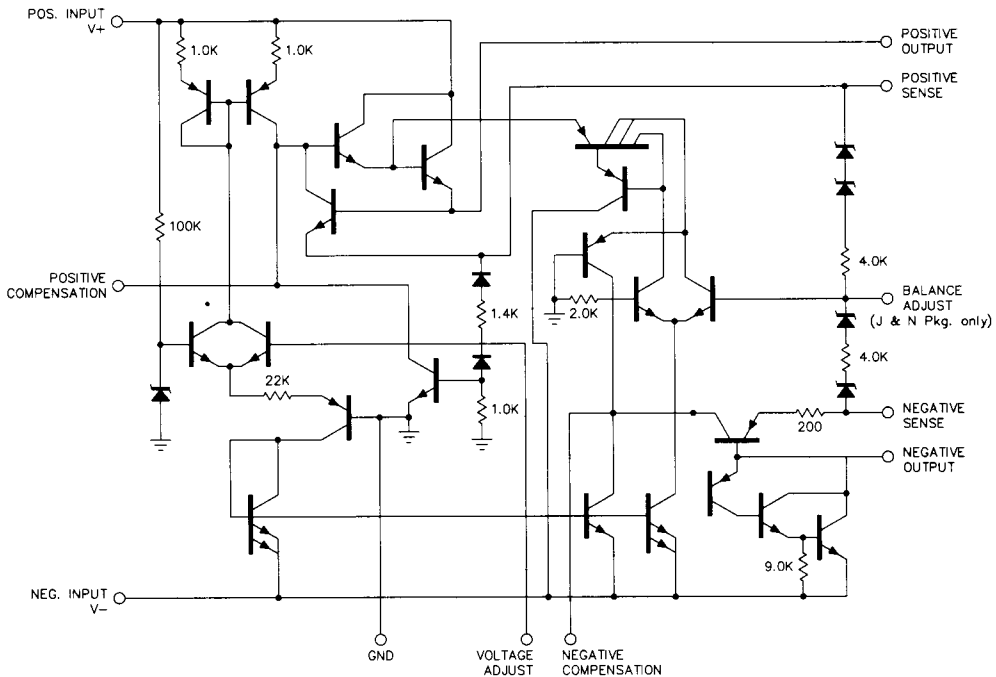

ABSOLUTE MAXIMUM RATINGS (Note 1)

Input Voltage 30V
 Peak Load Current 100mA
 Minimum Short-Circuit Resistance 4.0Ω

Operating Junction Temperature
 Hermetic (J, T, R-Packages) 150°C
 Plastic (N-Package) 150°C
 Storage Temperature Range -65°C to 150°C
 Lead Temperature (Soldering, 10 Seconds) 300°C

Note 1. Exceeding these ratings could cause damage to the device.

THERMAL DERATING CURVES

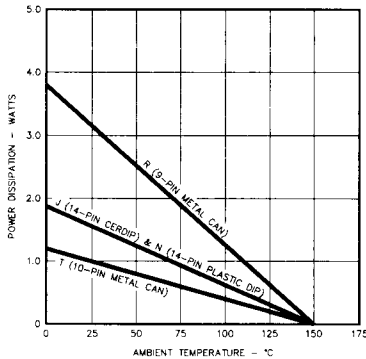

MAXIMUM POWER DISSIPATION vs AMBIENT TEMPERATURE

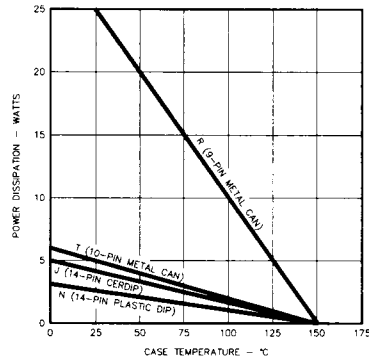

MAXIMUM POWER DISSIPATION vs CASE TEMPERATURE

RECOMMENDED OPERATING CONDITIONS (Note 2)

Input Voltage 7.0V to 30V

Operating Ambient Temperature

SG1568 -55°C to 125°C

SG1468 0°C to 70°C

Note 2. Range over which the device is functional.

ELECTRICAL SPECIFICATIONS

(Unless otherwise specified, these specifications apply for the operating ambient temperature $T_A = 25^\circ\text{C}$, $V_{CC} = 20\text{V}$, $V_{EE} = 20\text{V}$, $C_1 = C_2 = 1500\text{pF}$, $C_3 = C_4 = 1.0\mu\text{F}$, $+I_L = -I_L = 0$, and $R_{SC} = 4.0\Omega$ for both positive and negative inputs. Low duty cycle pulse testing techniques are used which maintains junction and case temperatures equal to the ambient temperature.)

Parameter	Test Conditions	SG1568			SG1468			Units
		Min.	Typ.	Max.	Min.	Typ.	Max.	
Output Voltage		14.5		15.5	14.5		15.5	V
Input Voltage				30			30	V
Input-Output Voltage Differential				2.0			2.0	V
Output Voltage Balance				±150			±300	mV
Line Regulation Voltage				10			10	mV
Load Regulation Voltage (Note 3)	$V_{IN} = 18\text{V to }30\text{V}$			20			20	mV
	$T_A = T_{MIN} \text{ to } T_{MAX}$			10			10	mV
	$I_L = 0 \text{ to } 50 \text{ mA}$			30			30	mV
	$T_A = T_{MIN} \text{ to } T_{MAX}$			20	9.0		20	V
Output Voltage Range		9.0		20	9.0		20	V
Ripple Rejection	$f = 120\text{Hz}$		75			75		dB
Output Voltage Temperature Stability (Note 4)	$T_A = T_{MIN} \text{ to } T_{MAX}$			1.0		1.0		%
Short Circuit Current Limit	$R_{SC} = 10\Omega$		60			60		mA
Output Noise Voltage	$\text{BW} = 100\text{Hz to }10\text{kHz}$		100			100		μV(rms)
Positive Standby Current	$V_{IN} = 30\text{V}$			4.0		4.0		mA
Negative Standby Current	$V_{IN} = -30\text{V}$			3.0		3.0		mA
Long Term Stability			0.2		0.2			%/Khr

Note 3. Applies for constant junction temperature.

Note 4. This parameter, although guaranteed, is not tested in production.

APPLICATION INFORMATION

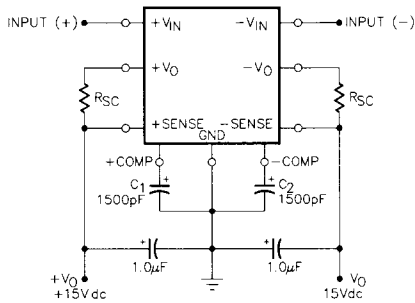

C1 and C2 should be located as close to the device as possible. A 0.1μF ceramic capacitor may be required on the input lines if the device is located an appreciable distance from the rectifier filter capacitors.

C3 and C4 may be increased to improve load transient response and to reduce the output noise voltage. At low temperature operation it may be necessary to bypass C4 with a 0.1μF ceramic disc capacitor.

FIGURE 1 - BASIC 50mA REGULATOR

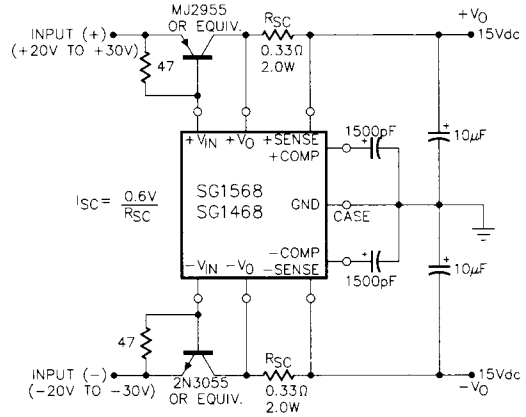

FIGURE 2 - 1.5A REGULATOR
SHORT CIRCUIT PROTECTED, WITH PROPER HEATSINKING

CONNECTION DIAGRAMS & ORDERING INFORMATION (See Notes Below)

Package	Part No.	Ambient Temperature Range	Connection Diagram
14-PIN CERAMIC DIP J - PACKAGE	SG1568J/883B SG1568J SG1468J	-55°C to 125°C -55°C to 125°C 0°C to 70°C	
14-PIN PLASTIC DIP N - PACKAGE	SG1468N	0°C to 70°C	
9-PIN METAL CAN R - PACKAGE	SG1568R/883B SG1568R SG1568R SG1468R	-55°C to 125°C -55°C to 125°C 0°C to 70°C 0°C to 70°C	<p>NOTE: CASE IS GROUND</p>
10-PIN METAL CAN T - PACKAGE	SG1568T/883B SG1568T SG1568T SG1468T	-55°C to 125°C -55°C to 125°C 0°C to 70°C 0°C to 70°C	

1. Contact factory for JAN and DESC product availability.
2. All packages are viewed from the top.