

### General Description

The AAT3120 is a low noise, constant frequency charge pump DC/DC converter that uses fractional (1.5X) conversion to improve efficiency for white LED applications. The device can be used to produce eight current levels up to 20mA per channel for up to three channels. 1X load switch mode is also built-in to improve efficiency at low current settings. Low external parts count (two 1 $\mu$ F flying capacitors and two small 1 $\mu$ F capacitors at V<sub>IN</sub> and OUT) makes the AAT3120 ideally suited for small battery-powered applications.

AnalogicTech's S<sup>2</sup>Cwire™ (Simple Serial Control™) serial digital input is used to enable, disable, and set current for each LED at eight different levels.

The AAT3120 has a thermal management system to protect the device in the event of a short-circuit condition at the output pin. Built-in soft-start circuitry prevents excessive inrush current during start-up. A high charge pump switching frequency enables the use of very small external capacitors. A low current shutdown feature disconnects the load from V<sub>IN</sub> and reduces quiescent current to less than 1 $\mu$ A. The AAT3120 is available in the very small Pb-free 12-pin TSOPJW package.

### Typical Application

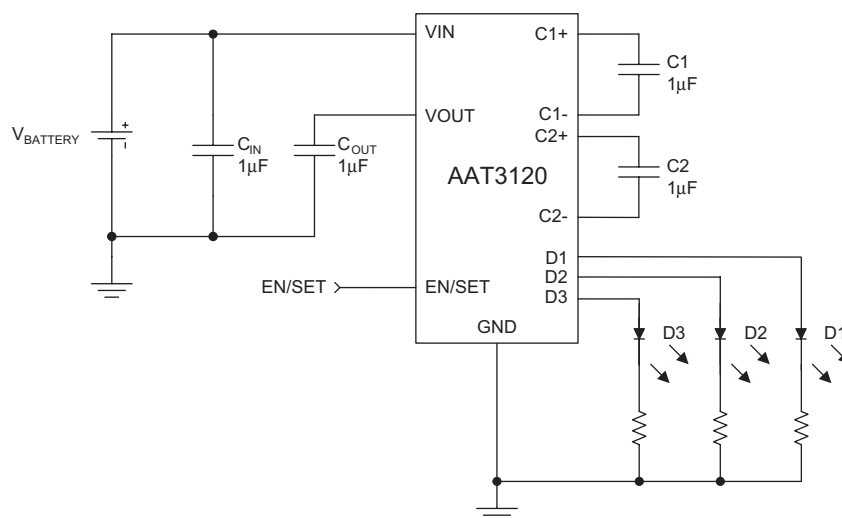

### Features

- V<sub>IN</sub> Range: 2.7V to 5.5V
- Fractional Charge Pump Mode
- Drives Low-V<sub>F</sub> and High-V<sub>F</sub> Type LEDs
- Up to Three LED Outputs
  - Single Wire Programming
  - Eight Regulated Current Settings
  - Max 20mA per Channel
- Low Noise Constant Frequency Operation
- No Inductors
- 1MHz Switching Frequency
- Small Application Circuit
- Automatic Soft-Start
- I<sub>Q</sub> < 1 $\mu$ A in Shutdown
- 12-Pin TSOPJW Package

### Applications

- Color (RGB) Lighting
- Programmable Current Source
- White LED Backlighting
- White Photo Flash for DSCs

## Pin Descriptions

Pin #	Symbol	Function
1	C2+	Flying capacitor 2 positive terminal. Connect a 1 $\mu$ F capacitor between C2+ and C2-.
2	OUT	Charge pump output. Requires 1 $\mu$ F capacitor connected between this pin and ground.
3	C1-	Flying capacitor 1 negative terminal.
4	C1+	Flying capacitor 1 positive terminal. Connect a 1 $\mu$ F capacitor between C1+ and C1-.
5	N/C	No connection.
6	D3	Current source output #3.
7	D2	Current source output #2.
8	D1	Current source output #1.
9	EN/SET	Control pin.
10	IN	Input power supply. Requires 1 $\mu$ F capacitor connected between this pin and ground.
11	GND	Ground.
12	C2-	Flying capacitor 2 negative terminal.

## Pin Configuration

**TSOPJW-12**  
(Top View)

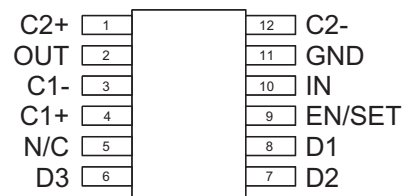

### Absolute Maximum Ratings<sup>1</sup>

$T_A = 25^\circ\text{C}$ , unless otherwise noted.

Symbol	Description	Value	Units
$V_{IN}$	Input Voltage	-0.3 to 6	V
$V_{OUT}$	Charge Pump Output	-0.3 to 6	V
$V_{EN/SET}$	FB or EN/SET to GND Voltage	-0.3 to 6	V
$V_{EN/SET(MAX)}$	Maximum EN/SET to Input Voltage	0.3	V
$I_{OUT}^2$	Maximum DC Output Current	150	mA
$T_J$	Operating Junction Temperature Range	-40 to 150	$^\circ\text{C}$
$T_{LEAD}$	Maximum Soldering Temperature (at leads, 10 sec)	300	$^\circ\text{C}$

### Thermal Information<sup>3</sup>

Symbol	Description	Value	Units
$\theta_{JA}$	Thermal Resistance	160	$^\circ\text{C}/\text{W}$
$P_D$	Maximum Power Dissipation <sup>4</sup>	0.625	W

1. Stresses above those listed in Absolute Maximum Ratings may cause permanent damage to the device. Functional operation at conditions other than the operating conditions specified is not implied. Only one Absolute Maximum Rating should be applied at any one time.
2. Based on long-term current density limitation.
3. Mounted on an FR4 board.
4. Derate 6.25mW/ $^\circ\text{C}$  above 25 $^\circ\text{C}$ .

### Electrical Characteristics<sup>1</sup>

$C_{IN} = C_{OUT} = C_1 = C_2 = 1.0\mu\text{F}$ ;  $T_A = -40^\circ\text{C}$  to  $+85^\circ\text{C}$ , unless otherwise noted. Typical values are  $T_A = 25^\circ\text{C}$ ,  $V_{IN} = 3.5\text{V}$ .

Symbol	Description	Conditions	Min	Typ	Max	Units
Input Power Supply						
$V_{IN}$	Operation Range		2.7		5.5	V
$I_{CC}$	Operating Current	$3.0\text{V} \leq V_{IN} \leq 5.5\text{V}$ , Active, No Load Current		1.8	3.0	mA
$I_{SHDN}$	Shutdown Current	$EN = 0$			1.0	$\mu\text{A}$
$I_{DX}$	Output Current	$3.0 \leq V_{IN} \leq 5.5$	18	20	22	mA
$I_{(D-Match)}$	Current Matching Between Any Two Outputs	$VD1:D3 = 3.6$ , $V_{IN} = 3.5\text{V}$		0.5		%
Charge Pump Section						
$T_{SS}$	Soft-Start Time			200		$\mu\text{s}$
$F_{CLK}$	Clock Frequency			1000		kHz
EN/SET						
$V_{EN(L)}$	Enable Threshold Low	$2.7\text{V} \leq V_{IN} \leq 5.5\text{V}$			0.4	V
$V_{EN(H)}$	Enable Threshold High	$2.7\text{V} \leq V_{IN} \leq 5.5\text{V}$	1.4			V
$T_{EN/SET LO}$	EN/SET Low Time		0.3		75	$\mu\text{s}$
$T_{EN/SET HI}$	Minimum EN/SET High Time			50		ns
$T_{OFF}$	EN/SET Off Timeout				500	$\mu\text{s}$
Input Current	EN/SET Input Leakage		-1		1	$\mu\text{A}$

1. The AAT3120 is guaranteed to meet performance specifications over the  $-40^\circ\text{C}$  to  $+85^\circ\text{C}$  operating temperature range and is assured by design, characterization, and correlation with statistical process controls.

### Typical Characteristics

Turn-On to Full-Scale Load Switch

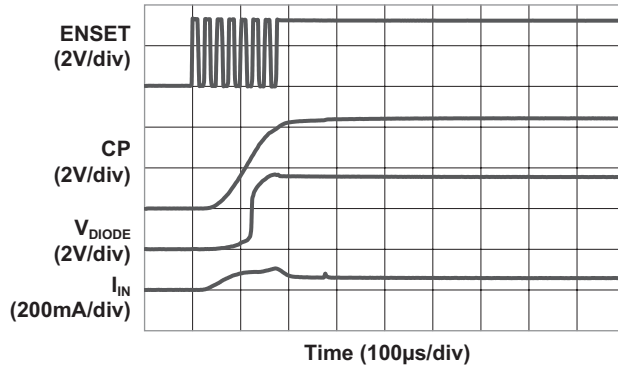

Turn-On to Full-Scale Charge Pump

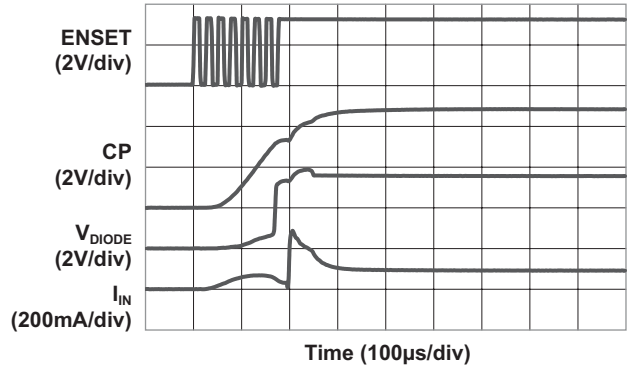

Turn-Off from Full-Scale Charge Pump

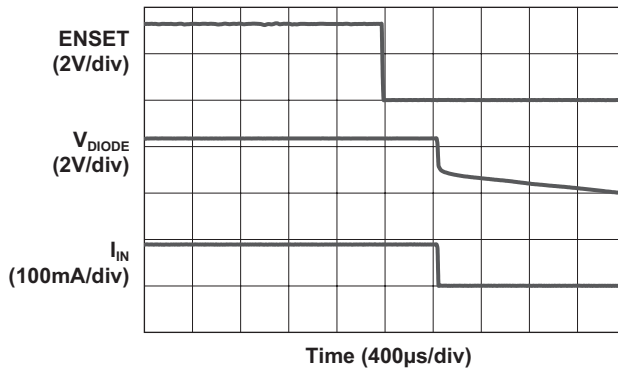

$I_{DIODE}$  vs. Input Voltage  
(3x20mA)

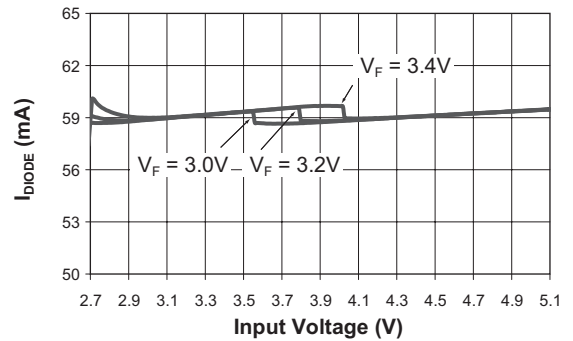

$I_{DIODE}$  vs. Input Voltage  
(3x8.3mA)

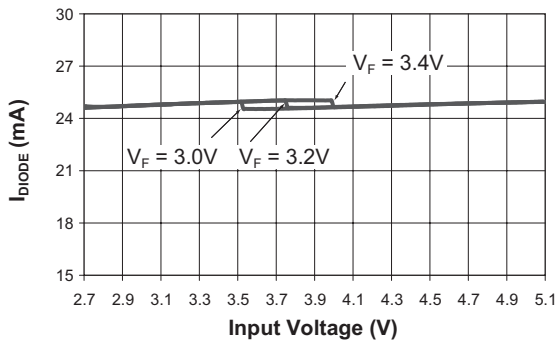

### Typical Characteristics

**Efficiency vs. Input Voltage**  
(3x20mA)

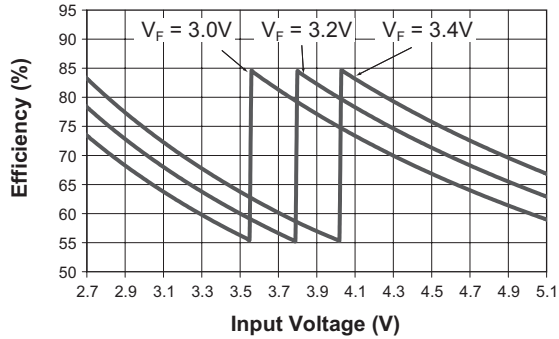

**Efficiency vs. Input Voltage**  
(3x8.3mA)

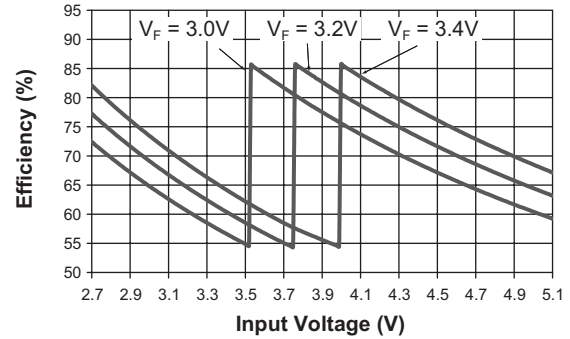

**60mA Load Characteristics**

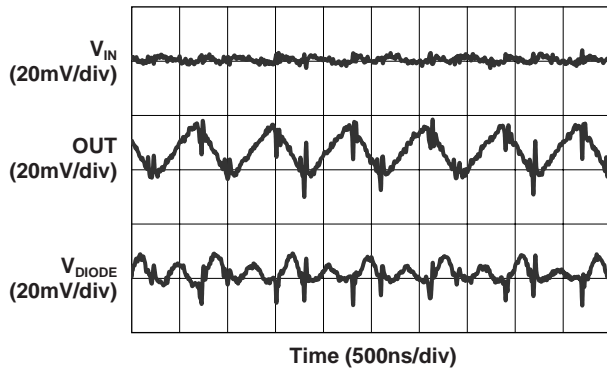

**Charge Pump to Load Switch (60mA)**

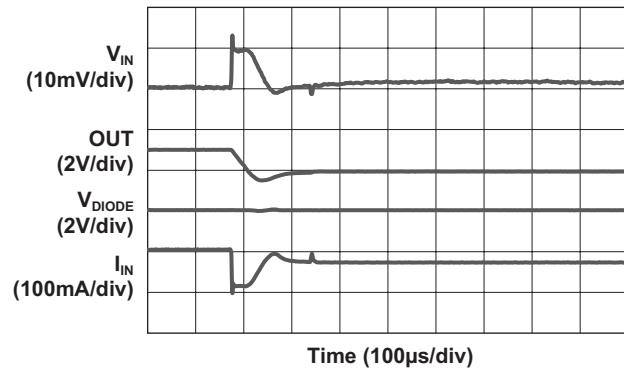

**Load Switch to Charge Pump (60mA)**

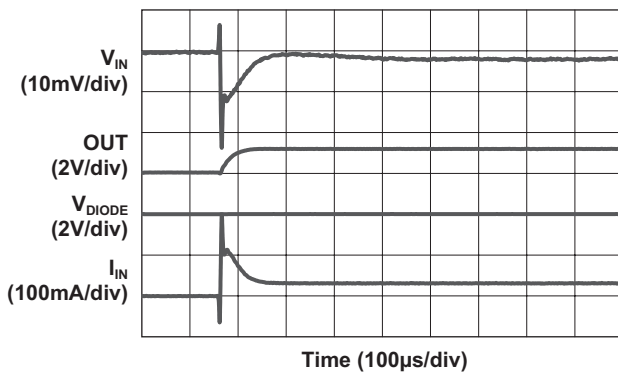

### Functional Block Diagram

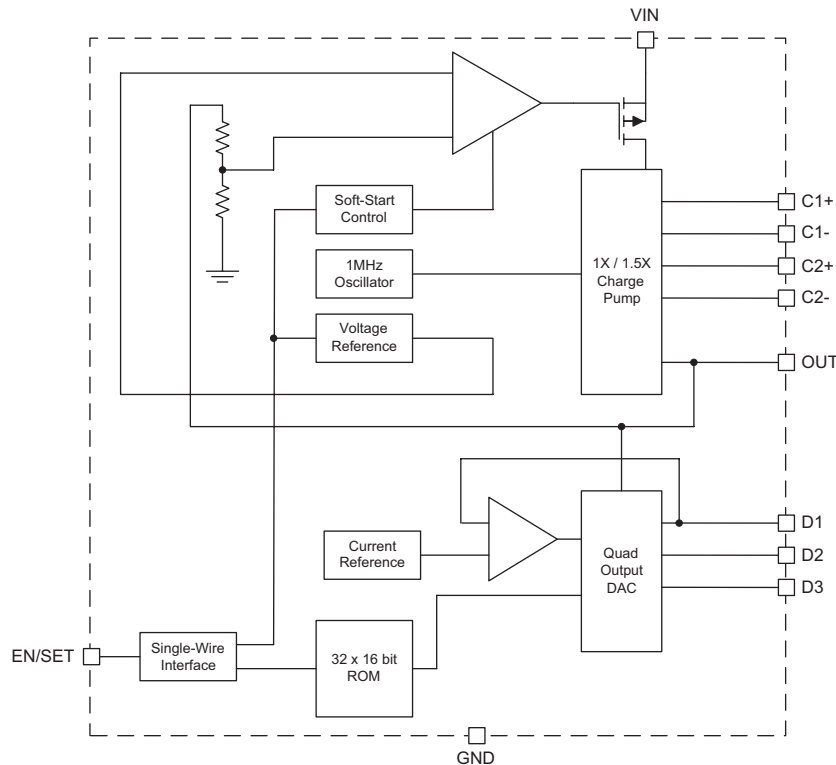

### Functional Description

The AAT3120 is a dual mode load switch (1X) and high efficiency (1.5X) fractional charge pump device intended for white LED backlight applications. The fractional charge pump consists of a low dropout linear voltage regulator followed by a 1.5X charge pump with multiple current source outputs. To maximize power conversion efficiency, an internal feedback control sensing circuit monitors the voltage required on the constant current source outputs. This control circuit then sets the load switch and charge pump functions based upon the input voltage level versus the output voltage level needed. The 1X load switch / 1.5X charge pump mode is decided on the voltage sensed on the output D1. Switchover between the 1.5X (charge-pump) operating mode and the 1X (load switch) mode occurs automatically (as a function of input and output voltages) and does not require user intervention to maintain maximum efficiency.

The AAT3120 requires only four external components: two  $1\mu\text{F}$  ceramic capacitors for the charge pump flying capacitors (C1 and C2), one  $1\mu\text{F}$  ceramic input capacitor ( $C_{\text{IN}}$ ), and one  $0.33\mu\text{F}$  to  $1\mu\text{F}$  ceramic output capacitor ( $C_{\text{OUT}}$ ). The LDO / 1.5X charge pump output is converted into three (D1 to D3) constant current outputs to drive three individual LEDs with a maximum current of 20mA each. The current source output magnitude is controlled by the EN/SET serial data single-wire interface. The interface records rising edges of the EN/SET pin and decodes them into eight individual current level settings (see Table 1, Current Level Settings). Once the final clock cycle is input for the desired brightness level, the EN/SET pin is held high to maintain the device output current at the programmed level. The device is disabled  $500\mu\text{s}$  after the EN/SET pin transitions to a logic low state.

Code	$I_{OUT}$ , Each LED (mA)
1	0
2	0.5
3	1.3
4	3.3
5	8.3
6	11.1
7	15
8	20

**Table 1: Current Level Settings.**

### Constant Current Output Level Settings

The constant current source output amplitude for output D1 to D3 is set via the serial interface. Because the outputs D1 to D3 are true independent constant current sources, the voltage observed on any single given output will be determined by the actual forward voltage ( $V_F$ ) for the LED being driven.

Since the output current of the AAT3120 is programmable through its simple single-wire serial interface, no PWM (pulse width modulation) or additional control circuitry is needed to control LED brightness. This feature greatly reduces the burden on a microcontroller or system IC to manage LED or display brightness, allowing the user to "set it and forget it."

### EN/SET Serial Interface

The current source output magnitude is controlled by the EN/SET serial data single-wire interface. The interface records rising edges of the EN/SET

pin and decodes them into eight individual current level settings. Code 8 is full scale.

The counter can be clocked at speeds up to 1MHz, so intermediate states are not visible. The first rising edge of EN/SET enables the IC and initially sets the output LED current to zero. The next lowest setting is equal to 525 $\mu$ A. Once the final clock cycle is input for the desired brightness level, the EN/SET pin is held high to maintain the device output current at the programmed level. The device is disabled 500 $\mu$ s after the EN/SET pin transitions to a logic low state. The EN/SET timing is designed to accommodate a wide range of data rates. After the first rising edge of EN/SET, the charge pump is enabled and reaches full capacity after the soft-start time ( $T_{SS}$ ). During the soft-start time, multiple clock pulses may be entered on the EN/SET pin to set the final output current level with a single burst of clocks. Alternatively, the EN/SET clock pulses may be entered one at a time to gradually increase the LED brightness over any desired time period. A constant current is sourced as long as EN/SET remains in a logic high state. The current source outputs are switched off after EN/SET has remained in a low state for at least the  $T_{OFF}$  timeout period.

### Test Current/Channel Disable

Each channel of the output is equipped with a test current function. A small amount of current ( $\sim 2\mu$ A) is injected into each output current source to detect the presence of load (LED). For unused channels that are tied to ground or load LED fail short, those channels will be automatically disabled instead of wasting the programmed output current.

### EN/SET Timing

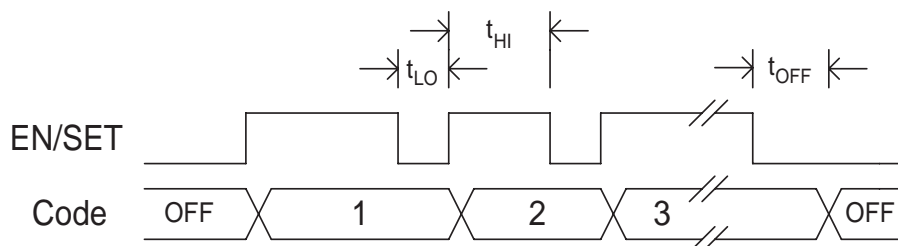



## Applications Information

### LED Selection

The AAT3120 is specifically intended for driving white LEDs. However, the device design will allow the AAT3120 to drive most types of LEDs with forward voltage specifications ranging from 2.0V to 4.3V. LED applications may include main and sub-LCD display backlighting, camera photo-flash applications, color (RGB) LEDs, infrared (IR) diodes for remotes, and other loads benefiting from a controlled output current generated from a varying input voltage. Since the D1 to D3 output current sources are matched with negligible voltage dependence, the LED brightness will be matched regardless of the specific LED forward voltage ( $V_F$ ) levels.

In some instances (e.g., in high-luminous-output applications such as photo-flash) it may be necessary to drive high- $V_F$  type LEDs. The *low-dropout* current-sources in the AAT3120 make it capable of driving LEDs with forward voltages as high as 4.3V at full current from an input supply as low as 3.0V. Outputs can be paralleled to drive high current LEDs without complication.

### Device Switching Noise Performance

The AAT3120 operates at a fixed frequency of approximately 1MHz to control noise and limit harmonics that can interfere with the RF operation of cellular telephone handsets or other communication devices. Back-injected noise appearing on the input pin of the charge pump is 20mV peak-to-peak, typically ten times less than inductor-based DC/DC boost converter white LED backlight solutions. The AAT3120 soft-start feature prevents noise transient effects associated with in-rush currents during start up of the charge pump circuit.

### Power Efficiency and Device Evaluation

The charge pump efficiency discussion in the following sections only accounts for efficiency of the charge pump section itself. Due to the unique circuit architecture and design of the AAT3120, it is very difficult to measure efficiency in terms of a percent value comparing input power over output power.

Since the AAT3120 outputs are pure constant current sources and typically drive individual loads, it is difficult to measure the output voltage for a given output (D1 to D3) to derive an overall output power measurement. For any given application, white LED forward voltage levels can differ, yet the output drive current will be maintained as a constant. This makes quantifying output power a difficult task when taken in the context of comparing to other white LED driver circuit topologies. A better way to quantify total device efficiency is to observe the total input power to the device for a given LED current drive level. The best white LED driver for a given application should be based on trade-offs of size, external components count, reliability, operating range, and total energy usage...*not just % efficiency.*

The AAT3120 efficiency may be quantified under very specific conditions and is dependent upon the input voltage versus the output voltage seen across the loads applied to outputs D1 through D3 for a given constant current setting. Depending upon the case of  $V_{IN}$  being greater than the specific voltage seen across the load on D1, the device will operate in "load switch" mode. If the voltage seen on the constant current source output is less than  $V_{IN}$ , then the device will operate in 1.5X charge pump mode. Each of these two modes will yield different efficiency values. One should refer to the following two sections for explanations of each operational mode.

### Load Switch Mode Efficiency

The AAT3120 load switch mode is operational at all times. It functions alone to enhance device power conversion efficiency when the condition exists where  $V_{IN}$  is greater than the voltages at the constant current source outputs. When in "load switch" mode, the voltage conversion efficiency is defined as output power divided by input power:

$$\eta = \frac{P_{OUT}}{P_{IN}}$$

The expression to define the ideal efficiency ( $\eta$ ) can be rewritten as:

$$\eta = \frac{P_{OUT}}{P_{IN}} = \frac{V_{OUT} \times I_{OUT}}{V_{IN} \times I_{OUT}} = \frac{V_{OUT}}{V_{IN}}$$

-or-

$$\eta(\%) = 100 \left( \frac{V_{OUT}}{V_{IN}} \right)$$

### Charge Pump Section Efficiency

The AAT3120 contains a fractional charge pump which will boost the input supply voltage in the event where  $V_{IN}$  is less than the voltage required on the constant current source outputs. The efficiency ( $\eta$ ) can be simply defined as a linear voltage regulator with an effective output voltage that is equal to one and one half times the input voltage. Efficiency ( $\eta$ ) for an ideal 1.5X charge pump can typically be expressed as the output power divided by the input power.

$$\eta = \frac{P_{OUT}}{P_{IN}}$$

In addition, with an ideal 1.5X charge pump, the output current may be expressed as 2/3 of the input current. The expression to define the ideal efficiency ( $\eta$ ) can be rewritten as:

$$\eta = \frac{P_{OUT}}{P_{IN}} = \frac{V_{OUT} \times I_{OUT}}{V_{IN} \times 1.5I_{OUT}} = \frac{V_{OUT}}{1.5V_{IN}}$$

-or-

$$\eta(\%) = 100 \left( \frac{V_{OUT}}{1.5V_{IN}} \right)$$

For a charge pump with an output of 5 volts and a nominal input of 3.5 volts, the theoretical efficiency is 95%. Due to internal switching losses and IC quiescent current consumption, the actual efficiency can be measured at 93%. These figures are in

close agreement for output load conditions from 1mA to 100mA. Efficiency will decrease as load current drops below 0.05mA or when level of  $V_{IN}$  approaches  $V_{OUT}$ . Refer to the Typical Characteristics section of this document for measured plots of efficiency versus input voltage and output load current for the given charge pump output voltage options.

### Ballast Resistors for Current Matching

In some applications, white LED forward voltages can vary significantly. Ballast resistors between the LED cathodes and ground are recommended for balancing the forward voltage differences. The ballast resistor value may be approximated by the following equation:

$$R_B = \frac{V_{SOURCE} - V_F}{I_F}$$

### Capacitor Selection

Careful selection of the four external capacitors  $C_{IN}$ ,  $C_1$ ,  $C_2$ , and  $C_{OUT}$  is important because they will affect turn-on time, output ripple, and transient performance. Optimum performance will be obtained when low Equivalent Series Resistance (ESR) ceramic capacitors are used. In general, low ESR may be defined as less than 100m $\Omega$ . A value of 1 $\mu$ F for all four capacitors is a good starting point when choosing capacitors. If the LED current sources are only programmed for light current levels, then the capacitor size may be decreased.

### Capacitor Characteristics

Ceramic composition capacitors are highly recommended over all other types of capacitors for use with the AAT3120. Ceramic capacitors offer many advantages over their tantalum and aluminum electrolytic counterparts. A ceramic capacitor typically has very low ESR, is lowest cost, has a smaller PCB footprint, and is non-polarized. Low ESR ceramic capacitors help maximize charge pump transient response. Since ceramic capacitors are non-polarized, they are not prone to incorrect connection damage.

### Equivalent Series Resistance

ESR is an important characteristic to consider when selecting a capacitor. ESR is a resistance internal to a capacitor, which is caused by the leads, internal connections, size or area, material composition, and ambient temperature. Capacitor ESR is typically measured in milliohms for ceramic capacitors and can range to more than several ohms for tantalum or aluminum electrolytic capacitors.

### **Ceramic Capacitor Materials**

Ceramic capacitors less than 0.1 $\mu$ F are typically made from NPO or C0G materials. NPO and C0G materials typically have tight tolerance and are stable over temperature. Large capacitor values are typically composed of X7R, X5R, Z5U, or Y5V dielectric materials. Large ceramic capacitors, typically greater than 2.2 $\mu$ F, are often available in low-cost Y5V and Z5U dielectrics, but capacitors greater than 1 $\mu$ F are typically not required for AAT3120 applications.

Capacitor area is another contributor to ESR. Capacitors that are physically large will have a lower ESR when compared to an equivalent material smaller capacitor. These larger devices can improve circuit transient response when compared to an equal value capacitor in a smaller package size.

### **Thermal Protection**

The AAT3120 has a thermal protection circuit that will shut down the internal LDO and charge pump if the die temperature rises above the thermal limit, as is the case during a short circuit of the OUT pin.

### **Charge Pump Compatibility**

The AAT3120 is pin-compatible with the AAT3113 in TSOPJW-12 packages, with no D4 output. Compared to the AAT3113, the AAT3120 offers an improved overall efficiency, wider operating range, and the ability to drive high- $V_F$  type LEDs (up to 4.3V) at full current from a 3V input condition. The AAT3120 is well suited for battery-powered applications using single-cell Lithium-Ion (Li-Ion) batteries (4.2V to 2.8V), Lithium Polymer batteries, and 3-series connected dry cells (3.6V).

### Additional Application Circuits

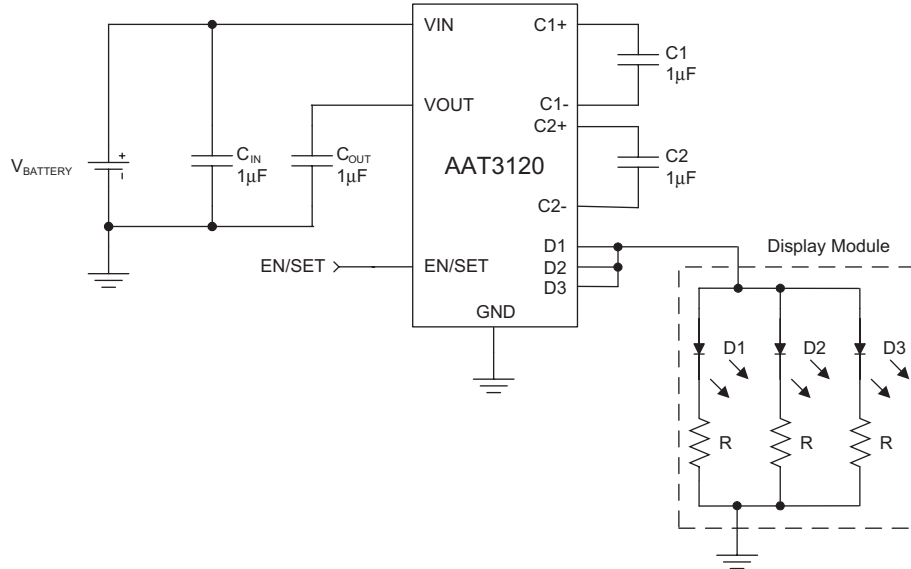

**AAT3120 Driving a Display Module with Three Paralleled White LEDs.**

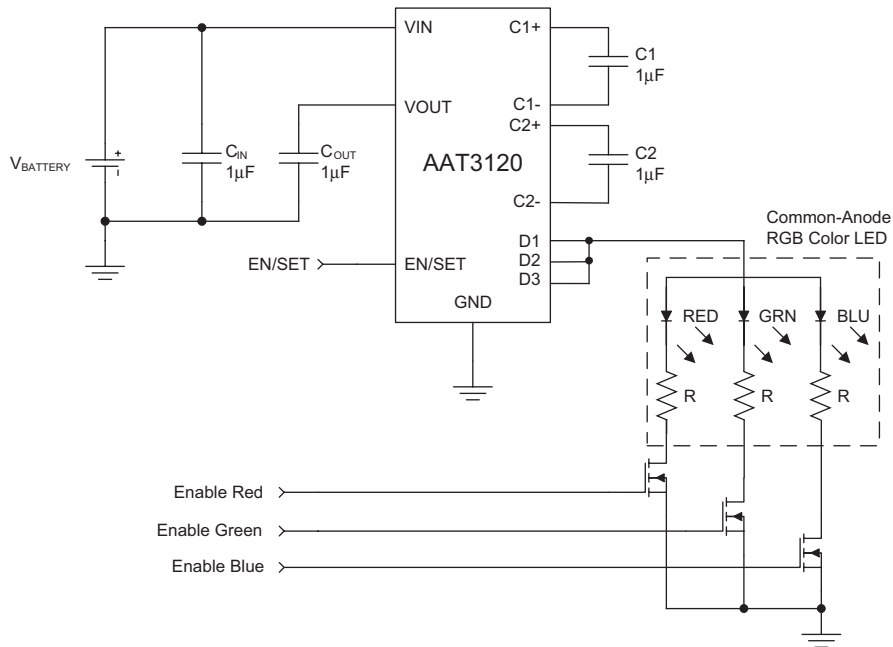

**AAT3120 Driving Common-Anode RGB Color LED.**

### Ordering Information

Package	Marking <sup>1</sup>	Part Number (Tape and Reel) <sup>2</sup>
TSOPJW-12	NGXY	<b>AAT3120ITP-T1</b>



All AnalogicTech products are offered in Pb-free packaging. The term “Pb-free” means semiconductor products that are in compliance with current RoHS standards, including the requirement that lead not exceed 0.1% by weight in homogeneous materials. For more information, please visit our website at <http://www.analogictech.com/pbfree>.

### Package Information

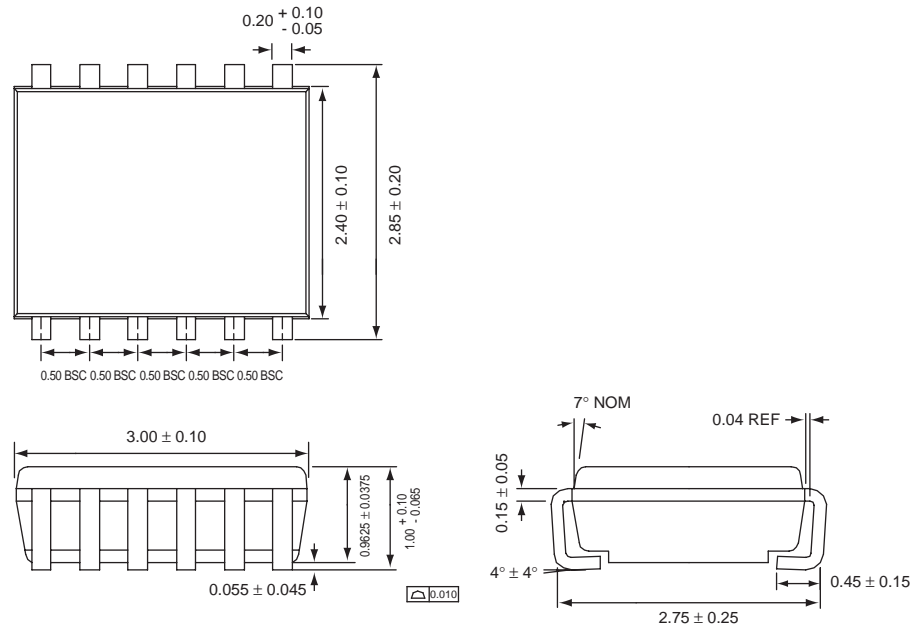

All dimensions in millimeters.

1. XYY = assembly and date code.  
2. Sample stock is generally held on part numbers listed in **BOLD**.

© Advanced Analogic Technologies, Inc.

AnalogicTech cannot assume responsibility for use of any circuitry other than circuitry entirely embodied in an AnalogicTech product. No circuit patent licenses, copyrights, mask work rights, or other intellectual property rights are implied. AnalogicTech reserves the right to make changes to their products or specifications or to discontinue any product or service without notice. Customers are advised to obtain the latest version of relevant information to verify, before placing orders, that information being relied on is current and complete. All products are sold subject to the terms and conditions of sale supplied at the time of order acknowledgement, including those pertaining to warranty, patent infringement, and limitation of liability. AnalogicTech warrants performance of its semiconductor products to the specifications applicable at the time of sale in accordance with AnalogicTech's standard warranty. Testing and other quality control techniques are utilized to the extent AnalogicTech deems necessary to support this warranty. Specific testing of all parameters of each device is not necessarily performed.

**Advanced Analogic Technologies, Inc.**  
**830 E. Arques Avenue, Sunnyvale, CA 94085**  
**Phone (408) 737-4600**  
**Fax (408) 737-4611**