

Ceramic High Pass Filter

1700 to 6300 MHz

NEW!
HFCN-1500



BLUE CELL™

Maximum Ratings

Operating Temperature	-55°C to 100°C
Storage Temperature	-55°C to 100°C
RF Power Input*	7W max. at 25°C

*Passband rating, derate linearly to 3W at 100°C ambient.

Pin Connections

RF IN	1**
RF OUT	3**
GROUND	2,4

**RF IN & RF OUT can be interchanged

Features

- low cost
- small size
- 7 sections
- temperature stable
- dc block in/out, breakdown voltage, 1kV typ.
- excellent power handling, 7W

Applications

- sub-harmonic rejection and dc blocking
- transmitters/receivers
- lab use

Model	Price	Qty.
HFCN-1500	\$1.99	(10-49)
HFCN-1500D	\$2.49	(10-49)

High Pass Filter Electrical Specifications¹ (T_{AMB}=25°C)

MODEL NO.	STOP BAND (MHz)		f _{co} , MHz Nom. (loss < 3 dB) Typ.	PASSBAND (MHz)		VSWR Typ. Frequency (MHz) 1.5:1 Stopband	POWER INPUT (W)	NO. OF SECTIONS
	(loss > 40 dB) Min.	(loss > 20 dB) Min.		(loss < 1.3 dB) Max.	(loss < 2 dB) Typ.			
HFCN-1500	1140	1280	1550	1850-4400	1600-5500	20:1	7	7

1. For Applications requiring DC voltage to be applied to the Input or output, use HFCN-1500D (DC Resistance to ground is 100 Mohms min.)

Outline Drawing

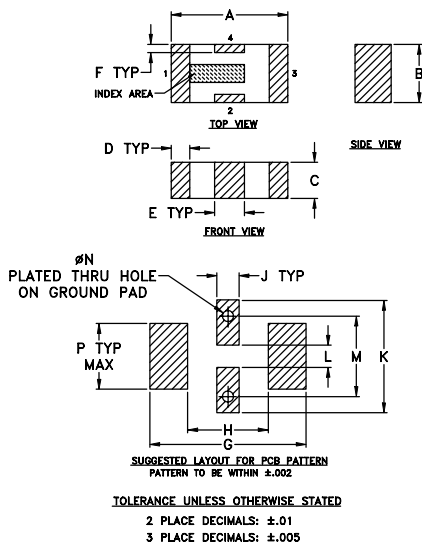

Outline Dimensions (inch)

A	B	C	D	E	F	G
.126	.063	.037	.024	.087	.012	.071
3.20	1.60	0.94	0.51	0.81	0.23	4.29

H	J	K	L	M	N	P	wt
.087	.024	.122	.024	.087	.012	.071	grams
2.21	0.61	3.10	0.61	2.21	0.30	1.80	.020

Demo Board MCL P/N: TB-270 Suggested PCB Layout (PL-137)

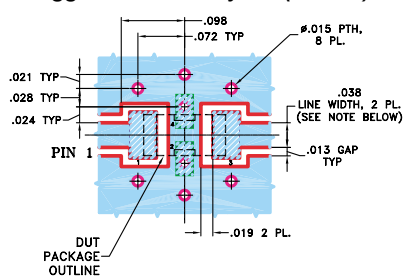

typical frequency response

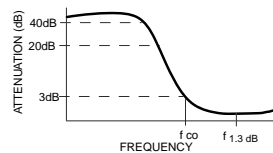

schematic

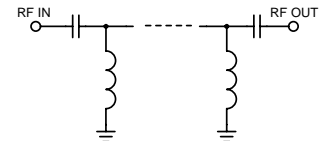

Typical Performance Data at 25°C

Frequency (MHz)	Insertion Loss (dB)	VSWR (:1)
1.00	105.45	1737.18
100.00	75.64	579.06
500.00	75.41	434.30
1140.00	38.65	33.42
1280.00	23.08	22.29
1520.00	3.30	2.53
1530.00	2.97	2.26
1620.00	1.36	1.25
1760.00	0.91	1.23
4000.00	0.67	1.65
4500.00	0.96	2.10
6500.00	2.88	4.74
7000.00	3.24	5.52
8000.00	4.00	6.97
9000.00	4.78	6.68

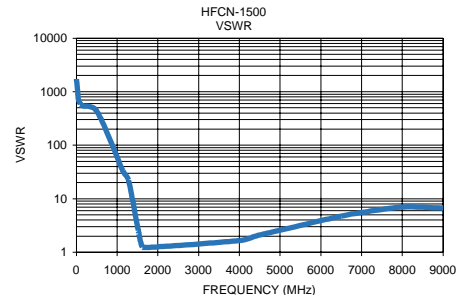
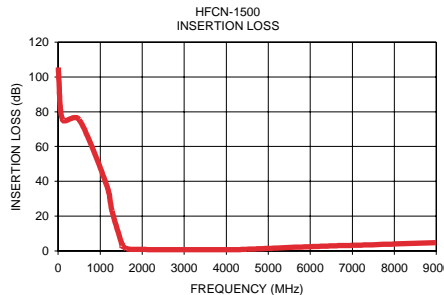

designers kit available

Kit No.	No. of Units in Kit	Description	Price \$ per Kit
K1-HFCN	40	5 of each: HFCN-650,-740,-1200,-1500,-1760,-2000,-2275,-2700	79.95



Distribution Centers NORTH AMERICA 800-654-7949 • 417-335-5935 • Fax 417-335-5945 • EUROPE 44-1252-832600 • Fax 44-1252-837010

Mini-Circuits ISO 9001 & ISO 14001 Certified

INTERNET <http://www.minicircuits.com>

P.O. Box 350166, Brooklyn, New York 11235-0003 (718) 934-4500 Fax (718) 332-4661

REV. C
M96263
EDR-6251/4
HFCN-1500
AD/RS/CP
050113