

Features

- Small sized 8-pin DIP type full molded package, optimum IC for low-height SMPS
- Off-timer circuit is provided on the monolithic control IC
- Low start-up circuit current (10uA typ)
- Low circuit current at operation (1.5mA typ)
- Avalanche energy guaranteed MOSFET with high VDSS
 - The built-in power MOSFET simplifies the surge absorption circuit since the MOSFET guarantees the avalanche energy.
 - No VDSS de-rating is required.
- Built-in Start-up circuit (the power loss in the start-up circuit is reduced by cutting off the start-up circuit after the IC starts its operation.)
- Auto Burst Stand-by (realizing input power < 0.1W at no load)
- Auto Bias Function (stable burst operation without the interference on transformer)
- Two operational modes by auto switching functions
 - For normal operation: PRC mode
 - For stand-by operation (at light load): Burst mode
- Built-in Leading Edge Blanking Function
- Built-in constant voltage drive circuit
- Various kinds of protection functions
 - Pulse-by-pulse Overcurrent Protection (OCP)
 - Overload Protection with auto recovery (OLP)
 - Overvoltage Protection with latch mode (OVP)
 - Thermal Shutdown with latch mode (TSD)

INTEGRATED SWITCHER

Package Outline

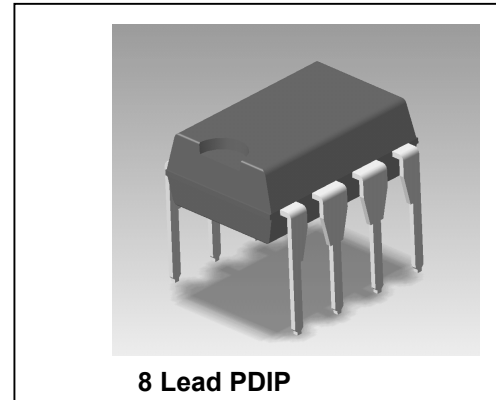

Key Specifications

Type	MOSFET VDSS(V)	RDS(ON) MAX	ACinput(V)	Pout(W) Note 1
IRIS-A6151	650	4Ω	230 ± 15%	10
			85 to 264	8

Descriptions

IRIS-A6151 is a hybrid IC consisting of a power MOSFET and a controller IC, designed for PRC fly-back converter type SMPS (Switching Mode Power Supply) applications, applicable for PRC operation for small power SMPS. This IC realizes downsizing and standardizing of a power supply system reducing external component count and simplifying the circuit design.

Note: PRC is abbreviation for “Pulse Ratio Control” (On-width control with fixed OFF-time).

Typical Connection Diagram

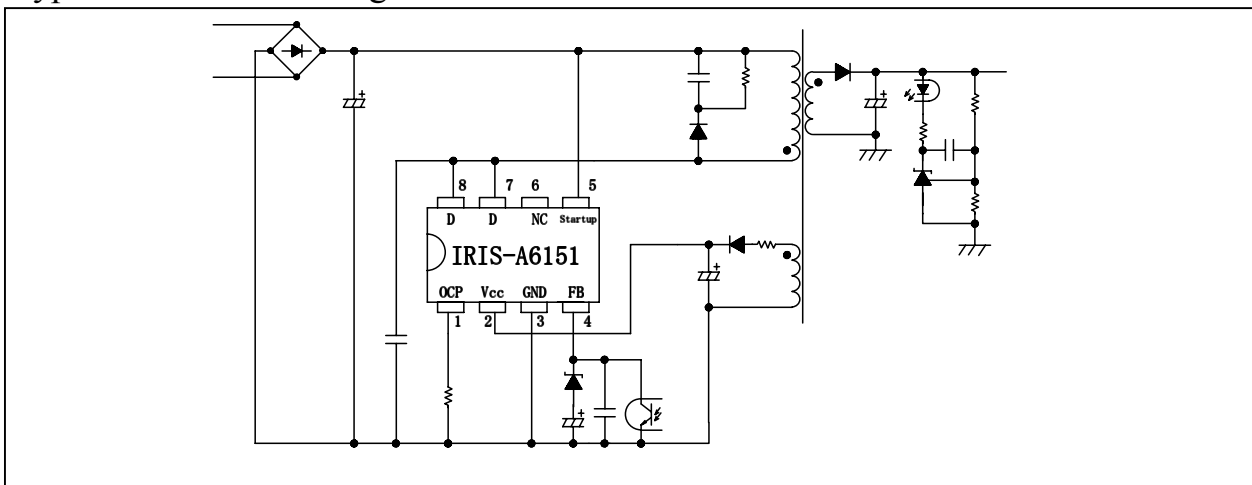

Note 1: The pout (W) represents the thermal rating at PRC Operation. The peak power output is obtained by approximating 120 to 140% of the above listed value. When the output voltage is low and ON-duty is narrow, the Pout (W) shall become lower than that of above value.

Absolute Maximum Ratings (Ta=25°C)

Absolute maximum ratings indicate sustained limits beyond which damage to the device may occur. All voltage parameters are absolute voltages referenced to terminals stated, all currents are defined positive into any lead. The thermal resistance and power dissipation ratings are measured under board mounted and still air conditions.

Symbol	Definition	Terminals	Max. Ratings	Units	Note
IDpeak	Drain Current *1	8-3	2.5	A	Single Pulse
IDMAX	Maximum switching current	8-3	2.5	A	V1-3=0.86V
					Ta=-20~+125°C
EAS	Single pulse avalanche energy *2	8-3	72	mJ	Single Pulse
					VDD=99V, L=20mH IL=2.5A
VOCP	O.C.P. pin Voltage	1-3	-0.5~6	V	
VCC	Input voltage for control part	2-3	35	V	
VFB/OLP	F.B/O.L.P pin voltage	4-3	-0.5~10	V	
Vstartup	Startup pin voltage	5-3	-0.3~600	V	
PD1	Power dissipation for MOSFET *3	8-3	1.35	W	*5
PD2	Power dissipation for control part	2-3	0.15	W	Specified by Vcc × Icc
	(Control IC) *4				
TF	Internal frame temperature	-	-20 ~ +125	°C	Refer to recommended operating temperature
	in operation				
Top	Operating ambient temperature	-	-20 ~ +125	°C	
Tstg	Storage temperature	-	-40 ~ +125	°C	
Tch	Channel temperature	-	150	°C	

*1 Refer to MOSFET A.S.O curve

*2 Refer to MOSFET Tch-EAS curve

*3 Refer to MOSFET Ta-PD1 curve

*4 Refer to TF-PD2 curve for Control IC

*5 When embedding this hybrid IC onto the printed circuit board (board size 15mm × 15mm)

Electrical Characteristics (for Control IC)

Electrical characteristics for control part (Ta=25°C, Vin=20V, unless otherwise specified)

Symbol	Definition	Ratings			Units	Test Conditions
		MIN	TYP	MAX		
V _{CC(ON)}	Operation start voltage	16	17.5	19.2	V	V _{CC} =0→19.2V
V _{CC(OFF)}	Operation stop voltage	9	10	11	V	V _{CC} =19.2→9V
I _{CC(ON)}	Circuit current in operation	-	-	4	mA	-
I _{CC(OFF)}	Circuit current in non-operation	-	-	50	μA	V _{CC} =14V
V _{CC(bias)}	Auto bias threshold voltage	9.6	10.6	11.6	V	V _{CC} =20→9.6V
-	V _{cc(bias)} - V _{cc(OFF)}	0.2	-	-	V	-
T _{OFF(MAX)}	Maximum OFF time	7.3	8	8.7	μsec	-
V _{OCP}	O.C.P. threshold voltage	0.69	0.77	0.86	V	-
T _{bw}	Leading edge blanking time	200	320	480	nsec	-
V _{burst}	Burst threshold voltage	0.7	0.79	0.88	V	-
V _{OLP}	O.L.P. threshold voltage	6.5	7.2	7.9	V	-
I _{OLP}	Out-flow current at O.L.P operation	18	26	35	μA	-
I _{FB(MAX)}	Maximum F.B. current	227	300	388	μA	-
I _{STARTUP}	Startup current	340	790	1230	μA	V _{CC} =15V
I _{START(leak)}	Startup circuit leakage current	-	-	30	μA	-
V _{CC(OVP)}	O.V.P operation voltage	28.7	31.2	34.1	V	V _{CC} =0→34.1V
I _{CC(H)}	Latch circuit sustaining current *6	-	-	200	μA	V _{CC} =34.1→8.5V
V _{CC(La.OFF)}	Latch circuit release voltage *6	6.6	7.3	8	V	V _{CC} =34.1→6.6V
T _{j(TSD)}	Thermal shutdown operating temperature	135	-	-	°C	-

*6 The latch circuit means a circuit operated O.V.P and T.S.D.

Electrical Characteristics (for MOSFET)

(Ta=25°C) unless otherwise specified

Symbol	Definition	Ratings			Units	Test Conditions
		MIN	TYP	MAX		
V _{DSS}	Drain-to-Source breakdown voltage	650	-	-	V	ID=300μA
						V _{I-3} =0V(short)
I _{DSS}	Drain leakage current	-	-	300	μA	V _D S=650V
						V _{I-3} =0V(short)
R _D S(ON)	On-resistance	-	-	4	Ω	ID=0.4A
t _f	Switching time	-	-	250	nsec	-
θ _{ch-F}	Thermal resistance *7	-	-	52	°C/W	Between channel and internal frame

*7 Internal frame temperature (T_F) is measured at the root of the Pin 3.

IRIS-A6151

IRIS-A6151
A.S.O. temperature derating coefficient curve

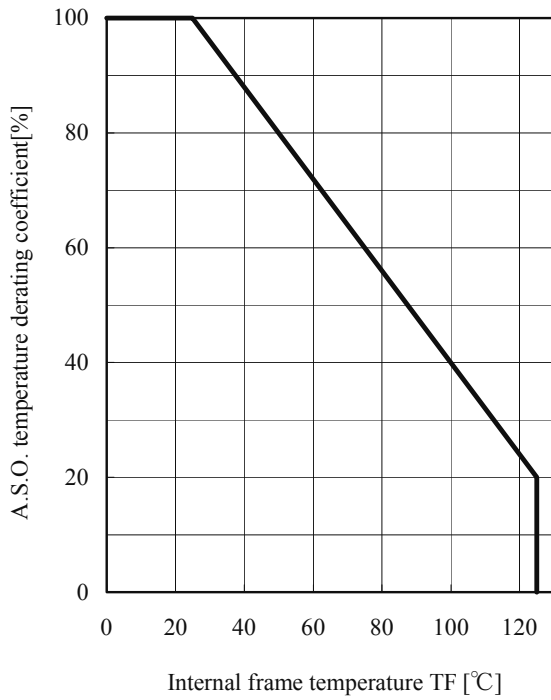

IRIS-A6151
MOSFET A.S.O. Curve Ta=25°C

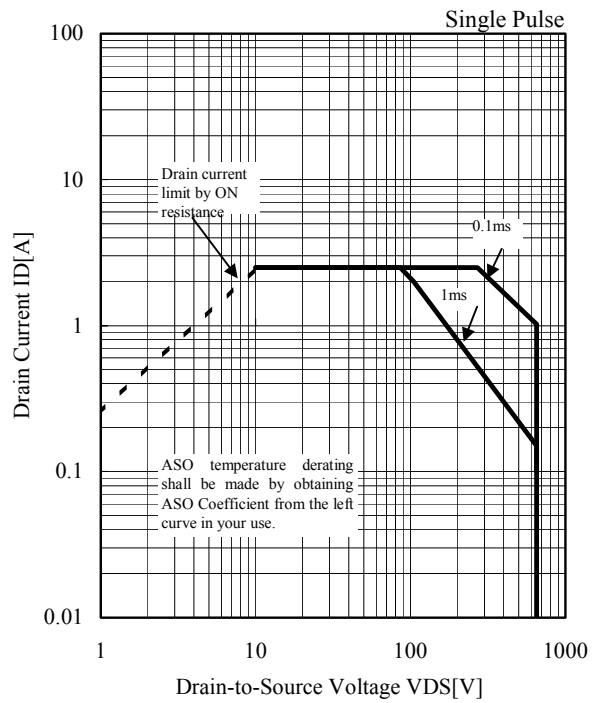

IRIS-A6151
Avalanche energy derating curve

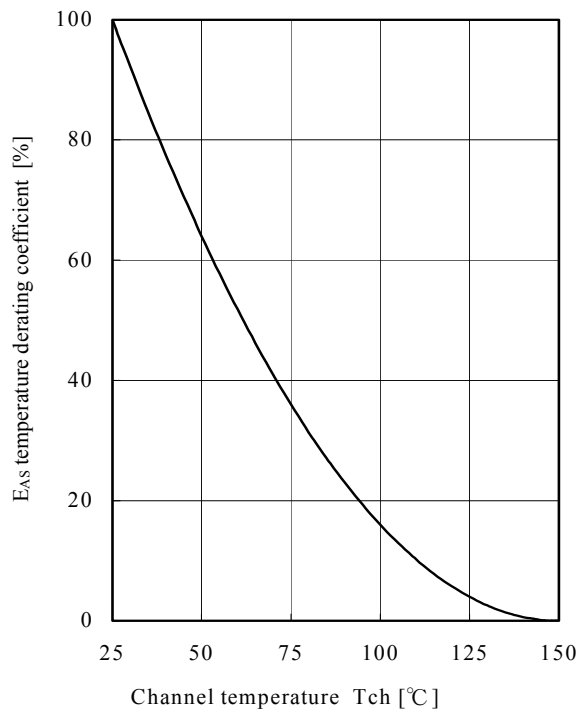

IRIS-A6151
MOSFET Ta-PD1 Curve

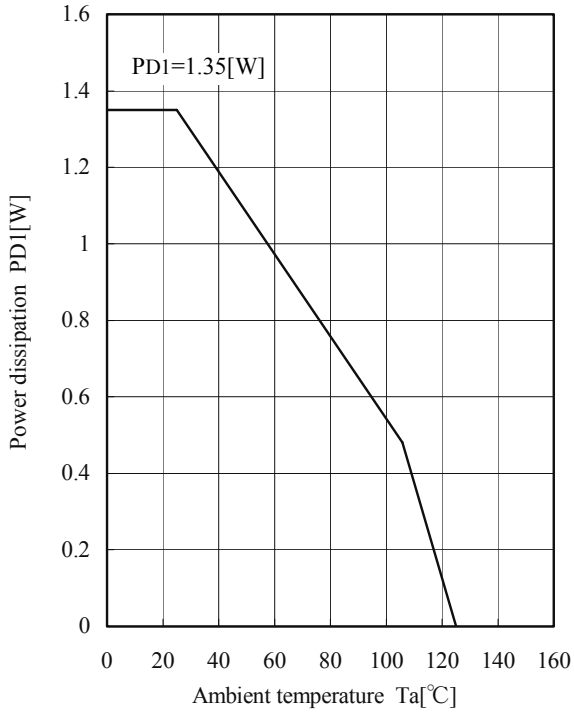

IRIS-A6151
MIC T_F - $PD2$ Curve

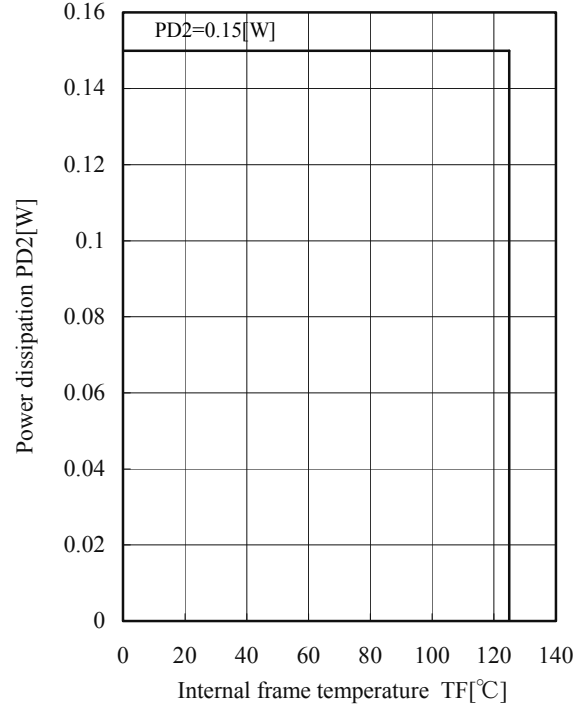

IRIS-A6151
Transient thermal resistance curve

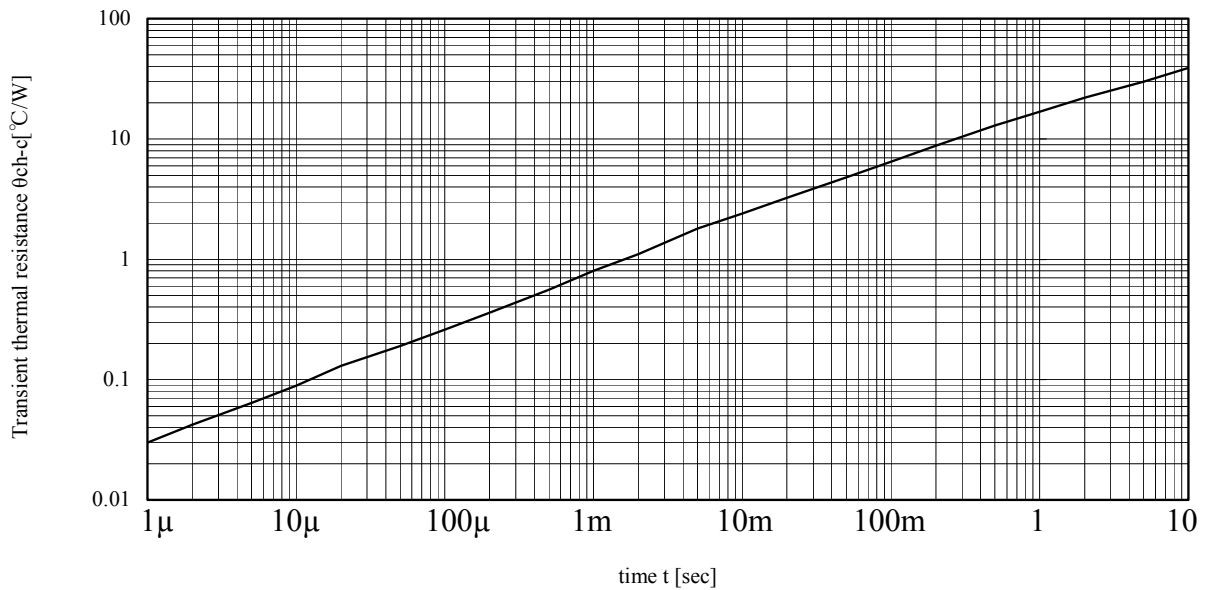

Block Diagram

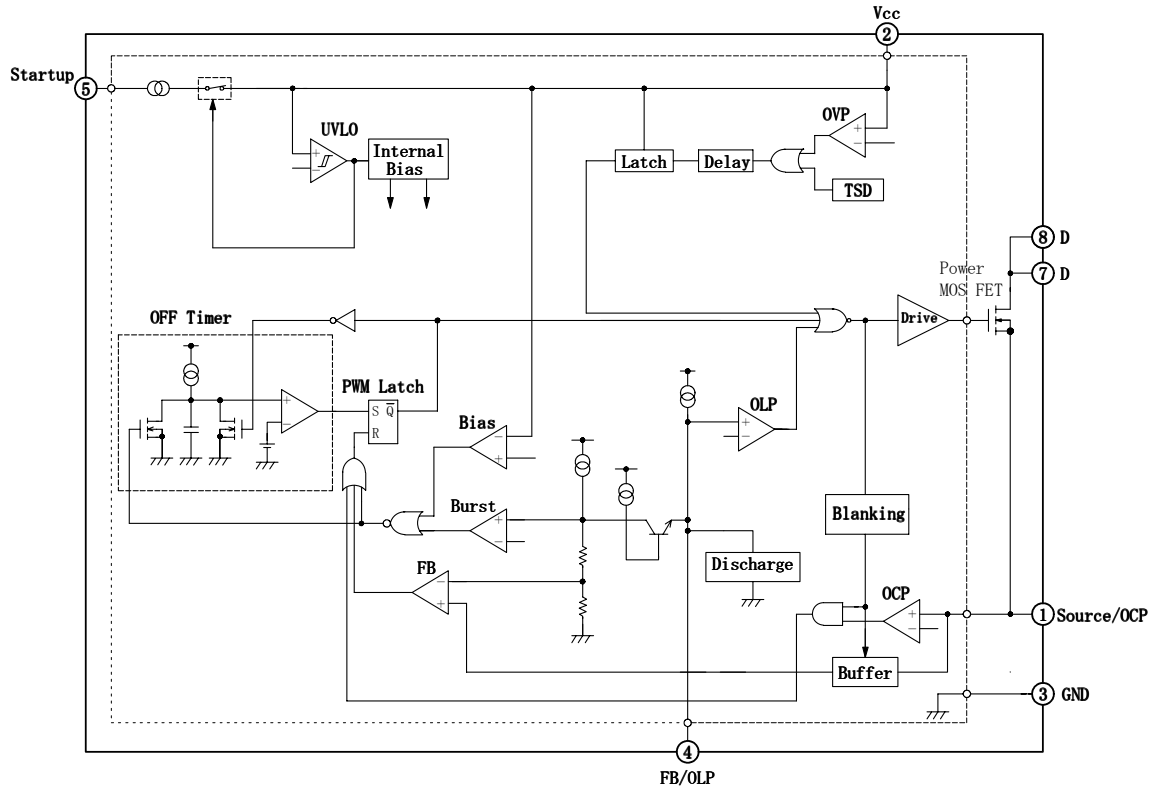

Lead Assignments

Pin Assignment (Top View)		Pin No.	Symbol	Description	Function
S/OCF	1	8	S/OCF	Source Pin/OCF	MOSFET source /Overcurrent Protection
VCC	2	7	VCC	Power supply Pin	Input of power supply for control circuit
GND	3	6	GND	Ground Pin	Ground
FB/OLP	4	5	FB/OLP	Feedback/OLP pin	Input of constant voltage control signal/over load protection signal
			Startup	Startup pin	Input of Startup current
			N.C.	-	Not Connected
			Drain	Drain Pin	MOSFET drain
			Drain	Drain Pin	MOSFET drain

Other Functions

O.V.P. – Overvoltage Protection Circuit

T.S.D. – Thermal Shutdown Circuit

Case Outline

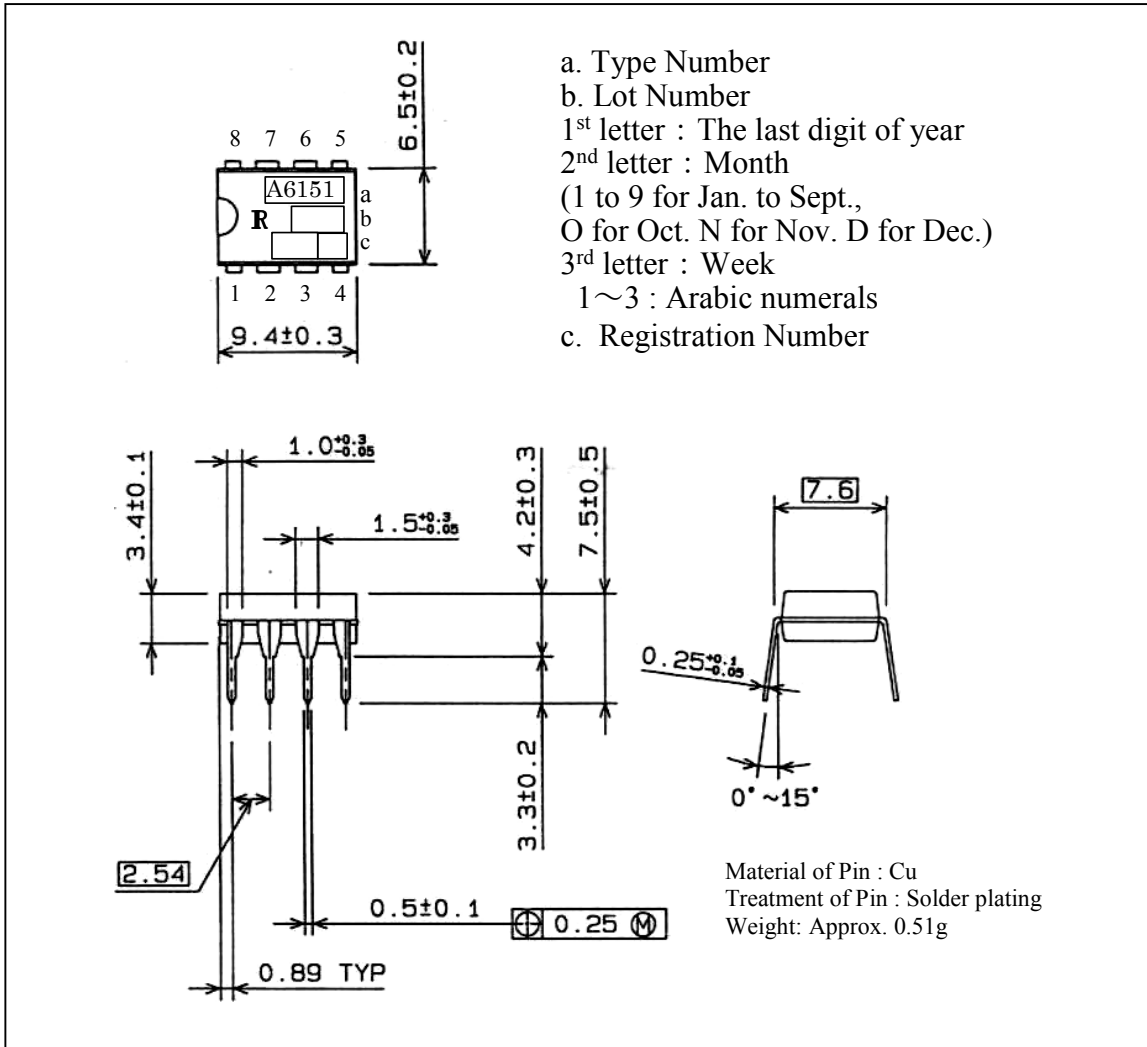

Data and specifications subject to change without notice.