

# IS61C256AL



## 32K x 8 HIGH-SPEED CMOS STATIC RAM

PRELIMINARY INFORMATION  
DECEMBER 2005

### FEATURES

- High-speed access time: 10, 12 ns
- CMOS Low Power Operation
  - 1 mW (typical) CMOS standby
  - 125 mW (typical) operating
- Fully static operation: no clock or refresh required
- TTL compatible inputs and outputs
- Single 5V power supply
- Lead-free available

### DESCRIPTION

The *ISSI* IS61C256AL is a very high-speed, low power, 32,768 word by 8-bit static RAMs. It is fabricated using *ISSI*'s high-performance CMOS technology. This highly reliable process coupled with innovative circuit design techniques, yields access times as fast as 10 ns maximum.

When  $\overline{CE}$  is HIGH (deselected), the device assumes a standby mode at which the power dissipation can be reduced down to 150  $\mu$ W (typical) with CMOS input levels.

Easy memory expansion is provided by using an active LOW Chip Enable ( $\overline{CE}$ ) input and an active LOW Output Enable ( $\overline{OE}$ ) input. The active LOW Write Enable ( $\overline{WE}$ ) controls both writing and reading of the memory.

The IS61C256AL is pin compatible with other 32Kx8 SRAMs and are available in 28-pin SOJ and TSOP (Type I) packages.

### FUNCTIONAL BLOCK DIAGRAM

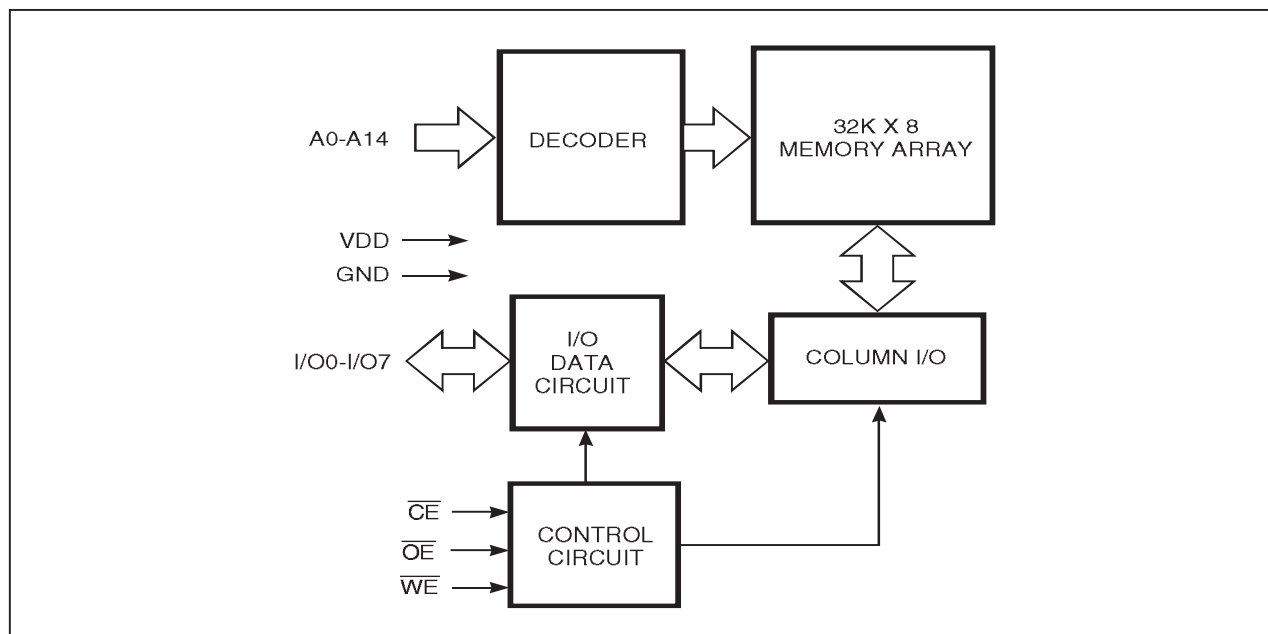

Copyright © 2005 Integrated Silicon Solution, Inc. All rights reserved. ISSI reserves the right to make changes to this specification and its products at any time without notice. ISSI assumes no liability arising out of the application or use of any information, products or services described herein. Customers are advised to obtain the latest version of this device specification before relying on any published information and before placing orders for products.

### PIN CONFIGURATION 28-Pin SOJ

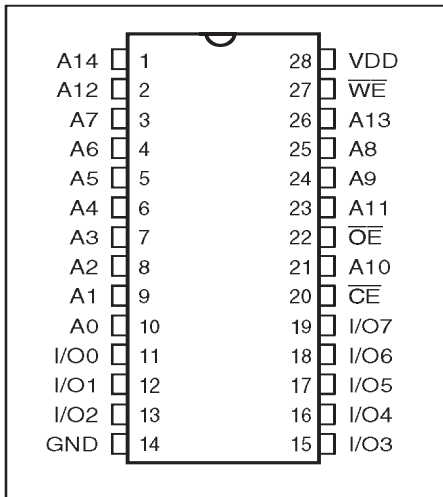

### PIN CONFIGURATION 28-Pin TSOP

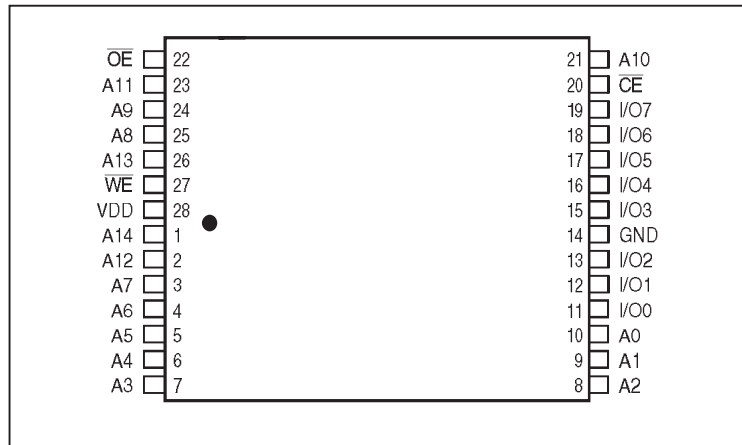

### PIN DESCRIPTIONS

A0-A14	Address Inputs
CE	Chip Enable Input
OE	Output Enable Input
WE	Write Enable Input
I/O0-I/O7	Bidirectional Ports
VDD	Power
GND	Ground

### TRUTH TABLE

Mode	WE	CE	OE	I/O Operation	V <sub>DD</sub> Current
Not Selected (Power-down)	X	H	X	High-Z	I <sub>SB1</sub> , I <sub>SB2</sub>
Output Disabled	H	L	H	High-Z	I <sub>CC</sub>
Read	H	L	L	DOUT	I <sub>CC</sub>
Write	L	L	X	DIN	I <sub>CC</sub>

### ABSOLUTE MAXIMUM RATINGS<sup>(1)</sup>

Symbol	Parameter	Value	Unit
V <sub>TERM</sub>	Terminal Voltage with Respect to GND	-0.5 to +7.0	V
T <sub>STG</sub>	Storage Temperature	-65 to +150	°C
P <sub>T</sub>	Power Dissipation	1.5	W
I <sub>OUT</sub>	DC Output Current (LOW)	20	mA

#### Note:

1. Stress greater than those listed under ABSOLUTE MAXIMUM RATINGS may cause permanent damage to the device. This is a stress rating only and functional operation of the device at these or any other conditions above those indicated in the operational sections of this specification is not implied. Exposure to absolute maximum rating conditions for extended periods may affect reliability.

## OPERATING RANGE

Range	Ambient Temperature	Speed (ns)	V <sub>DD</sub> (V)
Commercial	0°C to +70°C	-10	5V ± 5%
Commercial	0°C to +70°C	-12	5V ± 10%
Industrial	-40°C to +85°C	-12	5V ± 10%

## DC ELECTRICAL CHARACTERISTICS (Over Operating Range)

Symbol	Parameter	Test Conditions	Min.	Max.	Unit	
V <sub>OH</sub>	Output HIGH Voltage	V <sub>DD</sub> = Min., I <sub>OH</sub> = -4.0 mA	2.4	—	V	
V <sub>OL</sub>	Output LOW Voltage	V <sub>DD</sub> = Min., I <sub>OL</sub> = 8.0 mA	—	0.4	V	
V <sub>IH</sub>	Input HIGH Voltage		2.2	V <sub>DD</sub> + 0.5	V	
V <sub>IL</sub>	Input LOW Voltage <sup>(1)</sup>		-0.3	0.8	V	
I <sub>LI</sub>	Input Leakage	GND ≤ V <sub>IN</sub> ≤ V <sub>DD</sub>	Com. Ind.	-1 -2	1 2	μA
I <sub>LO</sub>	Output Leakage	GND ≤ V <sub>OUT</sub> ≤ V <sub>DD</sub> , Outputs Disabled	Com. Ind.	-1 -2	1 2	μA

Note: 1. V<sub>IL</sub> = -3.0V for pulse width less than 10 ns.

POWER SUPPLY CHARACTERISTICS<sup>(1)</sup> (Over Operating Range)

Symbol	Parameter	Test Conditions		-10		-12		Unit
				Min.	Max.	Min.	Max.	
I <sub>CC1</sub>	V <sub>DD</sub> Operating Supply Current	V <sub>DD</sub> = Max., $\overline{CE}$ = V <sub>IL</sub> I <sub>OUT</sub> = 0 mA, f = 0	Com.	—	20	—	20	mA
			Ind.	—	—	—	25	
I <sub>CC2</sub>	V <sub>DD</sub> Dynamic Operating Supply Current	V <sub>DD</sub> = Max., $\overline{CE}$ = V <sub>IL</sub> I <sub>OUT</sub> = 0 mA, f = f <sub>MAX</sub>	Com.	—	45	—	35	mA
			Ind.	—	—	—	40	
			typ. <sup>(2)</sup>			25		
I <sub>SB1</sub>	TTL Standby Current (TTL Inputs)	V <sub>DD</sub> = Max., V <sub>IN</sub> = V <sub>IH</sub> or V <sub>IL</sub> $\overline{CE}$ ≥ V <sub>IH</sub> , f = 0	Com.	—	1	—	1	mA
			Ind.	—	—	—	2	
I <sub>SB2</sub>	CMOS Standby Current (CMOS Inputs)	V <sub>DD</sub> = Max., $\overline{CE}$ ≥ V <sub>DD</sub> - 0.2V, V <sub>IN</sub> ≥ V <sub>DD</sub> - 0.2V, or V <sub>IN</sub> ≤ 0.2V, f = 0	Com.	—	350	—	350	μA
			Ind. typ. <sup>(2)</sup>	—	—	—	450 200	

## Note:

- At f = f<sub>MAX</sub>, address and data inputs are cycling at the maximum frequency, f = 0 means no input lines change.
- Typical values are measured at V<sub>DD</sub> = 5V, T<sub>A</sub> = 25°C and not 100% tested.

CAPACITANCE<sup>(1,2)</sup>

Symbol	Parameter	Conditions	Max.	Unit
C <sub>IN</sub>	Input Capacitance	V <sub>IN</sub> = 0V	8	pF
C <sub>OUT</sub>	Output Capacitance	V <sub>OUT</sub> = 0V	10	pF

## Notes:

- Tested initially and after any design or process changes that may affect these parameters.
- Test conditions: T<sub>A</sub> = 25°C, f = 1 MHz, V<sub>DD</sub> = 5.0V.

READ CYCLE SWITCHING CHARACTERISTICS<sup>(1)</sup> (Over Operating Range)

Symbol	Parameter	-10 ns		-12 ns		Unit
		Min.	Max	Min.	Max.	
t <sub>RC</sub>	Read Cycle Time	10	—	12	—	ns
t <sub>AA</sub>	Address Access Time	—	10	—	12	ns
t <sub>OHA</sub>	Output Hold Time	2	—	2	—	ns
t <sub>ACS</sub>	$\overline{\text{CE}}$ Access Time	—	10	—	12	ns
t <sub>DOE</sub>	$\overline{\text{OE}}$ Access Time	—	6	—	6	ns
t <sub>LZOE</sub> <sup>(2)</sup>	$\overline{\text{OE}}$ to Low-Z Output	0	—	0	—	ns
t <sub>HZOE</sub> <sup>(2)</sup>	$\overline{\text{OE}}$ to High-Z Output	—	5	—	6	ns
t <sub>LZCS</sub> <sup>(2)</sup>	$\overline{\text{CE}}$ to Low-Z Output	2	—	3	—	ns
t <sub>HZCS</sub> <sup>(2)</sup>	$\overline{\text{CE}}$ to High-Z Output	—	5	—	7	ns
t <sub>PU</sub> <sup>(3)</sup>	$\overline{\text{CE}}$ to Power-Up	0	—	0	—	ns
t <sub>PD</sub> <sup>(3)</sup>	$\overline{\text{CE}}$ to Power-Down	—	10	—	12	ns

**Notes:**

1. Test conditions assume signal transition times of 5 ns or less, timing reference levels of 1.5V, input pulse levels of 0 to 3.0V and output loading specified in Figure 1.
2. Tested with the load in Figure 2. Transition is measured  $\pm 500$  mV from steady-state voltage. Not 100% tested.
3. Not 100% tested.

## AC TEST CONDITIONS

Parameter	Unit
Input Pulse Level	0V to 3.0V
Input Rise and Fall Times	3 ns
Input and Output Timing and Reference Levels	1.5V
Output Load	See Figures 1 and 2

## AC TEST LOADS

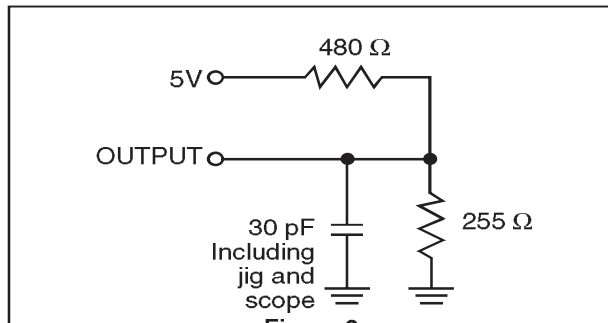

Figure 2

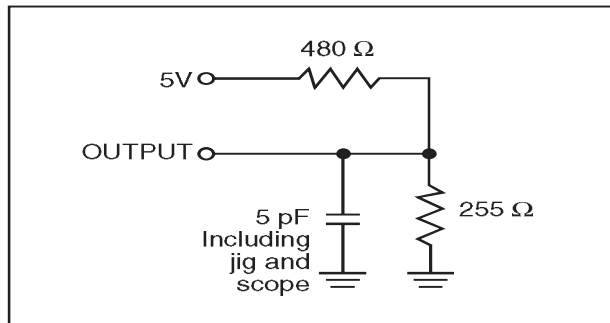
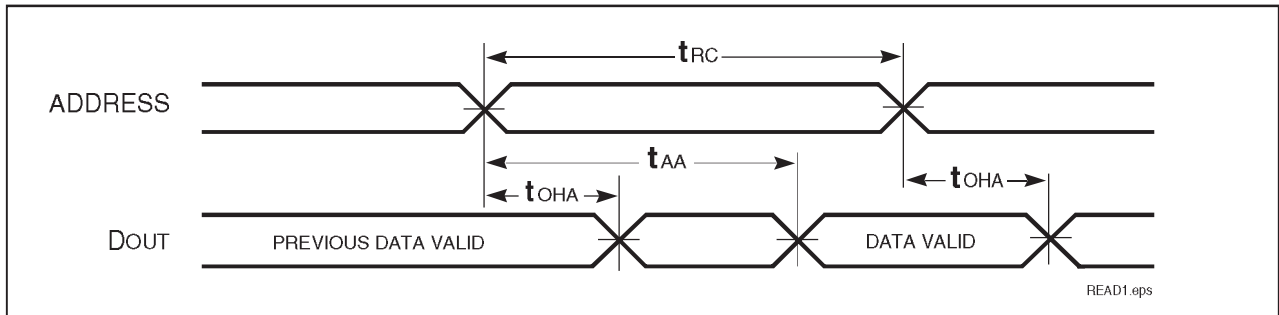
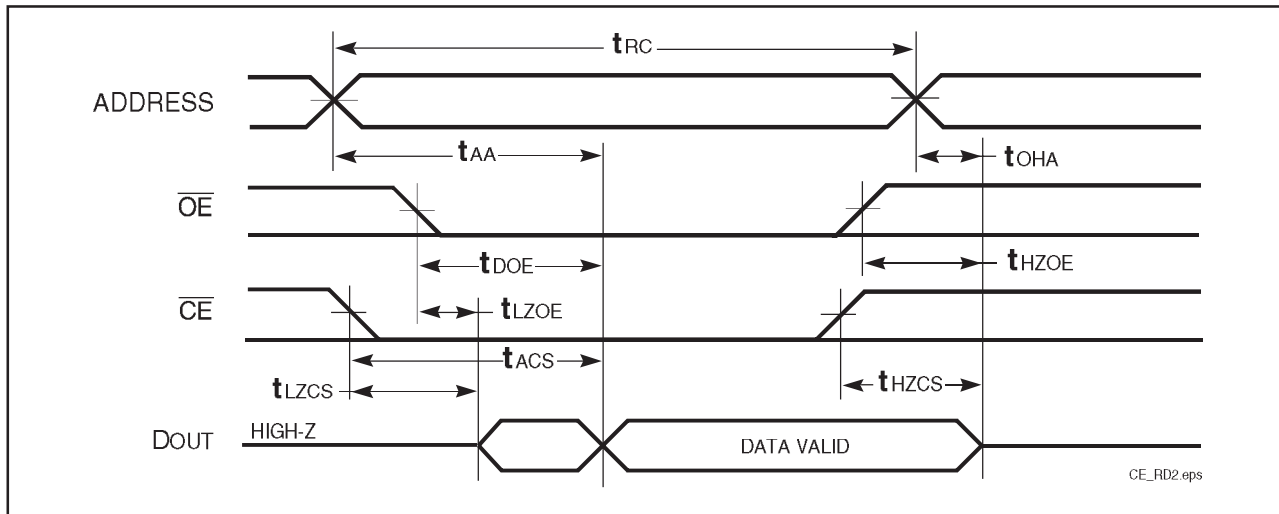

Figure 2

**AC WAVEFORMS**  
**READ CYCLE NO. 1<sup>(1,2)</sup>**



**READ CYCLE NO. 2<sup>(1,3)</sup>**



**Notes:**

1.  $\overline{WE}$  is HIGH for a Read Cycle.
2. The device is continuously selected.  $\overline{OE}, \overline{CE} = V_{IL}$ .
3. Address is valid prior to or coincident with  $\overline{CE}$  LOW transitions.

WRITE CYCLE SWITCHING CHARACTERISTICS<sup>(1,3)</sup> (Over Operating Range)

Symbol	Parameter	-10 ns		-12 ns		Unit
		Min.	Max	Min.	Max.	
$t_{WC}$	Write Cycle Time	10	—	12	—	ns
$t_{SCS}$	$\overline{CE}$ to Write End	9	—	10	—	ns
$t_{AW}$	Address Setup Time to Write End	9	—	10	—	ns
$t_{HA}$	Address Hold from Write End	0	—	0	—	ns
$t_{SA}$	Address Setup Time	0	—	0	—	ns
$t_{PWE1}$	$\overline{WE}$ Pulse Width ( $\overline{OE}$ LOW)	9	—	9	—	ns
$t_{PWE2}$	$\overline{WE}$ Pulse Width ( $\overline{OE}$ HIGH)	8	—	8	—	ns
$t_{SD}$	Data Setup to Write End	7	—	7	—	ns
$t_{HD}$	Data Hold from Write End	0	—	0	—	ns
$t_{HZWE}^{(2)}$	$\overline{WE}$ LOW to High-Z Output	—	6	—	6	ns
$t_{LZWE}^{(2)}$	$\overline{WE}$ HIGH to Low-Z Output	0	—	0	—	ns

## Notes:

- Test conditions assume signal transition times of 3 ns or less, timing reference levels of 1.5V, input pulse levels of 0 to 3.0V and output loading specified in Figure 1.
- Tested with the load in Figure 2. Transition is measured  $\pm 500$  mV from steady-state voltage. Not 100% tested.
- The internal write time is defined by the overlap of  $\overline{CE}$  LOW and  $\overline{WE}$  LOW. All signals must be in valid states to initiate a Write, but any one can go inactive to terminate the Write. The Data Input Setup and Hold timing are referenced to the rising or falling edge of the signal that terminates the write.

## AC WAVEFORMS

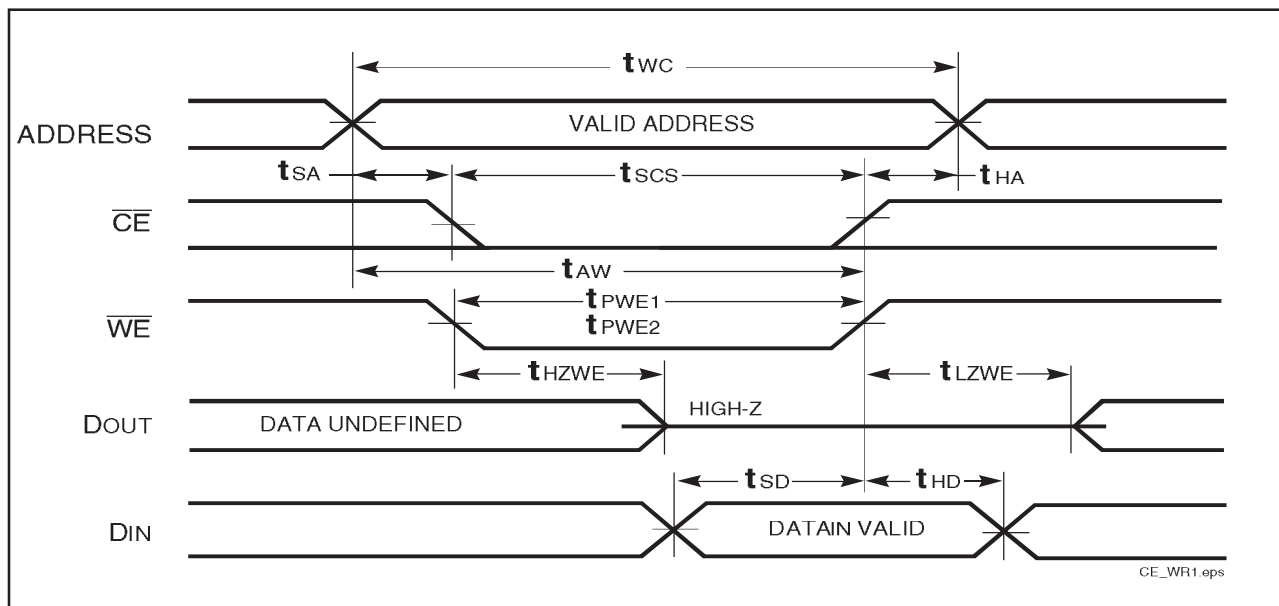
WRITE CYCLE NO. 1 ( $\overline{WE}$  Controlled)<sup>(1,2)</sup>

**WRITE CYCLE NO. 2** ( $\overline{OE}$  is HIGH During Write Cycle) <sup>(1,2)</sup>

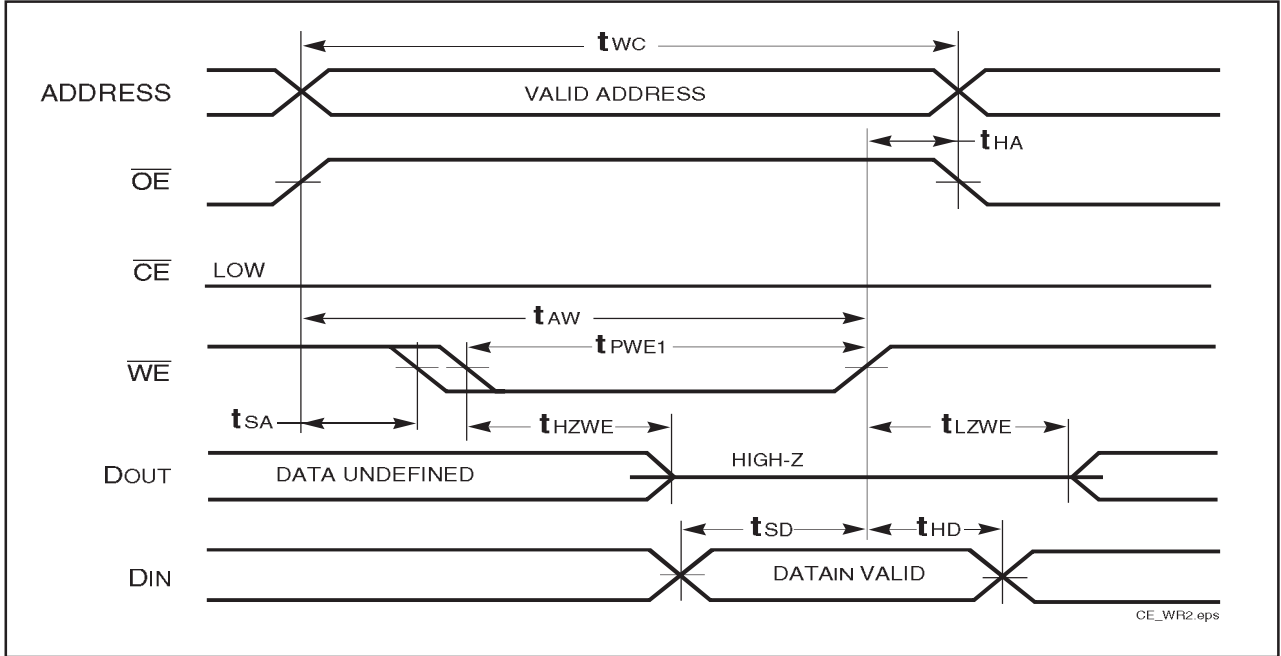

**WRITE CYCLE NO. 3** ( $\overline{OE}$  is LOW During Write Cycle) <sup>(1)</sup>

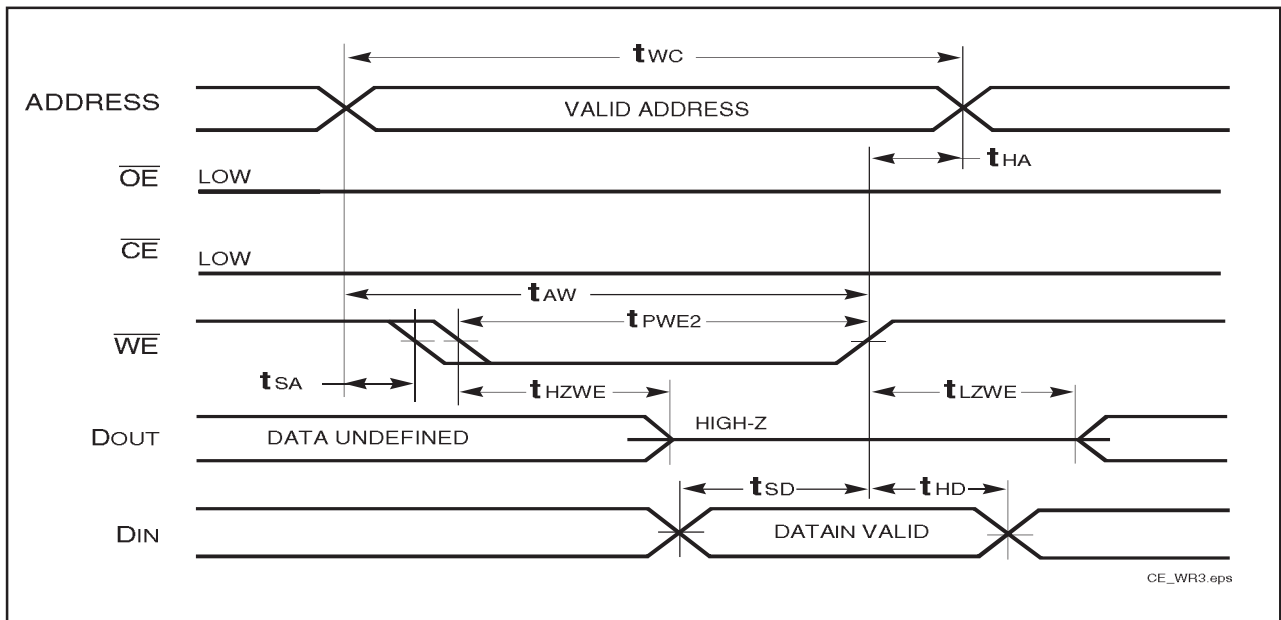

**Notes:**

1. The internal write time is defined by the overlap of  $\overline{CE}$  LOW and  $\overline{WE}$  LOW. All signals must be in valid states to initiate a Write, but any one can go inactive to terminate the Write. The Data Input Setup and Hold timing are referenced to the rising or falling edge of the signal that terminates the Write.
2. I/O will assume the High-Z state if  $\overline{OE} \geq V_{IH}$ .

**DATA RETENTION SWITCHING CHARACTERISTICS**

Symbol	Parameter	Test Condition	Min.	Typ. <sup>(1)</sup>	Max.	Unit
V <sub>DR</sub>	V <sub>DD</sub> for Data Retention	See Data Retention Waveform	2.0		5.5	V
I <sub>DR</sub>	Data Retention Current	V <sub>DD</sub> = 2.0V, $\overline{CE} \geq V_{DD} - 0.2V$ V <sub>IN</sub> ≥ V <sub>DD</sub> - 0.2V, or V <sub>IN</sub> ≤ V <sub>SS</sub> + 0.2V	—	50	90	μA
t <sub>SDR</sub>	Data Retention Setup Time	See Data Retention Waveform	0		—	ns
t <sub>RDR</sub>	Recovery Time	See Data Retention Waveform	t <sub>RC</sub>		—	ns

**Note:**

1. Typical Values are measured at V<sub>DD</sub> = 5V, T<sub>A</sub> = 25°C and not 100% tested.

**DATA RETENTION WAVEFORM ( $\overline{CE}$  Controlled)**

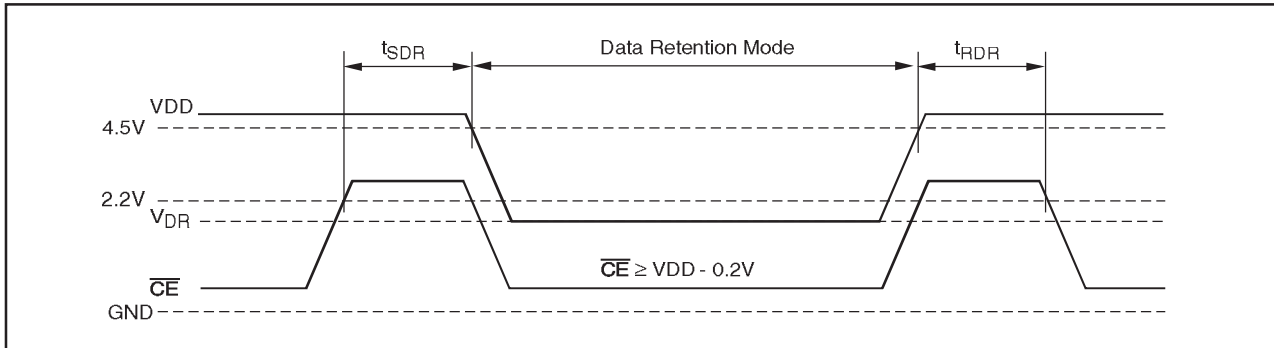



**ORDERING INFORMATION: IS61C256AL****Commercial Range: 0°C to +70°C**

<b>Speed (ns)</b>	<b>Order Part Number</b>	<b>Package</b>
10	IS61C256AL-10J	300-mil Plastic SOJ
	IS61C256AL-10JL	300-mil Plastic SOJ, Lead-free
	IS61C256AL-10T	TSOP (Type 1)
	IS61C256AL-10TL	TSOP (Type 1), Lead-free
12	IS61C256AL-12J	300-mil Plastic SOJ
	IS61C256AL-12JL	300-mil Plastic SOJ, Lead-free
	IS61C256AL-12T	TSOP (Type 1)
	IS61C256AL-12TL	TSOP (Type 1), Lead-free

**Industrial Range: -40°C to +85°C**

<b>Speed (ns)</b>	<b>Order Part Number</b>	<b>Package</b>
12	IS61C256AL-12JI	300-mil Plastic SOJ
	IS61C256AL-12JLI	300-mil Plastic SOJ, Lead-free
	IS61C256AL-12TI	TSOP (Type 1)
	IS61C256AL-12TLI	TSOP (Type 1), Lead-free

## PACKAGING INFORMATION

**300-mil Plastic SOJ**  
**Package Code: J**

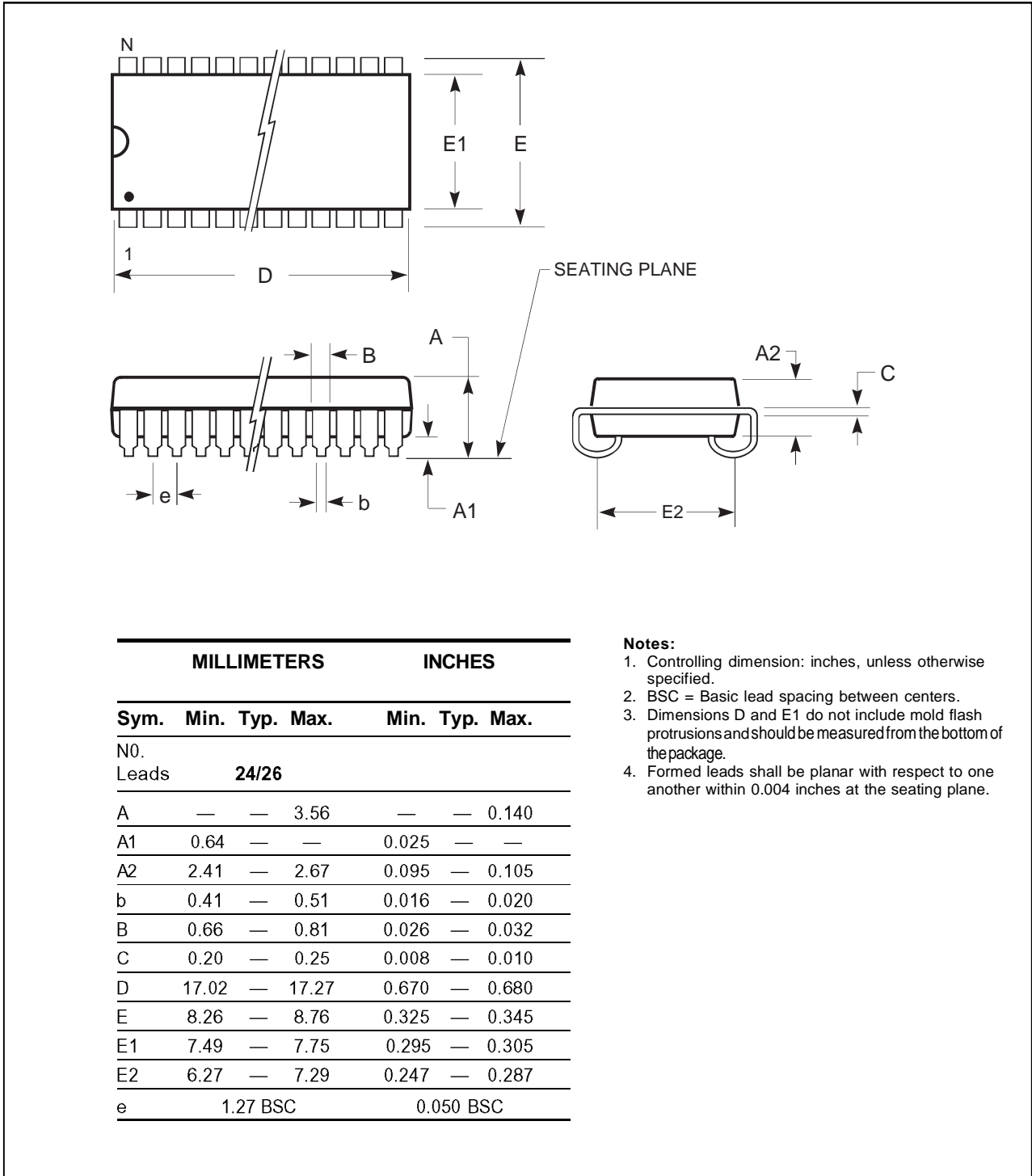

Copyright © 2003 Integrated Silicon Solution, Inc. All rights reserved. ISSI reserves the right to make changes to this specification and its products at any time without notice. ISSI assumes no liability arising out of the application or use of any information, products or services described herein. Customers are advised to obtain the latest version of this device specification before relying on any published information and before placing orders for products.

**Integrated Silicon Solution, Inc. — www.issi.com — 1-800-379-4774**

Rev. D  
 02/25/03

# PACKAGING INFORMATION



300-mil Plastic SOJ  
Package Code: J

MILLIMETERS				INCHES		
Sym.	Min.	Typ.	Max.	Min.	Typ.	Max.
NO. Leads <b>28</b>						
A	—	—	3.56	—	—	0.140
A1	0.64	—	—	0.025	—	—
A2	2.41	—	2.67	0.095	—	0.105
b	0.41	—	0.51	0.016	—	0.020
B	0.66	—	0.81	0.026	—	0.032
C	0.20	—	0.25	0.008	—	0.010
D	18.29	—	18.54	0.720	—	0.730
E	8.26	—	8.76	0.325	—	0.345
E1	7.49	—	7.75	0.295	—	0.305
E2	6.27	—	7.29	0.247	—	0.287
e	1.27 BSC			0.050 BSC		

MILLIMETERS				INCHES		
Sym.	Min.	Typ.	Max.	Min.	Typ.	Max.
NO. Leads <b>32</b>						
A	—	—	3.56	—	—	0.140
A1	0.64	—	—	0.025	—	—
A2	2.41	—	2.67	0.095	—	0.105
b	0.41	—	0.51	0.016	—	0.020
B	0.66	—	0.81	0.026	—	0.032
C	0.20	—	0.25	0.008	—	0.010
D	20.83	—	21.08	0.820	—	0.830
E	8.26	—	8.76	0.325	—	0.345
E1	7.49	—	7.75	0.295	—	0.305
E2	6.27	—	7.29	0.247	—	0.287
e	1.27 BSC			0.050 BSC		

# PACKAGING INFORMATION



Plastic TSOP - 28-pins  
 Package Code: T (Type I)

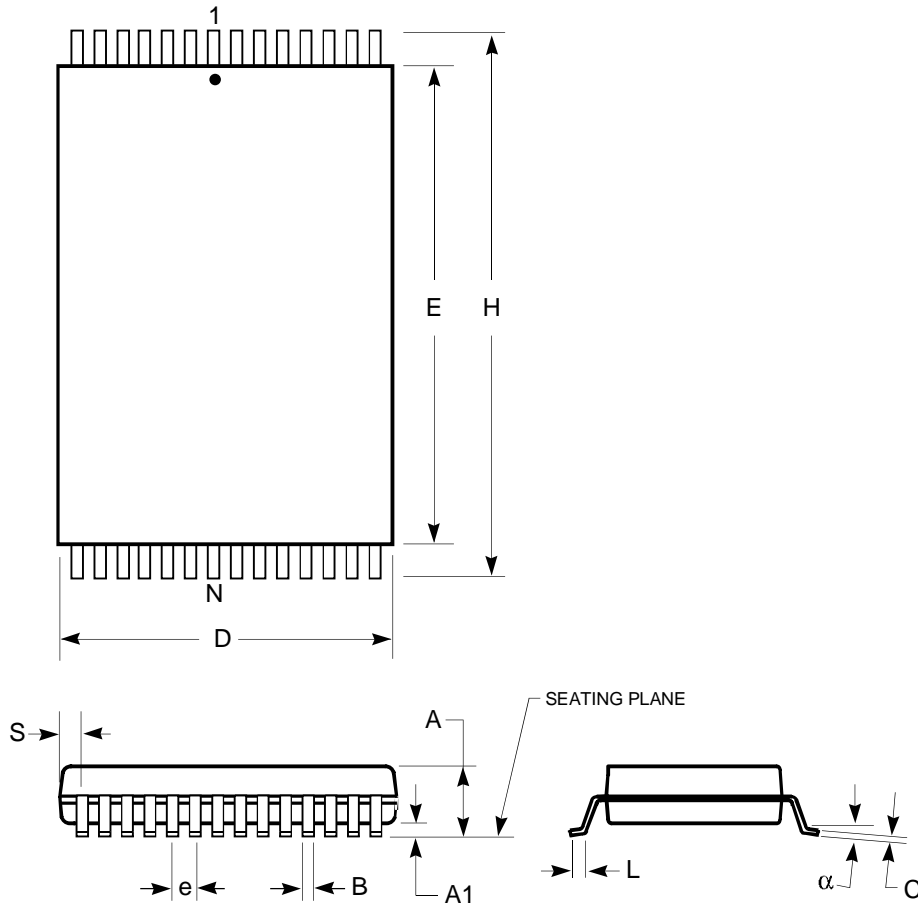

Plastic TSOP (T—Type I)				
Symbol	Millimeters		Inches	
	Min	Max	Min	Max
Ref. Std.				
No. Leads	<b>28</b>			
A	1.00	1.20	0.037	0.047
A1	0.05	0.20	0.002	0.008
B	0.16	0.27	0.006	0.011
C	0.10	0.20	0.004	0.008
D	7.90	8.10	0.308	0.316
E	11.70	11.90	0.456	0.465
H	13.20	13.60	0.515	0.531
e	0.55 BSC		0.022 BSC	
L	0.30	0.70	0.011	0.027
$\alpha$	0°	5°	0°	5°

**Notes:**

1. Controlling dimension: millimeters, unless otherwise specified.
2. BSC = Basic lead spacing between centers.
3. Dimensions D and E do not include mold flash protrusions and should be measured from the bottom of the package.
4. Formed leads shall be planar with respect to one another within 0.004 inches at the seating plane.