

**CSDD-8M
CSDD-8N**

**SILICON CONTROLLED RECTIFIER
8.0 AMP, 600 THRU 800 VOLTS**

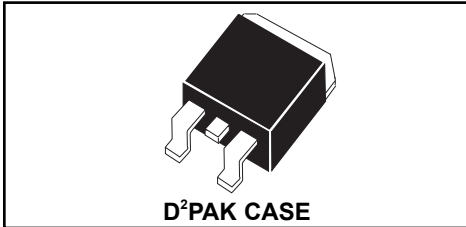

Central™

Semiconductor Corp.

DESCRIPTION:

The CENTRAL SEMICONDUCTOR CSDD-8M series type is an Epoxy Molded Silicon Controlled Rectifier designed for sensing circuit applications and control systems.

MARKING CODE: FULL PART NUMBER

MAXIMUM RATINGS: ($T_C=25^\circ\text{C}$ unless otherwise noted)

	SYMBOL	CSDD -8M	CSDD -8N	UNITS
Peak Repetitive Off-State Voltage	V_{DRM}, V_{RRM}	600	800	V
RMS On-State Current ($T_C=90^\circ\text{C}$)	$I_T(\text{RMS})$		8.0	A
Peak One Cycle Surge ($t=10\text{ms}$)	I_{TSM}		70	A
I^2t Value for Fusing ($t=10\text{ms}$)	I^2t		24	A ² s
Peak Gate Power ($t_p=10\mu\text{s}$)	P_{GM}		40	W
Average Gate Power Dissipation	$P_G (AV)$		1.0	W
Peak Forward Gate Current ($t_p=10\mu\text{s}$)	I_{FGM}		4.0	A
Peak Forward Gate Voltage ($t_p=10\mu\text{s}$)	V_{FGM}		16	V
Peak Reverse Gate Voltage ($t_p=10\mu\text{s}$)	V_{RGM}		5.0	V
Critical Rate of Rise of On-State Current	di/dt		50	A/ μs
Storage Temperature	T_{stg}	-40 to +150		$^\circ\text{C}$
Junction Temperature	T_J	-40 to +125		$^\circ\text{C}$
Thermal Resistance	θ_{JA}		60	$^\circ\text{C/W}$
Thermal Resistance	θ_{JC}		2.5	$^\circ\text{C/W}$

ELECTRICAL CHARACTERISTICS: ($T_C=25^\circ\text{C}$ unless otherwise noted)

SYMBOL	TEST CONDITIONS	MIN	TYP	MAX	UNITS
I_{DRM}, I_{RRM}	Rated V_{DRM}, V_{RRM}			10	μA
I_{DRM}, I_{RRM}	Rated $V_{DRM}, V_{RRM}, T_C=125^\circ\text{C}$			2.0	mA
I_{GT}	$V_D=12\text{V}, R_L=10\Omega$		3.0	15	mA
I_H	$I_T=100\text{mA}$		7.3	20	mA
V_{GT}	$V_D=12\text{V}, R_L=10\Omega$		0.9	1.5	V
V_{TM}	$I_{TM}=16\text{A}, t_p=380\mu\text{s}$		1.3	1.8	V
dv/dt	$V_D=2/3 V_{DRM}, T_C=125^\circ\text{C}$	200			V/ μs

R1 (24-September 2004)

SILICON CONTROLLED RECTIFIER
8.0 AMP, 600 THRU 800 VOLTS

D²PAK CASE - MECHANICAL OUTLINE

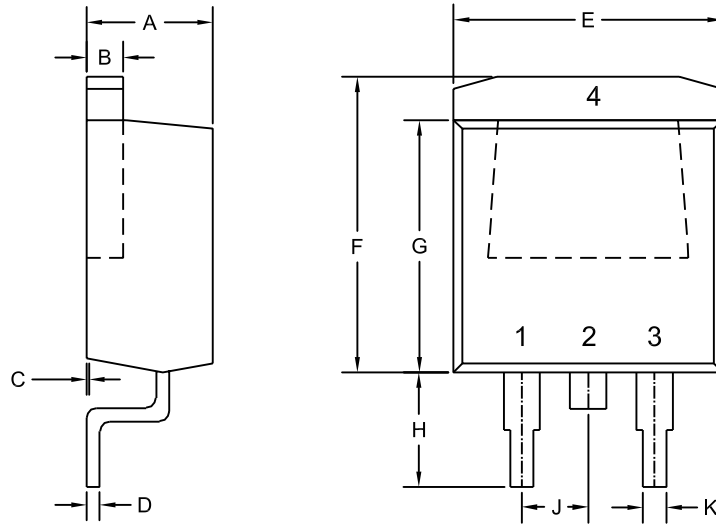

R2

LEAD CODE:

- 1) CATHODE
- 2) ANODE
- 3) GATE
- 4) ANODE

MARKING CODE:

FULL PART NUMBER

SYMBOL	DIMENSIONS			
	INCHES		MILLIMETERS	
	MIN	MAX	MIN	MAX
A	0.163	0.189	4.14	4.80
B	0.045	0.055	1.14	1.40
C	0.000	0.010	0.00	0.25
D	0.012	0.028	0.30	0.70
E	0.386	0.409	9.80	10.40
F	0.378	0.417	9.60	10.60
G	0.335	0.358	8.50	9.10
H	0.197	0.236	5.00	6.00
J	0.093	0.108	2.35	2.75
K	0.030	0.035	0.75	0.90

D2PAK (REV: R2)