

## SRAM

## 128 K x 16 SRAM

## HIGH SPEED CMOS SRAM

### FEATURES

- Fast access times : 10, 12, and 15ns
- Fast  $\overline{OE}$  access times : 5, 6, and 7ns
- Single +3.3V  $\pm$  0.3V power supply
- Fully static -- no clock or timing strobes necessary
- All inputs and outputs are TTL-compatible
- Three state outputs
- Center power and ground pins for greater noise immunity
- Easy memory expansive with  $\overline{CE}$  and  $\overline{OE}$  options
- Automatic  $\overline{CE}$  power down
- High-performance, low-power consumption, CMOS triple-poly, double-metal process

### ORDERING INFORMATION

44-pin 400mil SOJ  
 44-pin 400mil TSOP (Typell)

PRODUCT NO.	Access Time (ns)	PACKING TYPE
M21L216128A-10J	10	SOJ
M21L216128A-10T		TSOP
M21L216128A-12J	12	SOJ
M21L216128A-12T		TSOP
M21L216128A-15J	15	SOJ
M21L216128A-15T		TSOP

### GENERAL DESCRIPTION

The M21L216128A is a high speed, low power asynchronous SRAM containing 2,097,152 bits and organized as 131,072 by 16 bits, it is produced by high performance CMOS process.

This device offers center power and ground pins for improved performance and noise immunity. Static design

eliminates the need for external clocks or timing strobes. For increased system flexibility and eliminating bus contention problems, this device offers chip enable ( $\overline{CE}$ ), separate byte enable controls ( $\overline{LB}$  and  $\overline{HE}$ ) and output enable ( $\overline{OE}$ ) with this organization.

### PIN ASSIGNMENT

SOJ Top View

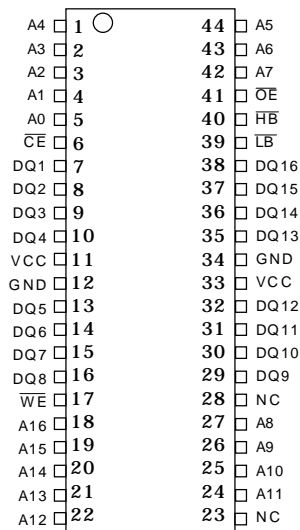

TSOP (Typell) Top View

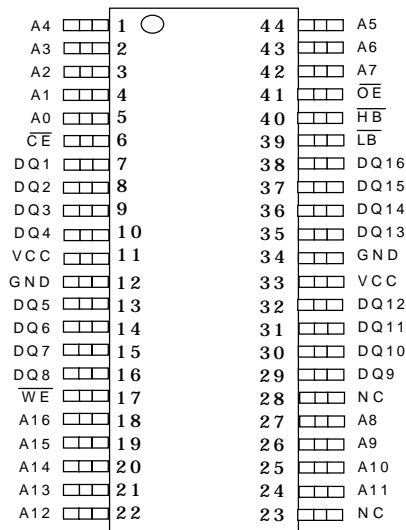

## Block Diagram

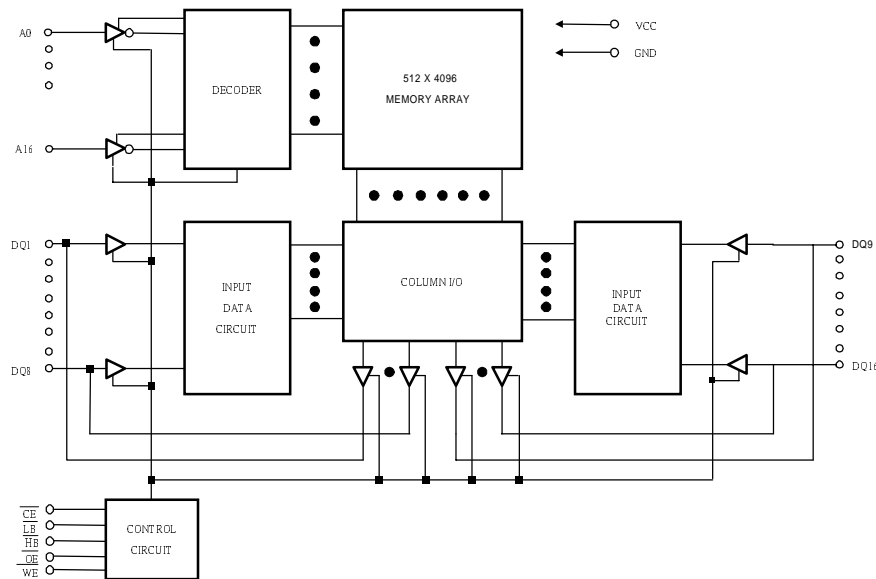

## Pin Descriptions

Pin No.	Symbol	Description
1 - 5, 18 - 22, 24-27, 42 - 44	A0 - A16	Address Inputs
6	$\overline{CE}$	Chip Enable Input
7 - 10, 13 - 16, 29 - 32, 35 - 38	DQ1 - DQ16	Data Inputs/Outputs
17	$\overline{WE}$	Write Enable Input
39	$\overline{LB}$	Lower Byte Enable Input (DQ1 to DQ8)
40	$\overline{HB}$	Higher Byte Enable Input (DQ9 to DQ16)
41	$\overline{OE}$	Output Enable Input
11, 33	VCC	Power
12, 34	GND	Ground
23, 28	NC	No Connection

## ABSOLUTE MAXIMUM RATINGS \*

Voltage on V <sub>cc</sub> Supply Relative to V <sub>ss</sub> ...	-0.5V to +4.6V
V <sub>IN</sub> .....	-0.5V to V <sub>cc</sub> +1.0V
Operating Temperature, T <sub>opr</sub> .....	0 °C to +70 °C
Storage Temperature (plastic) .....	-55 °C to +125 °C
Junction Temperature .....	+125 °C
Power Dissipation .....	1.0W
Short Circuit Output Current .....	50mA

\*Stresses greater than those listed under Absolute Maximum. Ratings may permanent damage to the device. This is a stress rating only and functional operation of the device at these or any other conditions above those indicated in the operational sections of this specification is not implied. Exposure to absolute maximum rating conditions for extended periods may affect reliability.

## DC ELECTRICAL CHARACTERISTICS AND RECOMMENDED OPERATIONS

(All Temperature Ranges ; V<sub>cc</sub> = 3.3V ± 0.3V unless otherwise noted)

DESCRIPTION	CONDITIONS	SYMBOL	MIN	MAX	UNITS	NOTES
Input High (Logic 1) Voltage		V <sub>IH</sub>	2.2	V <sub>cc</sub> +0.5	V	1,2
Input Low (Logic 0) Voltage		V <sub>IL</sub>	-0.5	0.8	V	1,2
Input Leakage Current	0V ≤ V <sub>IN</sub> ≤ V <sub>cc</sub>	I <sub>LI</sub>	-10	10	μA	
Output Leakage Current	Output(s) disable 0V ≤ V <sub>OUT</sub> ≤ V <sub>cc</sub>	I <sub>LO</sub>	-5	5	μA	
Output High Voltage	I <sub>OH</sub> = -4.0 mA	V <sub>OH</sub>	2.4		V	1
Output Low Voltage	I <sub>OL</sub> = 8.0 mA	V <sub>OL</sub>		0.4	V	1
Supply Voltage		V <sub>cc</sub>	3.0	3.6	V	1

DESCRIPTION	CONDITIONS	SYMBOL	MAX			UNITS	NOTES
			-10	-12	-15		
Power Supply Current : Operating	Device selected; $\overline{CE} \leq V_{IL}$ ; V <sub>cc</sub> =MAX; f=f <sub>MAX</sub> ; outputs open	I <sub>cc</sub>	190	160	130	mA	3
TTL Standby	$\overline{CE} \geq V_{IH}$ ; V <sub>cc</sub> =MAX; f=f <sub>MAX</sub>	I <sub>SB1</sub>	35	30	25	mA	
CMOS Standby	$\overline{CE}1 \geq V_{cc}-0.2$ ; V <sub>cc</sub> = MAX; all other inputs ≤ GND +0.2 or ≥ V <sub>cc</sub> -0.2; all inputs static ; f=0	I <sub>SB2</sub>	10	10	10	mA	

## CAPACITANCE

DESCRIPTION	CONDITIONS	SYMBOL	MAX	UNITS	NOTES
Input Capacitance	T <sub>A</sub> =25°C ; f=1 MHz	C <sub>I</sub>	6	pF	4
Input/Output Capacitance(DQ)	V <sub>cc</sub> =3.3V	C <sub>I/O</sub>	8	pF	4

## AC ELECTRICAL CHARACTERISTICS

(Note 5)(All Temperature Ranges;  $V_{CC} = 3.3V \pm 0.3V$ )

DESCRIPTION	SYMBOL	-10		-12		-15		UNIT	Notes
		MIN	MAX	MIN	MAX	MIN	MAX		
<b>Read Cycle</b>									
Read Cycle Time	t <sub>RC</sub>	10		12		15		ns	
Access access time	t <sub>AA</sub>		10		12		15	ns	
Chip Enable access time	t <sub>ACE</sub>		10		12		15	ns	
Output hold from address change	t <sub>OH</sub>	3		4		4		ns	
Chip Enable to output in Low-Z	t <sub>CLZ</sub>	3		4		4		ns	4,7
Chip disable to output in High-Z	t <sub>CHZ</sub>		5		6		7	ns	4,6,7
Output Enable access time	t <sub>OE</sub>		5		6		7	ns	
Output Enable to output in Low-Z	t <sub>OLZ</sub>	0		0		0		ns	
Output Disable to output in High-Z	t <sub>OHZ</sub>		5		6		7	ns	4,6
Byte Enable access time	t <sub>BE</sub>		6		7		8	ns	
Byte Enable to output in Low-Z	t <sub>BLZ</sub>	0		0		0		ns	4,7
Byte disable to output in High-Z	t <sub>BHZ</sub>		5		6		7	ns	4,6,7
<b>Write Cycle</b>									
Write cycle time	t <sub>WC</sub>	10		12		15		ns	
Chip Enable to end of write	t <sub>CW</sub>	8		8		9		ns	
Address valid to end of write, with $\overline{OE}$ HIGH	t <sub>AW</sub>	8		8		9		ns	
Address setup time	t <sub>AS</sub>	0		0		0		ns	
Address hold from end of write	t <sub>WR</sub>	0		0		0		ns	
Write pulse width	t <sub>WP2</sub>	10		10		11		ns	
Write pulse width, with $\overline{OE}$ HIGH	t <sub>WP1</sub>	8		8		9		ns	
Data setup time	t <sub>DW</sub>	5		6		7		ns	
Data hold time	t <sub>DH</sub>	0		0		0		ns	
Write disable to output in Low-Z	t <sub>OW</sub>	3		4		5		ns	4,7
Byte Enable to output in High-Z	t <sub>WHZ</sub>		5		6		7	ns	4,6,7
Byte Enable to end of write	t <sub>BW</sub>	8		8		9		ns	

## TRUTH TABLE

MODE	$\overline{CE}$	$\overline{WE}$	$\overline{OE}$	$\overline{LE}$	$\overline{HE}$	DQ1-DQ8	DQ9-DQ16	POWER
LOW BYTE READ (DQ1-DQ8)	L	H	L	L	H	Q	HIGH-Z	ACTIVE
HIGH BYTE READ (DQ9-DQ16)	L	H	L	H	L	HIGH-Z	Q	ACTIVE
WORD READ (DQ1-DQ16)	L	H	L	L	L	Q	Q	ACTIVE
LOW BYTE WRITE (DQ1-DQ8)	L	L	X	L	H	D	HIGH-Z	ACTIVE
HIGH BYTE WRITE (DQ9-DQ16)	L	L	X	H	L	HIGH-Z	D	ACTIVE
WORD WRITE (DQ1-DQ16)	L	L	X	L	L	D	D	ACTIVE
OUTPUT DISABLE	L	X	X	H	H	HIGH-Z	HIGH-Z	ACTIVE
	L	H	H	X	X	HIGH-Z	HIGH-Z	ACTIVE
STANDBY	H	X	X	X	X	HIGH-Z	HIGH-Z	STANDBY

## AC TEST CONDITIONS

Input plus levels	0V to 3.0V
Input rise and fall times	1.5ns
Input timing reference levels	1.5V
Output reference levels	1.5V
Output load	See Figures 1 and 2

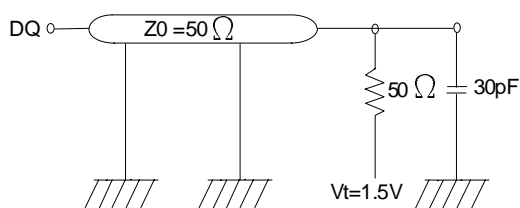

Fig.1 OUTPUT LOAD EQUIVALENT

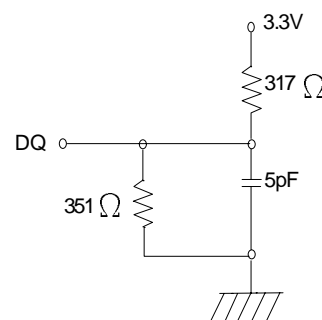

Fig.2 OUTPUT LOAD EQUIVALENT

**NOTES**

1. All voltages referenced to GND (VSS).
2. Overshoot :  $V_{IH} \leq +6.0V$  for  $t \leq t_{RC} / 2$ .  
Undershoot :  $V_{IL} \leq -2.0V$  for  $t \leq t_{RC} / 2$ .
3.  $I_{CC}$  is given without output current.  $I_{CC}$  increases with greater output loading and faster cycle times.
4. This parameter is sampled.
5. Test conditions as specified with the output loading as shown in Fig. 1 unless otherwise noted.
6. Output loading is specified with  $C_L=5pF$  as in Fig.2. Transition is measured  $\pm 500mV$  from steady static voltage.
7. At any give temperature and voltage conditions,  $t_{CHZ}$  is less than  $t_{CLZ}$  and  $t_{WHZ}$  is less than  $t_{OW}$
8.  $\overline{WE}$  is High for Read cycle.
9. Device is continuously selected. Chip enable and output enables are held in their active state.
10. Address valid prior to, or coincident with, latest occurring chip enable.
11.  $t_{RC}$ =Read Cycle Time.
12. Chip Enable and Write Enable can initiate and terminate a Write cycle.
13. Capacitance derating applies to capacitance different from the load capacitance shown in Fig. 1.

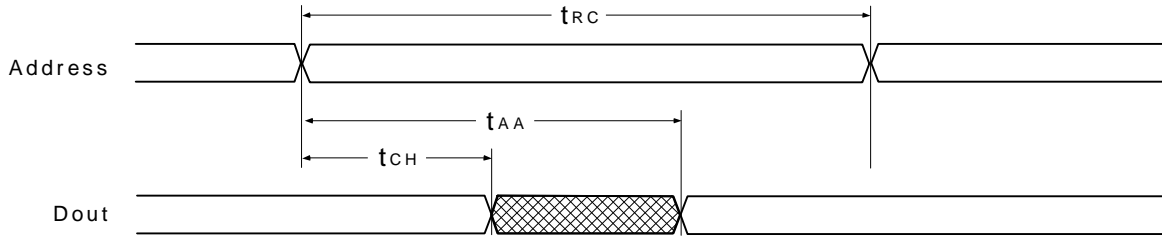

**Timing Waveforms**

**Read Cycle 1<sup>(8,9)</sup>**

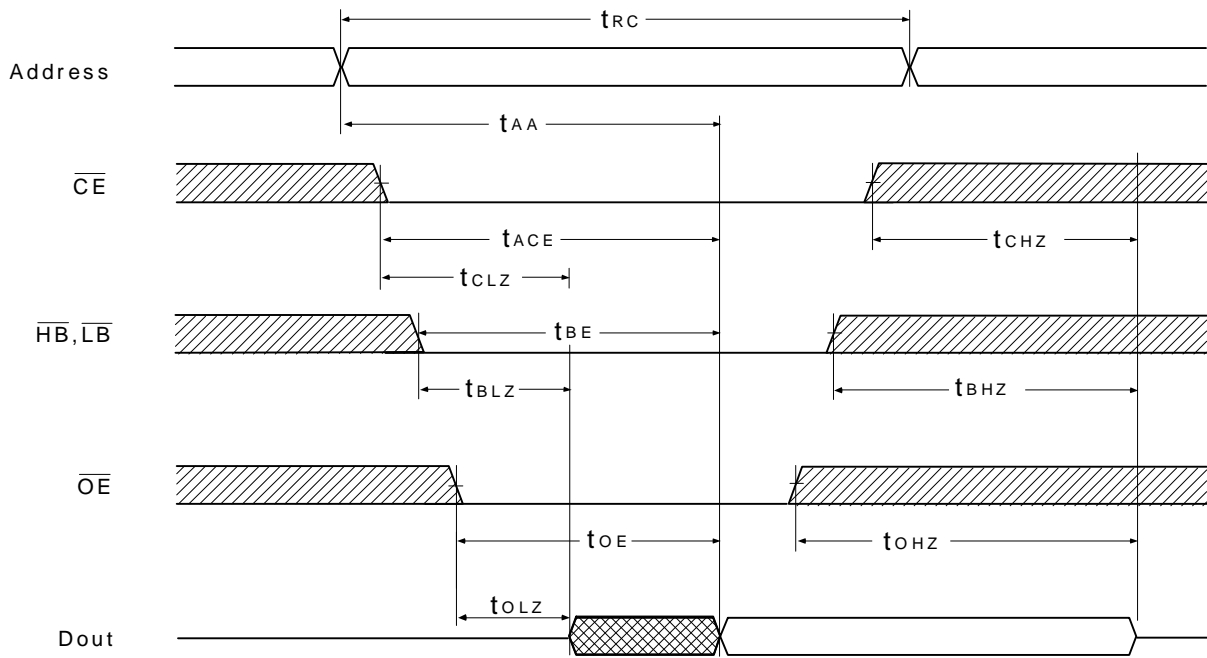

**Read Cycle 2<sup>(7, 8, 9, 10)</sup>**



 : DON'T CARE  
 : UNDEFINED

Timing Waveforms (continued)

Write Cycle 1<sup>(7, 12, 13)</sup>

(Write Enable Controlled with Output Enable  $\overline{OE}$  active LOW)

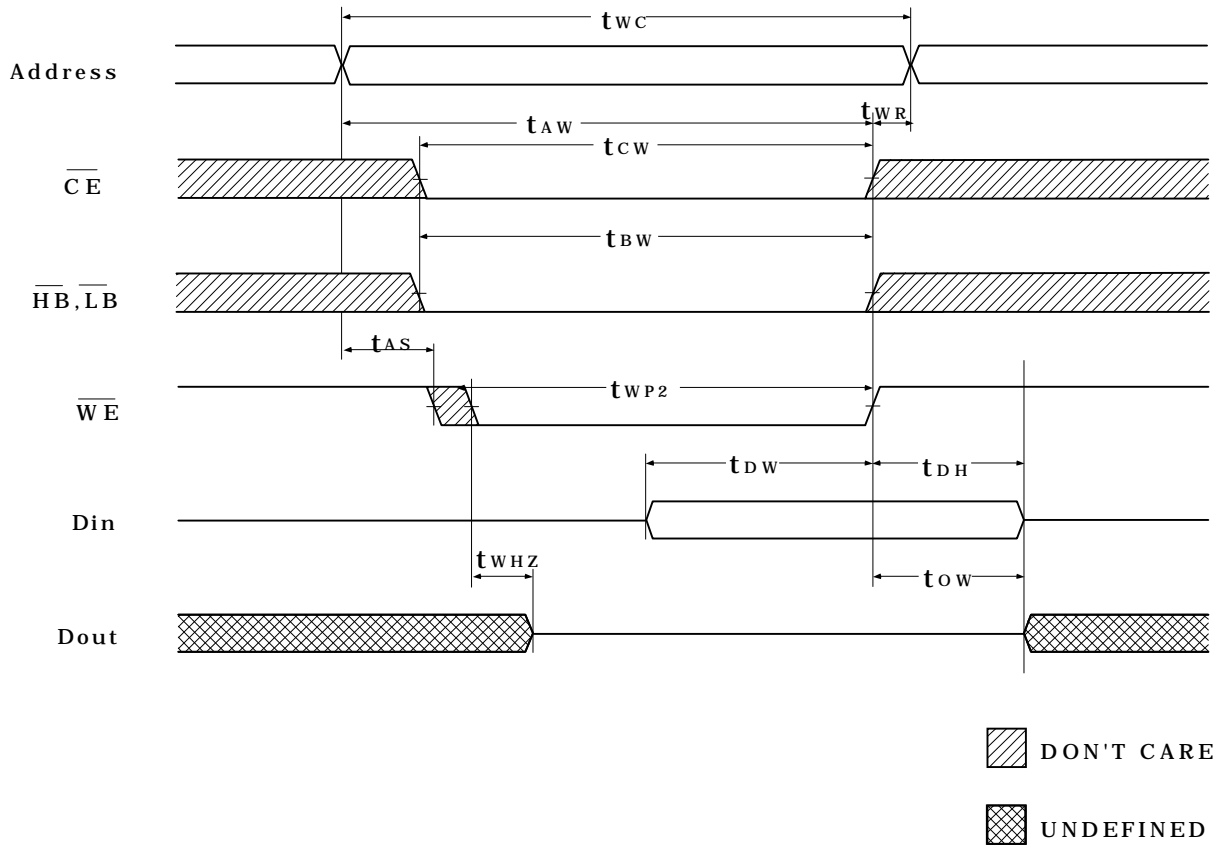



Timing Waveforms (continued)

Write Cycle 2<sup>(12, 13)</sup>

(Write Enable Controlled with Output Enable  $\overline{OE}$  active HIGH)

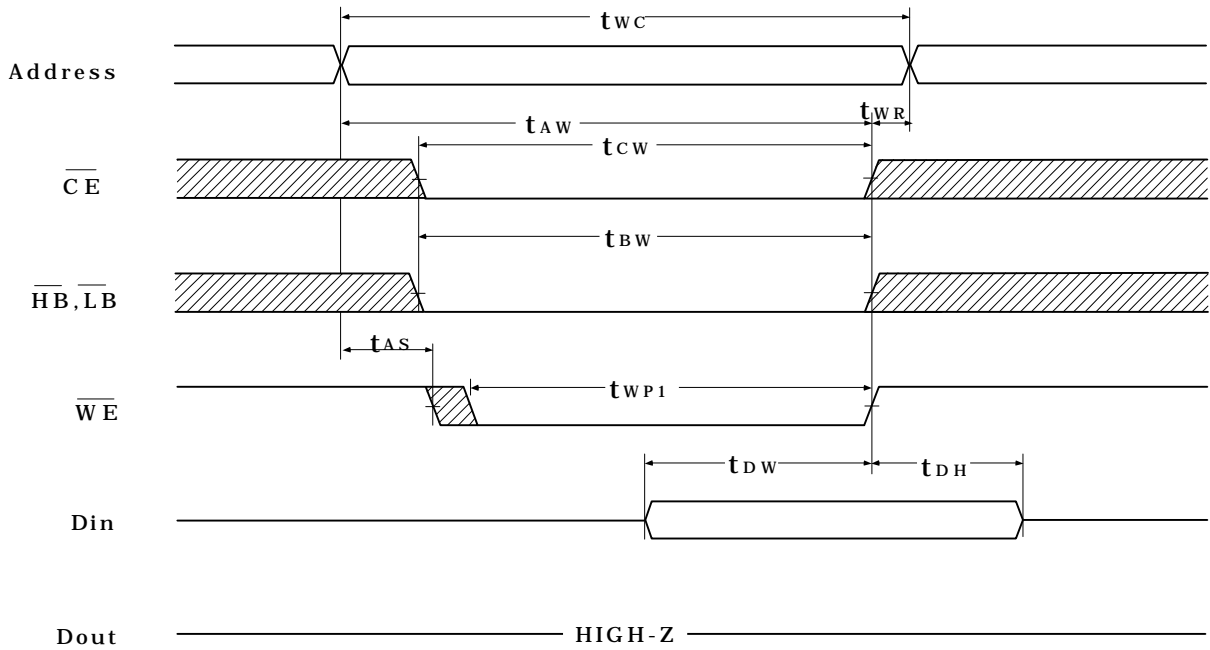

 DON'T CARE

 UNDEFINED

Timing Waveforms (continued)

Write Cycle 3<sup>(12, 13)</sup>

(Chip Enable Controlled)

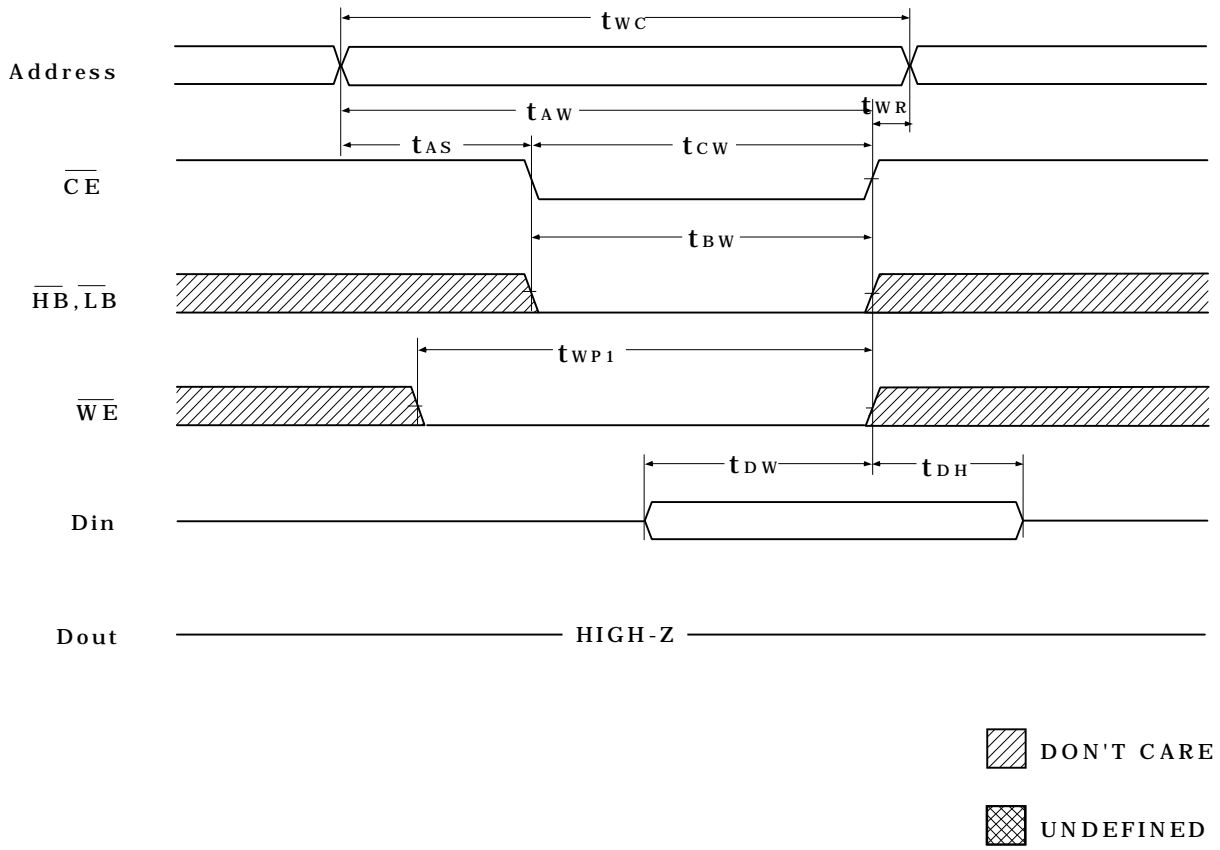

## Timing Waveforms (continued)

### Write Cycle 4<sup>(12, 13)</sup>

#### (Byte Enable Controlled)

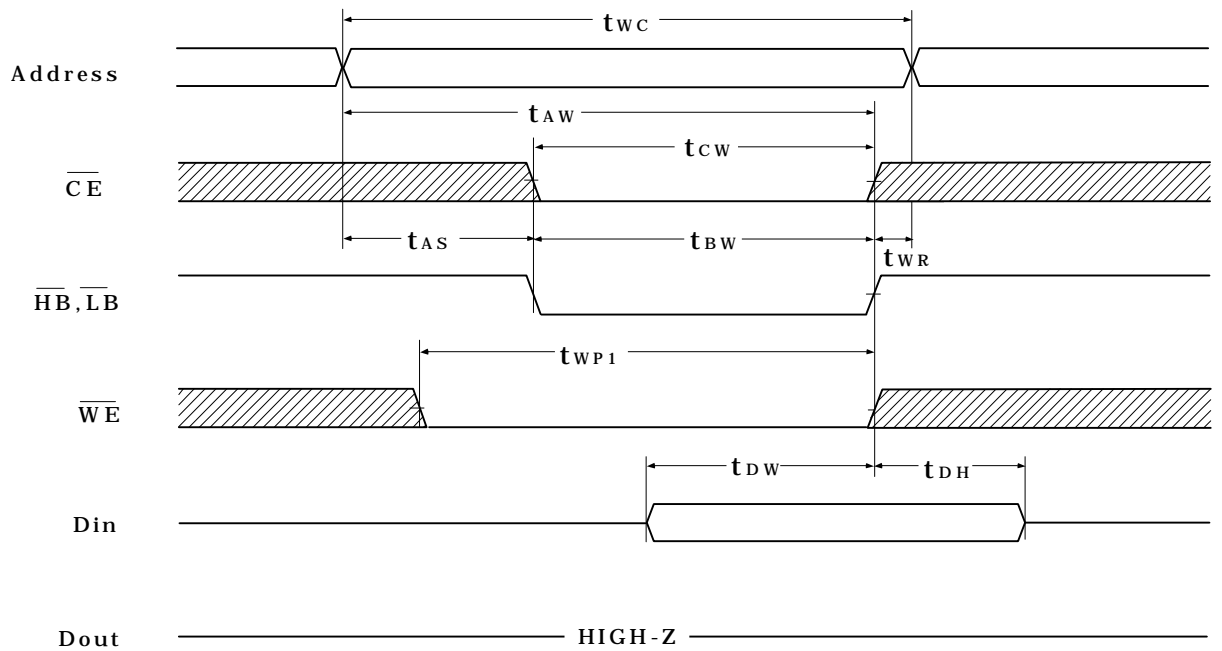

 DON'T CARE

 UNDEFINED

**PACKING**  
44-LEAD

**DIMENSIONS**  
SOJ

SRAM(400mil)

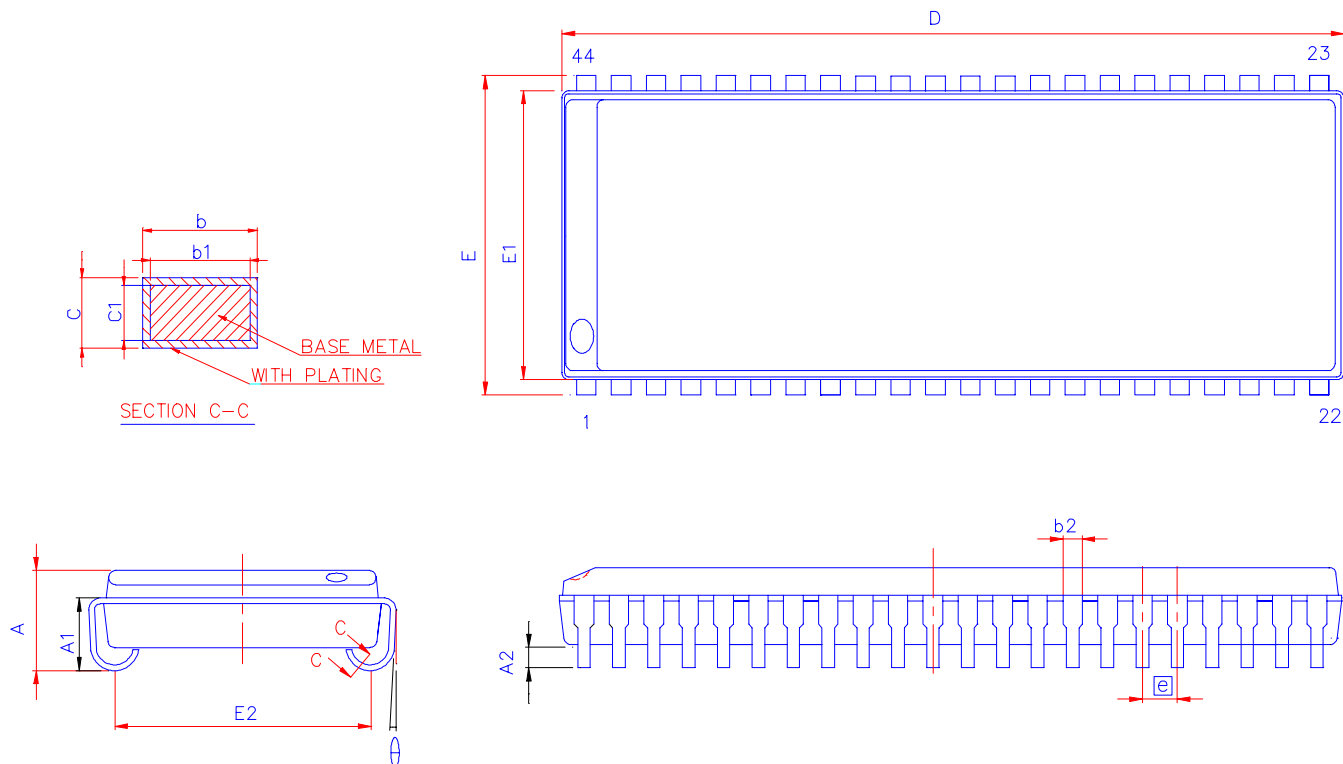

SYMBOL	DIMENSION ( INCH )			DIMENSION ( MM )		
	MIN	NOM	MAX	MIN	NOM	MAX
A	0.128	0.138	0.148	3.25	3.51	3.76
A1	0.082	-	-	2.08	-	-
A2	0.025	-	-	0.60	-	-
b	0.015	-	0.020	0.38	-	0.51
b1	0.015	-	0.018	0.38	-	0.46
c	0.007	-	0.013	0.18	-	0.21
c1	0.007	0.008	0.011	0.18	0.20	0.28
D	1.120	1.125	1.130	28.45	28.58	28.70
E	0.435	0.440	0.445	11.05	11.18	11.30
E1	0.394	0.400	0.405	10.01	10.16	10.29
$\theta$	0°		10°	0°		10°
e	0.050BSC			1.27 BSC		

PACKING DIMENSIONS  
 44-LEAD TSOP(II) SRAM(400mil)

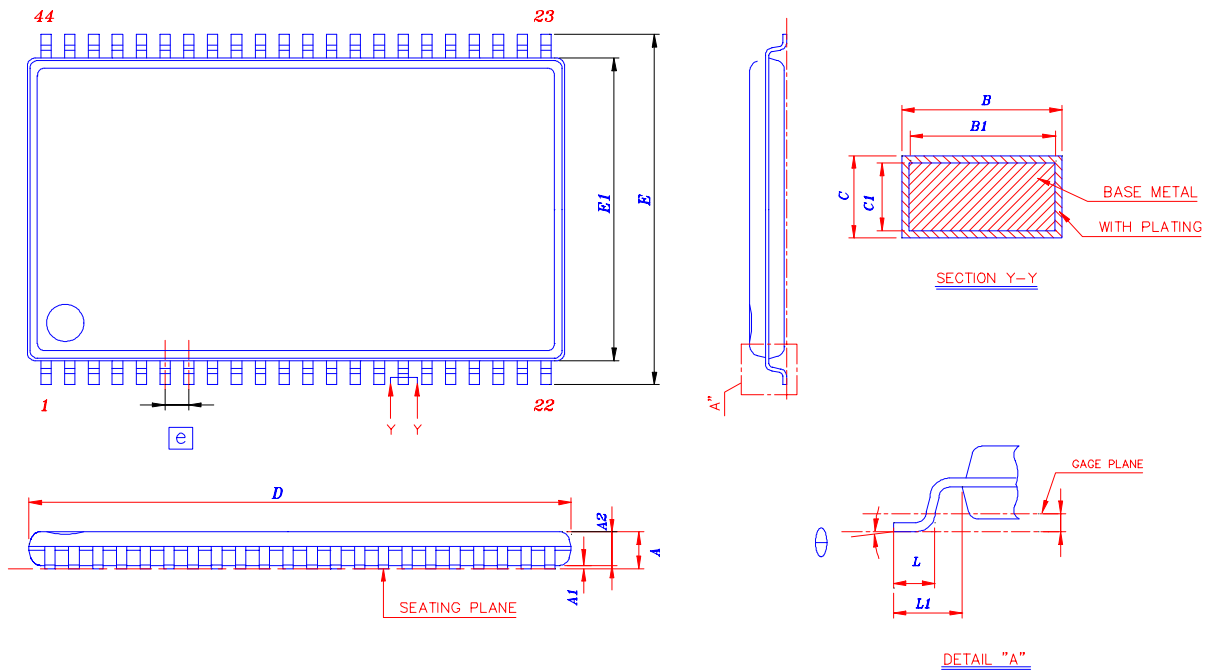

Symbol	Dimension in mm			Dimension in inch		
	Min	Norm	Max	Min	Norm	Max
A	—	—	1.20	—	—	0.047
A1	0.05	—	0.15	0.002	—	0.006
A2	0.95	1.00	1.05	0.037	0.039	0.042
B	0.30	—	0.45	0.012	—	0.018
B1	0.30	0.35	0.40	0.012	0.014	0.016
C	0.12	—	0.21	0.005	—	0.008
C1	0.10	—	0.16	0.004	—	0.006
D	18.28	18.41	18.54	0.720	0.725	0.730
ZD	0.805 REF			0.0317 REF		
E	11.56	11.76	11.96	0.455	0.463	0.471
E1	10.03	10.16	10.29	0.395	0.400	0.4
L	0.40	0.59	0.69	0.016	0.023	0.027
L1	0.80 REF			0.031 REF		
e	0.80 BSC			0.0315 BSC		
θ	0°	—	8°	0°	—	8°

**Important Notice**

All rights reserved.

No part of this document may be reproduced or duplicated in any form or by any means without the prior permission of ESMT.

The contents contained in this document are believed to be accurate at the time of publication. ESMT assumes no responsibility for any error in this document, and reserves the right to change the products or specification in this document without notice.

The information contained herein is presented only as a guide or examples for the application of our products. No responsibility is assumed by ESMT for any infringement of patents, copyrights, or other intellectual property rights of third parties which may result from its use. No license, either express, implied or otherwise, is granted under any patents, copyrights or other intellectual property rights of ESMT or others.

Any semiconductor devices may have inherently a certain rate of failure. To minimize risks associated with customer's application, adequate design and operating safeguards against injury, damage, or loss from such failure, should be provided by the customer when making application designs.

ESMT's products are not authorized for use in critical applications such as, but not limited to, life support devices or system, where failure or abnormal operation may directly affect human lives or cause physical injury or property damage. If products described here are to be used for such kinds of application, purchaser must do its own quality assurance testing appropriate to such applications.