

FEATURES

- Excellent Linearity
- High Responsivity
- Low Dark Current
- Dielectric Passivation
- 100% Purge Burn-in
- Planar Structure

APPLICATIONS

- Analog Optical Receivers to 3GHz
- Forward Path CATV Optical Receivers
- FTTH Receivers



PD070-HL2-5xx
SC Receptacle



PD070-HL2-5xx
ST Receptacle



PD070-HL2-3xx
SC/APC Pigtail



PD070-HL2-5xx
FC Receptacle

PRODUCT DESCRIPTION

The PD070-HL2 is a high performance, InGaAs photodiode with a photosensitive region 70 μ m in diameter. It has been specifically designed for low noise, high linearity analog optical receivers operating to 3GHz. Planar semiconductor design and dielectric passivation provide low noise performance.

Reliability is assured by hermetic sealing and 100% purge burn-in (0200°C, 15 hours, Vr = 20V). The device can be either pigtailed with SC, FC or ST connectors (UPC or APC) or mounted in an SC, ST or FC receptacle. Custom packages are also available.

ELECTRICAL CHARACTERISTICS

Table 1: Electrical Specifications

PARAMETER	MIN	TYP	MAX	UNIT
Dark Current (I _D)	-	0.1	1.0	nA
Capacitance ⁽¹⁾	-	0.6	0.7	pF
Responsivity at 1310nm	0.80	0.90	-	A/W
Responsivity at 1550nm	0.85	0.95	-	A/W
3dB bandwidth (75 Ω bias)	2800	3300	-	MHz
Single Second Order (SSO) ⁽²⁾	-	-75	-70	dBc
Single Triple Beat (STB) ⁽²⁾	-	-85	-80	dBc
Optical Return Loss (Pigtail using SMF-28)	50	55	-	dB
Optical Return Loss (Receptacle, APC connector)	40	45	-	dB
Operating voltage	-	5	20	V

(1) 5V bias voltage

(2) SSO and STB measurements to 860MHz using 2 and 3 tones at 40% OMI, 0dBm optical input, 1310nm, 12V bias.

PD070-HL2

Table 2: Absolute Maximum Ratings

PARAMETER	MIN	MAX	UNIT
Forward Current	-	5	mA
Reverse Current	-	250	μA
Reverse Voltage	-	30	V
Optical input power	-	5	mW
Operating Case Temperature	-40	+85	°C
Storage Temperature	-40	+85	°C
Soldering temperature (10 seconds)	-	+250	°C

Stresses in excess of the absolute ratings may cause permanent damage. Functional operation is not implied under these conditions. Exposure to absolute ratings for extended periods of time may adversely affect reliability.

PIN LOCATIONS – Standard

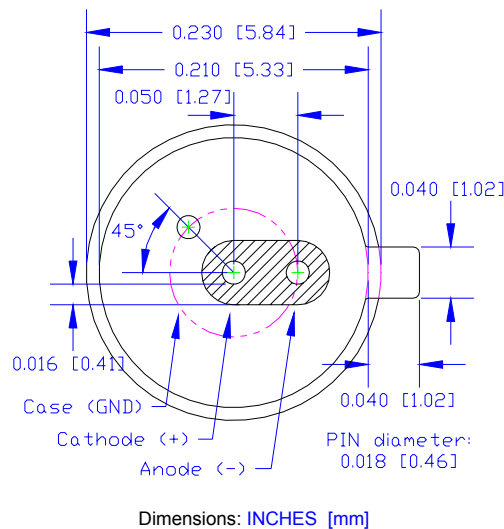

ORDERING INFORMATION

Table 3: Standard

Part Number	Options
PD070-HL2-300	SC/APC pigtail, 1 meter SMF-28 fiber, 3 pin
PD070-HL2-520	SC/APC receptacle, 3 pin

Table 4: Custom

Part Number	Options
PD070-HL2-3xx	Number of pins: 2, 3 Fiber length: 0.5 meter, 1.0 meter Fiber type: Single mode (SMF-28) or custom supplied Connector Type: SC, ST or FC. APC or UPC
PD070-HL2-5xx	Number of pins: 2, 3 Connector Type: SC, ST or FC. Aligned for APC or UPC

Please contact Anadigics for the specific part number and pinout that suits your needs

ANADIGICS, Inc.

829 Flynn Road
Camarillo, California 93012, U.S.A.
Tel: +1 (805) 445-4500
Fax: +1 (805) 445-4502
URL: <http://www.anadigics.com>
E-mail: Mktg@anadigics.com

IMPORTANT NOTICE

ANADIGICS, Inc. reserves the right to make changes to its products or discontinue any product at any time without notice. The product specifications contained in Advanced Product Information sheets and Preliminary Data sheets are subject to change prior to a product's formal introduction. Information in Data Sheets have been carefully checked and are assumed to be reliable; however, ANADIGICS assumes no responsibility for inaccuracies. ANADIGICS strongly urges customers to verify that the information they are using is current before placing orders.

WARNING

ANADIGICS products are not intended for use in life support appliances, devices, or systems. Use of an ANADIGICS product in any such application without written consent is prohibited.