

AN1571

Digital Blood Pressure Meter

Prepared by: C.S. Chua and Siew Mun Hin
 Sensor Application Engineering
 Singapore, A/P

INTRODUCTION

This application note describes a Digital Blood Pressure Meter concept which uses an integrated pressure sensor, analog signal-conditioning circuitry, microcontroller hardware/software and a liquid crystal display. The sensing system reads the cuff pressure (CP) and extracts the pulses for analysis and determination of systolic and diastolic pressure. This design uses a 50 kPa integrated pressure sensor (Motorola P/N: MPX5050GP) yielding a pressure range of 0 mmHg to 300 mmHg.

CONCEPT OF OSCILLOMETRIC METHOD

This method is employed by the majority of automated non-invasive devices. A limb and its vasculature are compressed by an encircling, inflatable compression cuff. The blood pressure reading for systolic and diastolic blood pressure values are read at the parameter identification point.

The simplified measurement principle of the oscillometric method is a measurement of the amplitude of pressure change in the cuff as the cuff is inflated from above the systolic pressure. The amplitude suddenly grows larger as the pulse breaks through the occlusion. This is very close to systolic pressure. As the cuff pressure is further reduced, the pulsation increase in amplitude, reaches a maximum and then diminishes rapidly. The index of diastolic pressure is taken where this rapid transition begins. Therefore, the systolic

blood pressure (SBP) and diastolic blood pressure (DBP) are obtained by identifying the region where there is a rapid increase then decrease in the amplitude of the pulses respectively. Mean arterial pressure (MAP) is located at the point of maximum oscillation.

HARDWARE DESCRIPTION AND OPERATION

The cuff pressure is sensed by Motorola's integrated pressure X-ducer™. The output of the sensor is split into two paths for two different purposes. One is used as the cuff pressure while the other is further processed by a circuit. Since MPX5050GP is signal-conditioned by its internal op-amp, the cuff pressure can be directly interfaced with an analog-to-digital (A/D) converter for digitization. The other path will filter and amplify the raw CP signal to extract an amplified version of the CP oscillations, which are caused by the expansion of the subject's arm each time pressure in the arm increases during cardiac systole.

The output of the sensor consists of two signals; the oscillation signal (≈ 1 Hz) riding on the CP signal (≤ 0.04 Hz). Hence, a 2-pole high pass filter is designed to block the CP signal before the amplification of the oscillation signal. If the CP signal is not properly attenuated, the baseline of the oscillation will not be constant and the amplitude of each oscillation will not have the same reference for comparison. Figure 1 shows the oscillation signal amplifier together with the filter.

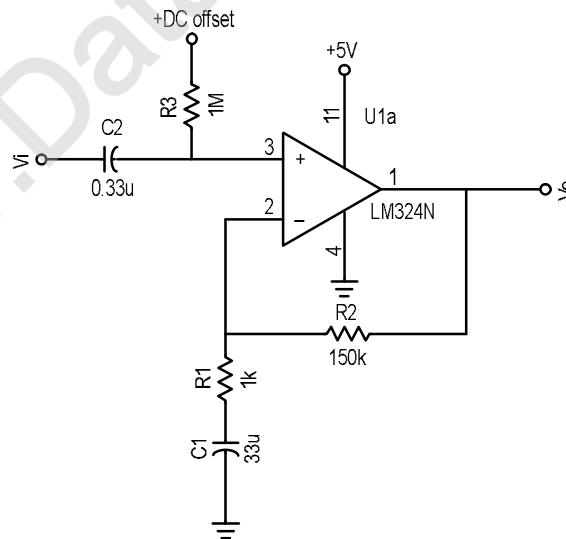

Figure 1. Oscillation Signal Amplifier

Freescale Semiconductor, Inc.

www.DataSheet4U.com

The filter consists of two RC networks which determine two cut-off frequencies. These two poles are carefully chosen to ensure that the oscillation signal is not distorted or lost. The

two cut-off frequencies can be approximated by the following equations. Figure 2 describes the frequency response of the filter. This plot does not include the gain of the amplifier.

$$f_{P1} = \frac{1}{2\pi R_1 C_1}$$

$$f_{P2} = \frac{1}{2\pi R_3 C_2}$$

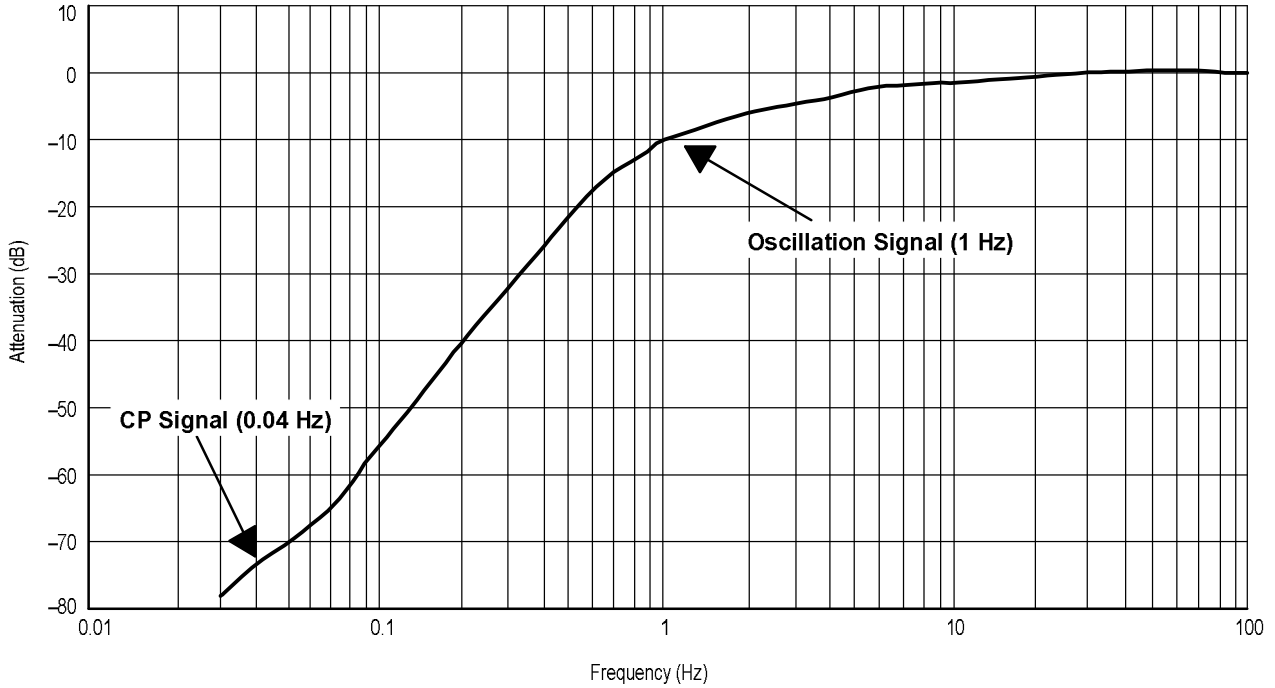

Figure 2. Filter Frequency Response

The oscillation signal varies from person to person. In general, it varies from less than 1 mmHg to 3 mmHg. From the transfer function of MPX5050GP, this will translate to a voltage output of 12 mV to 36 mV signal. Since the filter gives an attenuation of 10 dB to the 1 Hz signal, the oscillation signal becomes 3.8 mV to 11.4 mV respectively. Experiments

indicate that, the amplification factor of the amplifier is chosen to be 150 so that the amplified oscillation signal is within the output limit of the amplifier (5 mV to 3.5 V). Figure 3(a) shows the output from the pressure sensor and Figure 3(b) shows the extracted oscillation signal at the output of the amplifier.

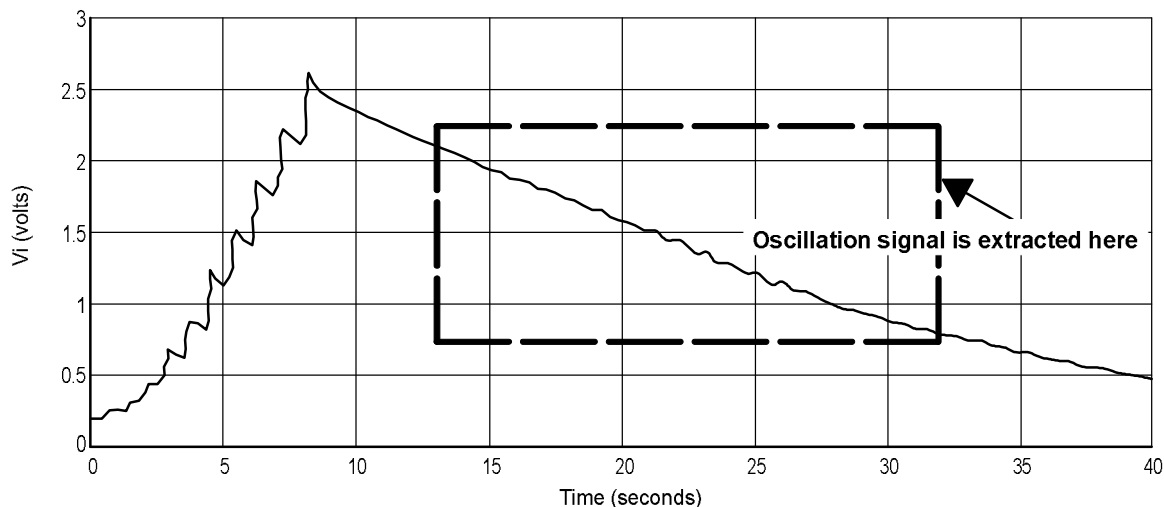

Figure 3. CP signal at the output of the pressure sensor

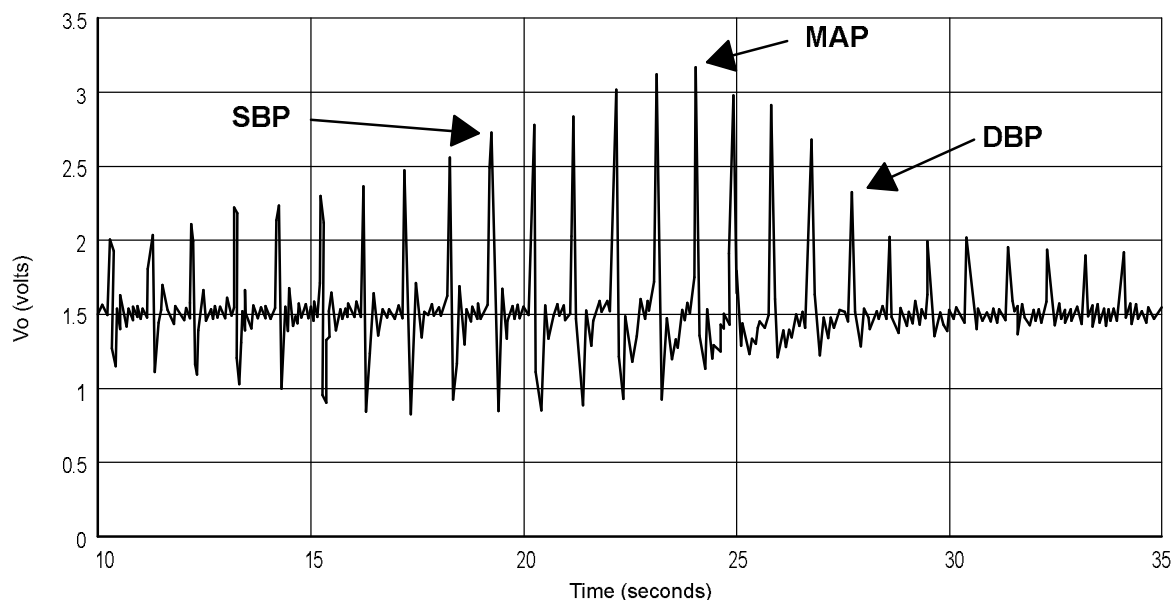

Figure 3b. Extracted oscillation signal at the output of amplifier

Referring to the schematic, Figure 4, the MPX5050GP pressure sensor is connected to PORT D bit 5 and the output of the amplifier is connected to PORT D bit 6 of the microcontroller. This port is an input to the on-chip 8-bit analog-to-digital (A/D) converter. The pressure sensor provides a signal output to the microprocessor of approximately 0.2 Vdc at 0 mmHg to 4.7 Vdc at 375 mmHg of applied pressure whereas the amplifier provides a signal from 0.005 V to 3.5 V. In order to maximize the resolution, separate voltage references should be provided for the A/D instead of using the 5 V supply. In this example, the input range of the A/D converter is set at approximately 0 Vdc to 3.8 Vdc. This compresses the range of the A/D converter around 0 mmHg to 300 mmHg to maximize the resolution; 0 to 255 counts is the range of the A/D converter. V_{RH} and V_{RL} are the reference voltage inputs to the A/D converter. The resolution is defined by the following:

$$\text{Count} = [(V_{Xdcr} - V_{RL}) / (V_{RH} - V_{RL})] \times 255$$

The count at 0 mmHg = $[(0.2 - 0) / (3.8 - 0)] \times 255 \approx 14$

The count at 300 mmHg = $[(3.8 - 0) / (3.8 - 0)] \times 255 \approx 255$

Therefore the resolution = $255 - 14 = 241$ counts. This translates to a system that will resolve to 1.24 mmHg.

The voltage divider consisting of R5 and R6 is connected to the +5 volts powering the system. The output of the pressure sensor is ratiometric to the voltage applied to it. The pressure sensor and the voltage divider are connected to a common supply; this yields a system that is ratiometric. By nature of this

ratiometric system, variations in the voltage of the power supplied to the system will have no effect on the system accuracy.

The liquid crystal display (LCD) is directly driven from I/O ports A, B, and C on the microcontroller. The operation of a LCD requires that the data and backplane (BP) pins must be driven by an alternating signal. This function is provided by a software routine that toggles the data and backplane at approximately a 30 Hz rate.

Other than the LCD, there are two more I/O devices that are connected to the pulse length converter (PLM) of the microcontroller; a buzzer and a light emitting diode (LED). The buzzer, which connected to the PLMA, can produce two different frequencies; 122 Hz and 1.953 kHz tones. For instance when the microcontroller encounters certain error due to improper inflation of cuff, a low frequency tone is alarm. In those instance when the measurement is successful, a high frequency pulsation tone will be heard. Hence, different musical tone can be produced to differential each condition. In addition, the LED is used to indicate the presence of a heart beat during the measurement.

The microcontroller section of the system requires certain support hardware to allow it to function. The MC34064P-5 provides an undervoltage sense function which is used to reset the microprocessor at system power-up. The 4 MHz crystal provides the external portion of the oscillator function for clocking the microcontroller and provides a stable base for time based functions, for instance calculation of pulse rate.

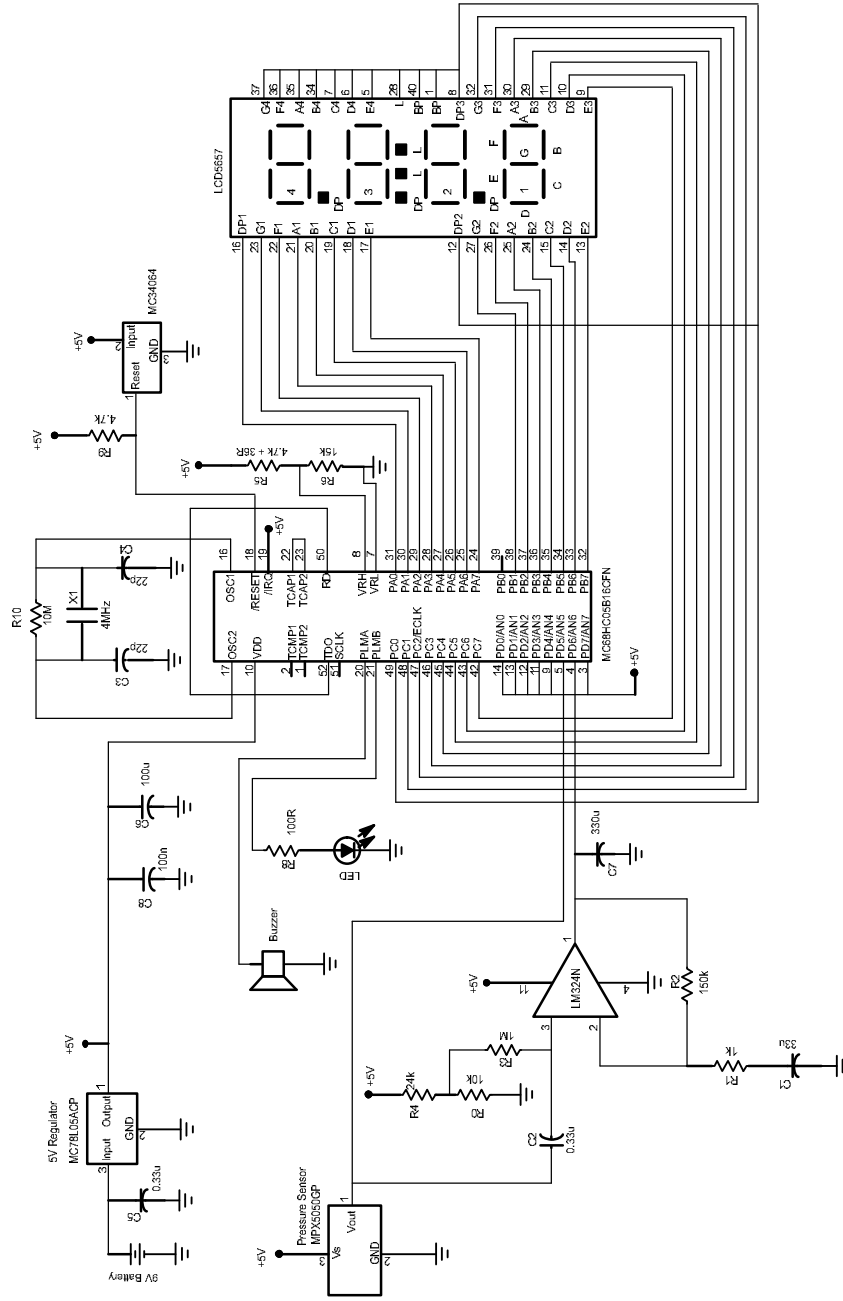

Figure 4. Blood Pressure Meter Schematic Drawing

SOFTWARE DESCRIPTION

Upon system power-up, the user needs to manually pump the cuff pressure to approximately 160 mmHg or 30 mmHg above the previous SBP. During the pumping of the inflation bulb, the microcontroller ignores the signal at the output of the

amplifier. When the subroutine TAKE senses a decrease in CP for a continuous duration of more than 0.75 seconds, the microcontroller will then assume that the user is no longer pumping the bulb and starts to analyze the oscillation signal. Figure 5 shows zoom-in view of a pulse.

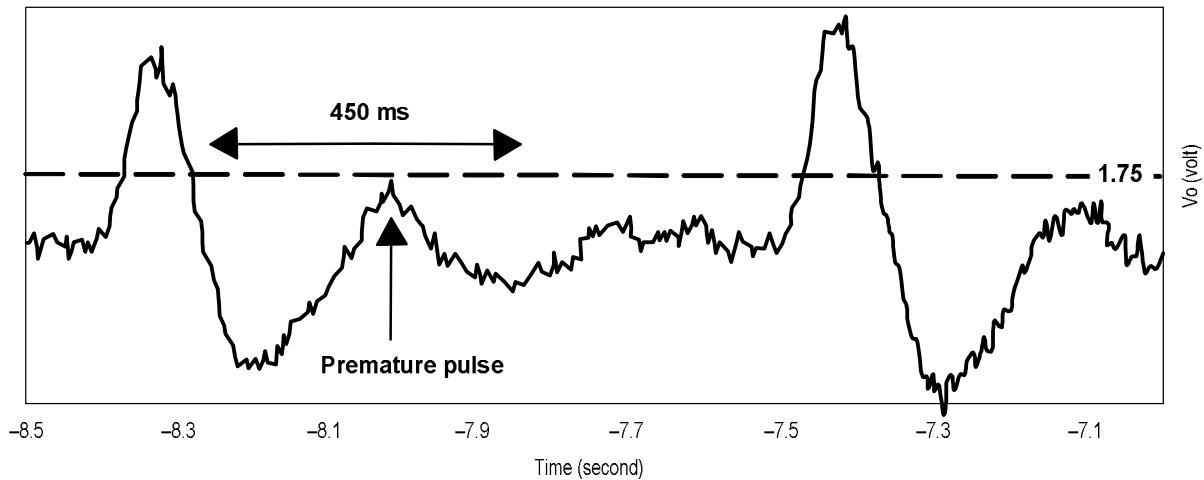

Figure 5. Zoom-in view of a pulse

First of all, the threshold level of a valid pulse is set to be 1.75 V to eliminate noise or spike. As soon as the amplitude of a pulse is identified, the microcontroller will ignore the signal for 450 ms to prevent any false identification due to the presence of premature pulse "overshoot" due to oscillation. Hence, this algorithm can only detect pulse rate which is less than 133 beats per minute. Next, the amplitudes of all the pulses detected are stored in the RAM for further analysis. If the microcontroller senses a non-typical oscillation envelope

shape, an error message ("Err") is output to the LCD. The user will have to exhaust all the pressure in the cuff before re-pumping the CP to the next higher value. The algorithm ensures that the user exhausts all the air present in the cuff before allowing any re-pumping. Otherwise, the venous blood trapped in the distal arm may affect the next measurement. Therefore, the user has to reduce the pressure in the cuff as soon as possible in order for the arm to recover. Figure 6 is a flowchart for the program that controls the system.

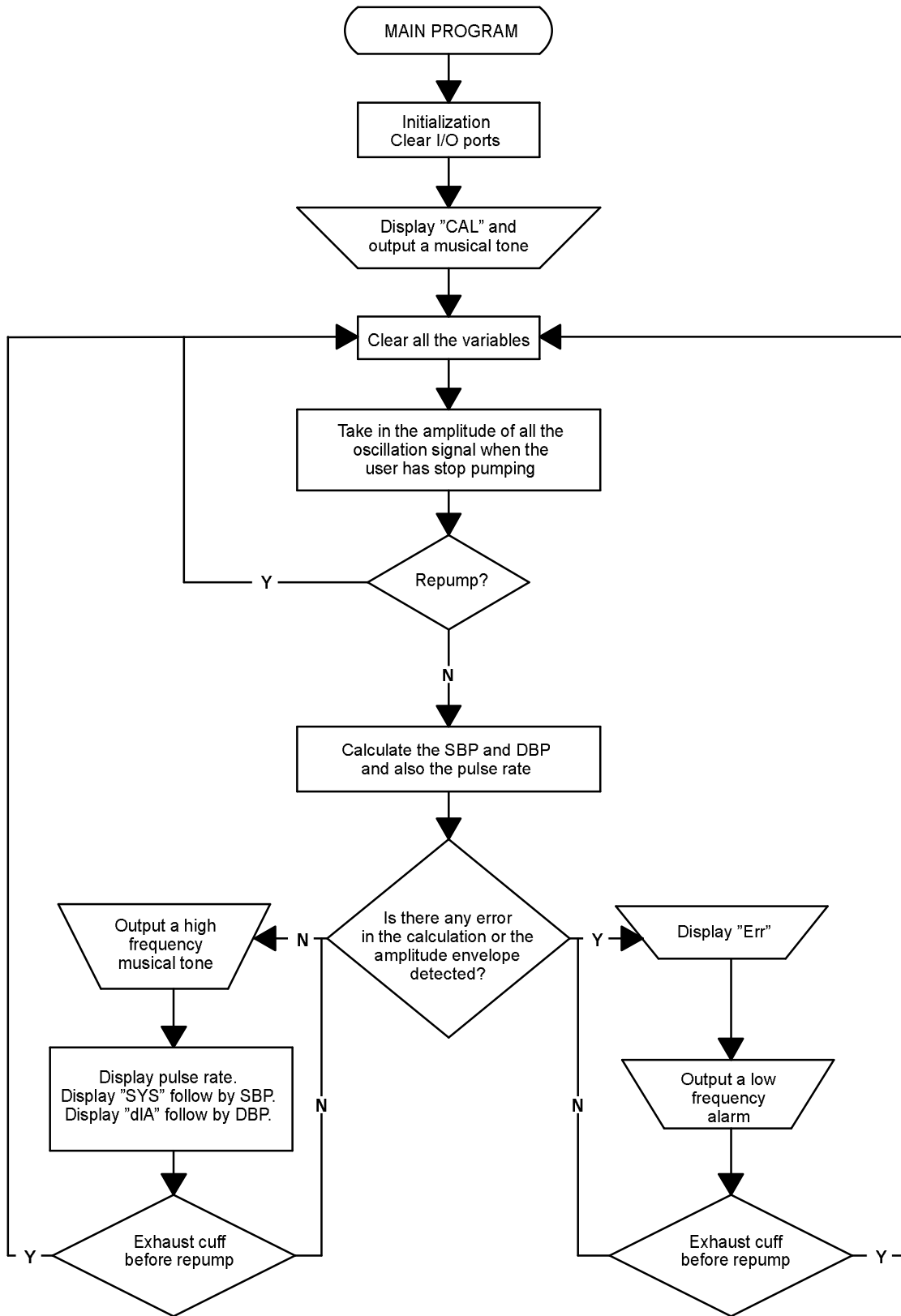

Figure 6. Main program flowchart

SELECTION OF MICROCONTROLLER

Although the microcontroller used in this project is MC68HC05B16, a smaller ROM version microcontroller can also be used. The table below shows the requirement of microcontroller for this blood pressure meter design in this project.

Table 1. Selection of microcontroller

On-chip ROM space	2 kilobytes
On-chip RAM space	150 bytes
2-channel A/D converter (min.)	
16-bit free running counter timer	
LCD driver	
On-chip EEPROM space	32 bytes
Power saving Stop and Wait modes	

CONCLUSION

This circuit design concept may be used to evaluate Motorola pressure sensors used in the digital blood pressure meter. This basic circuit may be easily modified to provide suitable output signal level. The software may also be easily modified to provide better analysis of the SBP and DBP of a person.

REFERENCES

Lucas, Bill (1991). "An Evaluation System for Direct Interface of the MPX5100 Pressure Sensor with a Microprocessor," Motorola Application Note AN1305.

Motorola reserves the right to make changes without further notice to any products herein. Motorola makes no warranty, representation or guarantee regarding the suitability of its products for any particular purpose, nor does Motorola assume any liability arising out of the application or use of any product or circuit, and specifically disclaims any and all liability, including without limitation consequential or incidental damages. "Typical" parameters which may be provided in Motorola data sheets and/or specifications can and do vary in different applications and actual performance may vary over time. All operating parameters, including "Typicals" must be validated for each customer application by customer's technical experts. Motorola does not convey any license under its patent rights nor the rights of others. Motorola products are not designed, intended, or authorized for use as components in systems intended for surgical implant into the body, or other applications intended to support or sustain life, or for any other application in which the failure of the Motorola product could create a situation where personal injury or death may occur. Should Buyer purchase or use Motorola products for any such unintended or unauthorized application, Buyer shall indemnify and hold Motorola and its officers, employees, subsidiaries, affiliates, and distributors harmless against all claims, costs, damages, and expenses, and reasonable attorney fees arising out of, directly or indirectly, any claim of personal injury or death associated with such unintended or unauthorized use, even if such claim alleges that Motorola was negligent regarding the design or manufacture of the part. Motorola and  are registered trademarks of Motorola, Inc. Motorola, Inc. is an Equal Opportunity/Affirmative Action Employer.

Mfax is a trademark of Motorola, Inc.

How to reach us:

USA/EUROPE/Locations Not Listed: Motorola Literature Distribution;
P.O. Box 5405, Denver, Colorado 80217. 303-675-2140 or 1-800-441-2447

JAPAN: Nippon Motorola Ltd.; Tatsumi-SPD-JLDC, 6F Seibu-Butsuryu-Center,
3-14-2 Tatsumi Koto-Ku, Tokyo 135, Japan. 81-3-3521-8315

Mfax™: RMFAX0@email.sps.mot.com – TOUCHTONE 602-244-6609
– US & Canada ONLY 1-800-774-1848

ASIA/PACIFIC: Motorola Semiconductors H.K. Ltd.; 8B Tai Ping Industrial Park,
51 Ting Kok Road, Tai Po, N.T., Hong Kong. 852-26629298

INTERNET: <http://motorola.com/sps>



◆ **For More Information On This Product,
Go to: www.freescale.com**

AN1571/D