

M63154AFP

3-PHASE BRUSHLESS MOTOR DRIVER

REJ03F0025-0100Z

Rev.1.0

Sep.16.2003

Description

M63154AFP is a semiconductor integrated circuit designed for 3 phase brush less motor driver.

Also, this device has the PWM control system for Spindle.

Therefore this device is low power dissipation

This device is good for high rotation motor.

Features

- This IC has PWM output function.
Therefore, this IC is low power dissipation.
- Hall-sensor motor drive function.
- Built-in Thermal Shut Down circuit.

Application

LBP etc.

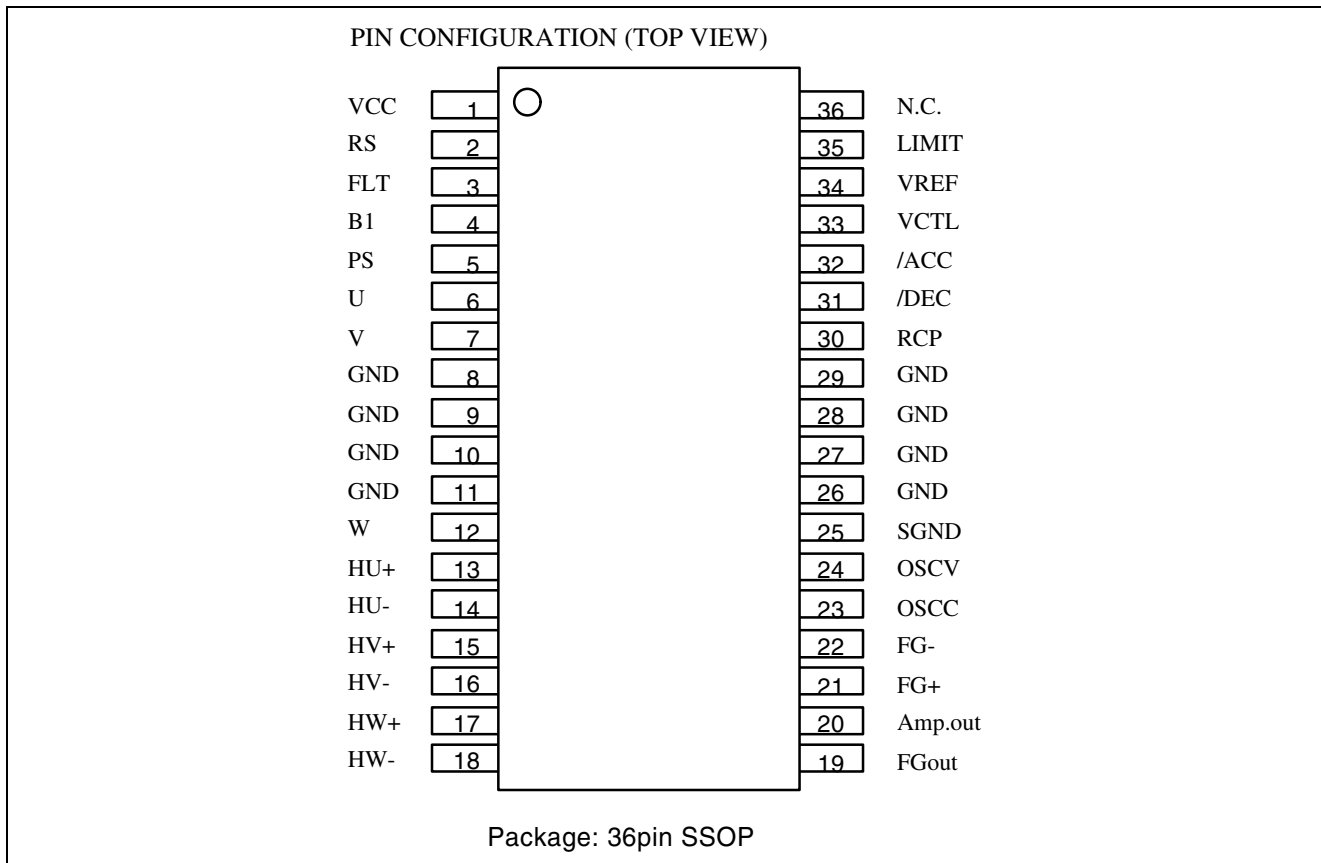

BLOCK DIAGRAM

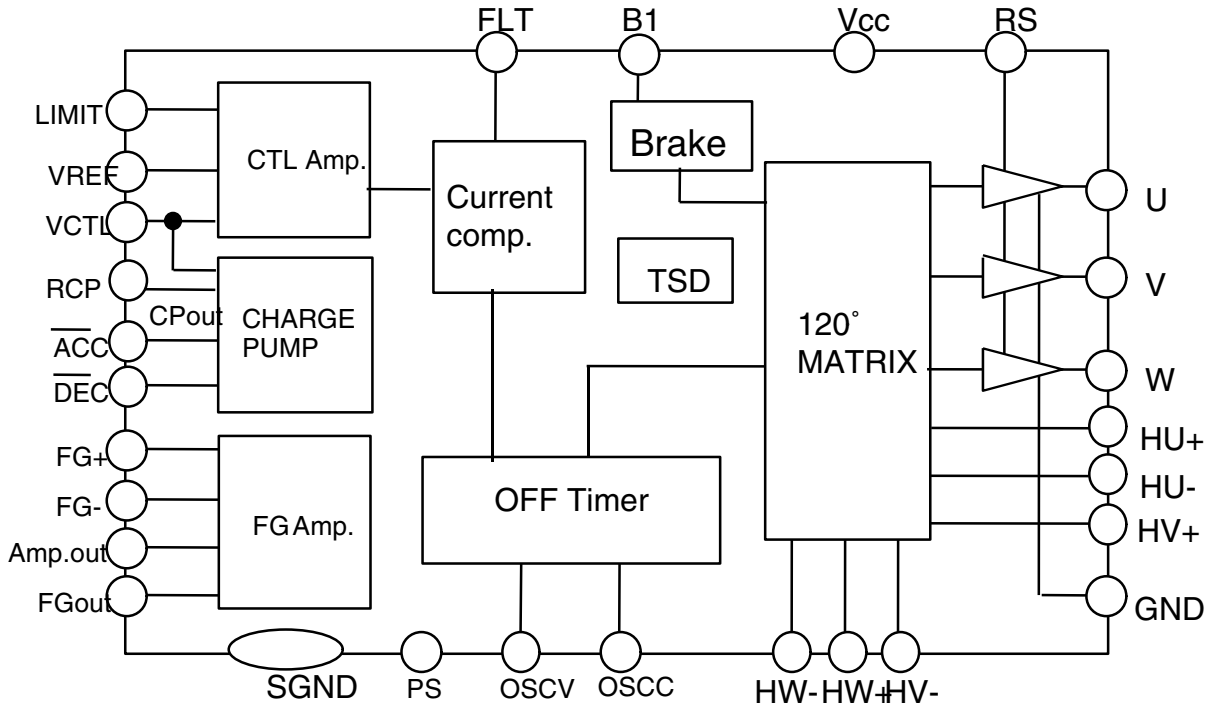

Pin Function

TERMINAL	SYMBOL	TERMINAL FUNCTION	TERMINAL	SYMBOL	TERMINAL FUNCTION
1	Vcc	Power supply	19	FGout	FG comparator output
2	RS	Current sense	20	Amp.out	FG amp. output
3	FLT	Connect to application of filter	21	FG+	FG signal input (+)
4	B1	Short brake switch	22	FG-	FG signal input (-)
5	PS	Power save signal input	23	OSCC	OFF Timer setup -1
6	U	Motor phase U output	24	OSCV	OFF Timer setup -2
7	V	Motor phase V output	25	SGND	GND
8 to 11 26 to 29	GND	Power GND	30	RCP	Charge pump output current setup term.
12	W	Motor phase W output	31	DEC	Deceleration signal input
13	Hu+	Hall sensor signal input (U phase +)	32	ACC	Acceleration signal input
14	Hu-	Hall sensor signal input (U phase -)	33	VCTL	Motor speed control voltage input
15	Hv+	Hall sensor signal input (V phase +)	34	VREF	Reference voltage input
16	Hv-	Hall sensor signal input (V phase -)	35	LIMIT	Current limit set up terminal
17	Hw+	Hall sensor signal input (W phase +)	36	N.C.	N.C
18	Hw-	Hall sensor signal input (W phase -)			

Absolute Maximum Rating (Ta=25°C)

SYMBOL	PARAMETER	CONDITIONS	RATING	UNIT
Vcc	Power supply		30.0	V
Io	Motor output current		1.35	A /PHASE
Pt	Power dissipation	Free Air	1.2	W
Kθ	Thermal derating	Free Air	9.6	mW/°C
Tj	Junction temperature		150	°C
Topr	Operating temperature		-10 to 75	°C
Tstg	Storage temperature		-40 to 125	°C

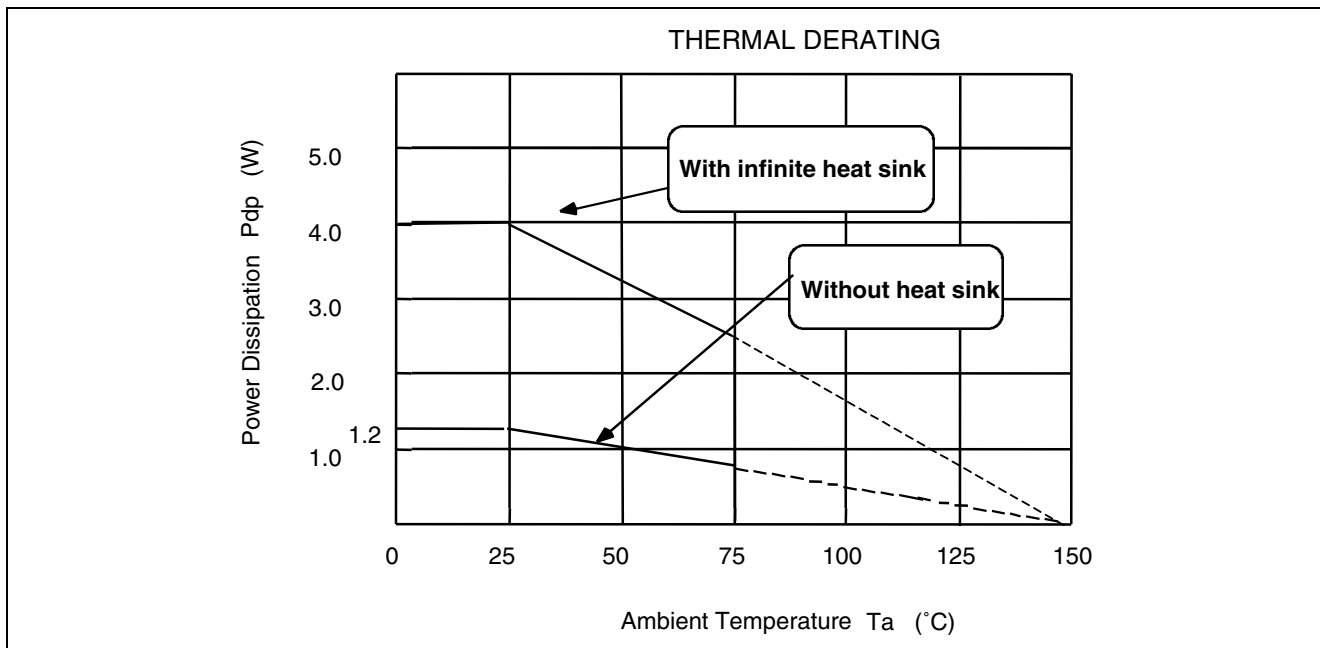

Recommend Operating Conditions ($T_a = 25^\circ\text{C}$)

SYMBOL	PARAMETER	LIMITS			Unit
		Minimum	Typical	Maximum	
Vcc	Power supply	12	24	28	V
Io	Motor output current	—	—	1.2	A

Electrical Characteristics

(Ta=25°C, Vcc=24V unless otherwise noted)

SYMBOL	PARAMETERS	CONDITIONS	LIMITS			UNIT
			MIN.	TYP.	MAX.	
Icc	Supply current		—	22.0	30.0	mA
Ips	Power save current		—	300	600	μA
VSAT	Saturation voltage	at load current 800mA total of top and bottom side	—	2.2	3.3	V
GIO	Control gain		0.425	0.5	0.575	V/V
VHA2	Hall sensor amp. common mode input range		1.5		Vcc-2	V
VHA3	Hall sensor amp. input signal level		100	—	—	mVpp
IHA	Hall sensor amp.input current		—	0.5	4.0	μA
VREF	Reference voltage input range		1.5	—	4.2	V
VCTLin	Speed control voltage input range		0	—	5.5	V
IACCH	ACC terminal input current-H	ACC=5V	-1.0	—	+1.0	μA
IACCL	ACC terminal input current-L	ACC=0V	-50	-10	—	μA
IDECH	DEC terminal input current-H	DEC=5V	—	250	500	μA
IDECL	DEC terminal input current-L	DEC=0V	-50	-10	—	μA
VTACC	ACC terminal threshold voltage		0.8	1.4	2.0	V
VTDEC	DEC terminal threshold voltage		0.8	1.4	2.0	V
TCPin	acceleration and deceleration minimum pulse width	Minimum pulse width on the ACC and DEC pins that sets up the sink or source for the accelerating or decelerating current (±220 μA).	200	-	-	ns
ISS	Output current at acceleration mode	ACC=L, DEC=H, VCTL=2V, RCP-GND=12.5kΩ	-220	-200	-180	μA
ISD	at deceleration mode Output current	ACC=H, DEC=L, VCTL=2V, RCP-GND=12.5kΩ	180	200	220	μA
ICTL	VCTL terminal input current-L	ACC=DEC=HorL, VCTL=3V	-50	0	50	nA

Electrical Characteristics

(Ta=25°C, Vcc=24V unless otherwise noted)

SYMBOL	PARAMETERS	CONDITIONS	LIMITS			UNIT
			MIN.	TYP.	MAX.	
VREF	VREF output voltage	VREF=0A	2.0	2.5	3.0	V
VLIMIT	LIMIT output voltage	LIMIT=0A	2.7	3.4	4.1	V
VLIMIT2	LIMIT output voltage	VCC-RS voltage when VREF=LIMIT=OPEN	405	450	495	mV
VLIMIT3	LIMIT output voltage	VCC-RS voltage when VREF=OPEN, LIMIT=5V	540	600	660	mV
ILIMIT2	LIMIT output current	VREF=OPEN, LIMIT=OPEN VCC-RS =0.5Ω	810	900	980	mA
ILIMIT3	LIMIT output current	VREF=OPEN, LIMIT=5V VCC-RS =0.5Ω	1.08	1.20	1.32	A
VFGL	FGout output voltage at "Lo" function	Load current I=5mA	—	—	0.6	V
VGREF	FG Amp &Comp. reference voltage	Voltage on the Amp.out pin when shorted to the FG+ pin.	2.35	2.50	2.65	V
FGIN	FG +voltage input range	Voltage on the Amp.out pin when shorted to the FG+ pin.	1.0	—	5.5	V
AV	FG Amp. voltage gain	External resistors: 1.8 kΩ, 56 kΩ	29.5	31.1	32.7	times
AV20K	FG Amp. voltage gain at 20kHz	No load on Amp.out. Voltage gain of the signal on Amp.out pin for an input 50-mVpp, 20-kHz AC signal on FG+. External resistors: 1.8 kΩ, 56 kΩ	22	27.6	32.7	times
VAmpout	Ampout voltage output range		1.0	—	5.2	V
IAmpout	Ampout sink current	Aout<=1.0V	4.0	—	—	mA
IFGout	FGout sink current	FGout<=1.0V	4.0	—	—	mA
HisH	FG Comp. high-side hysteresis voltage	Given a rising external voltage on Amp.out and VthH as the voltage at which FGout switches from high to low, hysteresis voltage HysH is defined as VthH-FGref. Voltage on FGin is 1 V (external resistors: 1.8 kΩ, 56 kΩ).	10.5	28.5	50.5	mV
HisL	FG Comp. Lo-side hysteresis voltage	Given a falling external voltage on Ampout and VthL as the voltage at which FGout switches from high to low, hysteresis voltage HysL is defined as FGref-VthL. Voltage on FGin is 1 V (external resistors: 1.8 kΩ, 56 kΩ).	10.5	28.5	50.5	mV
FGduty	FGComp. Duty 30kHz	Duty cycle of signal on FGout when a 50-mVpp, 30-kHz AC signal is input to FGin. External resistors: 1.8 kΩ, 56 kΩ.	40	50	60	%

Electrical Characteristics

(Ta=25°C, Vcc=24V unless otherwise noted)

SYMBOL	PARAMETERS	REMARK	LIMITS			UNIT
			MIN.	TYP.	MAX.	
Toff	OFF Timer	OSCR=12.5kΩ, OSCC=1000pF	10	18	25	μsec

Confirmend Parameters At Es Evaluation

SYMBOL	PARAMETERS	REMARK	LIMITS			UNIT
			MIN.	TYP.	MAX.	
TSD	Protection temperature		145	160	175	°C
ΔT	Temperature hysteresis		15	30	45	°C

This devise does not guarantee the electrical function above TSD function temperature range.

The function is guaranteed under maximum junction temperature that is regulated in the

Absolute Maximum Rating, so TSD function is a protection circuit for unusual Tj when this devise is used over Tj 150°C.

Therefore, this devise must function under Tj maximum 150°C condition.

Application Circuit (1)

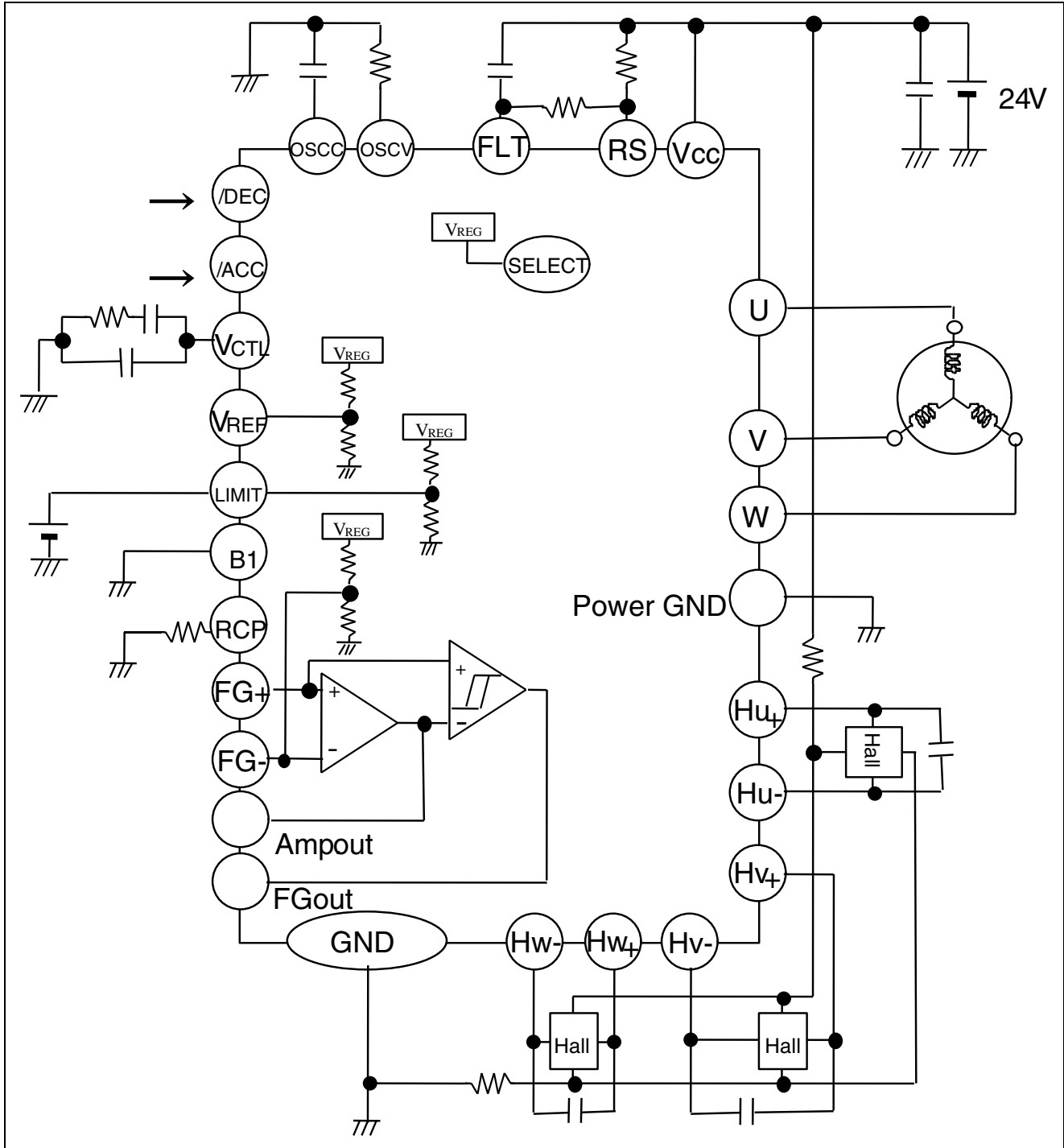

Application Circuit (2)

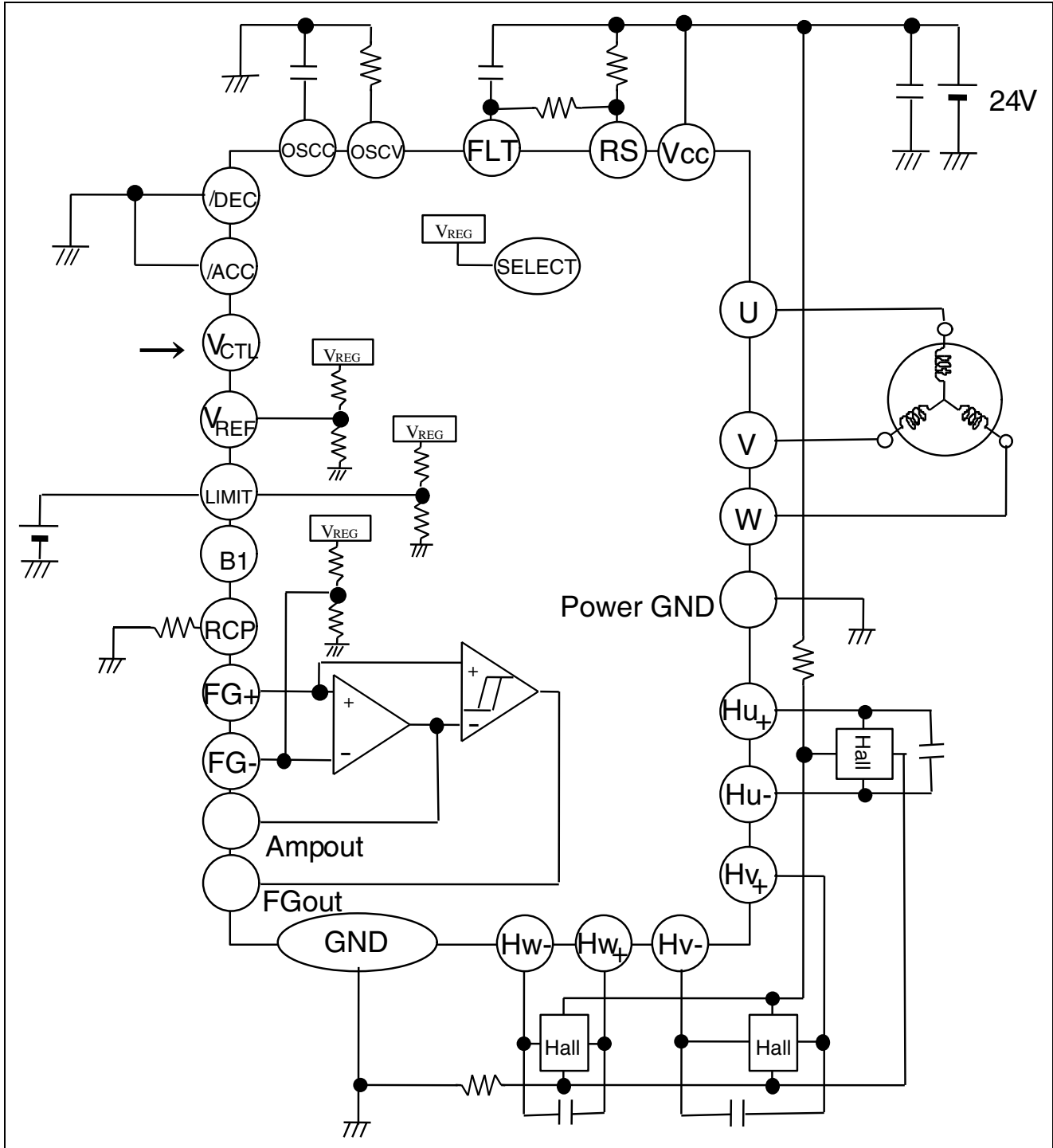

PWM Function Description

Chopping PWM control is applied to supply driving current to the motor in proportion to the analog-voltage input.

This IC detects the flow of current to the motor and the power supply continues to supply current until it reaches a level specified in terms of the input voltage (current path 1). At that time, the output transistors are switched, and energy stored in the coil regenerates current for a period determined by the internal off-timer circuit (current path 2). When the timer reaches the specified value, the power supply again starts to supply current. Operation proceeds through repetition of these phases.

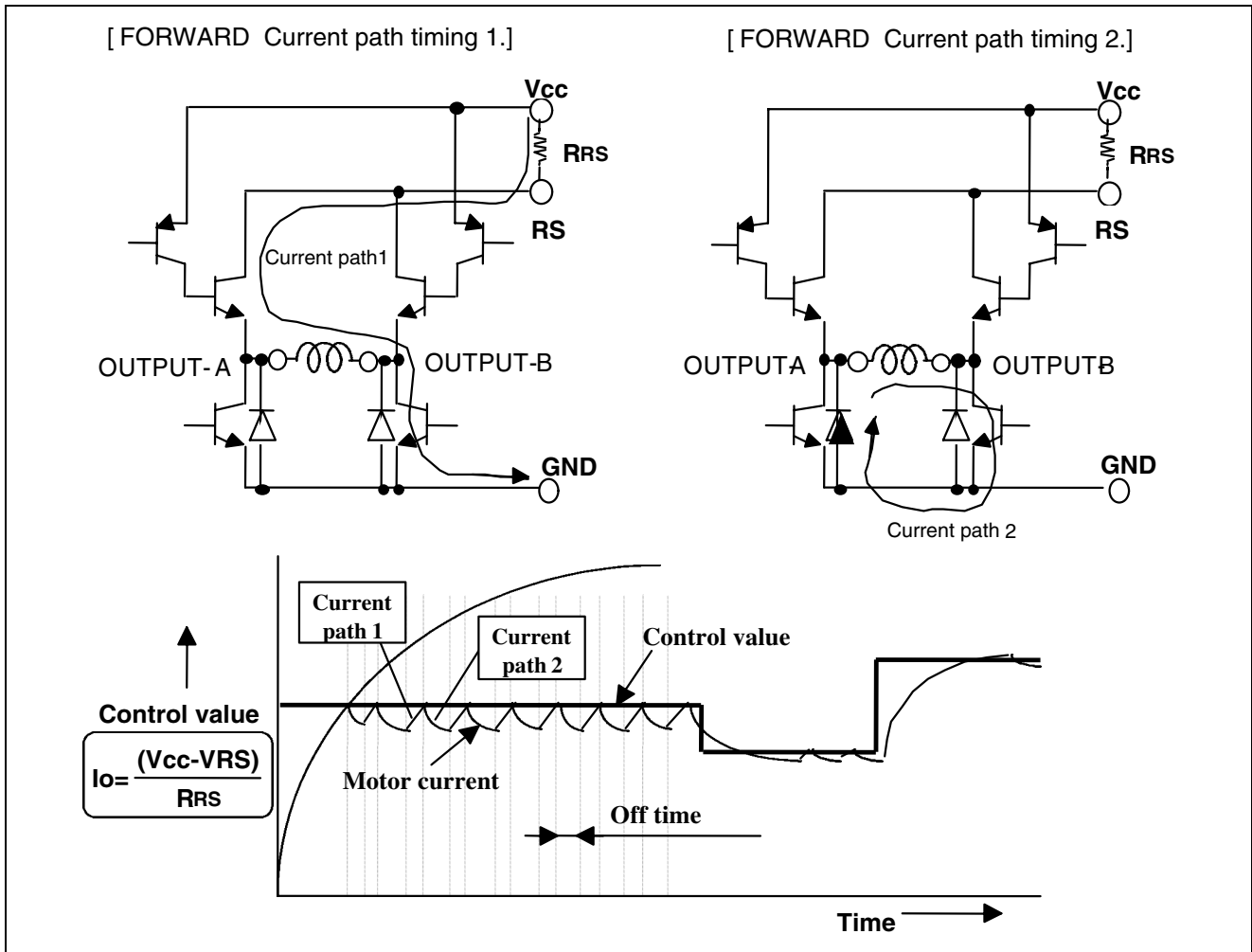

VCTL vs Io Characteristics-1

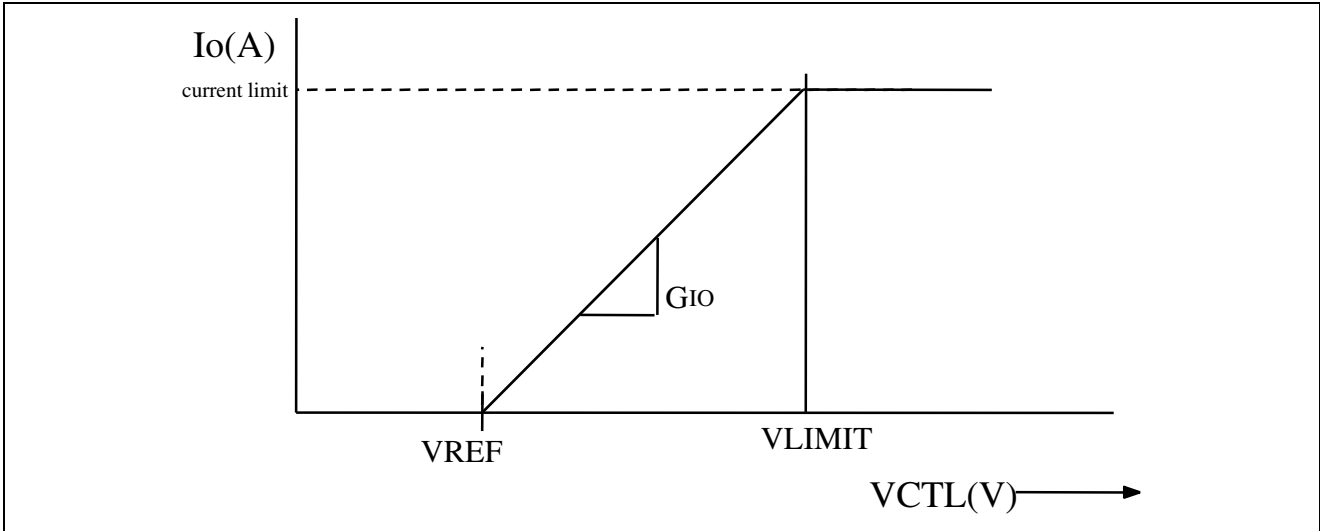

Drive Mode Function

B1	Function
H	Reverse (right turn)
L or open	Forward (left turn) / short brake

Note: When the B1 pin of the M63154AFP is set low or left open-circuit, short braking operation is applied to the M63154AFP when the motor is turned off. When the B1 pin is fixed high (5 V), this operation is not applied. For directions of rotation in the table at left, see the timing chart on page 12.

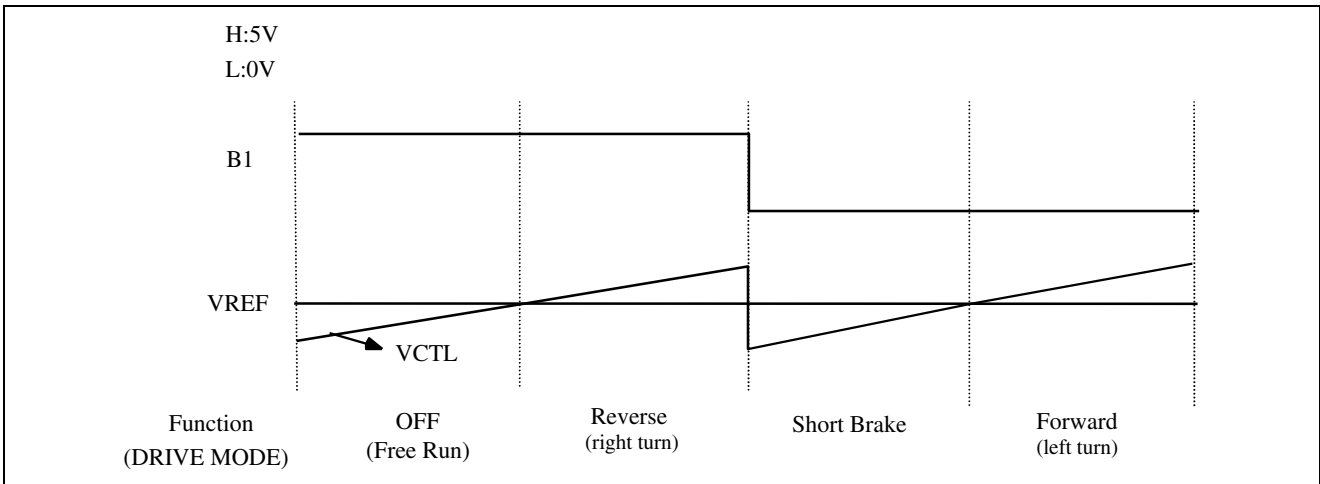

CHARGE PUMP FUNCTION

ACC	DEC	VCTL(CPout) output current	Function
H(5V)	H(5V)	0 μ A	Hold
H(5V)	L(0V)	-200 μ A	Deceleration
L(0V)	H(5V)	+200 μ A	Acceleration
L(0V)	L(0V)	0 μ A	Hold

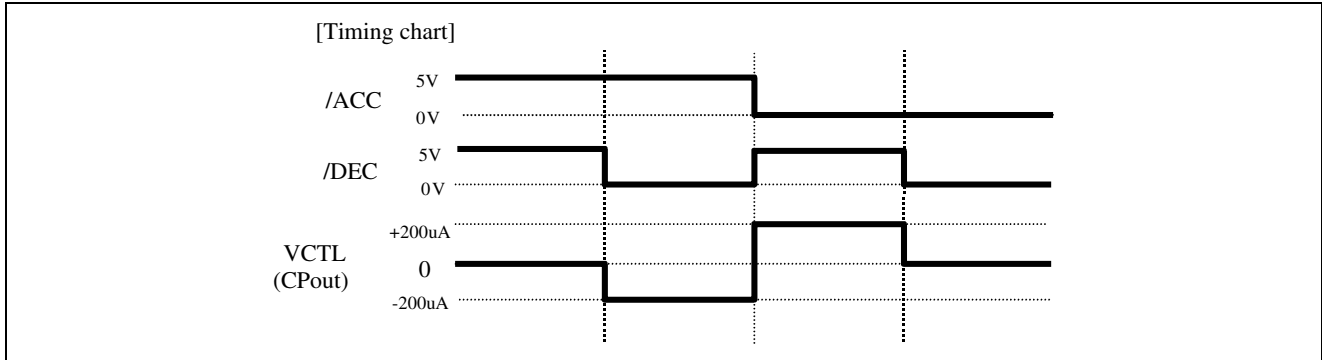

OSCC Connecta Output Voltage Function

The OFF time of the current-chopper is determined by the capacitance connected to the OSCC pin and the resistance connected to the OSCR pin. The calculation is as follows:

$$T_{off} = 0.9 [V] \times C [F] / (1.25 [V] / 2R [k\Omega])$$

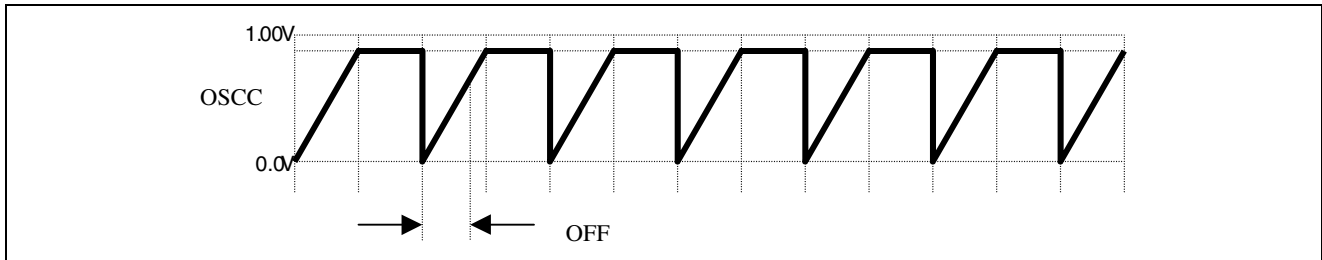

Timing charts of motor output current and hall input voltage

Note: In the plots of Hall-sensor input, the bold curves are for (+).

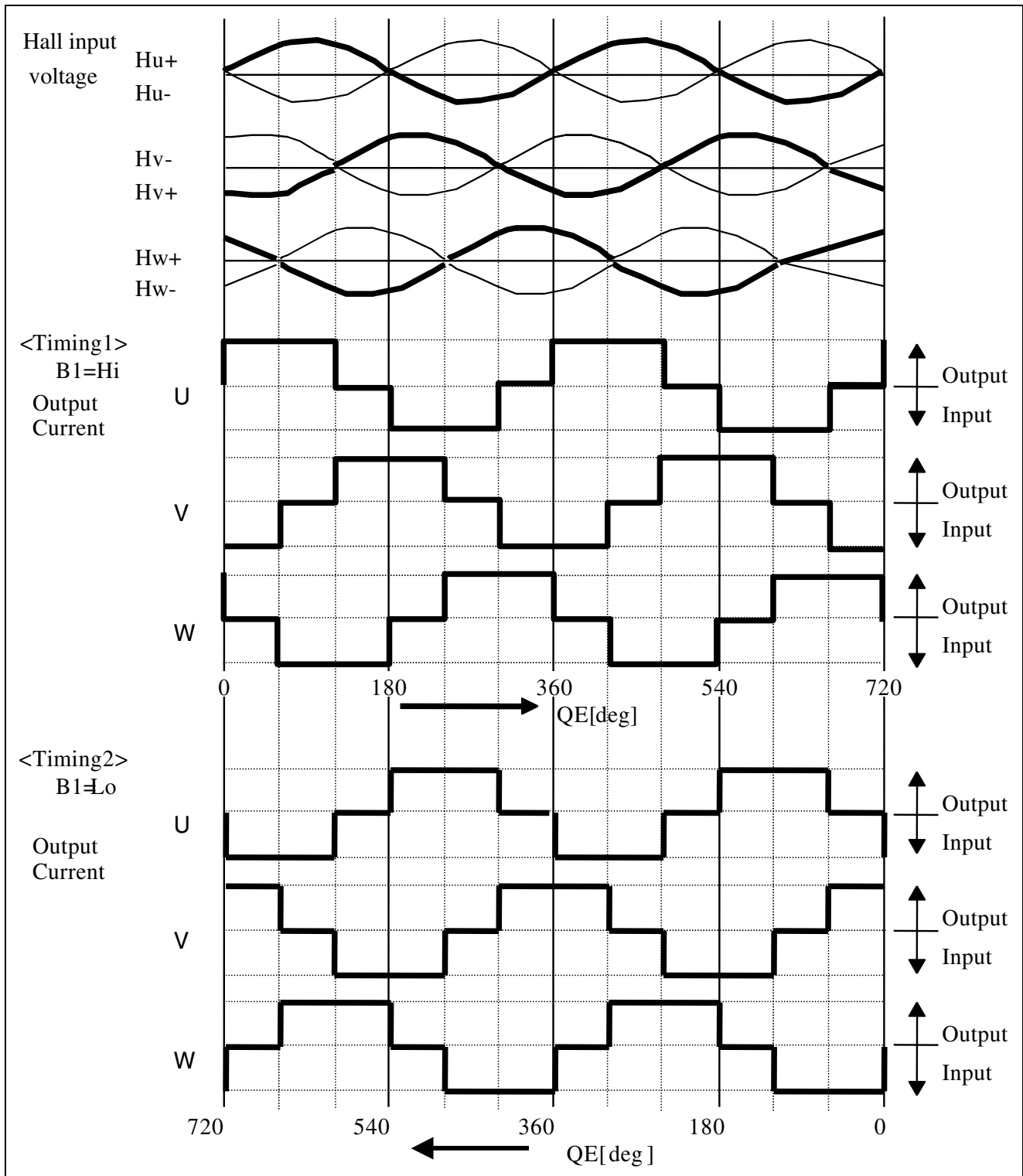

Note: The waveforms given above merely demonstrate the timing and are not the same as the waveforms for the motor in operation.

Timing Chart of Voltages on Individual Pins in PWM Control

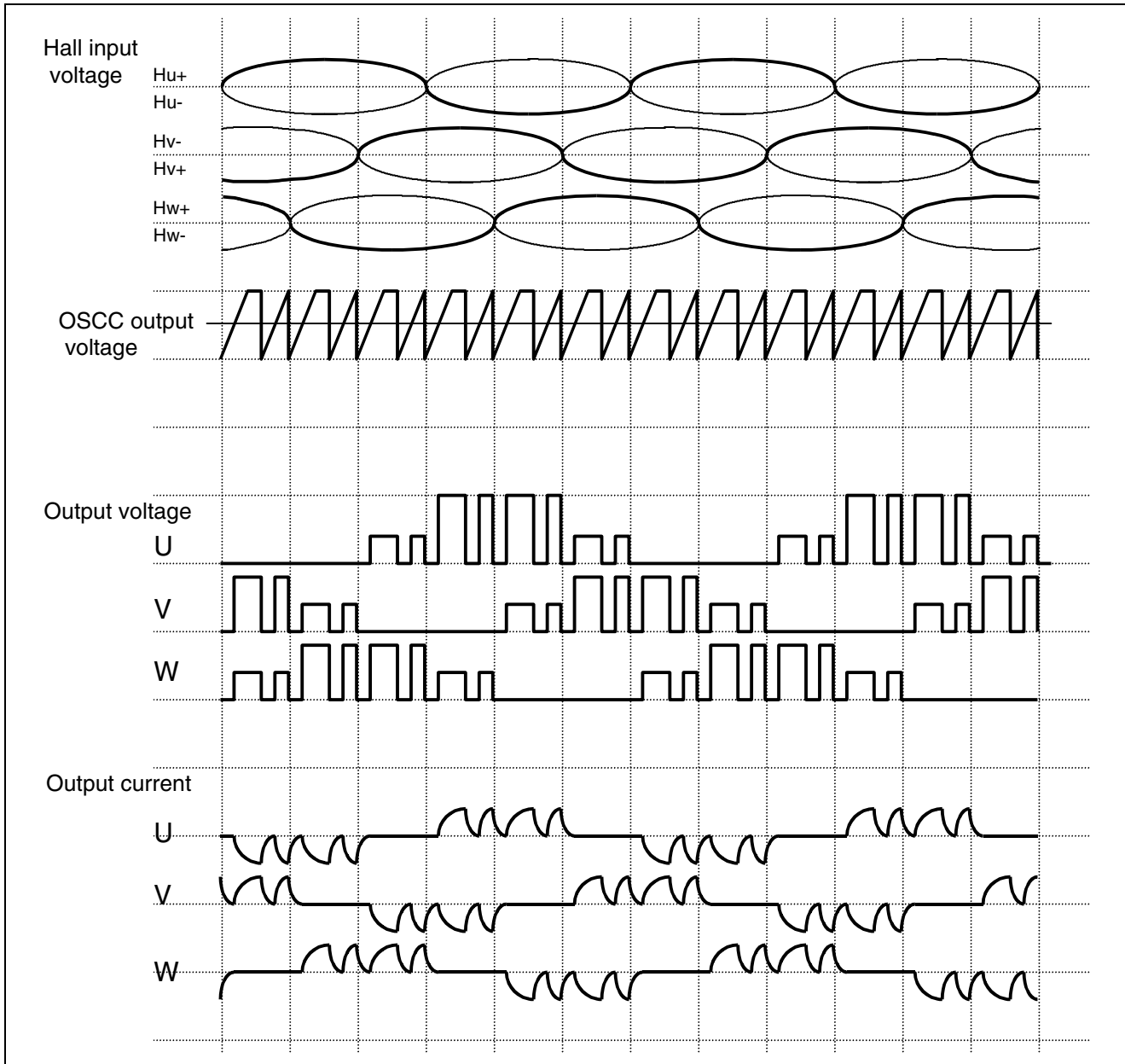

The current from the RS pin is detected at the FLT pin. This current reaching a value specified by the voltage on the VCTL pin indicates full discharge. After charging, the voltage on the OSCC pin (pin 23) sets the off-period for PWM current-chopping control.

Whenever a Hall input switches polarity, the voltage on the OSCC pin is temporarily reset to 0 V. While the voltage on the OSCC pin is 0.9 V or less, the PWM waveforms are off (regenerative operation). Otherwise, PWM waveforms are on.

The above timing chart shows the timing with which outputs for the motor are switched on and off during PWM control. Timing for the switching of outputs in response to Hall input varies with the setting of the B1 pin.

Package Dimensions

36P2R-D

(MMP)

Plastic 36pin 450mil SSOP

EIAJ Package Code	JEDEC Code	Weight(g)	Lead Material
SSOP36-P-450-0.80	—	0.53	Cu Alloy

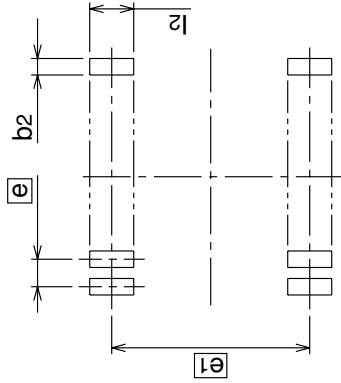
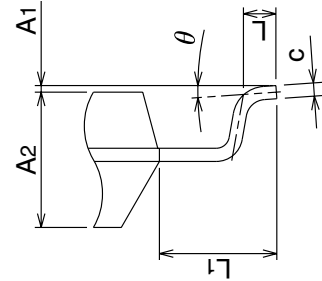
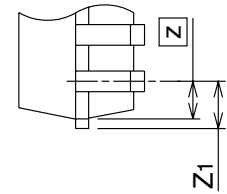
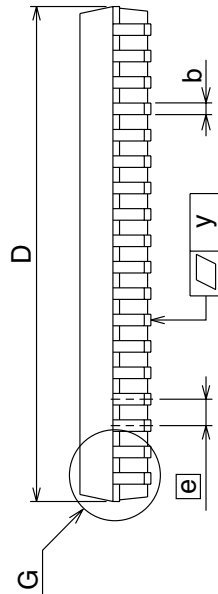
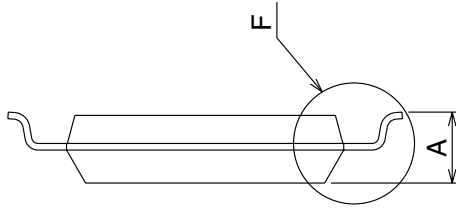
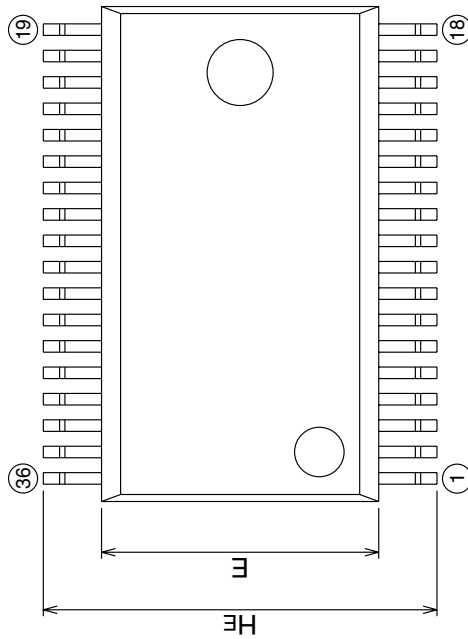

Recommended Mount Pad

Symbol	Dimension in Millimeters		
	Min	Nom	Max
A	—	—	2.35
A1	0	0.1	0.2
A2	—	2.05	—
b	0.3	0.35	0.45
c	0.18	0.2	0.25
D	14.8	15.0	15.2
E	8.2	8.4	8.6
e	—	0.8	—
HE	11.63	11.93	12.23
L	0.3	0.5	0.7
L1	—	1.765	—
Z	—	0.7	—
Z1	—	—	0.85
y	—	—	0.15
theta	0°	—	8°
b2	—	0.5	—
e1	—	11.43	—
l2	1.27	—	—

RENESAS Technology Corp. Sales Strategic Planning Div. Nippon Bldg., 2-6-2, Ohte-machi, Chiyoda-ku, Tokyo 100-0004, Japan

Keep safety first in your circuit designs!

1. Renesas Technology Corp. puts the maximum effort into making semiconductor products better and more reliable, but there is always the possibility that trouble may occur with them. Trouble with semiconductors may lead to personal injury, fire or property damage.
Remember to give due consideration to safety when making your circuit designs, with appropriate measures such as (i) placement of substitutive, auxiliary circuits, (ii) use of nonflammable material or (iii) prevention against any malfunction or mishap.

Notes regarding these materials

1. These materials are intended as a reference to assist our customers in the selection of the Renesas Technology Corp. product best suited to the customer's application; they do not convey any license under any intellectual property rights, or any other rights, belonging to Renesas Technology Corp. or a third party.
 2. Renesas Technology Corp. assumes no responsibility for any damage, or infringement of any third-party's rights, originating in the use of any product data, diagrams, charts, programs, algorithms, or circuit application examples contained in these materials.
 3. All information contained in these materials, including product data, diagrams, charts, programs and algorithms represents information on products at the time of publication of these materials, and are subject to change by Renesas Technology Corp. without notice due to product improvements or other reasons. It is therefore recommended that customers contact Renesas Technology Corp. or an authorized Renesas Technology Corp. product distributor for the latest product information before purchasing a product listed herein.
The information described here may contain technical inaccuracies or typographical errors.
Renesas Technology Corp. assumes no responsibility for any damage, liability, or other loss rising from these inaccuracies or errors.
Please also pay attention to information published by Renesas Technology Corp. by various means, including the Renesas Technology Corp. Semiconductor home page (<http://www.renesas.com>).
 4. When using any or all of the information contained in these materials, including product data, diagrams, charts, programs, and algorithms, please be sure to evaluate all information as a total system before making a final decision on the applicability of the information and products. Renesas Technology Corp. assumes no responsibility for any damage, liability or other loss resulting from the information contained herein.
 5. Renesas Technology Corp. semiconductors are not designed or manufactured for use in a device or system that is used under circumstances in which human life is potentially at stake. Please contact Renesas Technology Corp. or an authorized Renesas Technology Corp. product distributor when considering the use of a product contained herein for any specific purposes, such as apparatus or systems for transportation, vehicular, medical, aerospace, nuclear, or undersea repeater use.
 6. The prior written approval of Renesas Technology Corp. is necessary to reprint or reproduce in whole or in part these materials.
 7. If these products or technologies are subject to the Japanese export control restrictions, they must be exported under a license from the Japanese government and cannot be imported into a country other than the approved destination.
Any diversion or reexport contrary to the export control laws and regulations of Japan and/or the country of destination is prohibited.
 8. Please contact Renesas Technology Corp. for further details on these materials or the products contained therein.
-



RENESAS SALES OFFICES

<http://www.renesas.com>

Renesas Technology America, Inc.
450 Holger Way, San Jose, CA 95134-1368, U.S.A
Tel: <1> (408) 382-7500 Fax: <1> (408) 382-7501

Renesas Technology Europe Limited.
Dukes Meadow, Millboard Road, Bourne End, Buckinghamshire, SL8 5FH, United Kingdom
Tel: <44> (1628) 585 100, Fax: <44> (1628) 585 900

Renesas Technology Europe GmbH
Dornacher Str. 3, D-85622 Feldkirchen, Germany
Tel: <49> (89) 380 70 0, Fax: <49> (89) 929 30 11

Renesas Technology Hong Kong Ltd.
7/F., North Tower, World Finance Centre, Harbour City, Canton Road, Hong Kong
Tel: <852> 2265-6688, Fax: <852> 2375-6836

Renesas Technology Taiwan Co., Ltd.
FL 10, #99, Fu-Hsing N. Rd., Taipei, Taiwan
Tel: <886> (2) 2715-2888, Fax: <886> (2) 2713-2999

Renesas Technology (Shanghai) Co., Ltd.
26/F., Ruijin Building, No.205 Maoming Road (S), Shanghai 200020, China
Tel: <86> (21) 6472-1001, Fax: <86> (21) 6415-2952

Renesas Technology Singapore Pte. Ltd.
1, Harbour Front Avenue, #06-10, Keppel Bay Tower, Singapore 098632
Tel: <65> 6213-0200, Fax: <65> 6278-8001